

2SP0320T

Preliminary Description & Application Manual

Driver solution for IGBT modules from Danfoss, Fuji and Infineon with an electrical interface for 2-level, 3-level and multilevel converter topologies with paralleling capability

Abstract

The 2SP0320T is a dual-channel driver with an electrical interface. The driver is based on CONCEPT's SCALE™-2 chipset, a highly integrated technology for the reliable driving and safe operation of IGBTs.

Perfectly matched driver versions are available for all corresponding IGBT modules from Danfoss, Fuji and Infineon. The plug-and-play capability of the driver allows immediate operation after mounting. The user needs invest no effort in designing or adjusting it to a specific application.

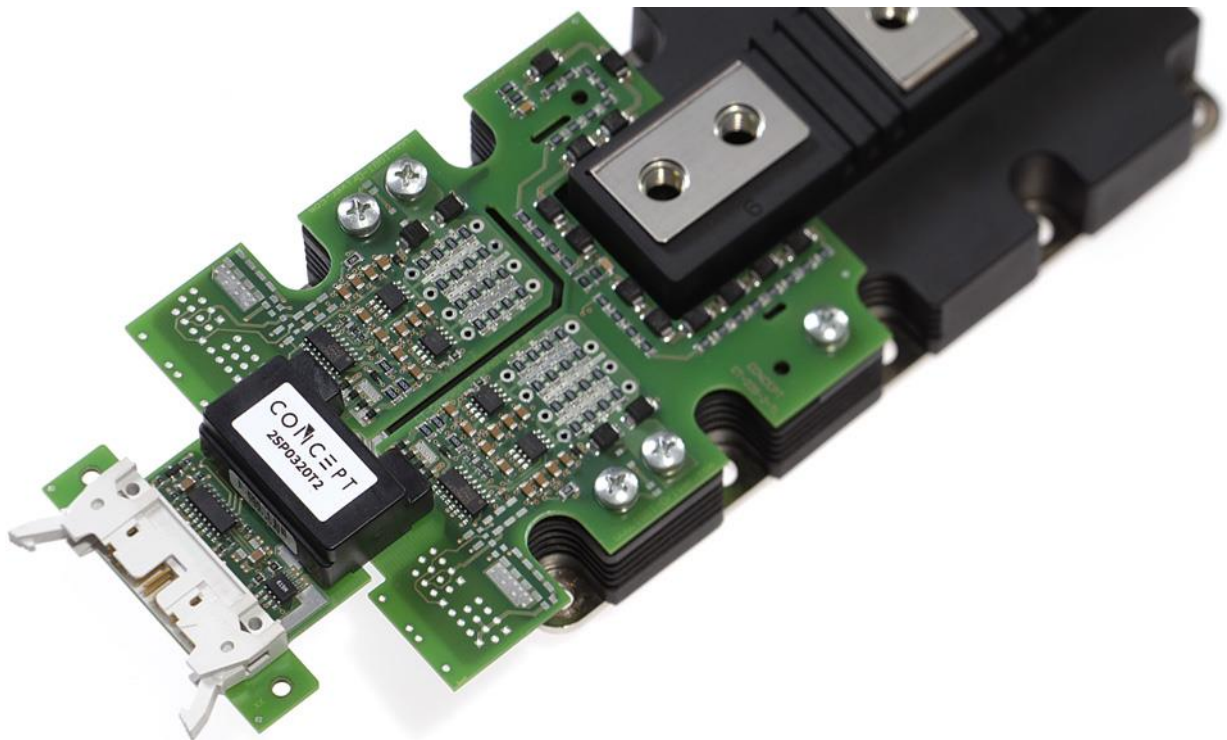

Fig. 1 2SP0320T screwed onto an IGBT module

Preliminary Description and Application Manual

Contents

System Overview	4
The Six Steps to Success.....	5
1. Choose a suitable driver	5
2. Attach the drivers to the IGBT modules.....	5
3. Connect the driver to the control electronics.....	5
4. Select the operating mode.....	5
5. Check the driver function.....	5
6. Set up and test the power stack	5
Mechanical Dimensions.....	6
Pin Designation of Connector X1	8
Recommended Interface Circuitry for Connector X1.....	8
Description of Interface X1.....	10
General	10
VCC terminal	10
VDC terminal	10
MOD (mode selection)	10
INA, INB (channel drive inputs, e.g. PWM)	11
SO1, SO2 (status outputs).....	11
TB (input for adjusting the blocking time)	12
How Do 2SP0320T SCALE-2 Drivers Work in Detail?.....	12
Overview.....	12
Power supply and electrical isolation	13
Power-supply monitoring.....	13
V _{CE} monitoring / short-circuit protection	14
Dynamic behavior of IGBTs	15
Turn-on of the IGBT / commutation of diode current	15
Turn-off of the IGBT	15
Advanced Active Clamping.....	15
Parallel connection of 2SP0320T	17
3-level and multilevel topologies	18
dV/dt feedback	18
Low-inductance layout	18
Higher requirements for traction applications or similar	19
Bibliography	19
The Information Source: SCALE-2 Driver Data Sheets	20

Preliminary Description and Application Manual

Quite Special: Customized SCALE-2 Drivers 20

Technical Support 20

Quality..... 20

Legal Disclaimer 20

Ordering Information..... 21

Information about Other Products 21

Manufacturer..... 21

Preliminary Description and Application Manual

System Overview

The 2SP0320T are plug-and-play drivers based on the highly integrated SCALE-2 chipset developed by CONCEPT /1/. This is a set of application-specific integrated circuits (ASICs) that cover the main range of functions needed to design intelligent gate drivers. The SCALE-2 driver chipset is a further development of the proven SCALE technology /2/.

The basic topology of the 2SP0320T driver is shown in Fig. 2. The values for the gate resistors and other key components can be found in the specific datasheets for a given IGBT module /3/.

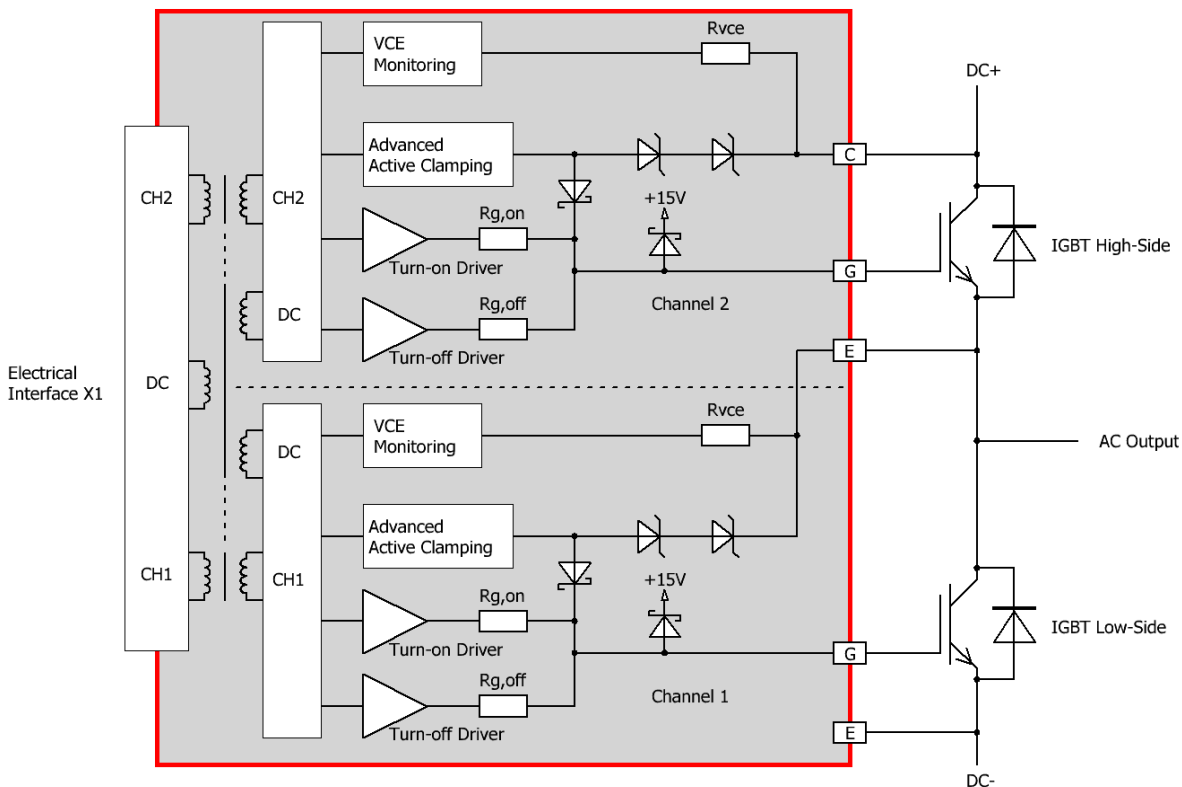

Fig. 2 Basic schematic of the 2SP0320T driver

The driver contains all necessary components for optimal and safe driving of the relevant IGBT module: smallest gate resistors in order to minimize switching losses, gate clamping, active-clamping diodes (overvoltage protection at turn-off), V_{CE} monitoring (short-circuit protection) as well as the input electrical connector X1. Moreover, it includes components for setting the turn-off trip level, the response time and the dead time between both channels in half-bridge mode. Its plug-and-play capability means that it is ready to operate immediately after mounting. The user needs invest no effort in designing or adjusting the driver to a specific application.

Preliminary Description and Application Manual

The Six Steps to Success

The following steps point out the easy way to use 2SP0320T drivers in power converters:

1. Choose a suitable driver

When applying 2SP0320T drivers, you should note that they are specifically adapted to a particular type of IGBT module.

The type designation of the driver consequently also includes a number corresponding to a specific IGBT module (see "Ordering Information").

These drivers are not valid for IGBT modules other than those specified. Incorrect use may result in failure.

2. Attach the drivers to the IGBT modules



Any handling of IGBT modules or drivers is subject to the general specifications for protecting electrostatic-sensitive devices according to international standard IEC 60747-1, Chapter IX or European standard EN 100015 (i.e. the workplace, tools, etc. must comply with these standards).

If these specifications are ignored, both IGBTs and drivers may be damaged.

The driver can be easily mounted onto an IGBT module by screwing the corresponding terminals.

3. Connect the driver to the control electronics

Connect the driver plug X1 to your control electronics and supply the driver with a voltage of 15V.

4. Select the operating mode

The operating mode can be set with input MOD (interface X1: pin 17). For details, see page 10).

5. Check the driver function

Check the gate voltage: For the off-state, the nominal gate voltage is specified in the relevant data sheet /3/. For the on-state, it is 15V. Also check the input current consumption of the driver without clock signals and at the desired switching frequency.

These tests should be performed before installation, as the gate terminals may otherwise not be accessible.

6. Set up and test the power stack

Before starting up the system, it is recommended that each IGBT module be checked separately under power-cycling conditions. It is usually sufficient to apply the single or double-pulse technique. CONCEPT specially

Preliminary Description and Application Manual

recommends users to check that the IGBT modules switch inside the SOA in the worst case condition, as this strongly depends on the specific converter construction.

Even if only single IGBTs are tested, all the system's gate drivers must be supplied with energy. All the other IGBTs are then kept in the off state by applying negative gate voltages. This is particularly important when switching the IGBTs under test.

The short-circuit behavior can also be verified at this point.

The system is then ready to start under real-world load conditions. This allows the thermal behavior of the whole arrangement to be determined.

The system must be re-qualified over the entire specified range of temperature and load conditions.



CAUTION: All handling with high voltages involves risk to life. It is imperative to comply with the respective safety regulations!

Mechanical Dimensions

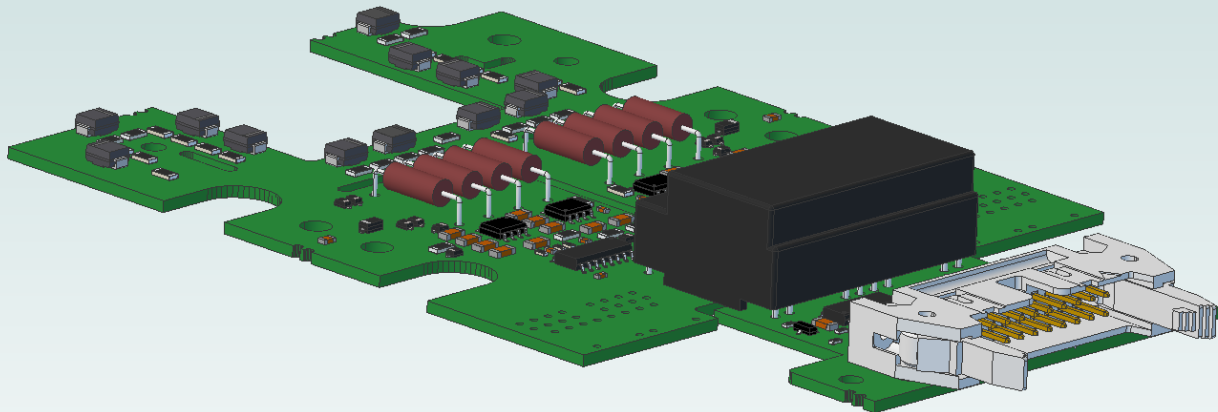
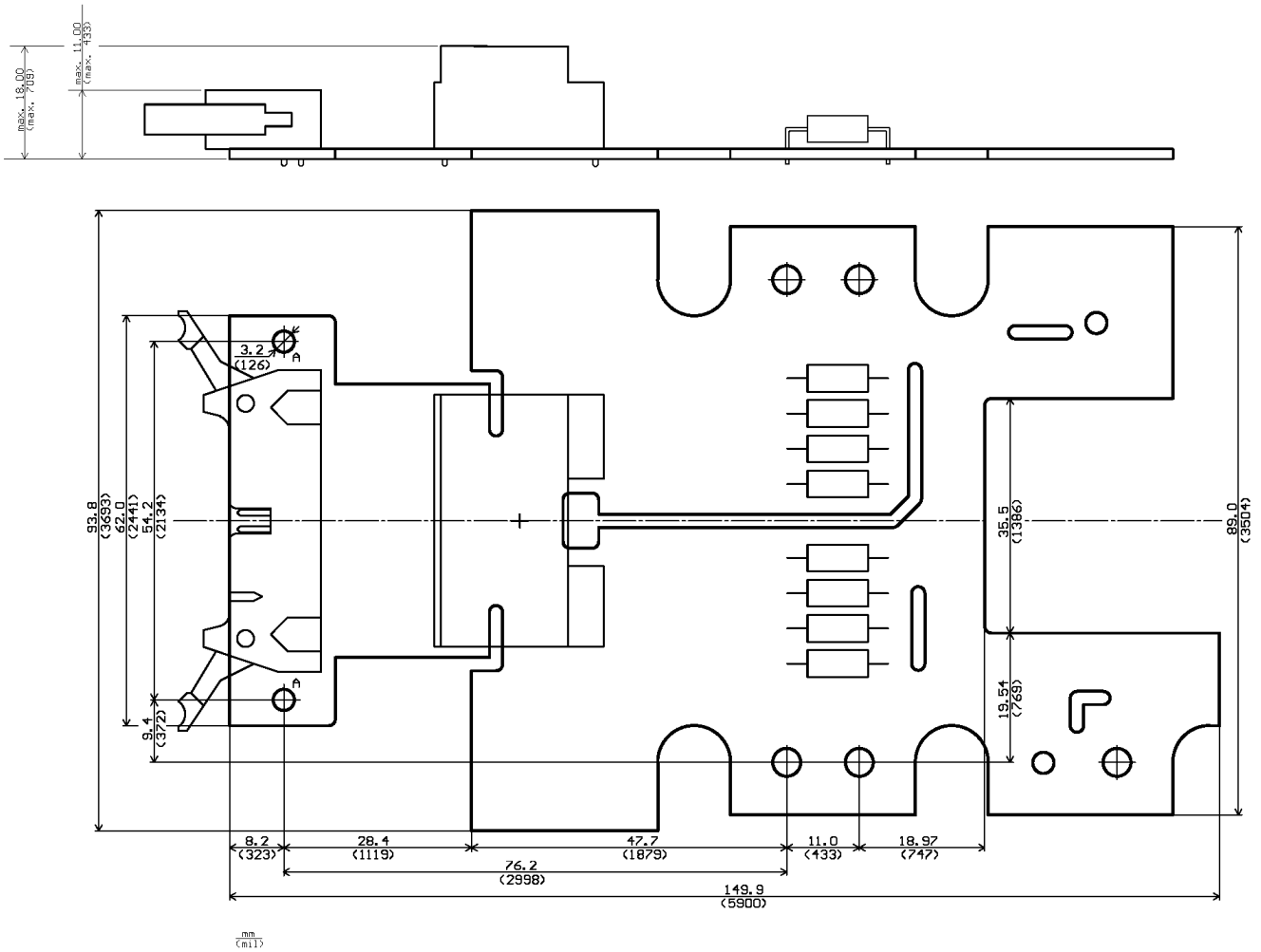

Fig. 3 Interactive 3D drawing of 2SP0320T

Preliminary Description and Application Manual



Holes A: fixing holes

Electrical connector on the driver: 71922-120LF from FCI, recom. cable connector: 71600-020LF from FCI

Recommended twisted pair flat cable: 1700/20 or 2100/20 from 3M™

Fig. 4 Mechanical dimensions of 2SP0320T

Preliminary Description and Application Manual

Pin Designation of Connector X1

Pin	Des.	Function	Pin	Des.	Function
1	VDC	15V for DC/DC converter	2	GND	Ground
3	VDC	15V for DC/DC converter	4	GND	Ground
5	VCC	15V for primary side electronics	6	GND	Ground
7	VCC	15V for primary side electronics	8	GND	Ground
9	SO2	Status output channel 2	10	GND	Ground
11	INB	Signal input B	12	GND	Ground
13	SO1	Status output channel 1	14	GND	Ground
15	INA	Signal input A	16	GND	Ground
17	MOD	Mode selection (direct/half-bridge)	18	GND	Ground
19	TB	Blocking time	20	GND	Ground

Recommended Interface Circuitry for Connector X1

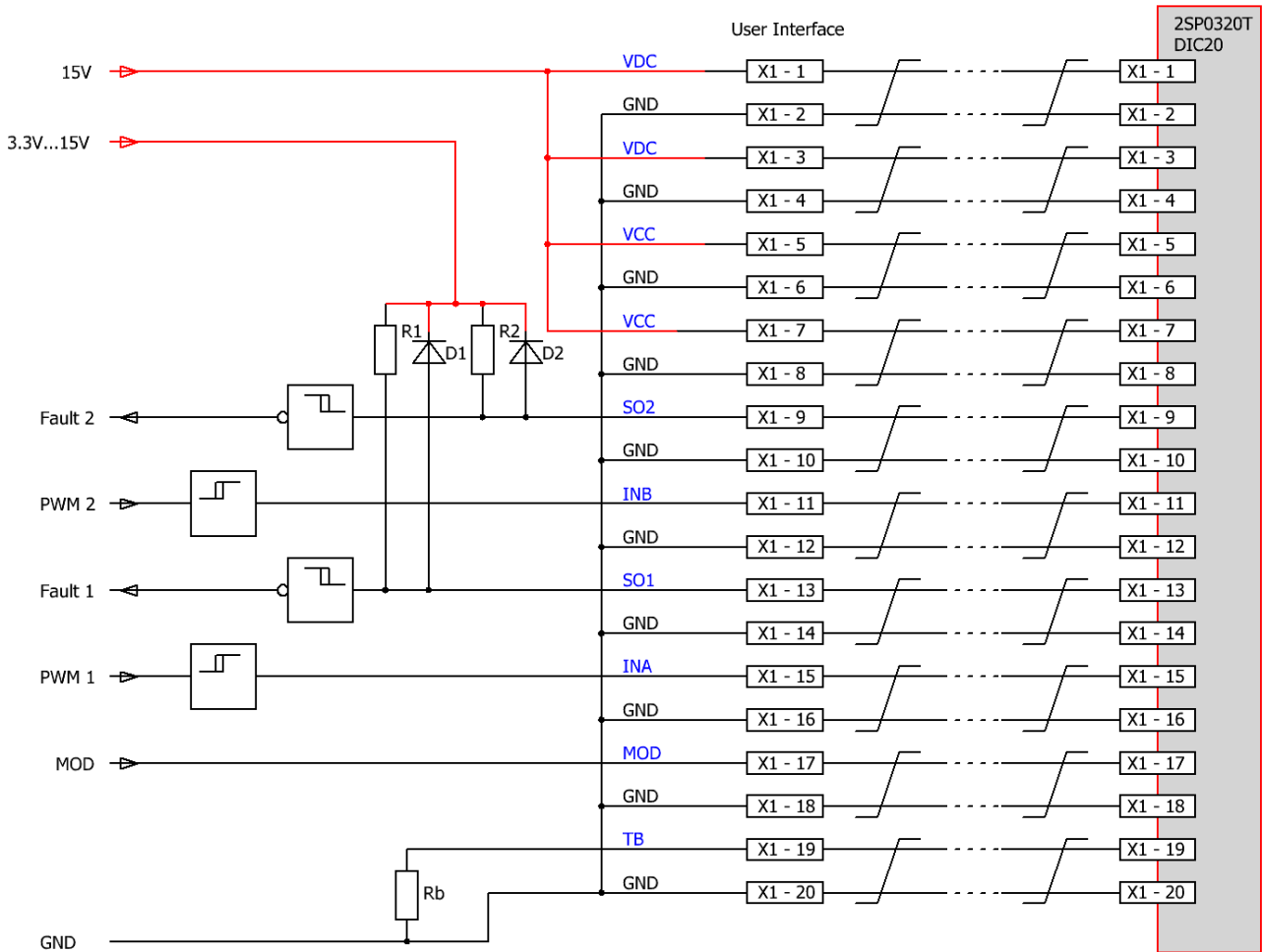

Fig. 5 Recommended user interface of 2SP0320T2Ax and 2SP0320T2Bx

Preliminary Description and Application Manual

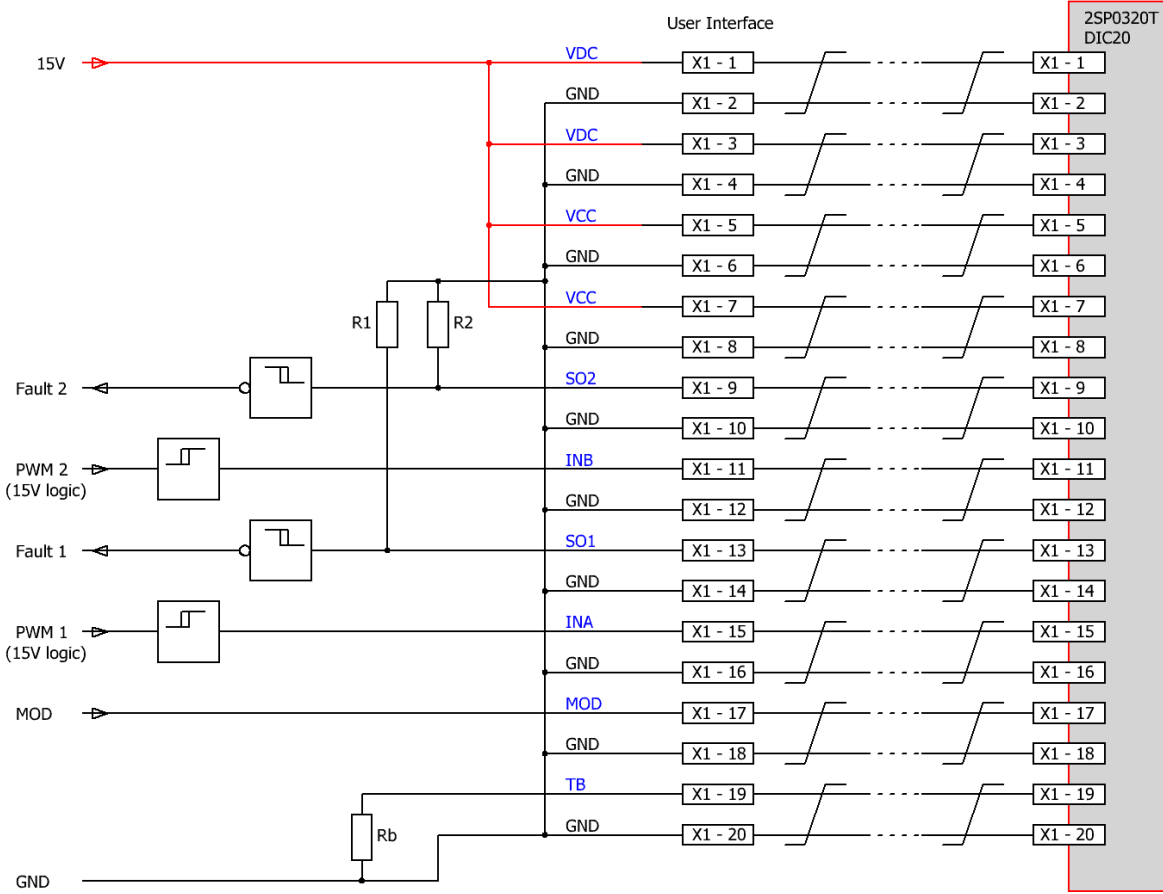

Fig. 6 Recommended user interface of 2SP0320T2Cx

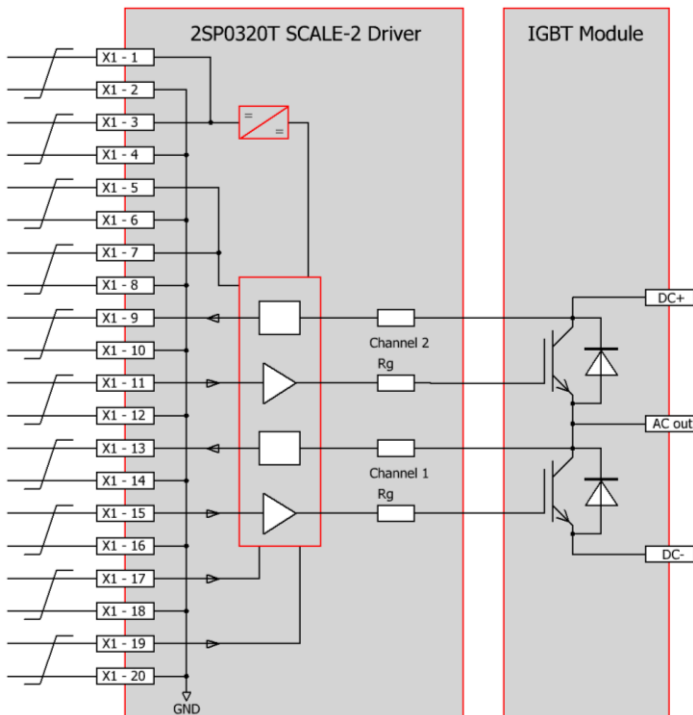

Fig. 7 Block diagram covering SCALE-2 driver 2SP0320T and IGBT module

Preliminary Description and Application Manual

Description of Interface X1

General

The interface X1 of the driver 2SP0320T is very simple and easy to use.

The driver has the following terminals:

- 4 x power-supply terminals (but only one 15V power supply is needed)
- 2 x drive signal inputs
- 2 x status outputs (fault returns)
- 1 x mode selection (half-bridge mode / direct mode)
- 1 x input to set the blocking time

The driver is equipped with a 20-pin interface connector. All even-numbered pins are used as GND connections. The odd-numbered pins are used as inputs or status outputs. It is recommended to use a 20-pin twisted flat cable. Each input and output signal is then twisted with its own GND wire. All GND pins are connected together on the 2SP0320T driver and should also be connected on the control-board side. This arrangement produces a very low-inductance connection with high immunity against interferences.

All inputs are ESD-protected. Moreover, all digital inputs have Schmitt-trigger characteristics.

VCC terminal

The driver has two VCC terminals on the interface connector to supply the primary side electronics.

VDC terminal

The driver has two VDC terminals on the interface connector to supply the DC-DC converters for the secondary sides.

As the driver can deliver a total power of $2 \times 3W = 6W$, the maximum input current drawn from the 15V supply is approx. 0.5A (total for VDC and VCC terminals).

All VCC and VDC terminals must be connected to a single 15V power supply. The driver limits the inrush current at startup, and no external current limitation of the voltage source for VDC is needed. VDC and VCC terminals are split into separate pins only for testing.

MOD (mode selection)

The MOD input allows the operating mode to be selected.

Direct mode

If the MOD input is not connected (floating), or connected to VCC, direct mode is selected. In this mode, there is no interdependence between the two channels. Input INA directly influences channel 1 while INB influences channel 2. High level at an input (INA or INB) always results in turn-on of the corresponding IGBT. This mode should be selected only when the dead times are generated by the control circuitry so that each IGBT receives its own drive signal.

Caution: Synchronous or overlapping timing of both switches of a half-bridge basically shorts the DC link.

Preliminary Description and Application Manual

Half-bridge mode

If the MOD input is low level (connected to GND), half-bridge mode is selected. In this mode, the inputs INA and INB have the following functions: INA is the drive signal input while INB acts as the enable input (see Fig. 8).

When input INB is low level, both channels are blocked. If it goes high, both channels are enabled and follow the signal on the input INA. At the transition of INA from low to high, Channel 2 turns off immediately and Channel 1 turns on after a dead time. The dead time is set by a resistor on the 2SP0320T.

Note that the dead time may vary from sample to sample. A tolerance of approximately $\pm 20\%$ may be expected. If higher timing precisions are required, CONCEPT recommends using direct mode and generating the dead time externally (refer to Application Note AN-1101 /7/).

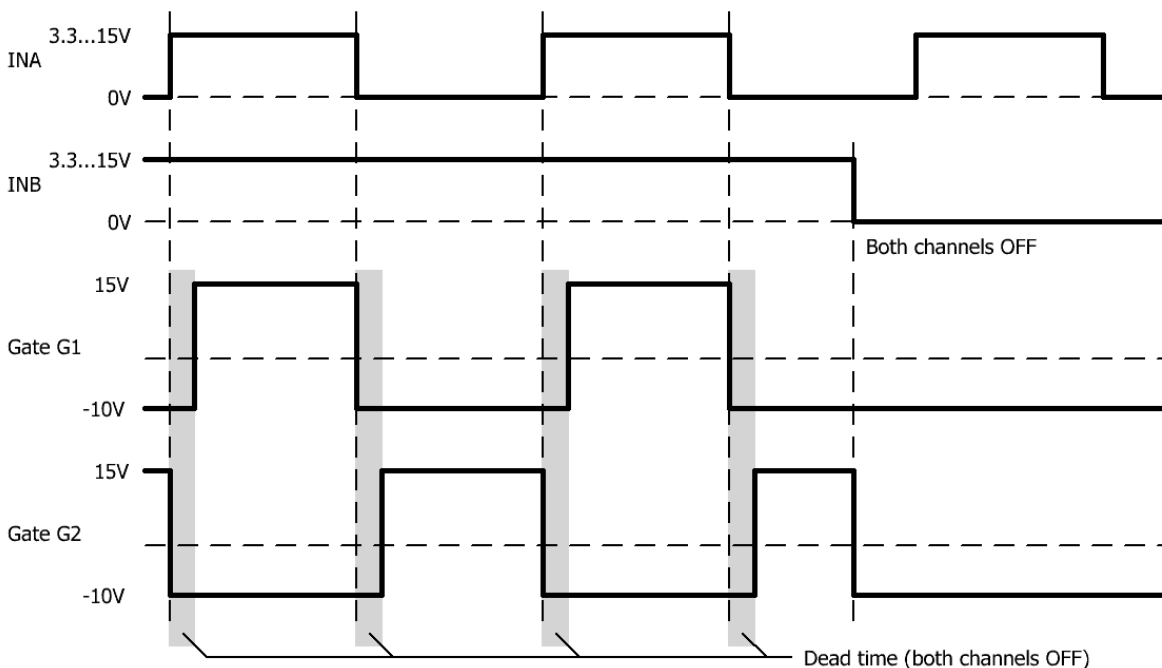

Fig. 8 Signals in half-bridge mode

INA, INB (channel drive inputs, e.g. PWM)

INA and INB are basically drive inputs, but their function depends on the MOD input (see above). 2SP0320T2Ax and 2SP0320T2Bx safely recognize signals in the whole logic-level range between 3.3V and 15V. They have built-in 4.7k Ω pull-down resistors. 2SP0320T2Cx safely recognize signals with a logic level of 15V. They have built-in voltage dividers with a total resistance of 4.5k Ω .

INA and INB feature Schmitt-trigger characteristics (see the specific datasheets for a given IGBT module /3/). An input transition is triggered at any edge of an incoming signal at INA or INB.

SO1, SO2 (status outputs)

The outputs SOx have open-drain transistors. They can be connected together to provide a common fault signal (e.g. for one phase). However, it is recommended to evaluate the status signals individually to allow fast and precise fault diagnosis.

Preliminary Description and Application Manual

The maximum SOx current in a fault condition should not exceed the value specified in the driver data sheets /3/.

2SP0320T2Ax/2SP0320T2Bx

When no fault condition is detected, the outputs have high impedance. An internal current source of 500µA pulls the SOx outputs to a voltage of about 4V when leaved open. When a fault condition is detected in channel "x", the status output SOx goes to low (connected to GND).

It is recommended to use the circuit shown in Fig. 5. The diodes D1 and D2 must be Schottky diodes and must only be used when using 3.3V logic. For 5V...15V logic, they can be omitted.

2SP0320T2Cx

When no fault condition is detected, an internal pull-up resistor of 10kΩ keeps the output voltage level at VCC. When a fault condition is detected, the corresponding status output SOx goes to low (connected to GND). It is recommended to use the circuit shown in Fig. 6. Both pull-down resistors R₁ and R₂ allow a missing SOx connection to be detected (safe logic in the event of a defective cable). Note that the resistors R₁ and R₂ must have a sufficiently high resistance value (e.g. 150kΩ), as they form a voltage divider together with the internal 10kΩ pull-up resistor on the driver.

How the status information is processed

- A fault on the secondary side (detection of short-circuit of IGBT module or supply undervoltage) is transmitted to the corresponding SOx output immediately. The corresponding SOx output is automatically reset after the blocking time Tb has elapsed (read the relevant data sheet for timing information /3/).
- A supply undervoltage on the primary side is indicated to both SOx outputs at the same time. Both SOx outputs are automatically reset when the undervoltage on the primary side disappears (read the relevant data sheet for timing information /3/).

TB (input for adjusting the blocking time)

The terminal TB allows the factory-set blocking time to be reduced by connecting an external resistor to GND (see Fig. 5 or Fig. 6). The following equation calculates the necessary resistor R_b connected between pins TB and GND in order to define the desired blocking time Tb (typical value):

$$R_b [k\Omega] = \frac{7650 + 150 \cdot Tb [ms]}{99 - Tb [ms]} - 6.8 \quad \text{where } 20ms < Tb < 90ms$$

The blocking time can also be set to a minimum of 9µs by selecting R_b=0Ω.

If not used, the input TB can be left open.

How Do 2SP0320T SCALE-2 Drivers Work in Detail?

Overview

The 2SP0320T series of plug-and-play dual-channel drivers are designed for corresponding IGBT modules from Danfoss, Fuji and Infineon. All drivers of the SCALE-2 driver family with an electrical interface are equipped with usual protection functions such as V_{CE} monitoring for short-circuit protection, operation inhibit after fault, supply-undervoltage shutdown and status feedback.

Preliminary Description and Application Manual

Outstanding features of 2SP0320T SCALE-2 drivers are: compact size, simple mounting - directly onto the IGBT module, Advanced Active Clamping function, very low propagation delay time, optional dV/dt feedback to reduce the high dV/dt at turn-off (refer to paragraph "dV/dt feedback" on page 17). Active clamping describes an active scheme designed to protect the IGBTs against overvoltage during turn-off. It is particularly relevant when turning an IGBT off in cases of high DC-link voltage and collector current or short circuit. The 2SP0320T series also allows parallel operation of IGBT modules in order to increase the system power (see "Parallel connection of 2SP0320T" on page 17).

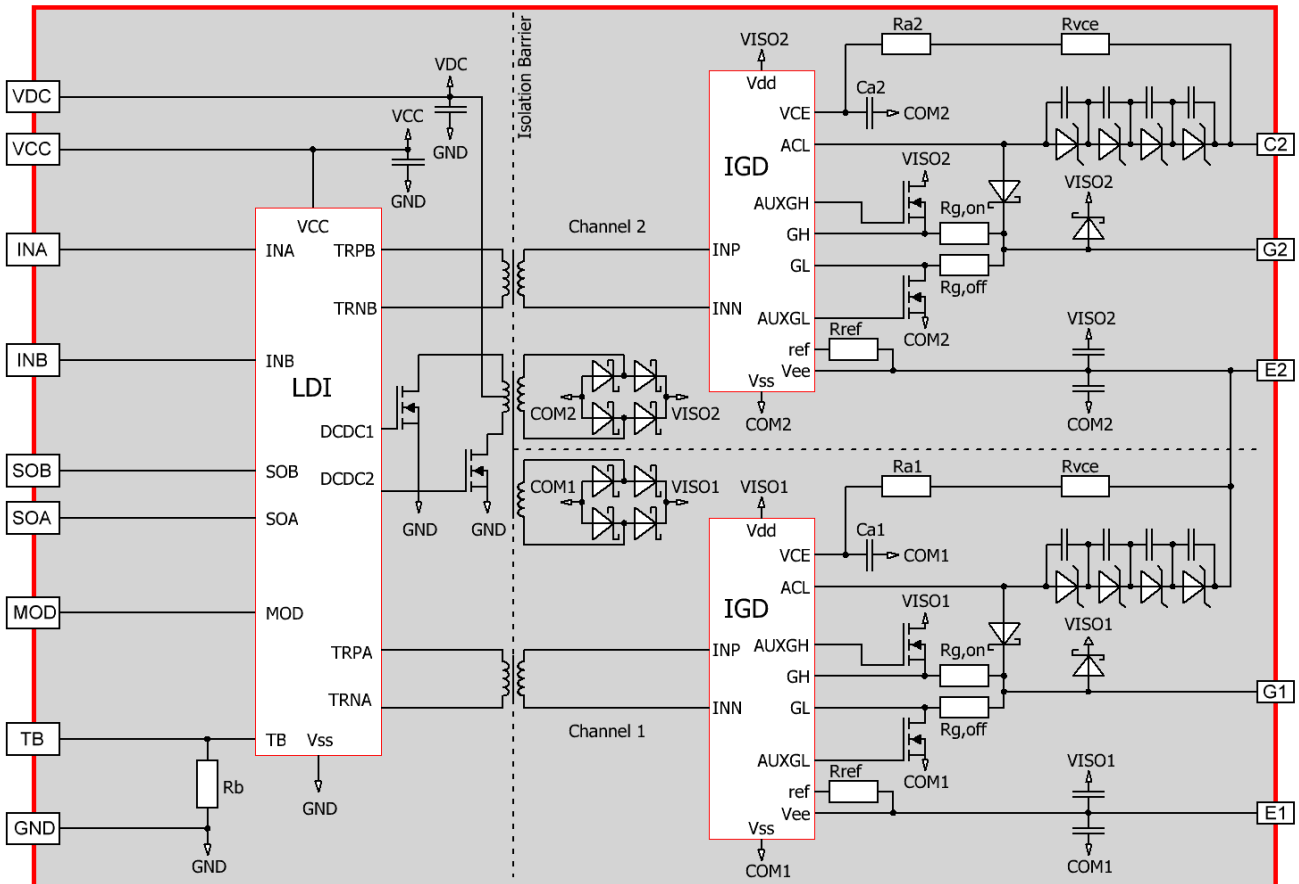

Fig. 9 Block diagram of the 2SP0320T SCALE-2 driver

Power supply and electrical isolation

The driver is equipped with a DC/DC converter to provide an electrically insulated power supply to the gate driver circuitry. The signal isolation is realized with transformers. All transformers (DC/DC and signal transformers) feature safe isolation to EN 50178, protection class II between primary side and either secondary side (refer to the data sheets /3/).

Note that the driver needs a stabilized supply voltage.

Power-supply monitoring

The driver's primary side as well as both secondary-side driver channels are equipped with a local undervoltage monitoring circuit.

Preliminary Description and Application Manual

In case of a primary-side supply undervoltage, both IGBTs are driven with a negative gate voltage to keep them in the off-state (both channels are blocked) and the fault is transmitted to both outputs SO1 and SO2 until the fault disappears.

In case of a secondary-side supply undervoltage, the corresponding IGBT is driven with a negative gate voltage to keep it in the off-state (the channel is blocked) and a fault condition is transmitted to the corresponding SOx output. The SOx output is automatically reset after the blocking time.

Even in the case of a low power supply voltage, the driver provides a low-impedance path from the IGBT gate to the emitter.

Within a half-bridge, it is advised not to operate the IGBTs with an IGBT driver in the event of a low supply voltage. Otherwise, a high rate of increase of V_{CE} may cause partial turn-on of these IGBTs.

V_{CE} monitoring / short-circuit protection

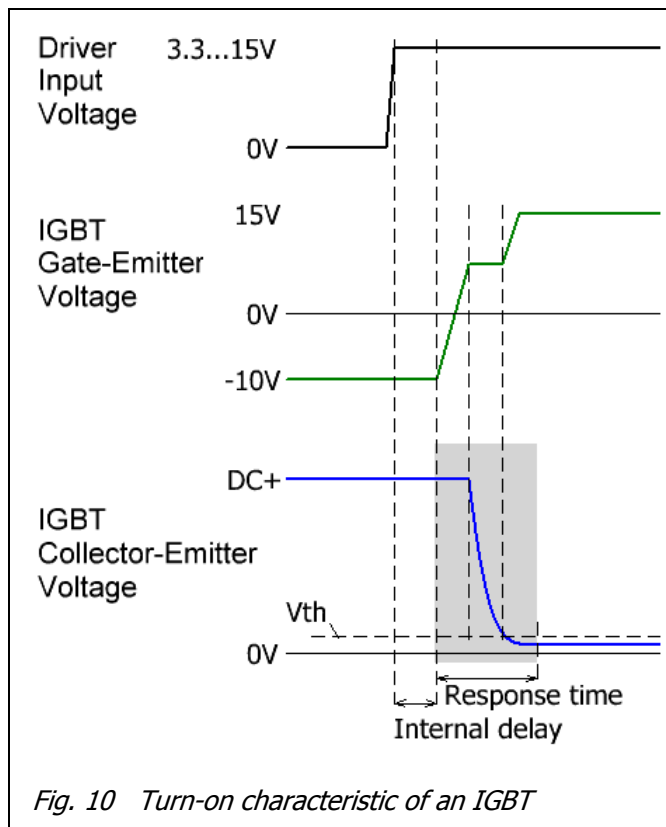

The basic V_{CE} monitoring circuit implemented in 2SP0320T SCALE-2 drivers is illustrated in Fig. 9. Both IGBT collector-emitter voltages are measured with a resistor network. V_{CE} is checked after the response time (see Fig. 10) at turn-on to detect a short circuit. If this voltage is higher than the programmed threshold V_{th} , the driver detects a short circuit at the IGBT and signals it immediately to the corresponding SOx output. After an additional delay, the corresponding IGBT is switched off. The IGBT is kept off (non-conducting) and the fault is shown at pin SOx as long as the blocking time is active.

The blocking time is applied independently to each channel. It starts when V_{CE} exceeds the threshold of the V_{CE} monitoring circuit.

It should be noted that the response time increases at DC-link voltages lower than about 550V. Please read the relevant driver data sheet for timing information [3].

Note: The desaturation function is for short-circuit detection only and cannot provide overcurrent protection. However, overcurrent detection has a lower time priority and can be easily provided by the application.

Preliminary Description and Application Manual

Dynamic behavior of IGBTs

The dynamic behavior of IGBT modules depends on the type and manufacturer due to the particular behavior of the included IGBT and diode chips, the particular module construction and the distribution of internal gate resistances and inductances. Note that different module types from the same manufacturer may also require a specific gate-driver adaptation.

CONCEPT therefore supplies specific versions of SCALE-2 plug-and-play drivers adapted to the particular IGBT module. **These drivers must not be used with IGBT modules other than those for which they were specified.**

Turn-on of the IGBT / commutation of diode current

When a driver input goes high, the gate driver turns on the corresponding IGBT. The driver already includes the gate resistors, which are matched to the relevant IGBT module.

The driver is optimized to achieve minimum switching losses for the case of relatively low inductances within the power stack. It is recommended to check the commutation behavior within the final system assembly.

Turn-off of the IGBT

The IGBT is turned off when the corresponding input turns low. The gate resistors are determined by CONCEPT and must not be altered.

Fast turn-off of the IGBT may cause overvoltage, which increases with DC-link voltage or load current. The turn-off overvoltage can be approximated by:

$$V_{tr} = -L_s * di/dt$$

where V_{tr} is the turn-off overvoltage and L_s the stray inductance.

Most competing drivers are unable to limit the overvoltage in case of overload or short circuit. However, this is essential for high-power or high-voltage IGBTs. To solve this problem, SCALE-2 plug-and-play drivers provide an Advanced Active Clamping function.

Moreover, 2SP0320T drivers feature an optional dV/dt feedback that reduces the high dV/dt at turn-off. Both active clamping and dV/dt feedback are described below.

Advanced Active Clamping

Active clamping is a technique designed to partially turn on the IGBT in case the collector-emitter voltage exceeds a predefined threshold. The IGBT is then kept in linear operation. The basic circuit for active clamping can be found in /4/.

Basic active-clamping topologies implement a single feedback path from the IGBT's collector through transient voltage suppressor devices (TVS) to the IGBT gate. The 2SP0320T SCALE-2 drivers support CONCEPT's Advanced Active Clamping based on this principle: when active clamping is activated, the turn-off MOSFET of the driver is switched off in order to improve the effectiveness of the active clamping and to reduce the losses in the TVS. This feature is mainly integrated in the secondary-side ASIC. The circuitry used is shown in Fig. 9.

Preliminary Description and Application Manual

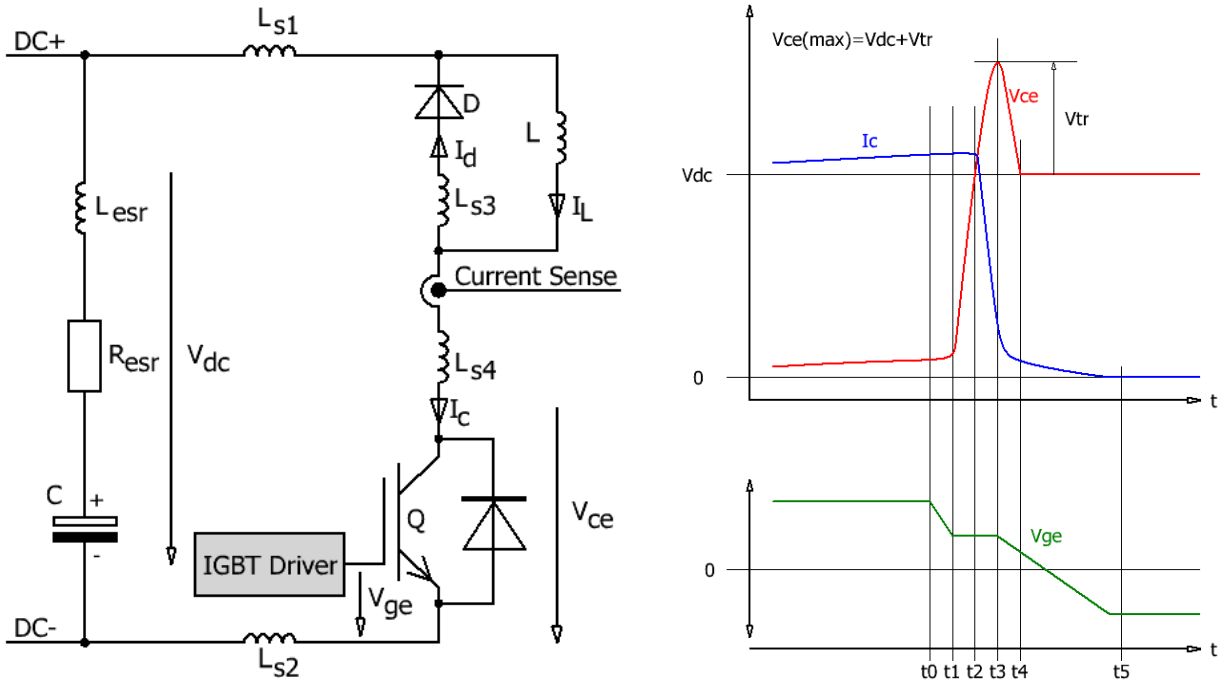

Fig. 11 Test circuit (left) and typical switching behavior (right)

Legend to Fig. 11

- t0 = Initiation of the turn-off process
- t1 = Start of turn-off time
- t2 = Start of collector current fall time
- t3 = Maximum collector voltage
- t4 = IGBT is blocking, start of tail current
- t5 = End of tail current

In comparison with other driving methods, active clamping allows enhanced utilization of the IGBT modules during normal operation by increasing the switching speed and therefore reducing switching losses. The overvoltage at fault-current turn-off is also managed by active clamping. For the maximum permitted DC-link voltage, refer to the gate driver data sheets [3].

Fig. 12 shows an exemplary turn-off transition of a 1400A/1200V IGBT module controlled with a 2SP0320T driver.

Preliminary Description and Application Manual

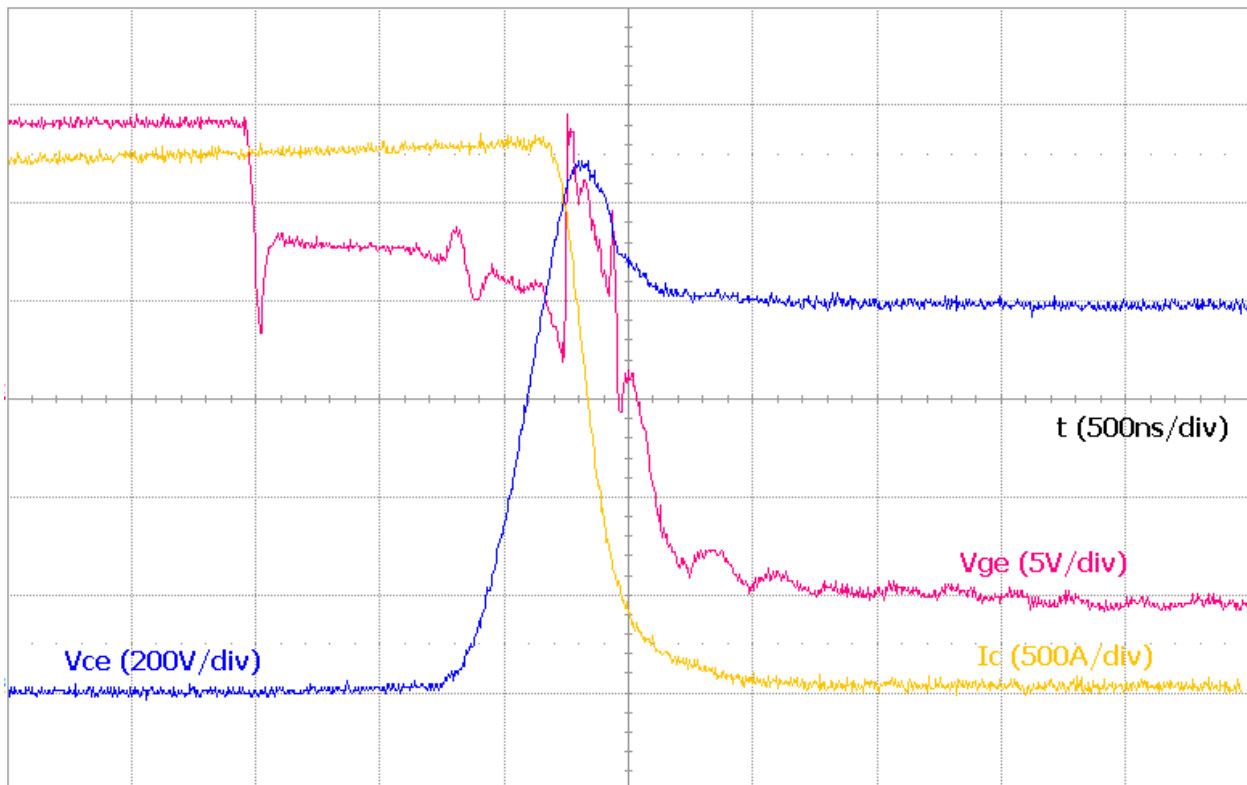

Fig. 12 Behavior of a 1400A/1200V IGBT module turning off at a DC-link voltage of 800V a collector current of 2800A, which is twice the nominal collector current

Parallel connection of 2SP0320T

2SP0320T SCALE-2 drivers with the corresponding IGBT module can be paralleled in order to increase the system power. This outstanding feature results directly from the very low propagation delay of the driver as well as the low jitter (see the corresponding data sheets for timing information /3/ as well as /5/ for more information on paralleling).

CONCEPT recommends users to proceed in the following way to use 2SP0320T drivers in parallel operation:

- The supply voltages VCC and VDC of all parallel connected drivers must come from the same voltage source in order to ensure symmetrical operation of the drivers.
- Both input signals INA and INB of all parallel connected drivers must come from the same logic buffer (driver) in order to ensure very small delay differences.
- The slew rate of INA and INB must be high enough ($> 0.25\text{V/ns}$) in order to minimize the delay jitter. In particular, if the input signals INA and INB are filtered with an RC network (e.g. for short pulse suppression), a Schmitt trigger buffer must be used to generate a high slew rate at INA and INB.
- The length difference of the interface cables from the host board to the driver connectors X1 should be less than 40cm for all parallel-connected drivers in order to keep the additional delay differences below about 2ns.
- All drivers must work in direct mode. The half-bridge mode is not suitable for parallel operation of 2SP0320T.
- In case of fault turn-off, it is necessary to wait until the fault feedback of all paralleled drivers is reset in order to ensure that the blocking time of all paralleled drivers has elapsed.

Preliminary Description and Application Manual

- The status outputs SO1 and SO2 of parallel-connected drivers can be evaluated individually to allow precise fault diagnosis, or they can be connected together.

Normal operation

In normal switching operation (no fault feedback), the paralleled drivers can be used in the same way as without parallel connection. All paralleled IGBT modules are switched on and off synchronously. Laboratory measurements have shown that small signal delay differences (<5ns) as well as small differences of the negative gate voltage (<0.4V) lead to a small redistribution of the collector current at turn-off or turn-on as well as of the switching losses. However, this is a minor effect and asymmetry due to the mechanical construction of the converter will dominate in most cases.

Short circuit

In case of a short circuit, the first driver that detects the short circuit will send a fault feedback back to the corresponding SOx output. The corresponding IGBT will be switched off after an additional delay of about 1.4µs. During this delay it is not possible to switch off the IGBT.

In the worst case condition, the user would (accidentally) try to switch off an IGBT module just after the short circuit has been detected by the first driver. In this case, the driver that has detected the short circuit would ignore the turn-off command. The drivers that have not yet detected the short circuit would turn the corresponding IGBTs off. This would lead to an asynchronous turn-off of the short circuit. However, laboratory measurements have shown that such asynchronous turn-off (delay difference up to 2µs) does not reveal any problems. Both low-inductance (~70nH) and high-inductance (>1.5µH) short circuits have been considered. However, CONCEPT recommends users to check this point in the specific application.

Supply undervoltage

In case of supply undervoltage, the corresponding driver will send a fault feedback back to the corresponding SOx output(s) and switch off the corresponding IGBT(s) immediately. It is then recommended to send a turn-off command to all paralleled drivers immediately. They will then switch off the corresponding IGBTs after a short delay.

3-level and multilevel topologies

If 2SP0320T drivers are to be used in 3-level or multilevel topologies, please refer to the Application Note AN-0901 /6/.

dV/dt feedback

The 2SP0320T driver family is optionally equipped with a dV/dt feedback that reduces the high dV/dt during IGBT turn-off. This feature can be used to reduce the turn-off overvoltage and/or to allow higher DC-link voltages. For more information about this feature, please consult CONCEPT's technical support service.

Low-inductance layout

The active-clamping function should not lead anyone to forget about the inductances of the power stack. For several reasons, it is still necessary to reduce the DC-link stray inductance to about 40nH...70nH with 2SP0320T plug-and-play drivers.

Preliminary Description and Application Manual

Higher requirements for traction applications or similar

The connector X1 provides a mechanical interlock.

The vibration withstand capability of 2SP0320T SCALE-2 drivers can be improved by screw-fitting the driver board onto the cooler (see Fig. 13).

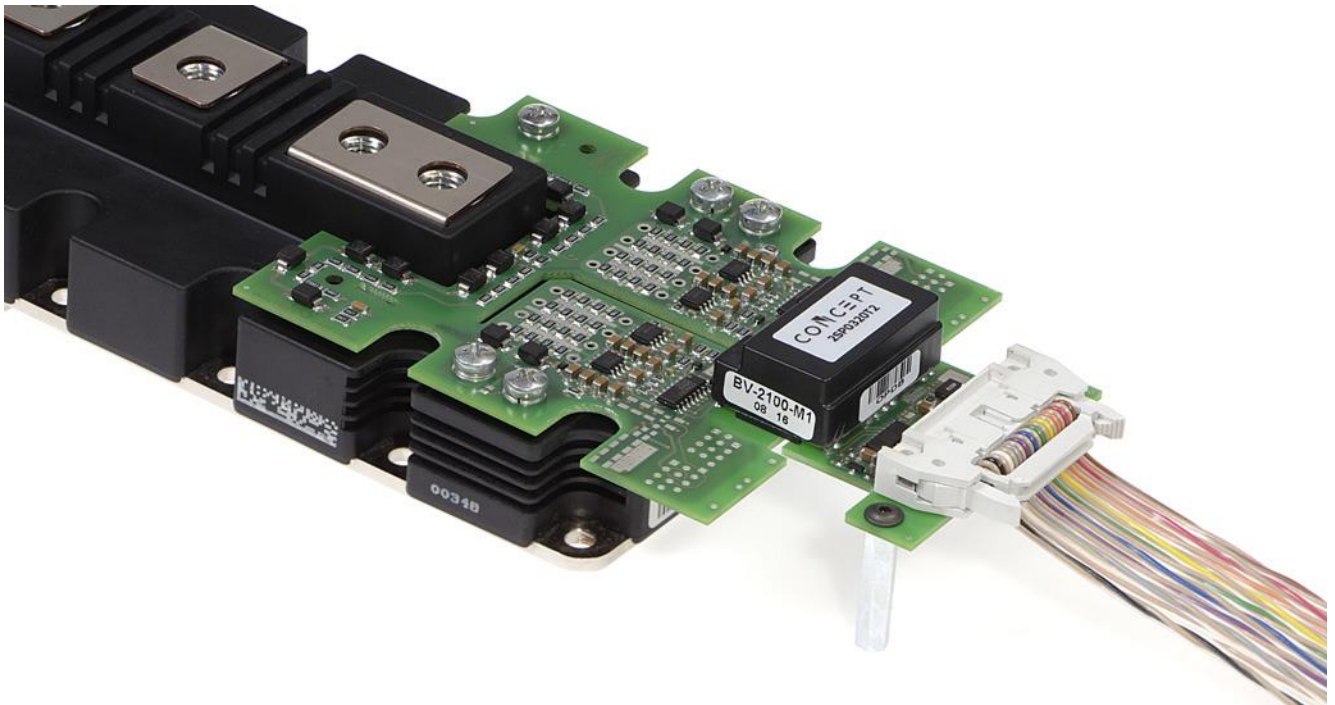

Fig. 13 Additional measures for fixing the driver

Bibliography

- /1/ Paper: Smart Power Chip Tuning, Bodo's Power Systems, May 2007
- /2/ "Description and Application Manual for SCALE™ Drivers", CONCEPT
- /3/ Data sheets SCALE™-2 plug-and-play driver 2SP0320x2xx-xxx, CONCEPT
- /4/ Paper: Driver Solutions for High-Voltage IGBTs, PCIM Europe Magazine, April 2002
- /5/ Paper: Intelligent Paralleling, Bodo's Power Systems, March 2009
- /6/ Application Note AN-0901: Methodology for Controlling Multi-Level Converter Topologies with SCALE™-2 IGBT Drivers, CONCEPT
- /7/ Application Note AN-1101: Application with SCALE™-2 Gate Driver Cores, CONCEPT

Note: The Application Notes are available on the Internet at www.igbt-driver.com/go/app-note and the papers at www.IGBT-Driver.com/go/paper

Preliminary Description and Application Manual

The Information Source: SCALE-2 Driver Data Sheets

CONCEPT offers the widest selection of gate drivers for power MOSFETs and IGBTs for almost any application needs. The largest website on gate-drive circuitry anywhere contains all data sheets, application notes and manuals, technical information and support sections: www.IGBT-Driver.com

Quite Special: Customized SCALE-2 Drivers

If you need an IGBT driver that is not included in the delivery range, please don't hesitate to contact CONCEPT or your CONCEPT sales partner.

CONCEPT has more than 25 years experience in the development and manufacture of intelligent gate drivers for power MOSFETs and IGBTs and has already implemented a large number of customized solutions.

Technical Support

CONCEPT provides expert help with your questions and problems:

www.IGBT-Driver.com/go/support

Quality

The obligation to high quality is one of the central features laid down in the mission statement of CT-Concept Technologie GmbH. The quality management system covers all stages of product development and production up to delivery. The drivers of the SCALE-2 series are manufactured to the ISO9001:2000 quality standard.

Legal Disclaimer

This data sheet specifies devices but cannot promise to deliver any specific characteristics. No warranty or guarantee is given – either expressly or implicitly – regarding delivery, performance or suitability.

CT-Concept Technologie GmbH reserves the right to make modifications to its technical data and product specifications at any time without prior notice. The general terms and conditions of delivery of CT-Concept Technologie GmbH apply.

Preliminary Description and Application Manual

Ordering Information

See the current list on www.IGBT-Driver.com/go/2SP0320

Refer to www.IGBT-Driver.com/go/nomenclature for information on driver nomenclature

The general terms and conditions of delivery of CT-Concept Technologie GmbH apply.

Information about Other Products

For drivers adapted to other high-voltage or high-power IGBT modules

Direct link: www.IGBT-Driver.com/go/plug-and-play

For other drivers, evaluation systems product documentation and application support

Please click onto: www.IGBT-Driver.com

Manufacturer

CT-Concept Technologie GmbH
A Power Integrations Company
Johann-Renfer-Strasse 15
2504 Biel-Bienne
Switzerland

Phone +41 - 32 - 344 47 47

Fax +41 - 32 - 344 47 40

E-mail Info@IGBT-Driver.com

Internet www.IGBT-Driver.com

© 2008...2014 CT-Concept Technologie GmbH - Switzerland.

We reserve the right to make any technical modifications without prior notice.

All rights reserved.

Version 2.1 from 2014-03-24

Mouser Electronics

Authorized Distributor

Click to View Pricing, Inventory, Delivery & Lifecycle Information:

Power Integrations:

[2SP0320T2A](#) [2SP0320T2B0-12](#) [2SP0320T2B0-FF1400R12IP4](#) [2SP0320T2D0-12](#) [2SP0320T2D0-17](#)
[2SP0320T2C0C-FF1200R12IE5](#)



Компания «ЭлектроПласт» предлагает заключение долгосрочных отношений при поставках импортных электронных компонентов на взаимовыгодных условиях!

Наши преимущества:

- Оперативные поставки широкого спектра электронных компонентов отечественного и импортного производства напрямую от производителей и с крупнейших мировых складов;
- Поставка более 17-ти миллионов наименований электронных компонентов;
- Поставка сложных, дефицитных, либо снятых с производства позиций;
- Оперативные сроки поставки под заказ (от 5 рабочих дней);
- Экспресс доставка в любую точку России;
- Техническая поддержка проекта, помощь в подборе аналогов, поставка прототипов;
- Система менеджмента качества сертифицирована по Международному стандарту ISO 9001;
- Лицензия ФСБ на осуществление работ с использованием сведений, составляющих государственную тайну;
- Поставка специализированных компонентов (Xilinx, Altera, Analog Devices, Intersil, Interpoint, Microsemi, Aeroflex, Peregrine, Syfer, Eurofarad, Texas Instrument, Miteq, Cobham, E2V, MA-COM, Hittite, Mini-Circuits, General Dynamics и др.);

Помимо этого, одним из направлений компании «ЭлектроПласт» является направление «Источники питания». Мы предлагаем Вам помощь Конструкторского отдела:

- Подбор оптимального решения, техническое обоснование при выборе компонента;
- Подбор аналогов;
- Консультации по применению компонента;
- Поставка образцов и прототипов;
- Техническая поддержка проекта;
- Защита от снятия компонента с производства.



Как с нами связаться

Телефон: 8 (812) 309 58 32 (многоканальный)

Факс: 8 (812) 320-02-42

Электронная почта: org@eplast1.ru

Адрес: 198099, г. Санкт-Петербург, ул. Калинина, дом 2, корпус 4, литера А.