

Specification

(Reference)

Title: FIXED THICK FILM CHIP RESISTORS;
RECTANGULAR TYPE & HIGH OHM

Style: RHC16,20

RoHS COMPLIANCE ITEM

Halogen and Antimony Free

Product specification contained in this specification
are subject to change at any time without notice
If you have any questions or a Purchasing Specification for any quality
Agreement is necessary, please contact our sales staff.



釜屋電機株式會社
KAMAYA ELECTRIC CO., LTD.

Issue Dept.: Research & Development Department Hokkaido Research Center

1. Scope

1.1 This specification covers the detail requirements for fixed thick film chip resistors; rectangular type & high ohm, style of RHC16,20.

1.2 Applicable documents

JIS C 5201: 1994, JIS C 5202: 1990

2. Classification

Type designation shall be the following form.

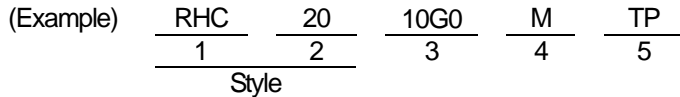

- 1 Fixed thick film chip resistors; rectangular type & high ohm Style
- 2 Size
- 3 Rated resistance Example; 10G0 → 10GΩ
- 4 Tolerance on rated resistance
- 5 Packaging form

3. Rating

3.1 The ratings shall be in accordance with Table-1.

Table-1

Style	Rated voltage (V)	Temperature coefficient of resistance (10 ⁻⁶ /°C)	Rated resistance range (Ω)	Tolerance on rated resistance	Preferred number series for resistors	Isolation voltage (V)
RHC16	15	0~2,000	100M~270M	J(±5%)	E12	100
			100M~4G	K(±10%)		
			100M~150G	M(±20%), N(±30%), H(±50%)		
RHC20		±2,000	100M~1G	J(±5%), K(±10%)		
			100M~10G	M(±20%), N(±30%), H(±50%)		
			100G~150G			

Style	Working temperature range(°C)
RHC16	-55~+155
RHC20	-55~+125

3.2 Derating

The derated values of load at temperature in excess of 70 °C shall be as indicated by the following curve.

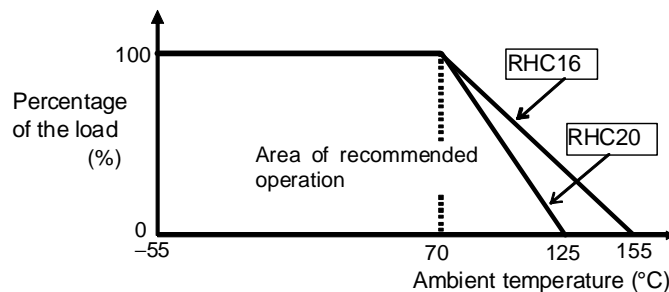

Figure-1 Derating curve

4. Packaging form

The standard packaging form shall be in accordance with Table-2.

Table-2

Symbol	Packaging form	Standard packaging quantity / units
B	Bulk (loose package)	1,000 pcs.
TP	Paper taping 8mm width, 4mm pitches	5,000 pcs.

5. Dimensions

5.1 The resistor shall be of the design and physical dimensions in accordance with Figure-2 and Table-3.

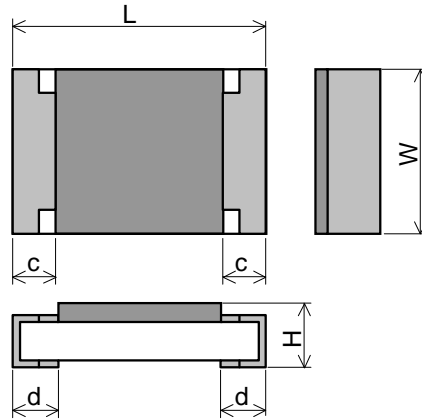

Figure-2

Table-3

Unit: mm

Style	L	W	H	c	d
RHC16	1.6±0.1	0.8 ^{+0.15} _{-0.05}	0.45±0.10	0.3±0.1	0.3±0.1
RHC20	2.0±0.1	1.25±0.10	0.55±0.10	0.4±0.2	0.4±0.2

5.2 Net weight (Reference)

Style	Net weight(mg)
RHC16	2
RHC20	5

6. Performance

6.1 The standard condition for tests shall be in accordance with Sub-clause 3, JIS C 5202: 1990.

6.2 The performance shall be satisfied in Table-4.

Table-4(1)

No.	Test items	Condition of test (JIS C 5202)	Performance requirements
1	DC resistance	Sub-clause 5.1 Measuring voltage: 15 V	Within the specified tolerance of rated resistance.
2	Temperature characteristics of resistance	Sub-clause 5.2 Test condition: 5 °C / 35 °C	See table-1.
3	Voltage coefficient	Sub-clause 5.3 Measuring voltage: 5 V / 15 V	RHC16 100MΩ≤R<100GΩ: Within ±1 %/V 100GΩ≤R≤150GΩ: Within ±2 %/V RHC20 100MΩ≤R≤10GΩ: Within 0—2 %/V 100GΩ≤R≤150GΩ: Within ±10 %/V
4	Insulation resistance	Sub-clause 5.6 The resistor shall be fixed on the test fixture as shown in Figure-4. Test potential: 100 Vdc Test period: 1 min.	10 TΩ min.
5	Capacitance	Measuring voltage: 1 V Measuring frequency: 10 kHz, 100kHz, 1MHz	1 pF max.

Table-4(2)

No.	Test items	Condition of test (JIS C 5202)	Performance requirements															
6	Terminal strength (Pulling test)	Lead wire (RHC16: $\phi 0.4$ mm, RHC20: $\phi 0.47$ mm) shall be soldered to the center of terminal. One side is fixed and the specified load shall be applied to the other side in the direction of axial. Duration: $10 \text{ s} \pm 1 \text{ s}$	Not be peeled off by the pulling force under 5 N. RHC16: 3 N															
7	Substrate bending test	Sub-clause 6.1.4 (1) The resistor shall be mounted on the test substrate as shown in Figure-3. Bending value: 5 mm (Among the fulcrums: 90 mm) Duration: $10 \text{ s} \pm 1 \text{ s}$	No evidence of mechanical damage.															
8	Resistance to soldering heat	Sub-clause 6.10 Test by a piece. Temp. of solder bath: $260 \text{ }^\circ\text{C} \pm 5 \text{ }^\circ\text{C}$ Immersion time: $10 \text{ s} \pm 1 \text{ s}$ After immersion into solder, leaving at the room temp. for 1h or more and then measure the resistance.	RHC16 $100\text{M}\Omega \leq R \leq 10\text{G}\Omega$: Within $\pm 1 \%$ $10\text{G}\Omega < R \leq 150\text{G}\Omega$: Within $\pm 2 \%$ RHC20 $100\text{M}\Omega \leq R \leq 10\text{G}\Omega$: Within $\pm 1 \%$ $100\text{G}\Omega \leq R \leq 150\text{G}\Omega$: Within $\pm 5 \%$ No evidence of appearance damage															
9	Solderability	Sub-clause 6.11 Test by a piece. Flux: Rosin-Methanol Temp. of solder bath: $235 \text{ }^\circ\text{C} \pm 5 \text{ }^\circ\text{C}$ Immersion time: $2 \text{ s} \pm 0.5 \text{ s}$	The surface of terminal immersed shall be min. of 95% covered with a new coating of solder.															
10	Temperature cycling	Sub-clause 7.4 Test cycle: 5 cycles for duty cycle as specified below.	RHC16 $100\text{M}\Omega \leq R \leq 10\text{G}\Omega$: Within $\pm 1 \%$ $10\text{G}\Omega < R \leq 150\text{G}\Omega$: Within $\pm 2 \%$ RHC20 $100\text{M}\Omega \leq R \leq 10\text{G}\Omega$: Within $\pm 1 \%$ $100\text{G}\Omega \leq R \leq 150\text{G}\Omega$: Within $\pm 5 \%$ No evidence of appearance damage															
		<table border="1"> <thead> <tr> <th>Step</th> <th>Temperature ($^\circ\text{C}$)</th> <th>Time (min)</th> </tr> </thead> <tbody> <tr> <td>1</td> <td>Room temp.</td> <td>2-3</td> </tr> <tr> <td>2</td> <td>-55 ± 3</td> <td>30</td> </tr> <tr> <td>3</td> <td>Room temp.</td> <td>2-3</td> </tr> <tr> <td>4</td> <td>RHC16: 155 ± 2 RHC20: 125 ± 2</td> <td>30</td> </tr> </tbody> </table>		Step	Temperature ($^\circ\text{C}$)	Time (min)	1	Room temp.	2-3	2	-55 ± 3	30	3	Room temp.	2-3	4	RHC16: 155 ± 2 RHC20: 125 ± 2	30
		Step		Temperature ($^\circ\text{C}$)	Time (min)													
		1		Room temp.	2-3													
		2		-55 ± 3	30													
3	Room temp.	2-3																
4	RHC16: 155 ± 2 RHC20: 125 ± 2	30																
11	Humidity	Sub-clause 7.5 Test temp. & relative humidity: $40 \text{ }^\circ\text{C} \pm 2 \text{ }^\circ\text{C}$ & 90-95 % Test period: $1,000 \text{ }^{+48}_0 \text{ h}$	RHC16 $100\text{M}\Omega \leq R \leq 10\text{G}\Omega$: Within $\pm 2 \%$ $10\text{G}\Omega < R \leq 150\text{G}\Omega$: Within $\pm 5 \%$ RHC20 $100\text{M}\Omega \leq R \leq 10\text{G}\Omega$: Within $\pm 2 \%$ $100\text{G}\Omega \leq R \leq 150\text{G}\Omega$: Within $\pm 5 \%$ No evidence of appearance damage															
12	Load life	Sub-clause 7.10 Test temp. & relative humidity: $70 \text{ }^\circ\text{C} \pm 2 \text{ }^\circ\text{C}$ Test voltage: Cycle of 1 h 30 min. "ON" and 30 min. "OFF" at dc rated voltage. Test period: $1,000 \text{ }^{+48}_0 \text{ h}$	RHC16 $100\text{M}\Omega \leq R \leq 10\text{G}\Omega$: Within $\pm 3 \%$ $10\text{G}\Omega < R \leq 150\text{G}\Omega$: Within $\pm 5 \%$ RHC20 $100\text{M}\Omega \leq R \leq 10\text{G}\Omega$: Within $\pm 3 \%$ $100\text{G}\Omega \leq R \leq 150\text{G}\Omega$: Within $\pm 20 \%$ No evidence of appearance damage															

7. Test substrate

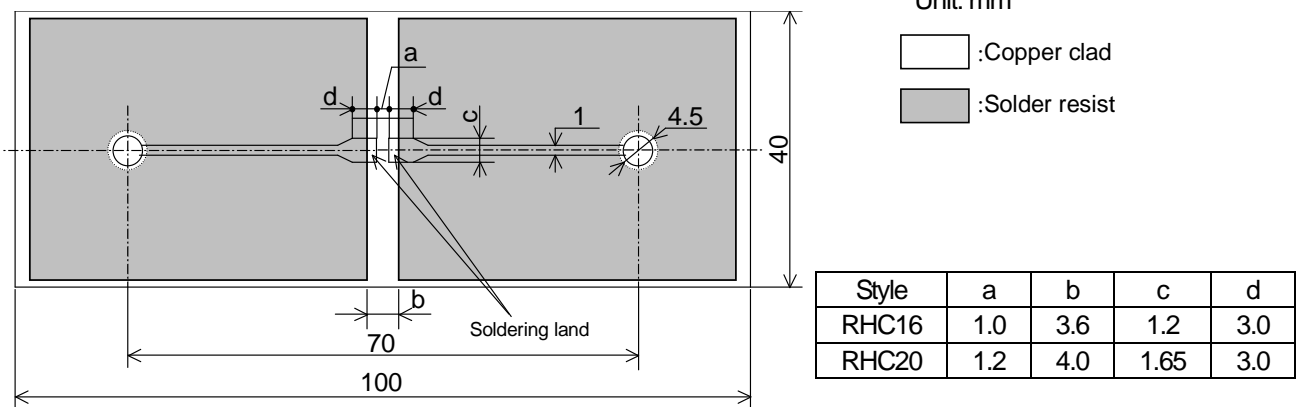

Figure-3 RHC BOUND STRENGTH OF THE END FACE PLATING TEST SUBSTRATE

Remark 1). Material: Epoxide woven glass
Thickness: 1.6mm Thickness of copper clad: 0.035mm

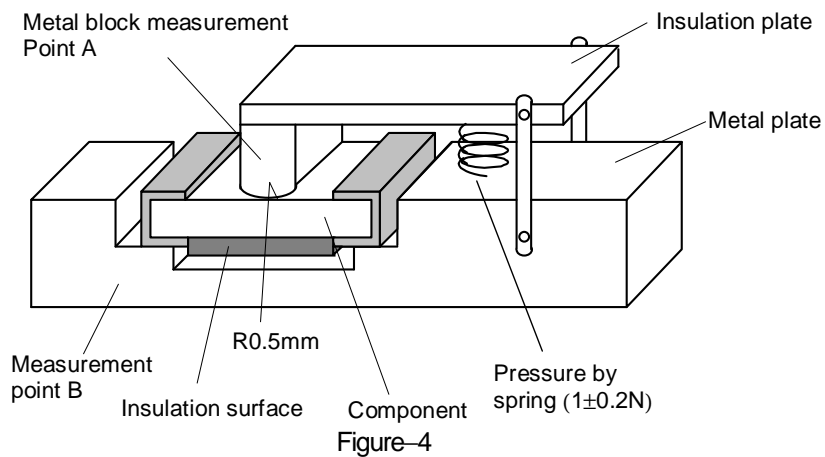

Figure-4

8. Taping

8.1 Applicable documents JIS C 0806-3: 1999, EIAJ ET-7200B: 2003

8.2 Taping dimensions

Paper taping (8mm width, 4mm pitches)

Taping dimensions shall be in accordance with Figure-5 and Table-5.

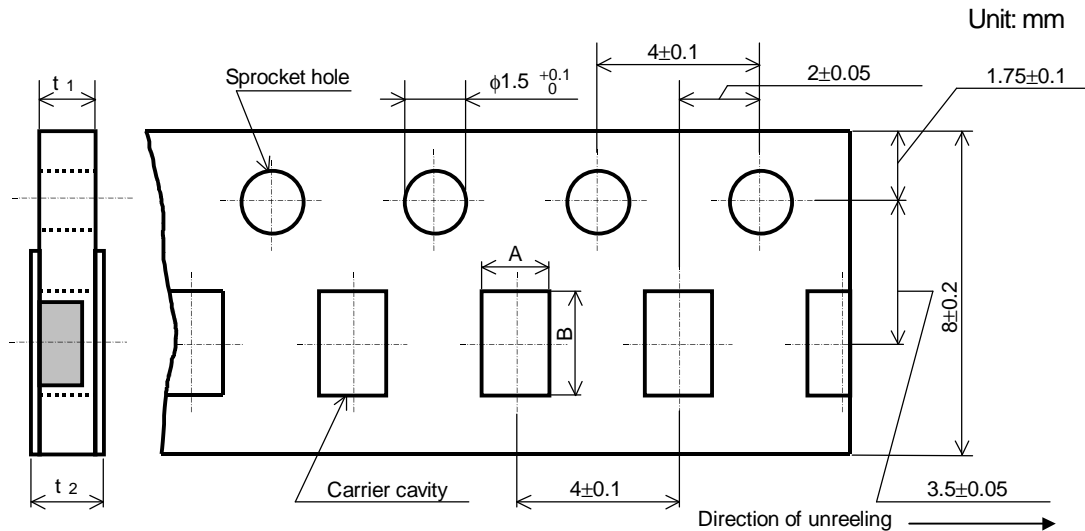

Figure-5

Table-5

Unit: mm

Style	A	B	t ₁	t ₂
RHC16	1.15±0.15	1.9±0.2	0.6±0.1	0.8max.
RHC20	1.65±0.15	2.5±0.2	0.8±0.1	1.0max.

- 1). The cover tapes shall not cover the sprocket holes.
- 2). Tapes in adjacent layers shall not stick together in the packing.
- 3). Components shall not stick to the carrier tape or to the cover tape.
- 4). Pitch tolerance over any 10 pitches ±0.2mm.
- 5). The peel strength of the top cover tape shall be within 0.1N to 0.5N on the test method as shown in the following Figure-6.
- 6). When the tape is bent with the minimum radius for 25 mm, the tape shall not be damaged and the components shall maintain their position and orientation in the tape.
- 7). In no case shall there be two or more consecutive components missing.
The maximum number of missing components shall be one or 0.1%, whichever is greater.
- 8). The resistors shall be faced to upward at the over coating side in the carrier cavity.

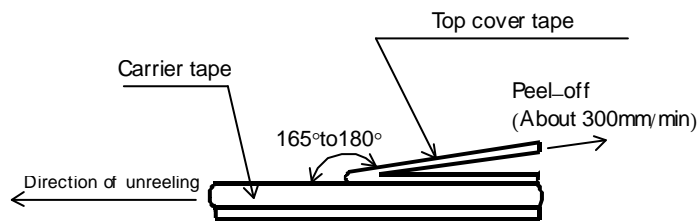

Figure-6

8.3 Reel dimension

Reel dimensions shall be in accordance with the following Figure-7 and Table-6.
Plastic reel (Based on EIAJ ET-7200B)

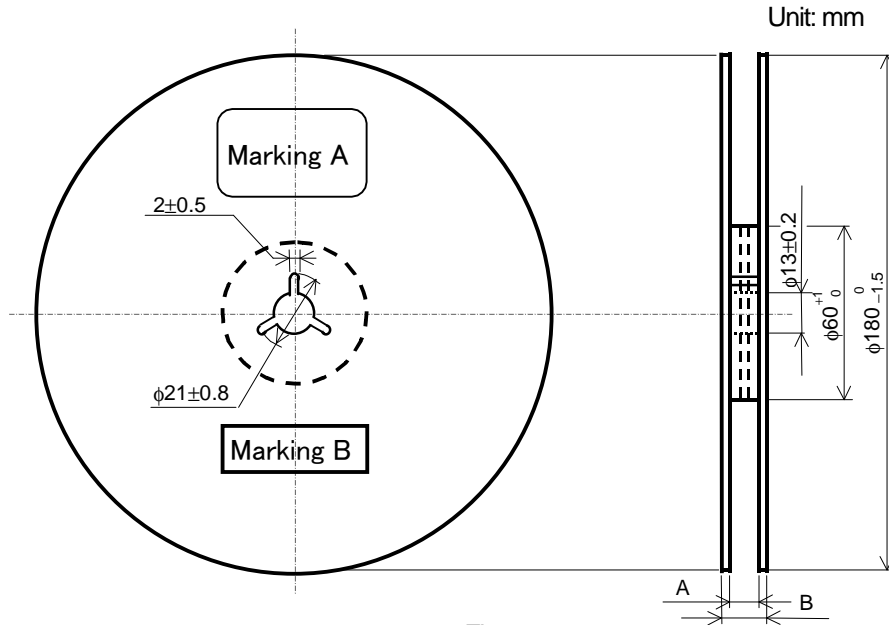

Figure-7

Table-6

Unit: mm			
Style	A	B	Note
RHC16, 20	9 ^{+1.0} / ₀	11.4 ± 1.0	Injection molding
		13 ± 1.0	Vacuum forming

Note: Marking label shall be marked on a place of Marking A or two place of marking A and B.

8.4 Leader and trailer tape.

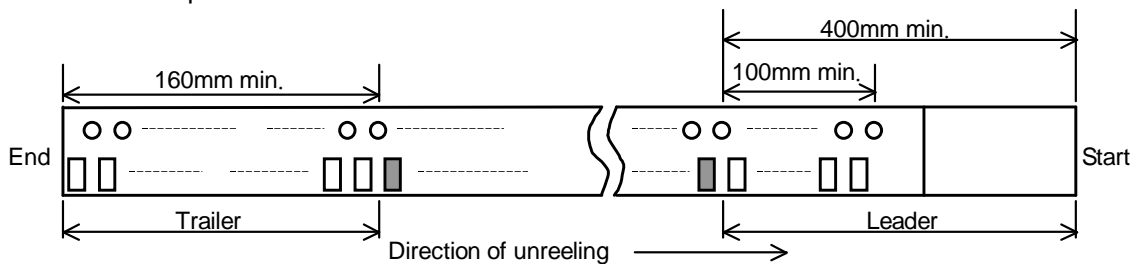

Figure-8

9. Marking on package

The label of a minimum package shall be legibly marked with follows.

9.1 Marking A

- (1) Classification (Style, Rated resistance, Tolerance on rated resistance, Packaging form)
- (2) Quantity (3) Lot number (4) Manufacturer's name or trade mark (5) Others

9.2 Marking B (KAMAYA Control label)

Mouser Electronics

Authorized Distributor

Click to View Pricing, Inventory, Delivery & Lifecycle Information:

Kamaya:

[RZC63-105JTE](#) [RZC50-156JTE](#) [RPC32100MTP](#) [RPC504R7KTE](#) [RPC20182MTP](#) [RPC63471KTE](#) [RPC35150MTE](#)
[RPC35275MTE](#) [RPC321R1MTP](#) [RPC20122KTP](#) [RPC35104JTE](#) [RPC20152JTP](#) [RPC63101KTE](#) [RPC202R7MTP](#)
[RPC20330JTP](#) [RPC20182JTP](#) [RPC35113MTE](#) [RPC50111JTE](#) [RPC63221KTE](#) [RPC35303JTE](#) [RPC32102JTP](#)
[RPC63470KTE](#) [RPC35200JTE](#) [RPC20161MTP](#) [RPC50331MTE](#) [RPC50270JTE](#) [RPC35244MTE](#) [RPC32104JTP](#)
[RPC35820JTE](#) [RPC20153KTP](#) [RPC35150JTE](#) [RPC35305MTE](#) [RPC63470JTE](#) [RPC50511MTE](#) [RPC20100JTP](#)
[RPC63390KTE](#) [RPC32220KTP](#) [RPC35135JTE](#) [RPC35120JTE](#) [RPC63183JTE](#) [RPC63101JTE](#) [RPC20102KTP](#)
[RPC20751MTP](#) [RPC35100JTE](#) [RPC32332JTP](#) [RPC63100JTE](#) [RPC35115MTE](#) [RPC50100KTE](#) [RPC32104MTP](#)
[RPC321R0JTP](#) [RPC503R0JTE](#) [RPC63181JTE](#) [RPC32435JTP](#) [RPC32755MTP](#) [RPC35244JTE](#) [RPC35303MTE](#)
[RPC503R3JTE](#) [RPC20334JTP](#) [RPC632R2JTE](#) [RPC63106JTE](#) [RHC2010G0MTP](#) [RHC161G20HTP](#)
[RHC16100MJTP](#) [RHC20330MKTP](#) [RHC162G20HTP](#) [RHC168G20MTP](#) [RHC20100GMTP](#) [RHC205G60HTP](#)
[RHC16100MKTP](#)



Компания «ЭлектроПласт» предлагает заключение долгосрочных отношений при поставках импортных электронных компонентов на взаимовыгодных условиях!

Наши преимущества:

- Оперативные поставки широкого спектра электронных компонентов отечественного и импортного производства напрямую от производителей и с крупнейших мировых складов;
- Поставка более 17-ти миллионов наименований электронных компонентов;
- Поставка сложных, дефицитных, либо снятых с производства позиций;
- Оперативные сроки поставки под заказ (от 5 рабочих дней);
- Экспресс доставка в любую точку России;
- Техническая поддержка проекта, помощь в подборе аналогов, поставка прототипов;
- Система менеджмента качества сертифицирована по Международному стандарту ISO 9001;
- Лицензия ФСБ на осуществление работ с использованием сведений, составляющих государственную тайну;
- Поставка специализированных компонентов (Xilinx, Altera, Analog Devices, Intersil, Interpoint, Microsemi, Aeroflex, Peregrine, Syfer, Eurofarad, Texas Instrument, Miteq, Cobham, E2V, MA-COM, Hittite, Mini-Circuits, General Dynamics и др.);

Помимо этого, одним из направлений компании «ЭлектроПласт» является направление «Источники питания». Мы предлагаем Вам помощь Конструкторского отдела:

- Подбор оптимального решения, техническое обоснование при выборе компонента;
- Подбор аналогов;
- Консультации по применению компонента;
- Поставка образцов и прототипов;
- Техническая поддержка проекта;
- Защита от снятия компонента с производства.



Как с нами связаться

Телефон: 8 (812) 309 58 32 (многоканальный)

Факс: 8 (812) 320-02-42

Электронная почта: org@eplast1.ru

Адрес: 198099, г. Санкт-Петербург, ул. Калинина, дом 2, корпус 4, литера А.