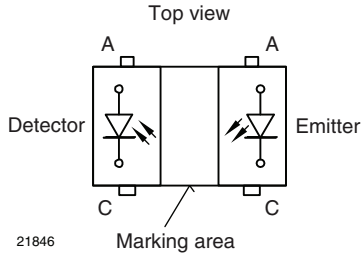


## Reflective Optical Sensor with PIN Photodiode Output



19967



21846

### DESCRIPTION

The TCND5000 is a reflective sensor that includes an infrared emitter and pin photodiode in a surface mount package which blocks visible light.

### FEATURES

- Package type: surface mount
- Detector type: pin photodiode
- Dimensions (L x W x H in mm): 6 x 4.3 x 3.75
- Peak operating distance: 6 mm
- Operating range within > 20 % relative collector current: 2 mm to 25 mm
- Typical output current under test:  $I_{ra} > 0.11 \mu A$
- Daylight blocking filter
- High linearity
- Emitter wavelength: 940 nm
- Lead (Pb)-free soldering released
- Moisture sensitivity level (MSL): 4
- Compliant to RoHS Directive 2002/95/EC and in accordance to WEEE 2002/96/EC


**RoHS**  
COMPLIANT

### APPLICATIONS

- Proximity sensor
- Object sensor
- Motion sensor
- Touch key

### PRODUCT SUMMARY

PART NUMBER	DISTANCE FOR MAXIMUM CTR <sub>rel</sub> <sup>(1)</sup> (mm)	DISTANCE RANGE FOR RELATIVE I <sub>out</sub> > 20 % (mm)	TYPICAL OUTPUT CURRENT UNDER TEST <sup>(2)</sup> (mA)	DAYLIGHT BLOCKING FILTER INTEGRATED
TCND5000	6	2 to 25	0.15	Yes

#### Notes

- (1) CTR: current transference ratio,  $I_{out}/I_{in}$   
 (2) Conditions like in table basic characteristics/sensors

### ORDERING INFORMATION

ORDERING CODE	PACKAGING	VOLUME <sup>(1)</sup>	REMARKS
TCND5000	Tape and reel	MOQ: 2000 pcs, 2000 pcs/reel	Drypack

#### Note

- (1) MOQ: minimum order quantity

### ABSOLUTE MAXIMUM RATINGS (T<sub>amb</sub> = 25 °C, unless otherwise specified)

PARAMETER	TEST CONDITION	SYMBOL	VALUE	UNIT
<b>INPUT (EMITTER)</b>				
Reverse voltage		V <sub>R</sub>	5	V
Forward current		I <sub>F</sub>	100	mA
Peak forward current	t <sub>p</sub> = 50 μs, t = 2 ms, T <sub>amb</sub> ≤ 25 °C	I <sub>FM</sub>	500	mA
Power dissipation		P <sub>V</sub>	190	mW
Junction temperature		T <sub>j</sub>	100	°C

<b>ABSOLUTE MAXIMUM RATINGS</b> ( $T_{amb} = 25\text{ }^{\circ}\text{C}$ , unless otherwise specified)				
PARAMETER	TEST CONDITION	SYMBOL	VALUE	UNIT
<b>OUTPUT (DETECTOR)</b>				
Reverse voltage		$V_R$	60	V
Power dissipation		$P_V$	75	mW
Junction temperature		$T_j$	100	$^{\circ}\text{C}$
<b>SENSOR</b>				
Ambient temperature range		$T_{amb}$	- 40 to + 85	$^{\circ}\text{C}$
Storage temperature range		$T_{stg}$	- 40 to + 100	$^{\circ}\text{C}$
Soldering temperature	acc. fig. 14	$T_{sd}$	260	$^{\circ}\text{C}$

## ABSOLUTE MAXIMUM RATINGS

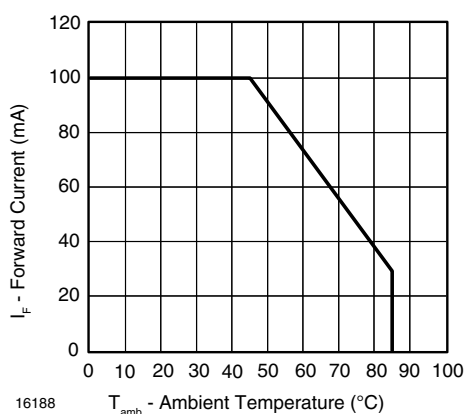


Fig. 1 - Forward Current Limit vs. Ambient Temperature

<b>BASIC CHARACTERISTICS</b> ( $T_{amb} = 25\text{ }^{\circ}\text{C}$ , unless otherwise specified)						
PARAMETER	TEST CONDITION	SYMBOL	MIN.	TYP.	MAX.	UNIT
<b>INPUT (EMITTER) <sup>(1)</sup></b>						
Forward voltage	$I_F = 50\text{ mA}$ , $t_p = 20\text{ ms}$	$V_F$		1.2	1.5	V
Temperature coefficient of $V_F$	$I_F = 1\text{ mA}$	$TK_{V_F}$		- 1.3		mV/K
Reverse current	$V_R = 5\text{ V}$	$I_R$			10	$\mu\text{A}$
Junction capacitance	$V_R = 0\text{ V}$ , $f = 1\text{ MHz}$ , $E = 0\text{ lx}$	$C_j$		25		pF
Radiant intensity	$I_F = 20\text{ mA}$ , $t_p = 20\text{ ms}$	$I_e$		7	75	mW/sr
Angle of half intensity		$\phi$		$\pm 12$		deg
Peak wavelength	$I_F = 100\text{ mA}$	$\lambda_p$	930	940		nm
Spectral bandwidth	$I_F = 100\text{ mA}$	$\Delta\lambda$		50		nm
Temperature coefficient of $\lambda_p$	$I_F = 100\text{ mA}$	$TK_{\lambda_p}$		0.2		nm/K
Rise time	$I_F = 100\text{ mA}$	$t_r$		800		ns
Fall time	$I_F = 100\text{ mA}$	$t_f$		800		ns
Virtual source diameter	Method: 63 % encircled energy	$d$		1.2		mm

<b>BASIC CHARACTERISTICS</b> ( $T_{amb} = 25\text{ }^{\circ}\text{C}$ , unless otherwise specified)						
PARAMETER	TEST CONDITION	SYMBOL	MIN.	TYP.	MAX.	UNIT
<b>OUTPUT (DETECTOR) <sup>(2)</sup></b>						
Forward voltage	$I_F = 50\text{ mA}$	$V_F$		1	1.3	V
Breakdown voltage	$I_R = 100\text{ }\mu\text{A}$	$V_{BR}$	60			V
Reverse dark current	$V_R = 10\text{ V}$ , $E = 0\text{ lx}$	$I_{ro}$		1	10	nA
Diode capacitance	$V_R = 5\text{ V}$ , $f = 1\text{ MHz}$ , $E = 0\text{ lx}$	$C_D$		1.8		pF
Reverse light current	$E_o = 1\text{ mW/cm}^2$ , $\lambda = 950\text{ nm}$ , $V_R = 5\text{ V}$	$I_{ra}$		12		$\mu\text{A}$
Temperature coefficient of $I_{ra}$	$\lambda = 870\text{ nm}$ , $V_R = 5\text{ V}$	$TK_{I_{ra}}$		0.2		%/K
Angle of half intensity		$\phi$		$\pm 15$		deg
Wavelength of peak sensitivity		$\lambda_P$		930		nm
Range of spectral bandwidth		$\lambda_{0.5}$		840 to 1050		nm
<b>SENSOR</b>						
Reverse Light Current	$V_R = 2.5\text{ V}$ , $I_F = 20\text{ mA}$ , $D = 30\text{ mm}$ , reflective mode: see figure 2	$I_{ra}$	110			nA

**Note**

- (1) See figures 2 to 8 accordingly  
 (2) See figures 9 to 12 accordingly

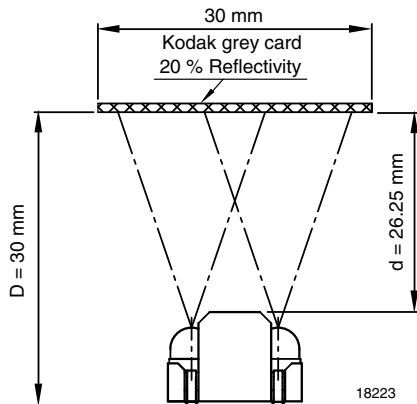


Fig. 2 - Test Circuit

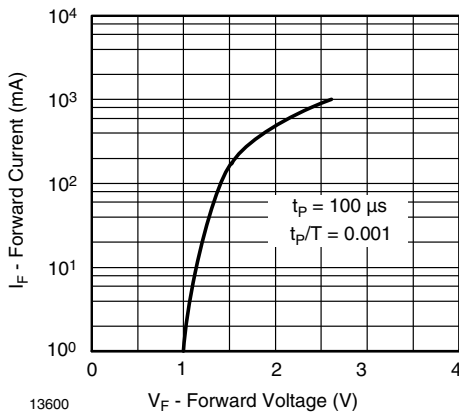
**BASIC CHARACTERISTICS** ( $T_{amb} = 25\text{ }^{\circ}\text{C}$ , unless otherwise specified)


Fig. 3 - Forward Current vs. Forward Voltage

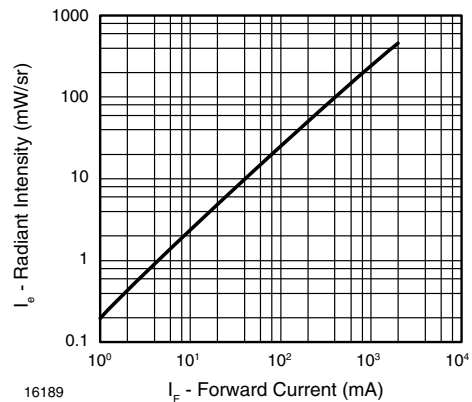


Fig. 4 - Radiant Intensity vs. Forward Current

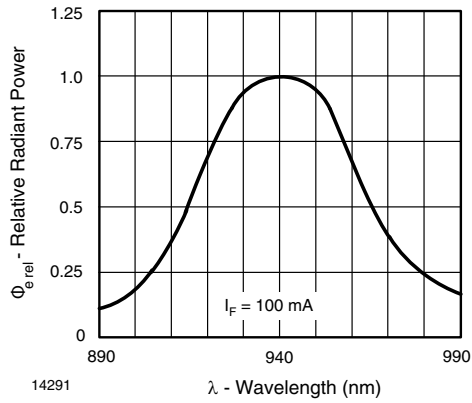


Fig. 5 - Relative Radiant Power vs. Wavelength

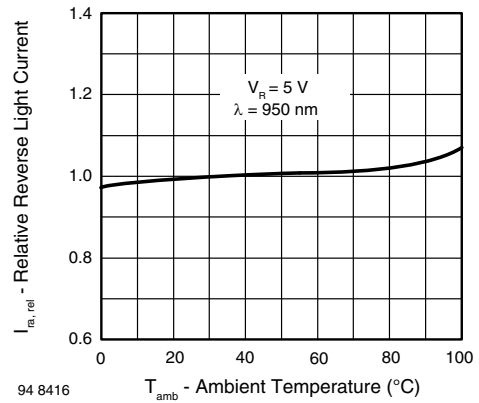


Fig. 8 - Relative Reverse Light Current vs. Ambient Temperature

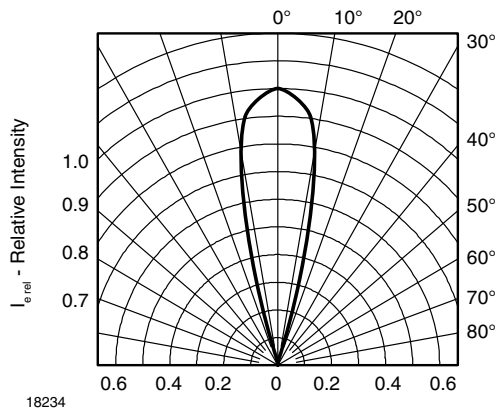


Fig. 6 - Relative Radiant Intensity vs. Angular Displacement

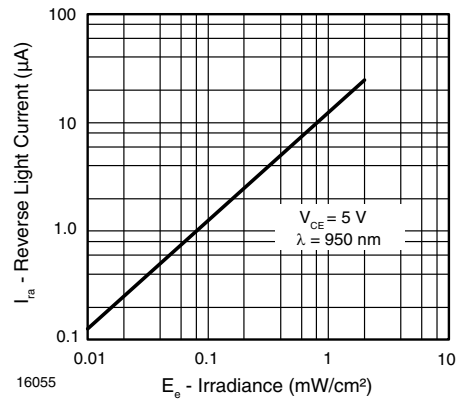


Fig. 9 - Reverse Light Current vs. Irradiance

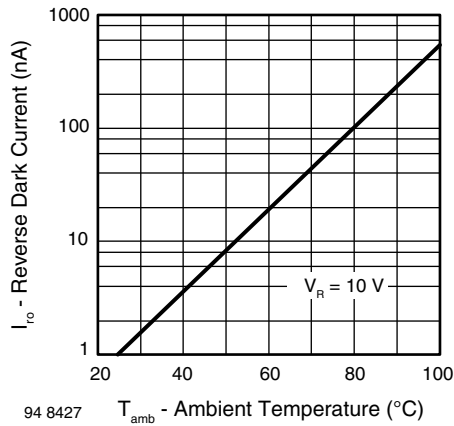


Fig. 7 - Reverse Dark Current vs. Ambient Temperature

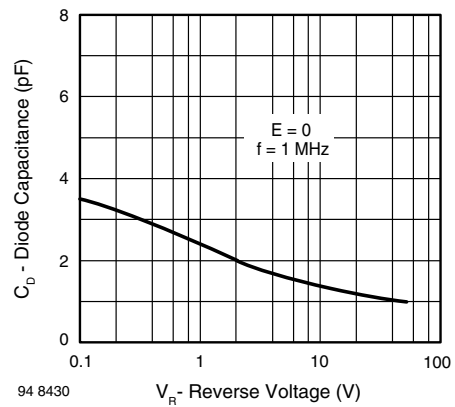


Fig. 10 - Diode Capacitance vs. Reverse Voltage

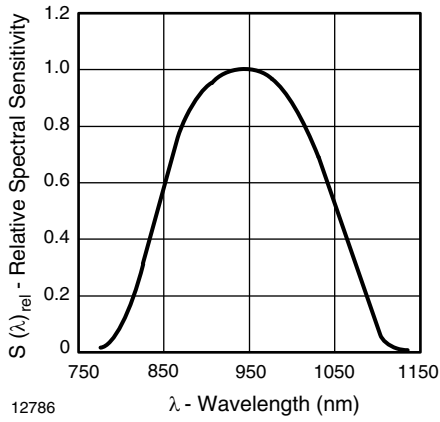


Fig. 11 - Relative Spectral Sensitivity vs. Wavelength

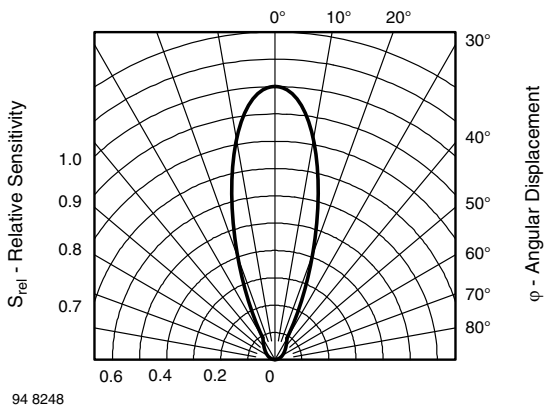


Fig. 12 - Relative Radiant Sensitivity vs. Angular Displacement

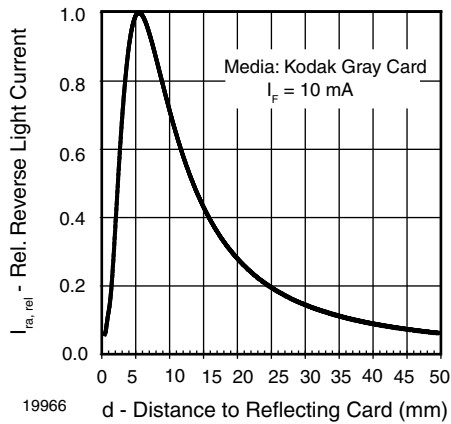
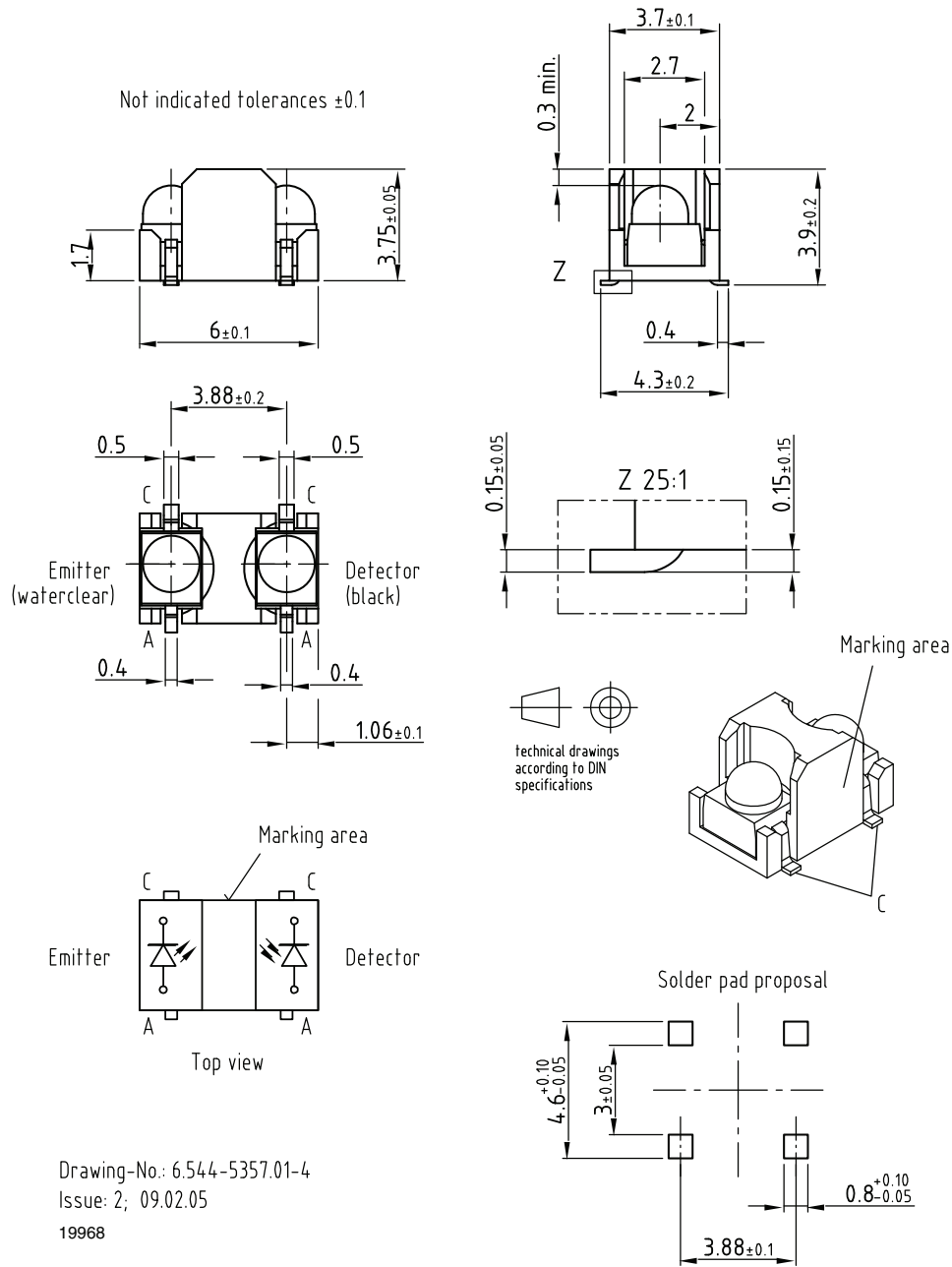


Fig. 13 - Relative Reverse Light Current vs. Distance



**PACKAGE DIMENSIONS** in millimeters


**PRECAUTIONS FOR USE**

**1. Over-current-proof**

Customer must apply resistors for protection, otherwise slight voltage shift will cause big current change (Burn out will happen).

**2. Storage**

2.1 Storage temperature and rel. humidity conditions are: 5 °C to 30 °C, RH 60 %

2.2 Floor life must not exceed 72 h, acc. to JEDEC level 4, J-STD-020.

Once the package is opened, the products should be used within 72 h. Otherwise, they should be kept in a damp proof box with desiccant.

Considering tape life, we suggest to use products within one year from production date.

2.3 If opened more than 72 h in an atmosphere 5 °C to 30 °C, RH 60 %, devices should be treated at 60 °C ± 5 °C for 15 h.

2.4 If humidity indicator in the package shows pink color (normal blue), then devices should be treated with the same conditions as 2.3

**REFLOW SOLDER PROFILES**

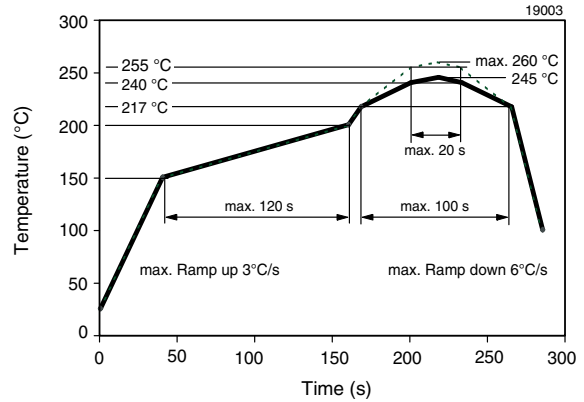


Fig. 14 - Lead (Pb)-Free Reflow Solder Profile

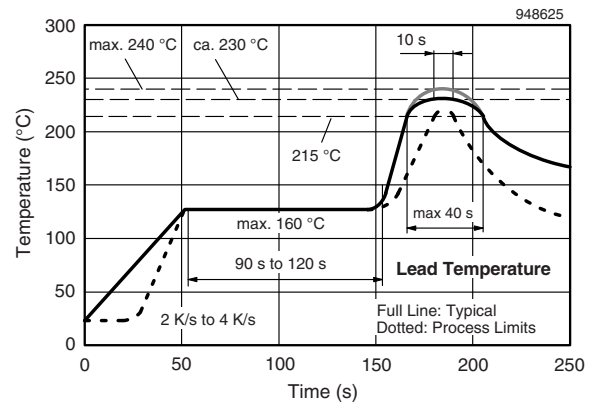


Fig. 15 - Lead Tin (SnPb) Reflow Solder Profile



## Packaging and Ordering Information

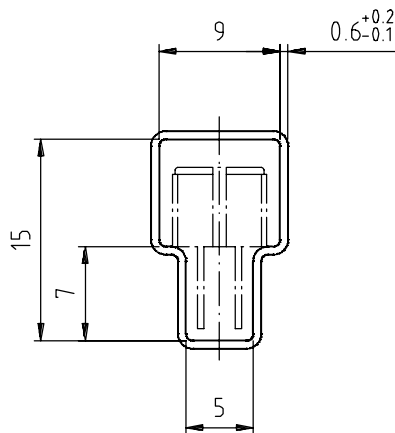
PART NUMBER	MOQ <sup>(1)</sup>	PCS PER TUBE	TUBE SPEC. (FIGURE)	CONSTITUENTS (FORMS)
CNY70	4000	80	1	28
TCPT1300X01	2000	Reel	(2)	29
TCRT1000	1000	Bulk	-	26
TCRT1010	1000	Bulk	-	26
TCRT5000	4500	50	2	27
TCRT5000L	2400	48	3	27
TCST1030	5200	65	5	24
TCST1030L	2600	65	6	24
TCST1103	1020	85	4	24
TCST1202	1020	85	4	24
TCST1230	4800	60	7	24
TCST1300	1020	85	4	24
TCST2103	1020	85	4	24
TCST2202	1020	85	4	24
TCST2300	1020	85	4	24
TCST5250	4860	30	8	24
TCUT1300X01	2000	Reel	(2)	29
TCZT8020-PAER	2500	Bulk	-	22

### Notes

(1) MOQ: minimum order quantity

(2) Please refer to datasheets

### TUBE SPECIFICATION FIGURES



With rubber stopper

Tolerance:  $\pm 0.5\text{mm}$

Length:  $575 \pm 1\text{mm}$

Drawing-No.: 9.700-5097.01-4

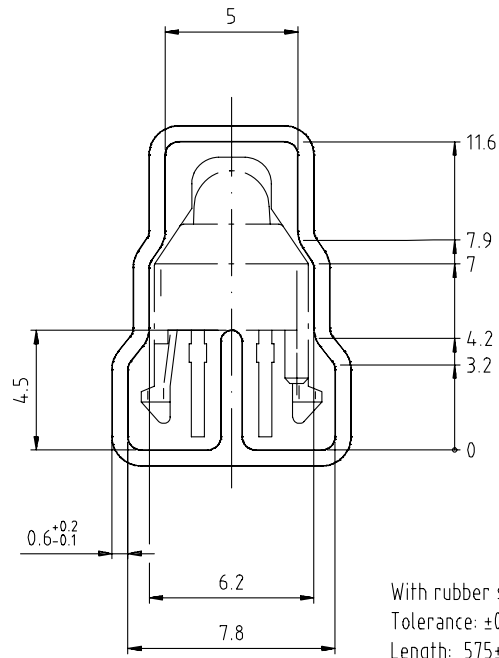
Issue: 1; 25.02.00

15198

Fig. 1

# Packaging and Ordering Information

Vishay Semiconductors Packaging and Ordering Information



Drawing-No.: 9.700-5139.01-4  
Issue: 1; 10.05.00

Drawing refers to following types: TCRT 5000

15210

Fig. 2



With stopper pins  
Tolerance: ±0.5mm  
Length: 575±1mm

Drawing-No.: 9.700-5178.01-4  
Issue: 1; 25.02.00

15201

Fig. 3

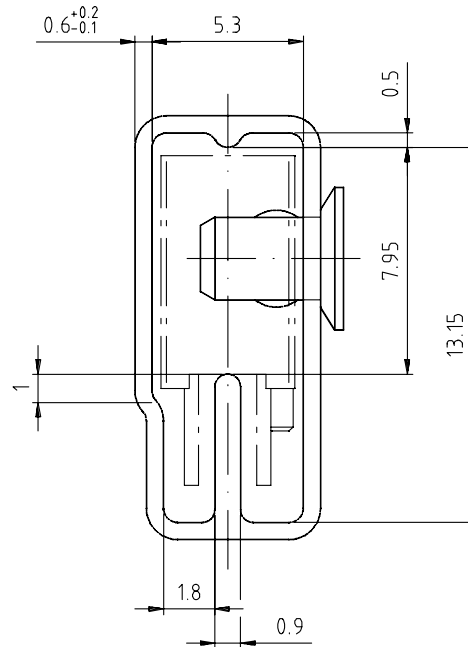


With rubber stopper  
Tolerance: ±0.5mm  
Length: 575±1mm

Drawing-No.: 9.700-5100.01-4  
Issue: 1; 25.02.00

15199

Fig. 4



With stopper pins  
Tolerance: ±0.5mm  
Length: 575±1mm

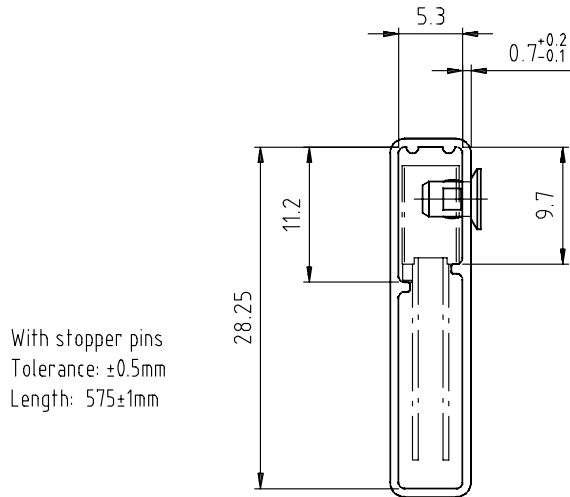
Drawing-No.: 9.700-5140.01-4  
Issue: 1; 25.02.00

15202

Fig. 5

# Packaging and Ordering Information

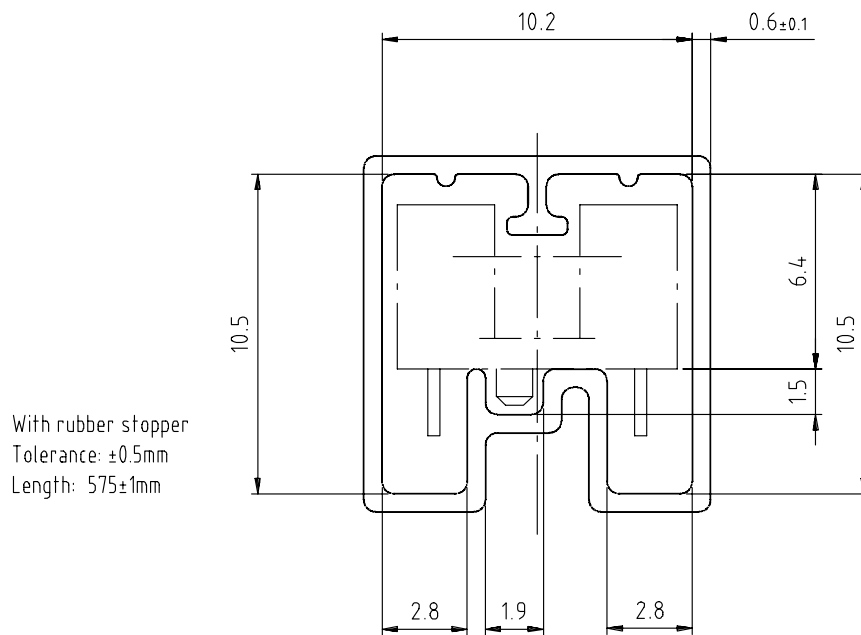
Vishay Semiconductors Packaging and Ordering Information



Drawing-No.: 9.700-5205.01-4  
Issue: 1; 25.02.00

15196

Fig. 6



Drawing-No.: 9.700-5245.01-4  
Issue: 1; 25.02.00

15195

Fig. 7



Drawing-No.: 9.700-5222.01-4  
 Issue: 2, 19.11.04  
 20257

With stopper pins  
 Tolerance:  $\pm 0.5\text{mm}$   
 Length:  $450 \pm 1\text{mm}$   
 All dimensions in mm

Fig. 8



## Disclaimer

ALL PRODUCT, PRODUCT SPECIFICATIONS AND DATA ARE SUBJECT TO CHANGE WITHOUT NOTICE TO IMPROVE RELIABILITY, FUNCTION OR DESIGN OR OTHERWISE.

Vishay Intertechnology, Inc., its affiliates, agents, and employees, and all persons acting on its or their behalf (collectively, "Vishay"), disclaim any and all liability for any errors, inaccuracies or incompleteness contained in any datasheet or in any other disclosure relating to any product.

Vishay makes no warranty, representation or guarantee regarding the suitability of the products for any particular purpose or the continuing production of any product. To the maximum extent permitted by applicable law, Vishay disclaims (i) any and all liability arising out of the application or use of any product, (ii) any and all liability, including without limitation special, consequential or incidental damages, and (iii) any and all implied warranties, including warranties of fitness for particular purpose, non-infringement and merchantability.

Statements regarding the suitability of products for certain types of applications are based on Vishay's knowledge of typical requirements that are often placed on Vishay products in generic applications. Such statements are not binding statements about the suitability of products for a particular application. It is the customer's responsibility to validate that a particular product with the properties described in the product specification is suitable for use in a particular application. Parameters provided in datasheets and/or specifications may vary in different applications and performance may vary over time. All operating parameters, including typical parameters, must be validated for each customer application by the customer's technical experts. Product specifications do not expand or otherwise modify Vishay's terms and conditions of purchase, including but not limited to the warranty expressed therein.

Except as expressly indicated in writing, Vishay products are not designed for use in medical, life-saving, or life-sustaining applications or for any other application in which the failure of the Vishay product could result in personal injury or death. Customers using or selling Vishay products not expressly indicated for use in such applications do so at their own risk. Please contact authorized Vishay personnel to obtain written terms and conditions regarding products designed for such applications.

No license, express or implied, by estoppel or otherwise, to any intellectual property rights is granted by this document or by any conduct of Vishay. Product names and markings noted herein may be trademarks of their respective owners.

## Material Category Policy

**Vishay Intertechnology, Inc. hereby certifies that all its products that are identified as RoHS-Compliant fulfill the definitions and restrictions defined under Directive 2011/65/EU of The European Parliament and of the Council of June 8, 2011 on the restriction of the use of certain hazardous substances in electrical and electronic equipment (EEE) - recast, unless otherwise specified as non-compliant.**

**Please note that some Vishay documentation may still make reference to RoHS Directive 2002/95/EC. We confirm that all the products identified as being compliant to Directive 2002/95/EC conform to Directive 2011/65/EU.**

**Vishay Intertechnology, Inc. hereby certifies that all its products that are identified as Halogen-Free follow Halogen-Free requirements as per JEDEC JS709A standards. Please note that some Vishay documentation may still make reference to the IEC 61249-2-21 definition. We confirm that all the products identified as being compliant to IEC 61249-2-21 conform to JEDEC JS709A standards.**



Компания «ЭлектроПласт» предлагает заключение долгосрочных отношений при поставках импортных электронных компонентов на взаимовыгодных условиях!

Наши преимущества:

- Оперативные поставки широкого спектра электронных компонентов отечественного и импортного производства напрямую от производителей и с крупнейших мировых складов;
- Поставка более 17-ти миллионов наименований электронных компонентов;
- Поставка сложных, дефицитных, либо снятых с производства позиций;
- Оперативные сроки поставки под заказ (от 5 рабочих дней);
- Экспресс доставка в любую точку России;
- Техническая поддержка проекта, помощь в подборе аналогов, поставка прототипов;
- Система менеджмента качества сертифицирована по Международному стандарту ISO 9001;
- Лицензия ФСБ на осуществление работ с использованием сведений, составляющих государственную тайну;
- Поставка специализированных компонентов (Xilinx, Altera, Analog Devices, Intersil, Interpoint, Microsemi, Aeroflex, Peregrine, Syfer, Eurofarad, Texas Instrument, Miteq, Cobham, E2V, MA-COM, Hittite, Mini-Circuits, General Dynamics и др.);

Помимо этого, одним из направлений компании «ЭлектроПласт» является направление «Источники питания». Мы предлагаем Вам помощь Конструкторского отдела:

- Подбор оптимального решения, техническое обоснование при выборе компонента;
- Подбор аналогов;
- Консультации по применению компонента;
- Поставка образцов и прототипов;
- Техническая поддержка проекта;
- Защита от снятия компонента с производства.



#### Как с нами связаться

**Телефон:** 8 (812) 309 58 32 (многоканальный)

**Факс:** 8 (812) 320-02-42

**Электронная почта:** [org@eplast1.ru](mailto:org@eplast1.ru)

**Адрес:** 198099, г. Санкт-Петербург, ул. Калинина, дом 2, корпус 4, литера А.