

HIT CONNECTOR

Board-to-wire

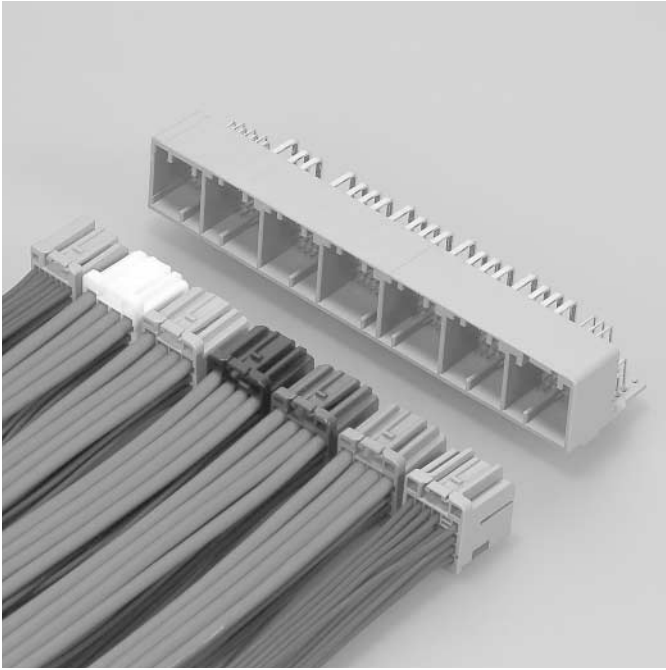

The HIT connector is multi-circuit and miniaturized for ECU for the automobile.
Female connector is divided into seven housings, and considers the ergonomics and workability.

Features

●Multi-circuit structure, Miniaturized

Current products available are up to 180-circuit. Although this connector is multi-circuit, it was miniaturized by narrow pitch. The insertion force in the mating operation of one time is decreased by block division structure.

●Reliability

It conforms to the automotive performance evaluation standard.

●Diversity

It is hybrid structures of using 0.64 mm and 2.8 mm terminals. Large current circuit is also available.

Specifications

- Current rating: 0.64 Terminal/ 5 A AC, DC (0.5 mm², Single circuit)
2.8 Terminal/ 25 A AC, DC (5 mm², Single circuit)
- Voltage rating: 14 V AC, DC
- Temperature range: -40°C to +100°C
(including temperature rise in applying electrical current)
- Contact resistance: 0.64 Terminal;
Initial value/ 20 mΩ max.
After environmental tests/ 20 mΩ max.
2.8 Terminal;
Initial value/ 5 mΩ max.
After environmental tests/ 5 mΩ max.
- Insulation resistance: 20 MΩ min.
- Withstanding voltage: 1,000 VAC/minute
- Applicable wire: TXL/ AVSS/ CAVS
0.64 Terminal S/M; 0.3 mm² to 0.85 mm²
2.8 Terminal S/M/L; 0.85 mm² to 5.0 mm²

- * Compliant with ELV/RoHS.
- * Contact JST for details.

Female terminal

● 0.64 Female terminal SSS/SS

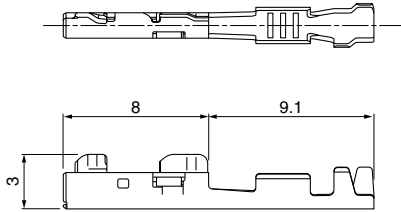

● 0.64 Female terminal S/M

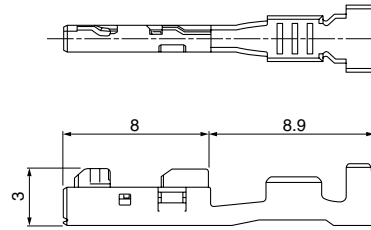

● 2.8 Female terminal S/M/L

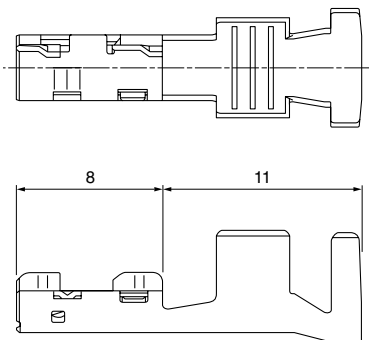

Terminal	Model No.	Applicable wire range		Q ty/reel
		Conductor (mm ²)	Insulation O.D. (mm)	
*0.64 SSS	SNAC3-A001T-M0.64	0.13	0.85	6,000
*0.64 SS	SNAC3-A011T-M0.64	0.22 to 0.35	0.95 to 1.10	5,000
0.64 S	SNAC3-A021T-M0.64	0.3 to 0.5	1.4 to 1.8	5,000
0.64 M	SNAC3-A031T-M0.64	0.5 to 0.85	1.8 to 2.0	5,000
2.8 S	SNAC-A061T-M2.8	0.85 to 1.3	2.0 to 2.3	3,000
2.8 M	SNAC-A081T-M2.8	2.0 to 3.3	2.6 to 3.2	2,500
2.8 L	SNAC-A091T-M2.8	3.0 to 5.0	3.2 to 4.0	2,000

Material and Finish

Copper alloy, tin-plated (reflow treatment)

Note: *Please contact JST about the use of these parts.

Female connector

● A Block

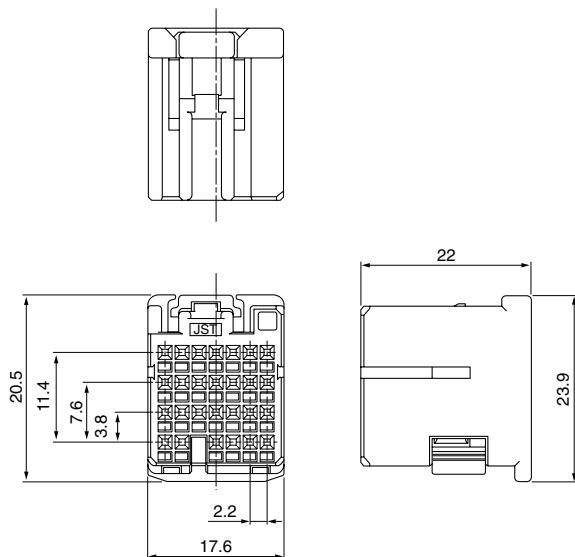

● B Block

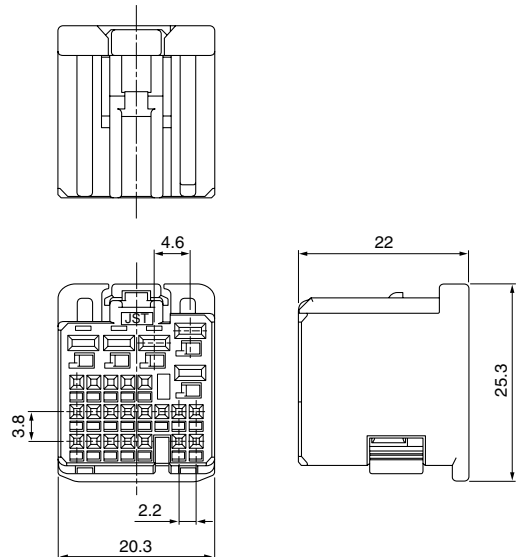

HIT CONNECTOR

Female connector

• C Block

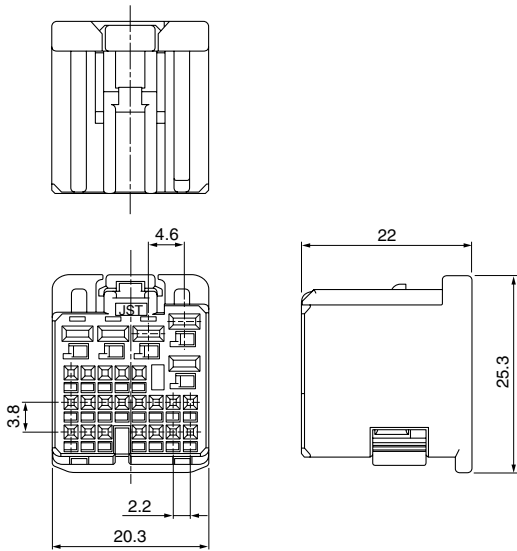

• D Block

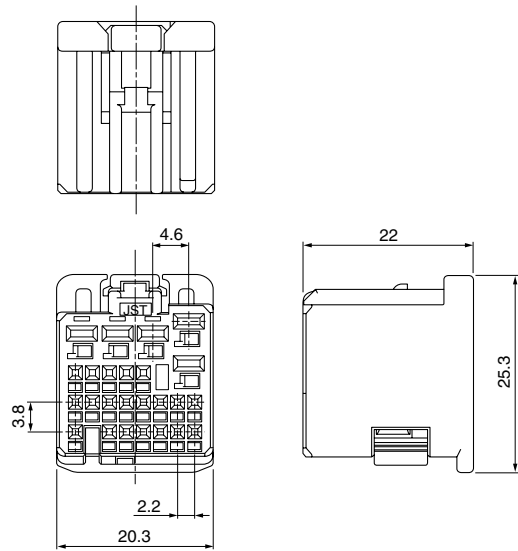

• E Block

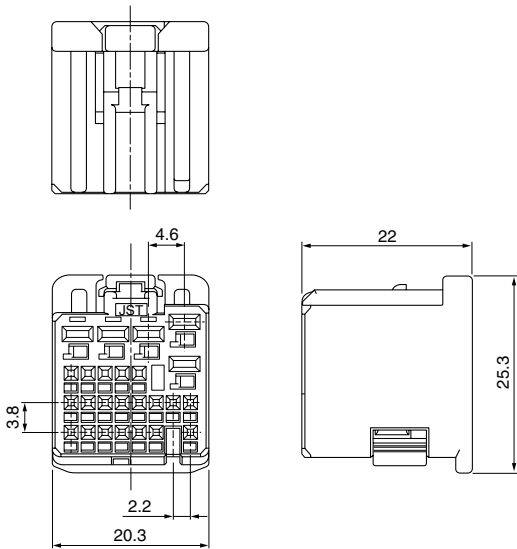

• F Block

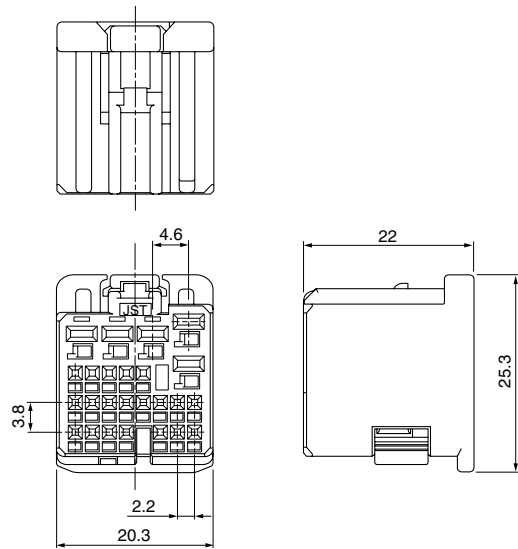

• G Block

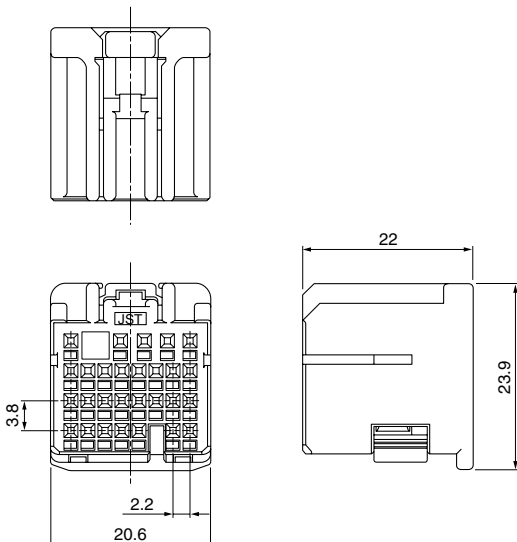

Type	Circuits	Model No.	Q'ty/box	Color	
				Housing	Retainer
A Block	27	HITPB-27-A-LM	336	Light green	Blue
B Block	25	HITPB-25-B-S	280	Natural (White)	Blue
C Block		HITPB-25-C-LE	280	Light blue	Blue
D Block		HITPB-25-D-K	280	Black	Blue
E Block		HITPB-25-E-N	280	Brown	Blue
F Block		HITPB-25-F-PK	280	Pink	Blue
G Block	28	HITPB-28-G-H	280	Gray	Blue

Material

Housing: PBT
Retainer: PBT

Note: Contact JST for other circuits.

Header

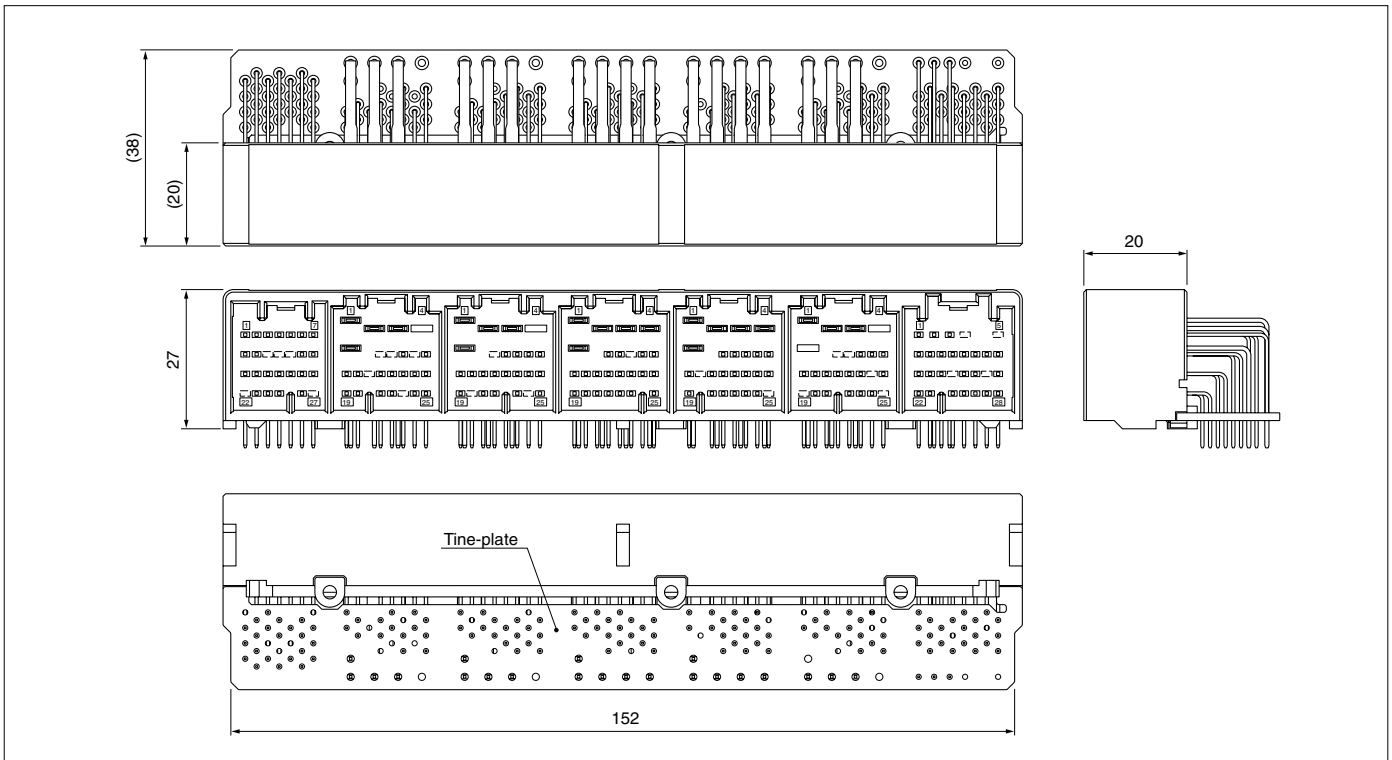

Circuits	Model No.	Q'ty/box
151	S151B-HITHTP-01A	105

Material and Finish

Housing: Glass-filled PBT
 Tine-plate: Glass-filled PBT
 Signal pin: Brass, nickel-undercoated, tin-plated (reflow treatment)
 Power pin: Copper alloy, nickel-undercoated, tin-plated (reflow treatment)

PC board layout

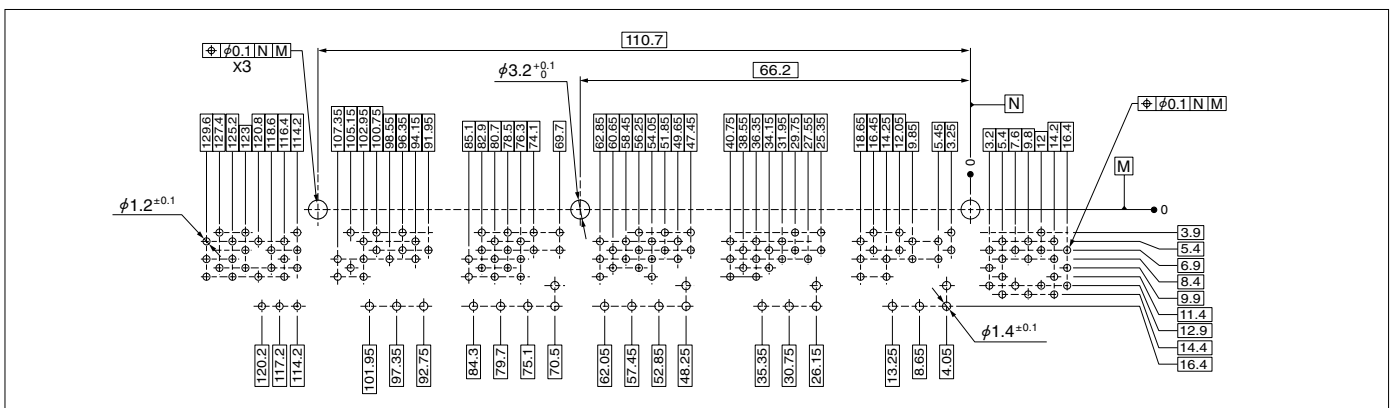

Crimping machine, Applicator, Hand crimp tool

Strip terminal	Crimping machine	Crimp applicator MKS-L		Hand crimp tool
		Dies	Crimp applicator with dies	
SNAC3-A001T-M0.64	AP-K2N	MK/SNAC3-A001-064	APLMK SNAC3-A001-064	—
SNAC3-A011T-M0.64		MK/SNAC3-A011-064	APLMK SNAC3-A011-064	—
SNAC3-A021T-M0.64		MK/SNAC3-A021-064	APLMK SNAC3-A021-064	YRK-1003
SNAC3-A031T-M0.64		MK/SNAC3-A031-064	APLMK SNAC3-A031-064	YRK-1012
SNAC-A061T-M2.8		MK/SNAC-A061-28	APLMK SNAC-A061-28	—
SNAC-A081T-M2.8		MK/SNAC-A081-28	APLMK SNAC-A081-28	—
SNAC-A091T-M2.8		MK/SNAC-A091-28	APLMK SNAC-A091-28	—

Note: When crimping operation is conducted using an applicator and die set other than the above, JST cannot guarantee the performance of the terminal.

Mouser Electronics

Authorized Distributor

Click to View Pricing, Inventory, Delivery & Lifecycle Information:

JST:

[SNAC-A091T-M2.8](#) [SNAC3-A001T-M0.64](#) [SNAC3-A031T-M0.64](#) [SNAC-A061T-M2.8](#) [SNAC-A081T-M2.8](#) [SNAC3-A021T-M0.64](#)



Компания «ЭлектроПласт» предлагает заключение долгосрочных отношений при поставках импортных электронных компонентов на взаимовыгодных условиях!

Наши преимущества:

- Оперативные поставки широкого спектра электронных компонентов отечественного и импортного производства напрямую от производителей и с крупнейших мировых складов;
- Поставка более 17-ти миллионов наименований электронных компонентов;
- Поставка сложных, дефицитных, либо снятых с производства позиций;
- Оперативные сроки поставки под заказ (от 5 рабочих дней);
- Экспресс доставка в любую точку России;
- Техническая поддержка проекта, помощь в подборе аналогов, поставка прототипов;
- Система менеджмента качества сертифицирована по Международному стандарту ISO 9001;
- Лицензия ФСБ на осуществление работ с использованием сведений, составляющих государственную тайну;
- Поставка специализированных компонентов (Xilinx, Altera, Analog Devices, Intersil, Interpoint, Microsemi, Aeroflex, Peregrine, Syfer, Eurofarad, Texas Instrument, Miteq, Cobham, E2V, MA-COM, Hittite, Mini-Circuits, General Dynamics и др.);

Помимо этого, одним из направлений компании «ЭлектроПласт» является направление «Источники питания». Мы предлагаем Вам помощь Конструкторского отдела:

- Подбор оптимального решения, техническое обоснование при выборе компонента;
- Подбор аналогов;
- Консультации по применению компонента;
- Поставка образцов и прототипов;
- Техническая поддержка проекта;
- Защита от снятия компонента с производства.



Как с нами связаться

Телефон: 8 (812) 309 58 32 (многоканальный)

Факс: 8 (812) 320-02-42

Электронная почта: org@eplast1.ru

Адрес: 198099, г. Санкт-Петербург, ул. Калинина, дом 2, корпус 4, литера А.