

74AHC594-Q100; 74AHCT594-Q100

8-bit shift register with output register

Rev. 3 — 25 June 2020

Product data sheet

1. General description

The 74AHC594-Q100; 74AHCT594-Q100 is a high-speed Si-gate CMOS device and is pin compatible with Low-Power Schottky TTL (LSTTL). It is specified in compliance with JEDEC standard No. 7-A.

The 74AHC594-Q100; 74AHCT594-Q100 is an 8-bit, non-inverting, serial-in, parallel-out shift register that feeds an 8-bit D-type storage register. Separate clocks (SHCP and STCP) and direct overriding clears (SHR and STR) are provided on both the shift and storage registers. A serial output (Q7S) is provided for cascading purposes.

Both the shift and storage register clocks are positive-edge triggered. If the user wishes to connect both clocks together, the shift register will always be one count pulse ahead of the storage register.

This product has been qualified to the Automotive Electronics Council (AEC) standard Q100 (Grade 1) and is suitable for use in automotive applications.

2. Features and benefits

- Automotive product qualification in accordance with AEC-Q100 (Grade 1)
 - Specified from -40 °C to +85 °C and from -40 °C to +125 °C
- Wide supply voltage range from 2.0 V to 5.5 V
- Balanced propagation delays
- All inputs have Schmitt-trigger action
- Overvoltage tolerant inputs to 5.5 V
- High noise immunity
- CMOS low power dissipation
- 8-bit serial-in, parallel-out shift register with storage
- Independent direct overriding clears on shift and storage registers
- Independent clocks for shift and storage registers
- Latch-up performance exceeds 100 mA per JESD 78 Class II Level A
- Input levels:
 - For 74AHC594-Q100: CMOS level
 - For 74AHCT594-Q100: TTL level
- ESD protection:
 - MIL-STD-883, method 3015 exceeds 2000 V
 - HBM JESD22-A114F exceeds 2000 V
 - MM JESD22-A115-A exceeds 200 V (C = 200 pf, R = 0 Ω)
- Multiple package options
- DHVQFN package with Side-Wettable Flanks enabling Automatic Optical Inspection (AOI) of solder joints

3. Applications

- Serial-to parallel data conversion
- Remote control holding register

4. Ordering information

Table 1. Ordering information

Type number	Package			Version
	Temperature range	Name	Description	
74AHC594D-Q100	-40 °C to +125 °C	SO16	plastic small outline package; 16 leads; body width 3.9 mm	SOT109-1
74AHCT594D-Q100				
74AHCT594DB-Q100	-40 °C to +125 °C	SSOP16	plastic shrink small outline package; 16 leads; body width 5.3 mm	SOT338-1
74AHC594PW-Q100	-40 °C to +125 °C	TSSOP16	plastic thin shrink small outline package; 16 leads; body width 4.4 mm	SOT403-1
74AHCT594PW-Q100				
74AHC594BQ-Q100	-40 °C to +125 °C	DHVQFN16	plastic dual in-line compatible thermal enhanced very thin quad flat package; no leads; 16 terminals; body 2.5 × 3.5 × 0.85 mm	SOT763-1
74AHCT594BQ-Q100				

5. Functional diagram



Fig. 1. Functional diagram



Fig. 2. Logic symbol

Fig. 3. IEC logic symbol

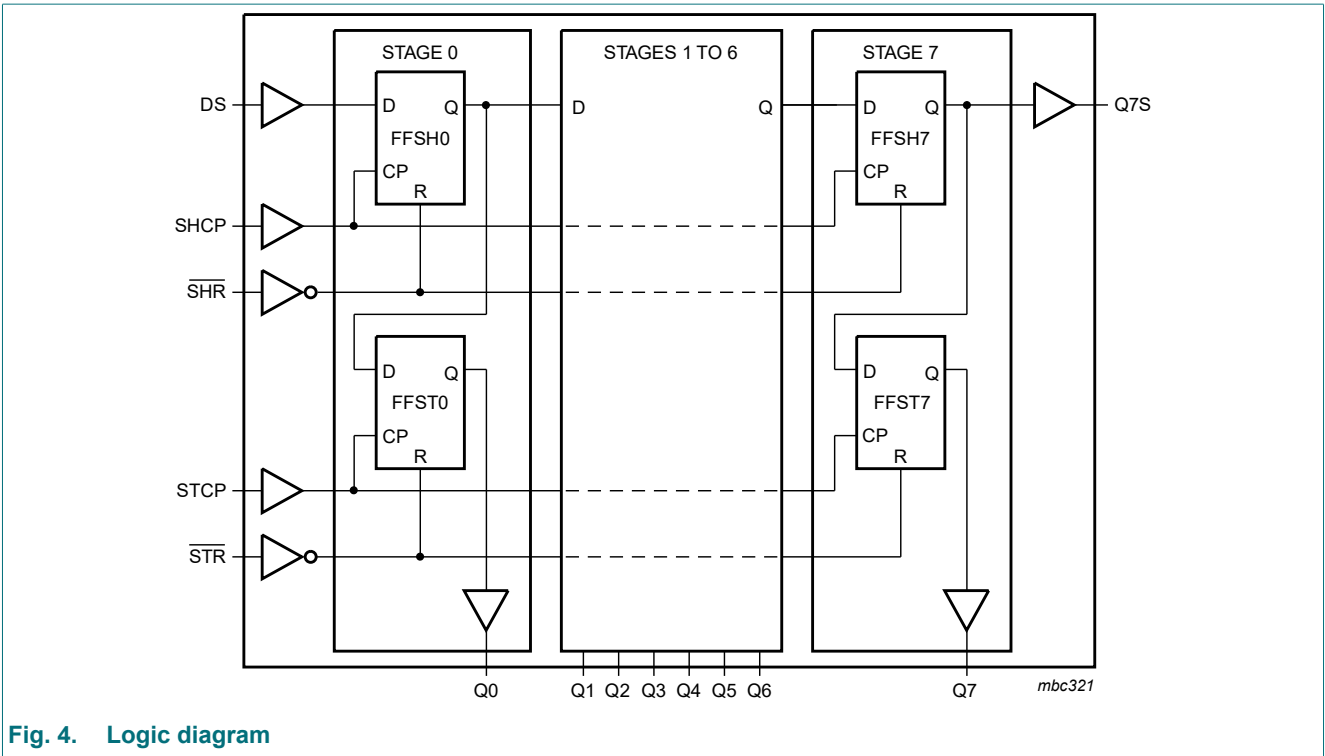

Fig. 4. Logic diagram

6. Pinning information

6.1. Pinning

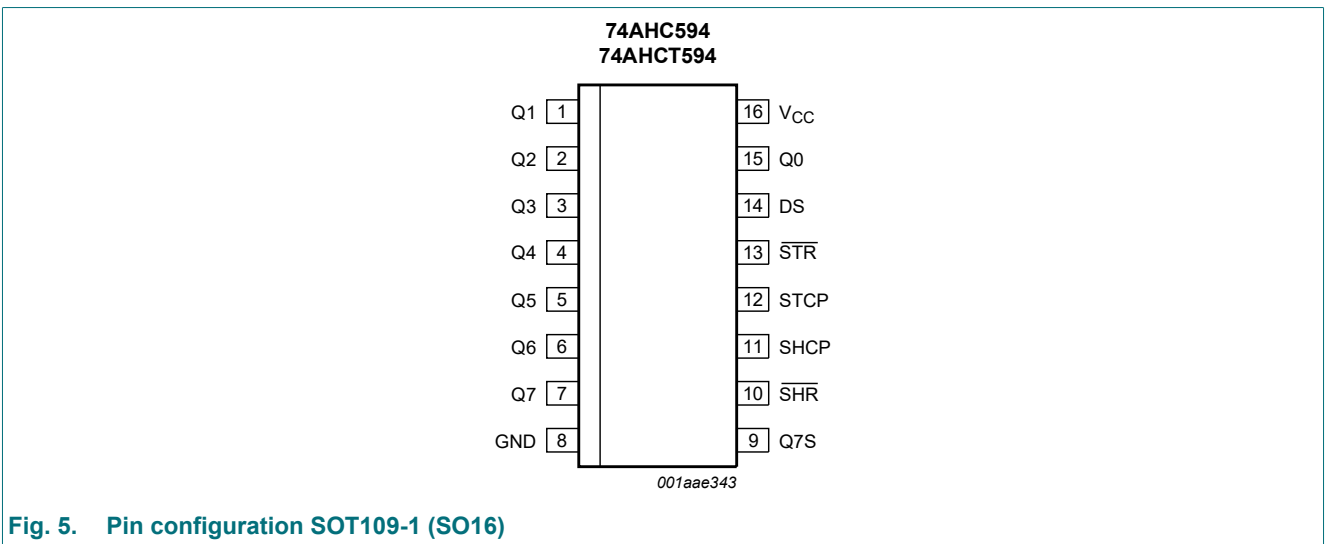

Fig. 5. Pin configuration SOT109-1 (SO16)

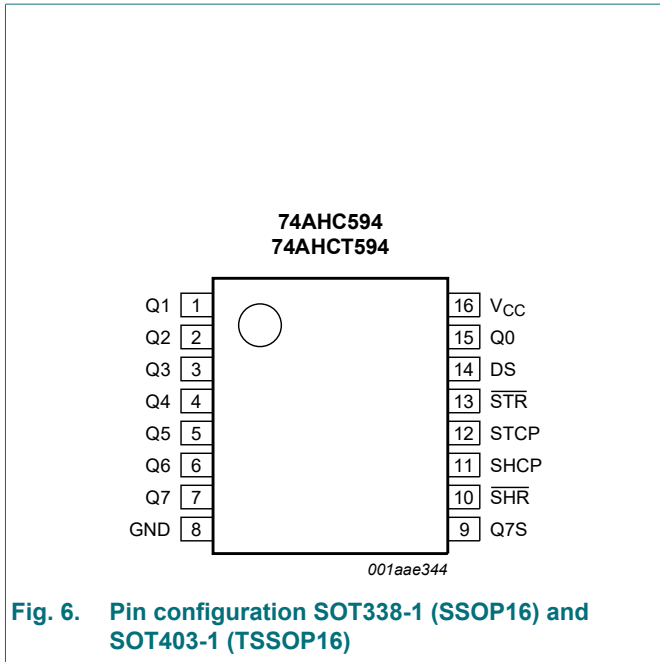

Fig. 6. Pin configuration SOT338-1 (SSOP16) and SOT403-1 (TSSOP16)



Fig. 7. Pin configuration SOT763-1 (DHVQFN16)

6.2. Pin description

Table 2. Pin description

Symbol	Pin	Description
Q0, Q1, Q2, Q3, Q4, Q5, Q6, Q7	15, 1, 2, 3, 4, 5, 6, 7	parallel data output
GND	8	ground (0 V)
Q7S	9	serial data output
SHR	10	shift register reset input (active LOW)
SHCP	11	shift register clock input
STCP	12	storage register clock input
STR	13	storage register reset input (active LOW)
DS	14	serial data input
V _{CC}	16	supply voltage

7. Functional description

Table 3. Function table

H = HIGH voltage state; L = LOW voltage state; ↑ = LOW to HIGH transition; X = don't care; NC = no change.

Input					Output		Function
SHCP	STCP	SHR	STR	DS	Q7S	Qn	
X	X	L	X	X	L	NC	a LOW-state on $\overline{\text{SHR}}$ only affects the shift register
X	X	X	L	X	NC	L	a LOW-state on $\overline{\text{STR}}$ only affects the storage register
X	↑	L	H	X	L	L	empty shift register loaded into storage register
↑	X	H	X	H	Q6S	NC	logic HIGH level shifted into shift register stage 0. Contents of all shift register stages shifted through, e.g. previous state of stage 6 (internal Q6S) appears on the serial output (Q7S).
X	↑	H	H	X	NC	QnS	contents of shift register stages (internal QnS) are transferred to the storage register and parallel output stages
↑	↑	H	H	X	Q6S	QnS	contents of shift register shifted through; previous contents of the shift register is transferred to the storage register and the parallel output stages

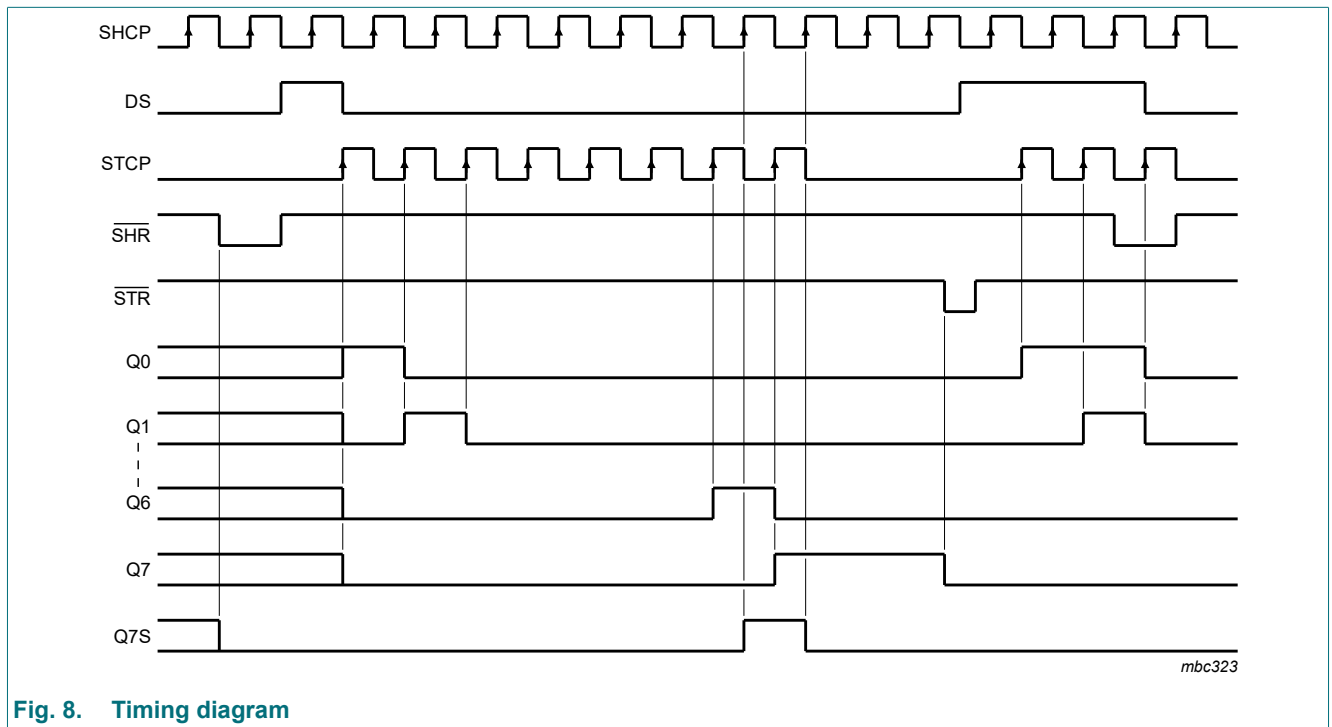

Fig. 8. Timing diagram

8. Limiting values

Table 4. Limiting values

In accordance with the Absolute Maximum Rating System (IEC 60134). Voltages are referenced to GND (ground = 0 V).

Symbol	Parameter	Conditions	Min	Max	Unit
V_{CC}	supply voltage		-0.5	+7.0	V
V_I	input voltage		-0.5	+7.0	V
I_{IK}	input clamping current	$V_I < -0.5$ V [1]	-20	-	mA
I_{OK}	output clamping current	$V_O < -0.5$ V or $V_O > V_{CC} + 0.5$ V [1]	-20	+20	mA
I_O	output current	$V_O = -0.5$ V to $(V_{CC} + 0.5$ V)	-25	+25	mA
I_{CC}	supply current		-	+75	mA
I_{GND}	ground current		-75	-	mA
T_{stg}	storage temperature		-65	+150	°C
P_{tot}	total power dissipation	$T_{amb} = -40$ °C to +125 °C [2]	-	500	mW

[1] The input and output voltage ratings may be exceeded if the input and output current ratings are observed.

[2] For SOT109-1 (SO16) package: P_{tot} derates linearly with 12.4 mW/K above 110 °C.

For SOT338-1 (SSOP16) package: P_{tot} derates linearly with 8.5 mW/K above 91 °C.

For SOT403-1 (TSSOP16) package: P_{tot} derates linearly with 8.5 mW/K above 91 °C.

For SOT763-1 (DHVQFN16) package: P_{tot} derates linearly with 11.2 mW/K above 106 °C.

9. Recommended operating conditions

Table 5. Operating conditions

Symbol	Parameter	Conditions	74AHC594-Q100			74AHCT594-Q100			Unit
			Min	Typ	Max	Min	Typ	Max	
V_{CC}	supply voltage		2.0	5.0	5.5	4.5	5.0	5.5	V
V_I	input voltage		0	-	5.5	0	-	5.5	V
V_O	output voltage		0	-	V_{CC}	0	-	V_{CC}	V
T_{amb}	ambient temperature		-40	+25	+125	-40	+25	+125	°C
$\Delta t/\Delta V$	input transition rise and fall rate	$V_{CC} = 3.0$ V to 3.6 V	-	-	100	-	-	-	ns/V
		$V_{CC} = 4.5$ V to 5.5 V	-	-	20	-	-	20	ns/V

10. Static characteristics

Table 6. Static characteristics

At recommended operating conditions; voltages are referenced to GND (ground = 0 V).

Symbol	Parameter	Conditions	25 °C			-40 °C to +85 °C		-40 °C to +125 °C		Unit
			Min	Typ	Max	Min	Max	Min	Max	
74AHC594-Q100										
V _{IH}	HIGH-level input voltage	V _{CC} = 2.0 V	1.5	-	-	1.5	-	1.5	-	V
		V _{CC} = 3.0 V	2.1	-	-	2.1	-	2.1	-	V
		V _{CC} = 5.5 V	3.85	-	-	3.85	-	3.85	-	V
V _{IL}	LOW-level input voltage	V _{CC} = 2.0 V	-	-	0.5	-	0.5	-	0.5	V
		V _{CC} = 3.0 V	-	-	0.9	-	0.9	-	0.9	V
		V _{CC} = 5.5 V	-	-	1.65	-	1.65	-	1.65	V
V _{OH}	HIGH-level output voltage	V _I = V _{IH} or V _{IL}								
		I _O = -50 μA; V _{CC} = 2.0 V	1.9	2.0	-	1.9	-	1.9	-	V
		I _O = -50 μA; V _{CC} = 3.0 V	2.9	3.0	-	2.9	-	2.9	-	V
		I _O = -50 μA; V _{CC} = 4.5 V	4.4	4.5	-	4.4	-	4.4	-	V
		I _O = -4.0 mA; V _{CC} = 3.0 V	2.58	-	-	2.48	-	2.40	-	V
V _{OL}	LOW-level output voltage	V _I = V _{IH} or V _{IL}								
		I _O = 50 μA; V _{CC} = 2.0 V	-	0	0.1	-	0.1	-	0.1	V
		I _O = 50 μA; V _{CC} = 3.0 V	-	0	0.1	-	0.1	-	0.1	V
		I _O = 50 μA; V _{CC} = 4.5 V	-	0	0.1	-	0.1	-	0.1	V
		I _O = 4 mA; V _{CC} = 3.0 V	-	-	0.36	-	0.44	-	0.55	V
I _I	input leakage current	V _I = 5.5 V or GND; V _{CC} = 0 V to 5.5 V	-	-	0.1	-	1.0	-	2.0	μA
		V _I = V _{CC} or GND; I _O = 0 A; V _{CC} = 5.5 V	-	-	4.0	-	40	-	80	μA
C _I	input capacitance	V _I = V _{CC} or GND	-	3	10	-	10	-	10	pF

Symbol	Parameter	Conditions	25 °C			-40 °C to +85 °C		-40 °C to +125 °C		Unit
			Min	Typ	Max	Min	Max	Min	Max	
74AHCT594-Q100										
V _{IH}	HIGH-level input voltage	V _{CC} = 4.5 V to 5.5 V	2.0	-	-	2.0	-	2.0	-	V
V _{IL}	LOW-level input voltage	V _{CC} = 4.5 V to 5.5 V	-	-	0.8	-	0.8	-	0.8	V
V _{OH}	HIGH-level output voltage	V _I = V _{IH} or V _{IL}								
		I _O = -50 µA; V _{CC} = 4.5 V	4.4	4.5	-	4.4	-	4.4	-	V
		I _O = -8.0 mA; V _{CC} = 4.5 V	3.94	-	-	3.80	-	3.70	-	V
V _{OL}	LOW-level output voltage	V _I = V _{IH} or V _{IL}								
		I _O = 50 µA; V _{CC} = 4.5 V	-	0	0.1	-	0.1	-	0.1	V
		I _O = 8 mA; V _{CC} = 4.5 V	-	-	0.36	-	0.44	-	0.55	V
I _I	input leakage current	V _I = 5.5 V or GND; V _{CC} = 0 V to 5.5 V	-	-	0.1	-	1.0	-	2.0	µA
I _{CC}	supply current	V _I = V _{CC} or GND; I _O = 0 A; V _{CC} = 5.5 V	-	-	4.0	-	40	-	80	µA
ΔI _{CC}	additional supply current	per input pin; V _I = V _{CC} - 2.1 V; other pins at V _{CC} or GND; I _O = 0 A; V _{CC} = 4.5 V to 5.5 V	-	-	1.35	-	1.5	-	1.5	mA
C _I	input capacitance	V _I = V _{CC} or GND	-	3	10	-	10	-	10	pF

11. Dynamic characteristics

Table 7. Dynamic characteristics

Voltages are referenced to GND (ground = 0 V); for test circuit see Fig. 15.

Symbol	Parameter	Conditions	25 °C			-40 °C to +85 °C		-40 °C to +125 °C		Unit
			Min	Typ[1]	Max	Min	Max	Min	Max	
74AHC594-Q100										
t _{PLH}	LOW to HIGH propagation delay	SHCP to Q7S; see Fig. 9								
		V _{CC} = 3.0 V to 3.6 V								
		C _L = 15 pF	-	5.2	8.5	2.2	9.7	2.2	10.6	ns
		C _L = 50 pF	-	7.4	11.5	3.0	13.2	3.0	14.3	ns
		V _{CC} = 4.5 V to 5.5 V								
		C _L = 15 pF	-	3.8	6.3	1.7	7.2	1.7	7.8	ns
		C _L = 50 pF	-	4.8	8.0	2.4	9.1	2.4	10.0	ns
		STCP to Qn; see Fig. 10								
		V _{CC} = 3.0 V to 3.6 V								
		C _L = 15 pF	-	5.1	8.3	2.3	9.5	2.3	10.6	ns
		C _L = 50 pF	-	7.3	11.9	3.3	13.6	3.3	14.7	ns
		V _{CC} = 4.5 V to 5.5 V								
C _L = 15 pF	-	3.5	5.7	1.8	6.5	1.8	7.1	ns		
C _L = 50 pF	-	4.8	7.8	2.6	9.0	2.6	9.8	ns		

Symbol	Parameter	Conditions	25 °C			-40 °C to +85 °C		-40 °C to +125 °C		Unit
			Min	Typ[1]	Max	Min	Max	Min	Max	
t _{PHL}	HIGH to LOW propagation delay	SHCP to Q7S; see Fig. 9								
		V _{CC} = 3.0 V to 3.6 V								
		C _L = 15 pF	-	5.5	8.9	2.3	10.2	2.3	11.0	ns
		C _L = 50 pF	-	7.4	12.1	3.0	13.9	3.0	15.1	ns
		V _{CC} = 4.5 V to 5.5 V								
		C _L = 15 pF	-	4.1	6.7	1.9	7.6	1.9	8.2	ns
		C _L = 50 pF	-	5.4	8.8	2.5	10.1	2.5	11.0	ns
		STCP to Qn; see Fig. 10								
		V _{CC} = 3.0 V to 3.6 V								
		C _L = 15 pF	-	5.5	9.1	2.4	10.4	2.4	11.3	ns
		C _L = 50 pF	-	7.3	12.0	3.2	13.8	3.2	15.0	ns
		V _{CC} = 4.5 V to 5.5 V								
		C _L = 15 pF	-	3.7	6.0	1.9	6.9	1.9	7.5	ns
		C _L = 50 pF	-	5.2	8.5	2.6	9.7	2.6	10.5	ns
		SHR to Q7S; see Fig. 13								
		V _{CC} = 3.0 V to 3.6 V								
		C _L = 15 pF	-	5.7	9.5	2.3	10.8	2.3	11.7	ns
		C _L = 50 pF	-	7.5	12.2	3.6	14.0	3.6	15.2	ns
		V _{CC} = 4.5 V to 5.5 V								
		C _L = 15 pF	-	4.1	6.7	2.0	7.6	2.0	8.2	ns
C _L = 50 pF	-	5.4	8.8	2.8	10.1	2.8	11.0	ns		
STR to Qn; see Fig. 12										
V _{CC} = 3.0 V to 3.6 V										
C _L = 15 pF	-	5.8	9.6	2.8	11.0	2.8	12.0	ns		
C _L = 50 pF	-	7.7	12.5	3.8	14.4	3.8	15.6	ns		
V _{CC} = 4.5 V to 5.5 V										
C _L = 15 pF	-	4.1	7.2	2.2	8.2	2.2	8.9	ns		
C _L = 50 pF	-	5.4	9.4	3.0	10.7	3.0	11.6	ns		
f _{max}	maximum frequency	SHCP or STCP; see Fig. 9 and Fig. 10								
		V _{CC} = 3.0 V to 3.6 V	80	125	-	70	-	65	-	MHz
		V _{CC} = 4.5 V to 5.5 V	90	170	-	80	-	70	-	MHz
t _w	pulse width	SHCP and STCP HIGH or LOW; see Fig. 9 and Fig. 10								
		V _{CC} = 3.0 V to 3.6 V	6.0	-	-	6.5	-	7.0	-	ns
		V _{CC} = 4.5 V to 5.5 V	5.5	-	-	6.0	-	6.5	-	ns
		SHR and STR HIGH or LOW; see Fig. 13 and Fig. 12								
		V _{CC} = 3.0 V to 3.6 V	5.0	-	-	5.0	-	5.5	-	ns
V _{CC} = 4.5 V to 5.5 V	5.0	-	-	5.2	-	5.7	-	ns		

Symbol	Parameter	Conditions	25 °C			-40 °C to +85 °C		-40 °C to +125 °C		Unit
			Min	Typ[1]	Max	Min	Max	Min	Max	
t _{su}	set-up time	DS to SHCP; see Fig. 11								
		V _{CC} = 3.0 V to 3.6 V	3.5	-	-	3.5	-	4.0	-	ns
		V _{CC} = 4.5 V to 5.5 V	3.0	-	-	3.0	-	3.5	-	ns
		SHR to STCP; see Fig. 14								
		V _{CC} = 3.0 V to 3.6 V	8.0	-	-	9.0	-	9.5	-	ns
		V _{CC} = 4.5 V to 5.5 V	5.0	-	-	5.0	-	5.5	-	ns
		SHCP to STCP; see Fig. 10								
		V _{CC} = 3.0 V to 3.6 V	8.0	-	-	8.5	-	9.0	-	ns
V _{CC} = 4.5 V to 5.5 V	5.0	-	-	5.0	-	5.5	-	ns		
t _h	hold time	DS to SHCP; see Fig. 11								
		V _{CC} = 3.0 V to 3.6 V	1.5	-	-	1.5	-	2.0	-	ns
		V _{CC} = 4.5 V to 5.5 V	2.0	-	-	2.0	-	2.5	-	ns
t _{rec}	recovery time	SHR to SHCP; see Fig. 13								
		V _{CC} = 3.0 V to 3.6 V	4.2	-	-	4.8	-	5.3	-	ns
		V _{CC} = 4.5 V to 5.5 V	2.9	-	-	3.3	-	3.8	-	ns
		STR to STCP; see Fig. 12								
		V _{CC} = 3.0 V to 3.6 V	4.6	-	-	5.3	-	5.8	-	ns
V _{CC} = 4.5 V to 5.5 V	3.2	-	-	3.7	-	4.3	-	ns		
C _{PD}	power dissipation capacitance	f _i = 1 MHz; V _I = GND to V _{CC} [2]	-	55	-	-	-	-	-	pF
74AHCT594-Q100; V_{CC} = 4.5 V to 5.5 V										
t _{PLH}	LOW to HIGH propagation delay	SHCP to Q7S; see Fig. 9								
		C _L = 15 pF	-	3.8	6.3	1.7	7.2	1.7	7.8	ns
		C _L = 50 pF	-	4.8	8.0	2.2	9.1	2.2	9.9	ns
		STCP to Qn; see Fig. 10								
		C _L = 15 pF	-	3.5	5.7	1.8	6.5	1.8	7.1	ns
C _L = 50 pF	-	4.6	7.7	2.6	8.8	2.6	9.6	ns		
t _{PHL}	HIGH to LOW propagation delay	SHCP to Q7S; see Fig. 9								
		C _L = 15 pF	-	4.1	6.7	1.8	7.6	1.8	8.3	ns
		C _L = 50 pF	-	5.4	8.8	2.4	10.1	2.4	11.0	ns
		STCP to Qn; see Fig. 10								
		C _L = 15 pF	-	3.7	6.1	1.9	6.9	1.9	7.2	ns
		C _L = 50 pF	-	5.2	8.5	2.6	9.7	2.6	10.5	ns
		SHR to Q7S; see Fig. 13								
		C _L = 15 pF	-	4.3	7.0	2.4	8.0	2.4	8.7	ns
		C _L = 50 pF	-	5.4	8.8	2.7	10.1	2.7	11.0	ns
STR to Qn; see Fig. 12										
C _L = 15 pF	-	4.5	7.4	2.3	8.4	2.3	9.2	ns		
C _L = 50 pF	-	5.7	9.4	3.1	10.7	3.1	11.7	ns		
f _{max}	maximum frequency	SHCP or STCP; see Fig. 9 and Fig. 10	90	160	-	80	-	70	-	MHz

Symbol	Parameter	Conditions	25 °C			-40 °C to +85 °C		-40 °C to +125 °C		Unit
			Min	Typ[1]	Max	Min	Max	Min	Max	
t _W	pulse width	SHCP and STCP HIGH or LOW; see Fig. 9 and Fig. 10	5.5	-	-	6.0	-	6.5	-	ns
		SHR and STR HIGH or LOW; see Fig. 13 and Fig. 12	5.2	-	-	5.5	-	6.0	-	ns
t _{su}	set-up time	DS to SHCP; see Fig. 11	3.0	-	-	3.0	-	3.5	-	ns
		SHR to STCP; see Fig. 14	5.0	-	-	5.0	-	5.5	-	ns
		SHCP to STCP; see Fig. 10	5.0	-	-	5.0	-	5.5	-	ns
t _h	hold time	DS to SHCP; see Fig. 11	2.0	-	-	2.0	-	2.5	-	ns
t _{rec}	recovery time	SHR to SHCP; see Fig. 13	2.9	-	-	3.3	-	3.8	-	ns
		STR to STCP; see Fig. 12	3.4	-	-	3.8	-	4.3	-	ns
C _{PD}	power dissipation capacitance	f _i = 1 MHz; V _I = GND to V _{CC} [2]	-	55	-	-	-	-	-	pF

- [1] Typical values are measured at nominal supply voltage (V_{CC} = 3.3 V and V_{CC} = 5.0 V).
- [2] C_{PD} is used to determine the dynamic power dissipation (P_D in μW).
 $P_D = C_{PD} \times V_{CC}^2 \times f_i \times N + \sum(C_L \times V_{CC}^2 \times f_o)$ where:
 f_i = input frequency in MHz;
 f_o = output frequency in MHz;
 C_L = output load capacitance in pF;
 V_{CC} = supply voltage in V;
 N = number of inputs switching;
 $\sum(C_L \times V_{CC}^2 \times f_o)$ = sum of the outputs.

11.1. Waveforms

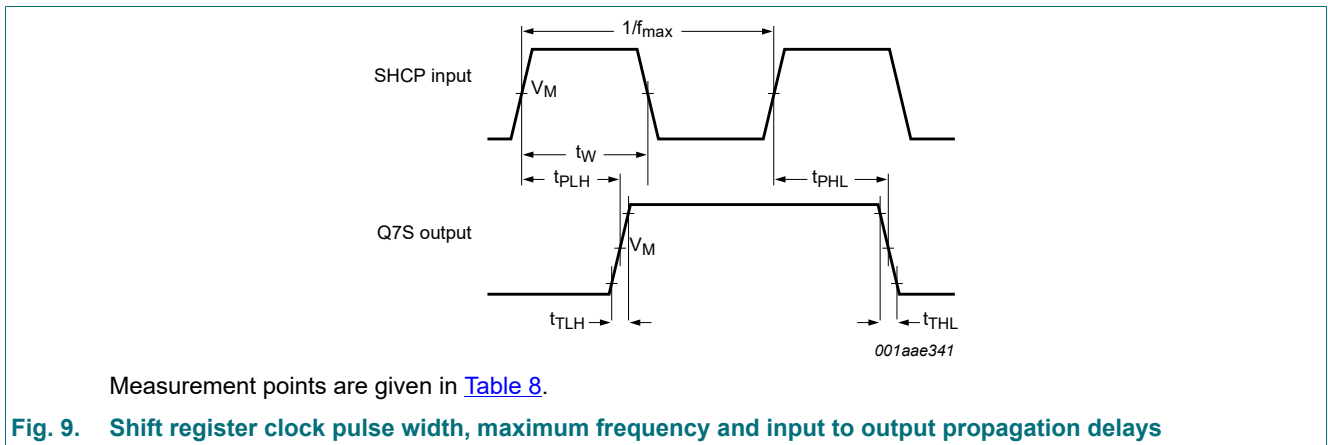



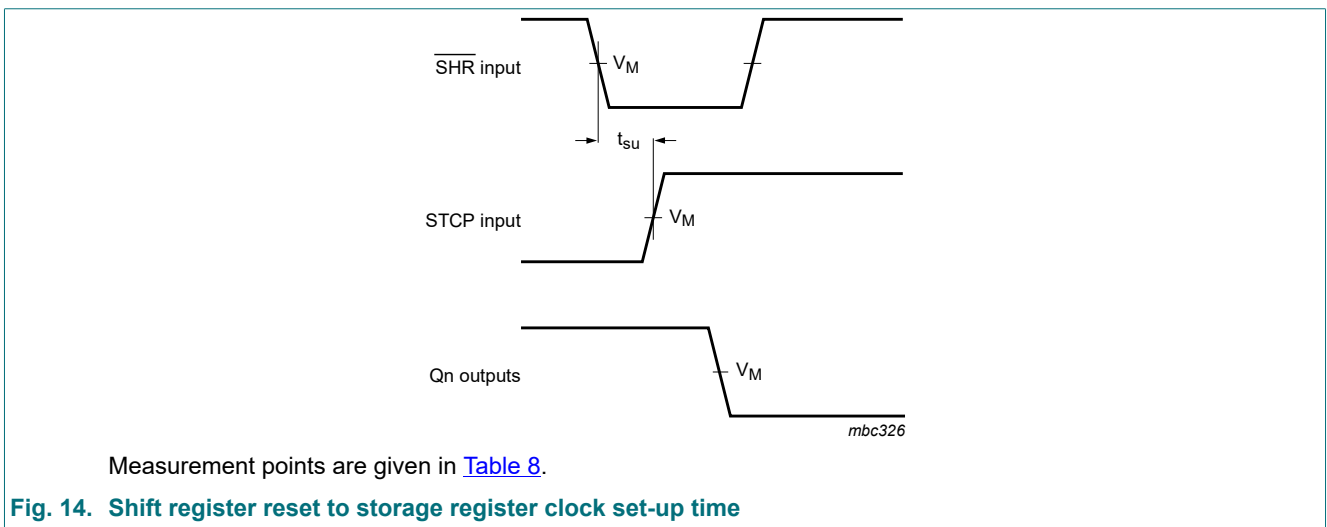

Table 8. Measurement points

Type	Input	Output
	V_M	V_M
74AHC594-Q100	$0.5 \times V_{CC}$	$0.5 \times V_{CC}$
74AHCT594-Q100	1.5 V	$0.5 \times V_{CC}$



001aah768

For test data see [Table 9](#).

Definitions for test circuit:

R_T = Termination resistance should be equal to output impedance Z_o of the pulse generator.

C_L = Load capacitance including jig and probe capacitance.

Fig. 15. Test circuit for measuring switching times

Table 9. Test data

Type	Input		Load	Test
	V_I	t_r, t_f	C_L	
74AHC594-Q100	V_{CC}	≤ 3.0 ns	15 pF, 50 pF	t_{PLH}, t_{PHL}
74AHCT594-Q100	3.0 V	≤ 3.0 ns	15 pF, 50 pF	t_{PLH}, t_{PHL}

12. Package outline

SO16: plastic small outline package; 16 leads; body width 3.9 mm

SOT109-1



Fig. 16. Package outline SOT109-1 (SO16)

SSOP16: plastic shrink small outline package; 16 leads; body width 5.3 mm

SOT338-1

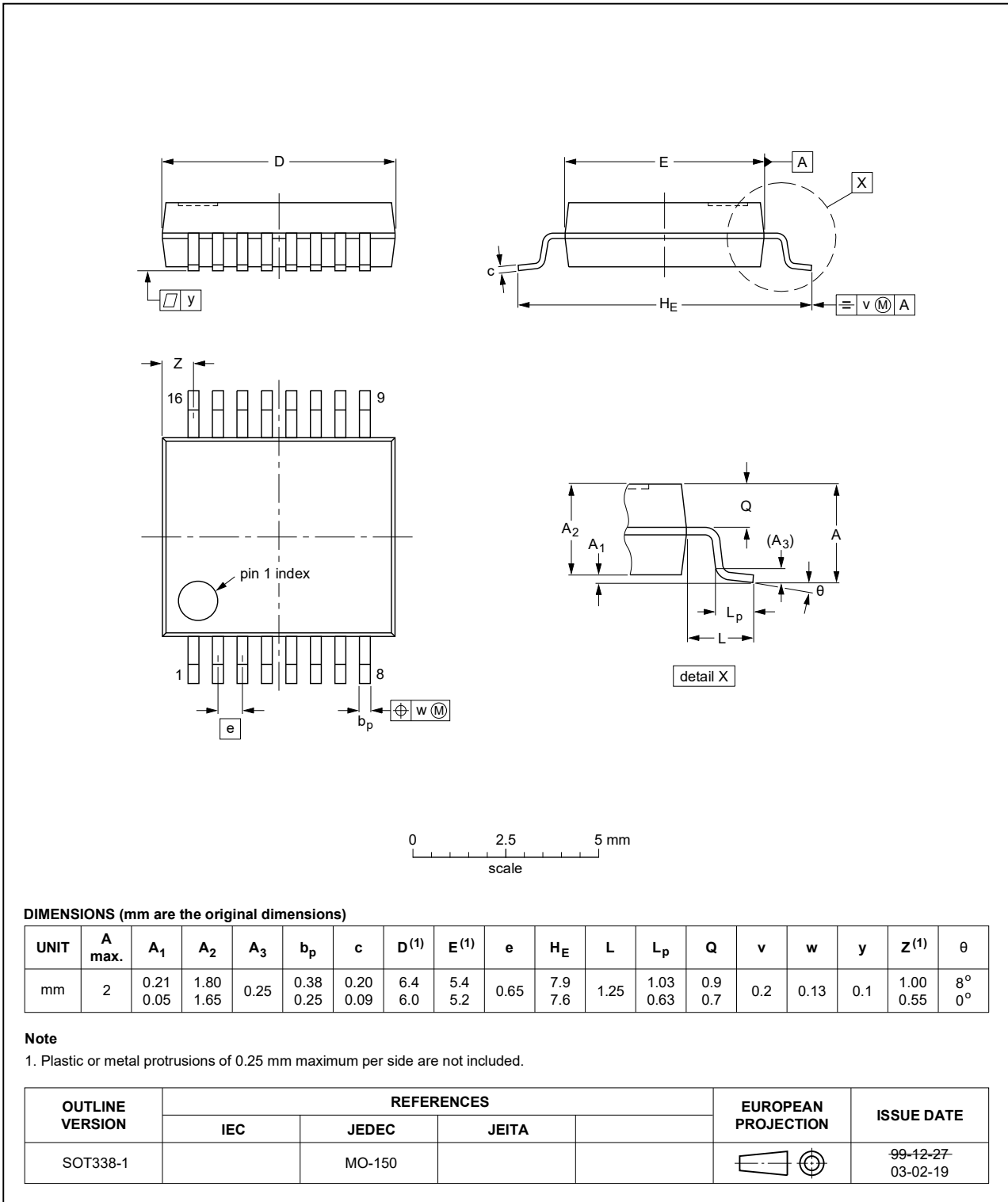

Fig. 17. Package outline SOT338-1 (SSOP16)

TSSOP16: plastic thin shrink small outline package; 16 leads; body width 4.4 mm

SOT403-1



Fig. 18. Package outline SOT403-1 (TSSOP16)

DHVQFN16: plastic dual in-line compatible thermal enhanced very thin quad flat package; no leads; 16 terminals; body 2.5 x 3.5 x 0.85 mm

SOT763-1



Fig. 19. Package outline SOT763-1 (DHVQFN16)

13. Abbreviations

Table 10. Abbreviations

Acronym	Description
CMOS	Complementary Metal-Oxide Semiconductor
DUT	Device Under Test
ESD	ElectroStatic Discharge
HBM	Human Body Model
LSTTL	Low-power Schottky Transistor-Transistor Logic
MIL	Military
MM	Machine Model
TTL	Transistor-Transistor Logic

14. Revision history

Table 11. Revision history

Document ID	Release date	Data sheet status	Change notice	Supersedes
74AHC_AHCT594_Q100 v.3	20200625	Product data sheet	-	74AHC_AHCT594_Q100 v.2
Modifications:	<ul style="list-style-type: none"> The format of this data sheet has been redesigned to comply with the identity guidelines of Nexperia. Legal texts have been adapted to the new company name where appropriate. Type number 74AHC594DB-Q100 (SOT338-1/SSOP16) removed. Section 2 updated. Table 4: Derating values for P_{tot} total power dissipation updated. 			
74AHC_AHCT594_Q100 v.2	20130704	Product data sheet	-	74AHC_AHCT594_Q100 v.1
Modifications:	<ul style="list-style-type: none"> 74AHC594DB-Q100 and 74AHCT594DB-Q100 added. 			
74AHC_AHCT594_Q100 v.1	20120712	Product data sheet	-	-

15. Legal information

Data sheet status

Document status [1][2]	Product status [3]	Definition
Objective [short] data sheet	Development	This document contains data from the objective specification for product development.
Preliminary [short] data sheet	Qualification	This document contains data from the preliminary specification.
Product [short] data sheet	Production	This document contains the product specification.

- [1] Please consult the most recently issued document before initiating or completing a design.
- [2] The term 'short data sheet' is explained in section "Definitions".
- [3] The product status of device(s) described in this document may have changed since this document was published and may differ in case of multiple devices. The latest product status information is available on the internet at <https://www.nexperia.com>.

Definitions

Draft — The document is a draft version only. The content is still under internal review and subject to formal approval, which may result in modifications or additions. Nexperia does not give any representations or warranties as to the accuracy or completeness of information included herein and shall have no liability for the consequences of use of such information.

Short data sheet — A short data sheet is an extract from a full data sheet with the same product type number(s) and title. A short data sheet is intended for quick reference only and should not be relied upon to contain detailed and full information. For detailed and full information see the relevant full data sheet, which is available on request via the local Nexperia sales office. In case of any inconsistency or conflict with the short data sheet, the full data sheet shall prevail.

Product specification — The information and data provided in a Product data sheet shall define the specification of the product as agreed between Nexperia and its customer, unless Nexperia and customer have explicitly agreed otherwise in writing. In no event however, shall an agreement be valid in which the Nexperia product is deemed to offer functions and qualities beyond those described in the Product data sheet.

Disclaimers

Limited warranty and liability — Information in this document is believed to be accurate and reliable. However, Nexperia does not give any representations or warranties, expressed or implied, as to the accuracy or completeness of such information and shall have no liability for the consequences of use of such information. Nexperia takes no responsibility for the content in this document if provided by an information source outside of Nexperia.

In no event shall Nexperia be liable for any indirect, incidental, punitive, special or consequential damages (including - without limitation - lost profits, lost savings, business interruption, costs related to the removal or replacement of any products or rework charges) whether or not such damages are based on tort (including negligence), warranty, breach of contract or any other legal theory.

Notwithstanding any damages that customer might incur for any reason whatsoever, Nexperia's aggregate and cumulative liability towards customer for the products described herein shall be limited in accordance with the Terms and conditions of commercial sale of Nexperia.

Right to make changes — Nexperia reserves the right to make changes to information published in this document, including without limitation specifications and product descriptions, at any time and without notice. This document supersedes and replaces all information supplied prior to the publication hereof.

Suitability for use in automotive applications — This Nexperia product has been qualified for use in automotive applications. Unless otherwise agreed in writing, the product is not designed, authorized or warranted to be suitable for use in life support, life-critical or safety-critical systems or

equipment, nor in applications where failure or malfunction of an Nexperia product can reasonably be expected to result in personal injury, death or severe property or environmental damage. Nexperia and its suppliers accept no liability for inclusion and/or use of Nexperia products in such equipment or applications and therefore such inclusion and/or use is at the customer's own risk.

Quick reference data — The Quick reference data is an extract of the product data given in the Limiting values and Characteristics sections of this document, and as such is not complete, exhaustive or legally binding.

Applications — Applications that are described herein for any of these products are for illustrative purposes only. Nexperia makes no representation or warranty that such applications will be suitable for the specified use without further testing or modification.

Customers are responsible for the design and operation of their applications and products using Nexperia products, and Nexperia accepts no liability for any assistance with applications or customer product design. It is customer's sole responsibility to determine whether the Nexperia product is suitable and fit for the customer's applications and products planned, as well as for the planned application and use of customer's third party customer(s). Customers should provide appropriate design and operating safeguards to minimize the risks associated with their applications and products.

Nexperia does not accept any liability related to any default, damage, costs or problem which is based on any weakness or default in the customer's applications or products, or the application or use by customer's third party customer(s). Customer is responsible for doing all necessary testing for the customer's applications and products using Nexperia products in order to avoid a default of the applications and the products or of the application or use by customer's third party customer(s). Nexperia does not accept any liability in this respect.

Limiting values — Stress above one or more limiting values (as defined in the Absolute Maximum Ratings System of IEC 60134) will cause permanent damage to the device. Limiting values are stress ratings only and (proper) operation of the device at these or any other conditions above those given in the Recommended operating conditions section (if present) or the Characteristics sections of this document is not warranted. Constant or repeated exposure to limiting values will permanently and irreversibly affect the quality and reliability of the device.

Terms and conditions of commercial sale — Nexperia products are sold subject to the general terms and conditions of commercial sale, as published at <http://www.nexperia.com/profile/terms>, unless otherwise agreed in a valid written individual agreement. In case an individual agreement is concluded only the terms and conditions of the respective agreement shall apply. Nexperia hereby expressly objects to applying the customer's general terms and conditions with regard to the purchase of Nexperia products by customer.

No offer to sell or license — Nothing in this document may be interpreted or construed as an offer to sell products that is open for acceptance or the grant, conveyance or implication of any license under any copyrights, patents or other industrial or intellectual property rights.

Export control — This document as well as the item(s) described herein may be subject to export control regulations. Export might require a prior authorization from competent authorities.

Translations — A non-English (translated) version of a document is for reference only. The English version shall prevail in case of any discrepancy between the translated and English versions.

Trademarks

Notice: All referenced brands, product names, service names and trademarks are the property of their respective owners.

Contents

1. General description	1
2. Features and benefits	1
3. Applications	1
4. Ordering information	2
5. Functional diagram	2
6. Pinning information	3
6.1. Pinning.....	3
6.2. Pin description.....	4
7. Functional description	5
8. Limiting values	6
9. Recommended operating conditions	6
10. Static characteristics	7
11. Dynamic characteristics	8
11.1. Waveforms.....	11
12. Package outline	15
13. Abbreviations	19
14. Revision history	19
15. Legal information	20

© Nexperia B.V. 2020. All rights reserved

For more information, please visit: <http://www.nexperia.com>

For sales office addresses, please send an email to: salesaddresses@nexperia.com

Date of release: 25 June 2020



Компания «ЭлектроПласт» предлагает заключение долгосрочных отношений при поставках импортных электронных компонентов на взаимовыгодных условиях!

Наши преимущества:

- Оперативные поставки широкого спектра электронных компонентов отечественного и импортного производства напрямую от производителей и с крупнейших мировых складов;
- Поставка более 17-ти миллионов наименований электронных компонентов;
- Поставка сложных, дефицитных, либо снятых с производства позиций;
- Оперативные сроки поставки под заказ (от 5 рабочих дней);
- Экспресс доставка в любую точку России;
- Техническая поддержка проекта, помощь в подборе аналогов, поставка прототипов;
- Система менеджмента качества сертифицирована по Международному стандарту ISO 9001;
- Лицензия ФСБ на осуществление работ с использованием сведений, составляющих государственную тайну;
- Поставка специализированных компонентов (Xilinx, Altera, Analog Devices, Intersil, Interpoint, Microsemi, Aeroflex, Peregrine, Syfer, Eurofarad, Texas Instrument, Miteq, Cobham, E2V, MA-COM, Hittite, Mini-Circuits, General Dynamics и др.);

Помимо этого, одним из направлений компании «ЭлектроПласт» является направление «Источники питания». Мы предлагаем Вам помощь Конструкторского отдела:

- Подбор оптимального решения, техническое обоснование при выборе компонента;
- Подбор аналогов;
- Консультации по применению компонента;
- Поставка образцов и прототипов;
- Техническая поддержка проекта;
- Защита от снятия компонента с производства.



Как с нами связаться

Телефон: 8 (812) 309 58 32 (многоканальный)

Факс: 8 (812) 320-02-42

Электронная почта: org@eplast1.ru

Адрес: 198099, г. Санкт-Петербург, ул. Калинина, дом 2, корпус 4, литера А.