

New

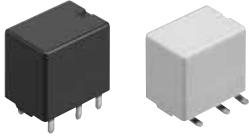

Compliance with RoHS Directive

FEATURES

1. Best space savings in its class.
2. Compact and high-capacity 30A load switching.
3. Full line up (High heat-resistant type and SMD type)
4. Terminals for PC board pattern designs are easily allocated.

TYPICAL APPLICATIONS

Defogger, Seat heater, Head lamp, Fog lamp, Fan motor, etc.

ORDERING INFORMATION

| ACNM | | | | | |
|---|--|--|--|--|--|
| CN-M relay | | | | | |
| Contact arrangement*1 | | | | | |
| 1: 1 Form C | | | | | |
| 3: 1 Form A | | | | | |
| 5: 1 Form C high heat-resistant type | | | | | |
| 7: 1 Form A high heat-resistant type | | | | | |
| Pick-up voltage | | | | | |
| 1: Max. 7.2V DC | | | | | |
| Coil voltage (DC) | | | | | |
| 12: 12V | | | | | |
| Terminal shape | | | | | |
| Nil: PC board terminal | | | | | |
| SA: Surface-mount terminal | | | | | |
| Packing style*2 | | | | | |
| Nil: Tube packing | | | | | |
| X: Tape and reel packing (Reverse NO terminal direction in pull-out direction) | | | | | |
| Z: Tape and reel packing (Normal NO terminal direction in pull-out direction) | | | | | |

Notes: *1. Surface-mount terminal type is available in high heat-resistant type only.

*2. Tube packing: PC board terminal type only
Tape and reel packing: Surface-mount type only

TYPES

1. PC board terminal type

| Contact arrangement | Nominal coil voltage | Part No. | |
|---------------------|----------------------|---------------|--------------------------|
| | | Standard type | High heat-resistant type |
| 1 Form A | 12V DC | ACNM3112 | ACNM7112 |
| 1 Form C | | ACNM1112 | ACNM5112 |

Standard packing; Carton (tube): 50 pcs.; Case: 1,500 pcs.

2. Surface-mount terminal type

| Contact arrangement | Nominal coil voltage | Part No. |
|---------------------|----------------------|--------------------------|
| | | High heat-resistant type |
| 1 Form A | 12V DC | ACNM7112SAX |
| | | ACNM7112SAZ |
| 1 Form C | | ACNM5112SAX |
| | | ACNM5112SAZ |

Standard packing; Carton (tape and reel): 200 pcs.; Case: 600 pcs.

Notes: *1. Surface-mount terminal type is available in high heat-resistant type only.

*2. An "X" at the end of the part number indicates, for tape and reel packing, reverse NO terminal direction in pull-out direction.
A "Z" at the end of the part number indicates, for tape and reel packing, normal NO terminal direction in pull-out direction.

CN-M (ACNM)

RATING

1. Coil data

| Nominal coil voltage | Pick-up voltage (at 20°C 68°F) | Drop-out voltage (at 20°C 68°F) | Nominal operating current [$\pm 10\%$] (at 20°C 68°F) | Coil resistance [$\pm 10\%$] (at 20°C 68°F) | Nominal operating power (at 20°C 68°F) | Usable voltage range |
|----------------------|--------------------------------|---------------------------------|---|---|--|----------------------|
| 12 V DC | Max. 7.2 V DC (Initial) | Min. 1.0 V DC (Initial) | 53.3 mA | 225 Ω | 640 mW | 10 to 16 V DC |

2. Specifications

| Characteristics | Item | Specifications | |
|-----------------------------------|---|---|--|
| Contact | Arrangement | 1 Form A, 1 Form C | |
| | Contact resistance (Initial) | Typical 5m Ω (By voltage drop 6 V DC 1 A) | |
| | Contact material | Ag alloy (Cadmium free) | |
| Rating | Nominal switching capacity (resistive load) | N.O.: 30A 14V DC, N.C.: 15A 14V DC | |
| | Max. carrying current (at 14V DC) | N.O. 30A/1 h, 40A/2 min. at 20°C 68°F 25A/1 h, 35A/2 min. at 85°C 185°F 20A/1 h, 30A/2 min. at 110°C 230°F (High heat-resistant type) | |
| | | N.C. 25A/1 h, 30A/2 min. at 20°C 68°F 20A/1 h, 25A/2 min. at 85°C 185°F 15A/1 h, 20A/2 min. at 110°C 230°F (High heat-resistant type) | |
| | | Nominal operating power | 640 mW |
| | Min. switching capacity (resistive load)* | 1A 12V DC | |
| Electrical characteristics | Insulation resistance (Initial) | Min. 100 M Ω (at 500 V DC) | |
| | Breakdown voltage (Initial) | Between open contacts | 500 Vrms for 1 min. (Detection current: 10mA) |
| | | Between contacts and coil | 500 Vrms for 1 min. (Detection current: 10mA) |
| | Operate time (at nominal voltage) | Max. 10ms (at 20°C 68°F, excluding contact bounce time) (Initial) | |
| Release time (at nominal voltage) | Max. 10ms (at 20°C 68°F, excluding contact bounce time) (Initial) (without diode) | | |
| Mechanical characteristics | Shock resistance | Functional | Min. 100 m/s ² {10G} (Half-wave pulse of sine wave: 11ms; detection time: 10 μ s) |
| | | Destructive | Min. 1,000 m/s ² {100G} (Half-wave pulse of sine wave: 6ms) |
| | Vibration resistance | Functional | 10 Hz to 100 Hz, Min. 44.1m/s ² {4.5G} (Detection time: 10 μ s) |
| | | Destructive | 10 Hz to 500 Hz, Min. 44.1m/s ² {4.5G} Time of vibration for each direction; X, Y direction: 2 hours, Z direction: 4 hours |
| Expected life | Mechanical | Min. 10 ⁷ (at 120 cpm) | |
| | | <Resistive load> Min. 10 ⁵ (At nominal switching capacity, operating frequency: 1s ON, 2s OFF) | |
| | | <Motor load> Min. 2 \times 10 ⁵ : at 80 A (inrush), 16 A (steady), 14 V DC (Operating frequency: 2s ON, 6s OFF) | |
| | | <Lamp load> Min. 10 ⁵ : at 84 A (inrush), 12 A (steady), 14 V DC (Operating frequency: 1s ON, 14s OFF) | |
| Conditions | Conditions for operation, transport and storage | Standard type; Ambient temp: -40°C to +85°C -40°F to +185°F, Humidity: 5 to 85% R.H. | |
| | | High heat-resistant type; Ambient temp: -40°C to +110°C -40°F to +230°F, Humidity: 2 to 85% R.H. (Not freezing and condensing at low temperature) | |
| Unit weight | | Approx. 5.5 g .19 oz | |

Note: *This value can change due to the switching frequency, environmental conditions, and desired reliability level, therefore it is recommended to check this with the actual load.

REFERENCE DATA

1-(1). Coil temperature rise

Sample: ACNM1112, 3pcs
Measured portion: Inside the coil
Contact carrying current: 10A, 20A, 30A
Ambient temperature: 26°C 78.8°F

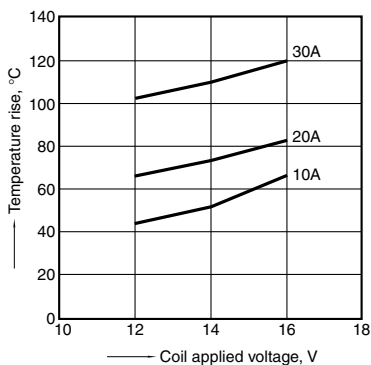

1-(2). Coil temperature rise

Sample: ACNM7112, 3pcs
Measured portion: Inside the coil
Contact carrying current: 10A, 20A
Ambient temperature: 110°C 230°F

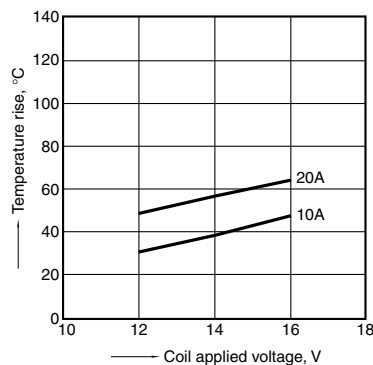

2. Ambient temperature and operating voltage range

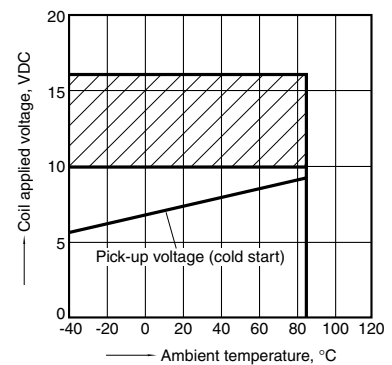

3. Distribution of pick-up and drop-out voltage

Sample: ACNM1112, 20pcs.

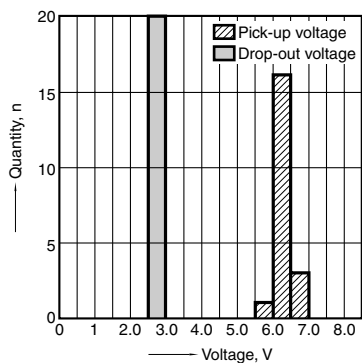

4. Distribution of operate and release time

Sample: ACNM1112, 20pcs.

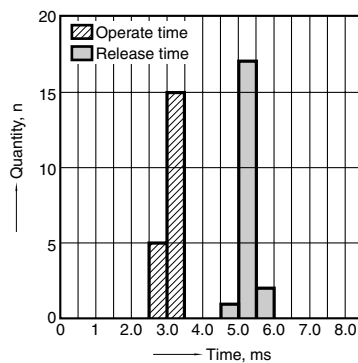

5-(1). Electrical life test (Resistive load)

Sample: ACNM1112, 3pcs.

Load: Resistive load (NO side: 30A 14V DC)

Operating frequency: (ON:OFF = 1s:1s)

Ambient temperature: Room temperature

Circuit:

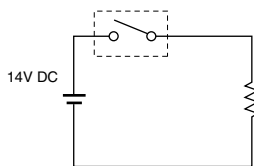

Change of pick-up and drop-out voltage

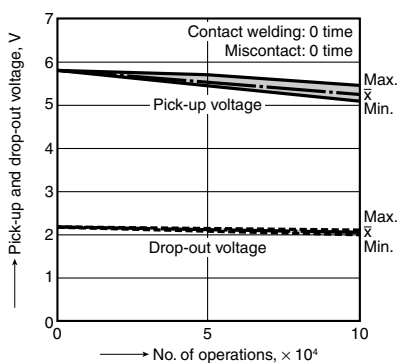

Change of contact resistance

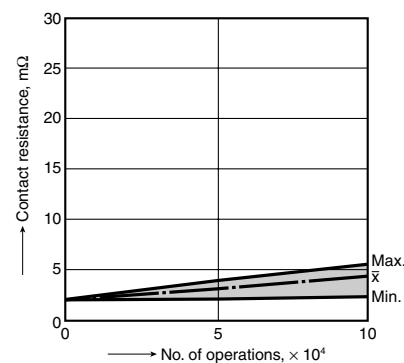

5-(2). Electrical life test (Motor load)

Sample: ACNM7112, 3pcs.

Load: inrush: 80A/steady: 16A, radiator fan actual load (motor free)

Switching frequency: (ON:OFF = 2s:6s)

Ambient temperature: 110°C 230°F

Circuit:

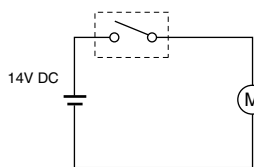

Change of pick-up and drop-out voltage

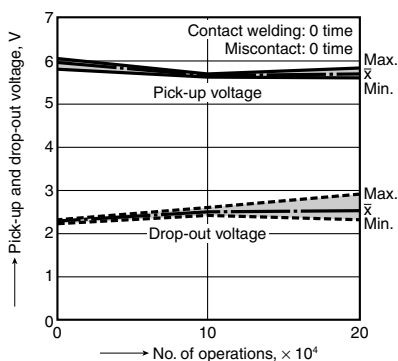

Change of contact resistance

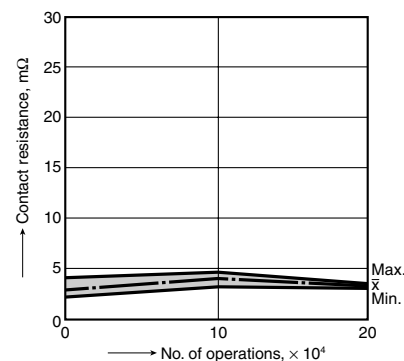

5-(3). Electrical life test (Lamp load)

Sample: ACNM3112, 3pcs.

Load: inrush: 84A/steady: 12A

Switching frequency: (ON:OFF = 1s:14s)

Ambient temperature: Room temperature

Circuit:

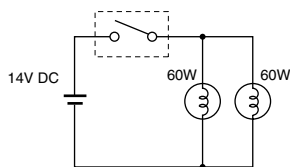

Change of pick-up and drop-out voltage

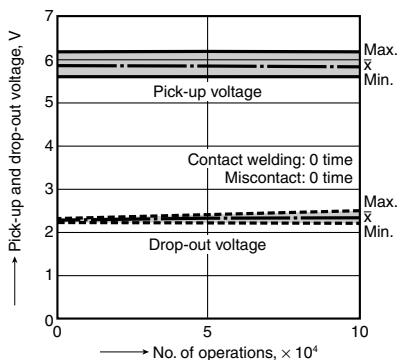

Change of contact resistance

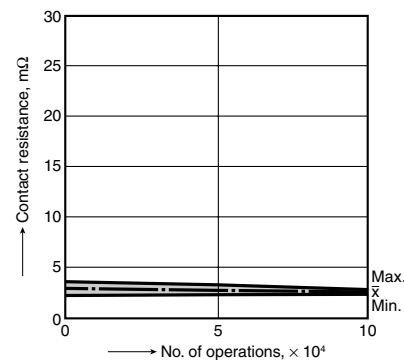

CN-M (ACNM)

DIMENSIONS (Unit: mm inch)

1. PC board terminal type



External dimensions

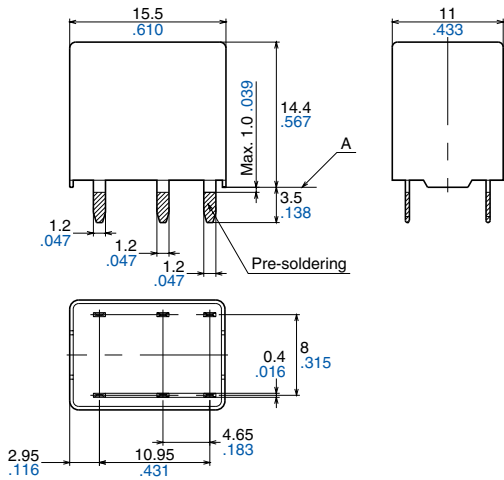

| | |
|-----------------------------|--------------------------|
| Dimension: | General tolerance |
| Max. 1mm .039 inch: | $\pm 0.1 \pm 0.04$ |
| 1 to 3mm .039 to .118 inch: | $\pm 0.2 \pm 0.08$ |
| Min. 3mm .118 inch: | $\pm 0.3 \pm 0.12$ |

PC board pattern (Bottom view)

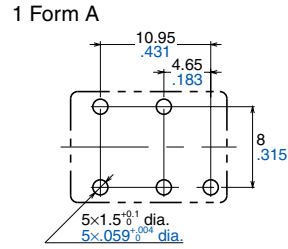

Schematic (Bottom view)

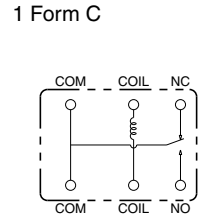
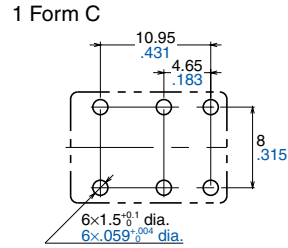
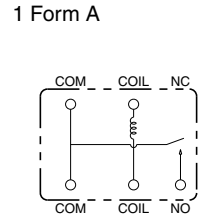

* Dimensions (thickness and width) of terminal specified in this catalog is measured before pre-soldering. Intervals between terminals is measured at A surface level.

Tolerance: $\pm 0.1 \pm 0.04$

2. Surface-mount terminal type



External dimensions

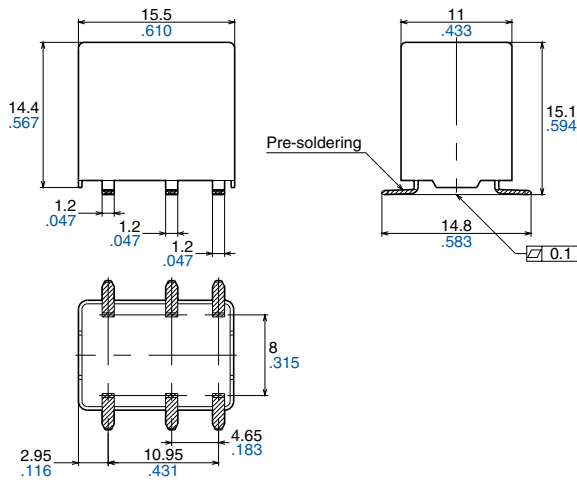

| | |
|-----------------------------|--------------------------|
| Dimension: | General tolerance |
| Max. 1mm .039 inch: | $\pm 0.1 \pm 0.04$ |
| 1 to 3mm .039 to .118 inch: | $\pm 0.2 \pm 0.08$ |
| Min. 3mm .118 inch: | $\pm 0.3 \pm 0.12$ |

Recommended mounting pad (Top view)

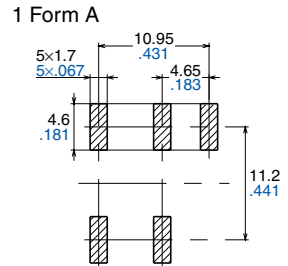

Schematic (Top view)

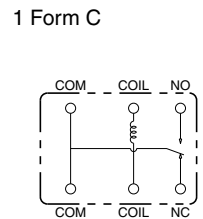
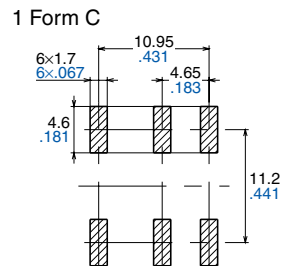
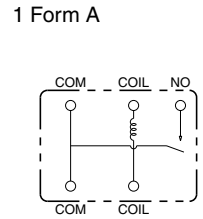

Tolerance: $\pm 0.1 \pm 0.04$

NOTES

1. Coil operating power

Pure DC current should be applied to the coil. The wave form should be rectangular. If it includes ripple, the ripple factor should be less than 5%. However, check it with the actual circuit since the characteristics may be slightly different.

2. Coil applied voltage

To ensure proper operation, the voltage applied to the coil should be the rated operating voltage of the coil. Also, be aware that the pick-up and drop-out voltages will fluctuate depending on the ambient temperature and operating conditions.

3. Cycle lifetime

Check this with the real device as it is affected by coil driving circuit, load type, activation frequency, activation phase, ambient conditions and other factors.

4. Soldering

When soldering the relays, ensure conformance with the conditions listed below.

1) Automatic soldering

- Preheating: less than 100°C 212°F (solder target surface of PC board) for less than 120 sec

- Soldering: less than 260°C 500°F (solder temperature) for less than 5 sec (soldering time)

2) Manual soldering

- Soldering tip temperature: less than 280 to 300°C 536 to 572°F
- Soldering iron: 30 to 60 W
- Soldering time: less than 5 sec

5. Usage, transport and storage conditions

1) Ambient temperature, humidity, and atmospheric pressure during usage, transport, and storage of the relay:

(1) Temperature:
-40 to +85°C -40 to +185°F

(Standard type)
-40 to +110°C -40 to +230°F
(High heat-resistant type)

(2) Humidity: 2 to 85% RH
(Avoid freezing and condensation.)

(3) Atmospheric pressure: 86 to 106 kPa
The humidity range varies with the temperature. Use within the range indicated in the graph below.

(Temperature and humidity range for usage, transport, and storage)

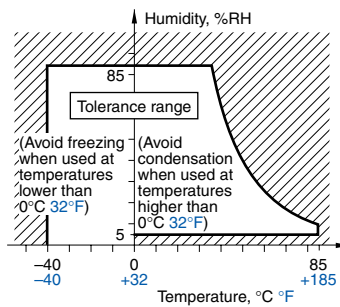
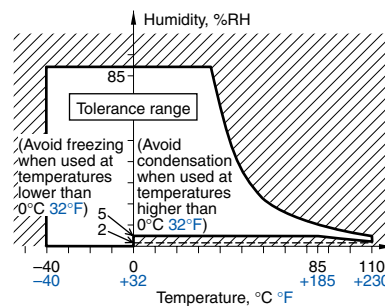

2) Condensation

Condensation forms when there is a sudden change in temperature under high temperature and high humidity conditions. Condensation will cause deterioration of the relay insulation.

3) Freezing

Condensation or other moisture may freeze on the relay when the temperatures is lower than 0°C 32°F. This causes problems such as sticking of movable parts or operational time lags.

4) Low temperature, low humidity environments

The plastic becomes brittle if the relay is exposed to a low temperature, low humidity environment for long periods of time.

6. Others

If the relay has been dropped, the appearance and characteristics should always be checked before use.



Компания «ЭлектроПласт» предлагает заключение долгосрочных отношений при поставках импортных электронных компонентов на взаимовыгодных условиях!

Наши преимущества:

- Оперативные поставки широкого спектра электронных компонентов отечественного и импортного производства напрямую от производителей и с крупнейших мировых складов;
- Поставка более 17-ти миллионов наименований электронных компонентов;
- Поставка сложных, дефицитных, либо снятых с производства позиций;
- Оперативные сроки поставки под заказ (от 5 рабочих дней);
- Экспресс доставка в любую точку России;
- Техническая поддержка проекта, помощь в подборе аналогов, поставка прототипов;
- Система менеджмента качества сертифицирована по Международному стандарту ISO 9001;
- Лицензия ФСБ на осуществление работ с использованием сведений, составляющих государственную тайну;
- Поставка специализированных компонентов (Xilinx, Altera, Analog Devices, Intersil, Interpoint, Microsemi, Aeroflex, Peregrine, Syfer, Eurofarad, Texas Instrument, Miteq, Cobham, E2V, MA-COM, Hittite, Mini-Circuits, General Dynamics и др.);

Помимо этого, одним из направлений компании «ЭлектроПласт» является направление «Источники питания». Мы предлагаем Вам помощь Конструкторского отдела:

- Подбор оптимального решения, техническое обоснование при выборе компонента;
- Подбор аналогов;
- Консультации по применению компонента;
- Поставка образцов и прототипов;
- Техническая поддержка проекта;
- Защита от снятия компонента с производства.



Как с нами связаться

Телефон: 8 (812) 309 58 32 (многоканальный)

Факс: 8 (812) 320-02-42

Электронная почта: org@eplast1.ru

Адрес: 198099, г. Санкт-Петербург, ул. Калинина, дом 2, корпус 4, литера А.