

**Mini-Mac
Applicator
Air Feed-Mylar Tape**

**Application Tooling
Specification Sheet**

Order No. 63885-9100

FEATURES

- Directly adapts to most crimp presses and automatic wire processors
- Applicator designed to industry standard mounting and shut height of 135.80mm (5.346")
- Conductor and insulation rings allow quick adjustment for conductor and insulation crimp height change
- Quick set-up time; plus the crimp height, track and feed adjustments can be set without removing the applicator from the crimp press

SCOPE

Products: Avikrimp™ Butt Splices 18-22 AWG.

Testing

Mechanical

The tensile test, or pull test, is a means of evaluating the mechanical properties of the crimped connections. The following chart shows the UL and government specifications (MIL-T-7928) for various wire sizes. The tensile strength is shown in pounds and it indicates the minimum acceptable force to break or separate the terminal from the conductor.

Color Code	Wire Size (AWG)	*UL - 486 A	*UL - 486 C	*UL - 310	*Military Class 2
Yellow	26	3	N/A	N/A	7
Yellow	24	5	N/A	N/A	10
Red	22	8	8	8	15
Red	20	13	10	13	19
Red	18	20	10	20	38
Blue	16	30	15	30	50
Blue	14	50	25	50	70
Yellow	12	70	35	70	110
Yellow	10	80	40	80	150
Red	8	90	45	N/A	225
Blue	6	100	50	N/A	300

*UL - 486 A - Terminals (Copper conductors only)

*UL - 486 C - Butt Splices, Parallel Splices, Closed End Connectors, and Wire Nuts

*UL - 310 - Quick Disconnects, Flag and Couplers

*Military Class 2- Military Approved Terminals only as listed

Product List

The following is a partial list of the product order numbers and their specifications that this tool is designed to run. Updates to this list are available on www.molex.com.

Wire Size: 18 – 22 AWG					
Terminal No.	Terminal Engineering No. (REF)	Wire Strip Length		Insulation Diameter Maximum	
		In.	mm	In.	mm
19199-0002	A-845T	.312	7.94	.140	3.55
19199-0008	WA-840T	.312	7.94	.140	3.55
19200-0022	AS-845T	.312	7.94	.140	3.55

DEFINITION OF TERMS

The following illustrations are a generic terminal representation and not an exact image of any terminal listed in the scope.

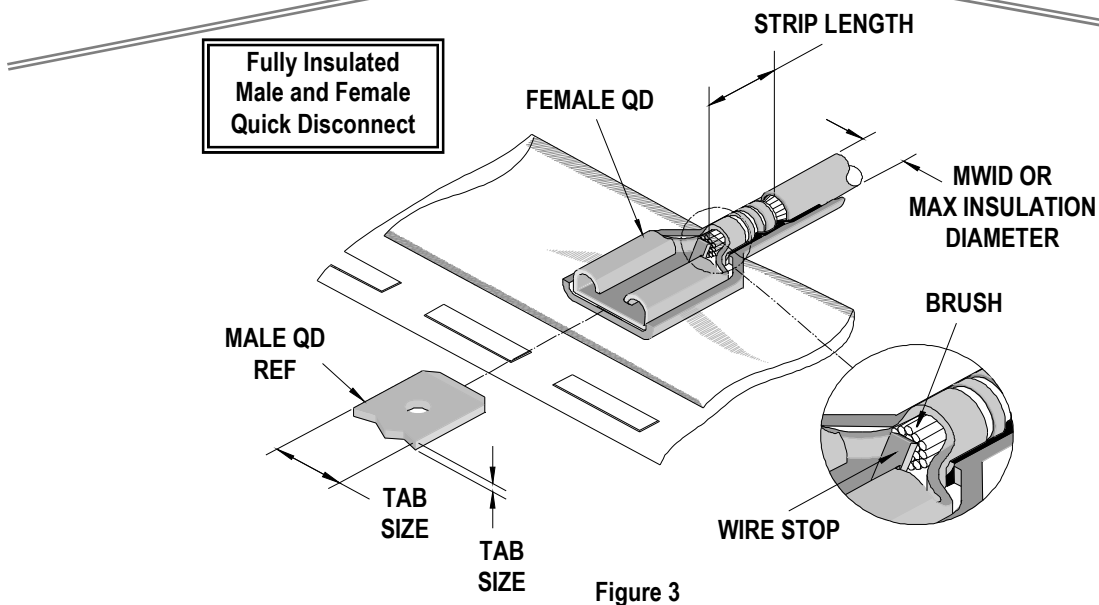
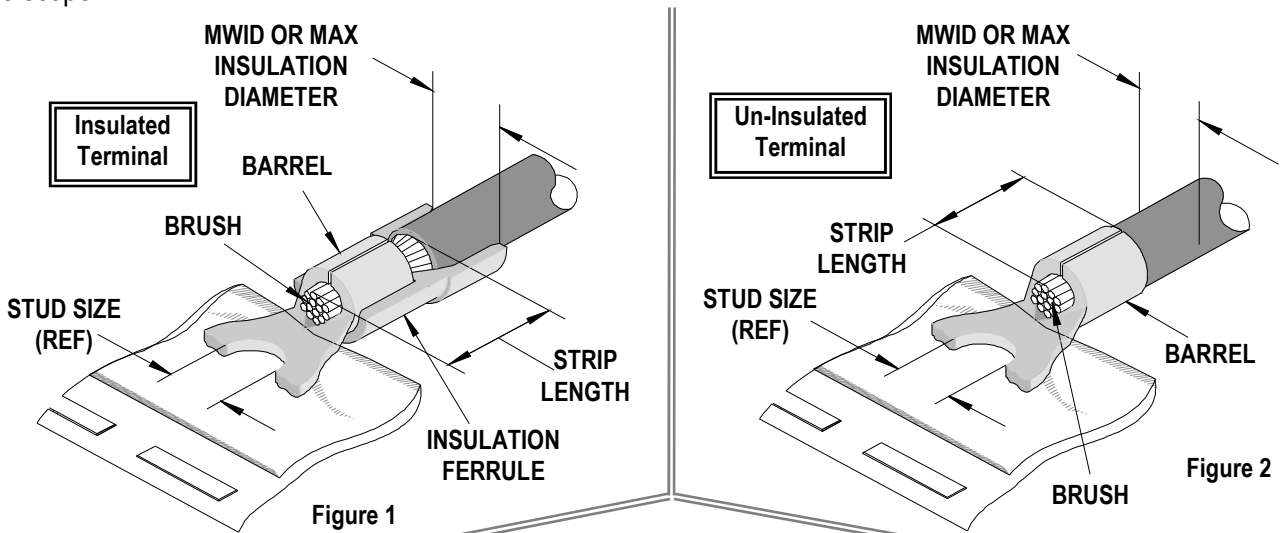

Tool Calibration

To recalibrate this applicator, make sure the power is completely shut off on the press.

1. The Mini-Mac applicator must be properly installed in the press.
2. Crimping dies must be properly installed in the Mini-Mac applicator.
3. The recommended method of measuring the crimp height of the conductor dies is the soft metal slug method, (See Figure 4).
4. The slug must have a diameter 0.51mm (.020") larger than the "X" No Go dimension before crimping.
5. Place the soft metal slug (solder) into the nest of the bottom die and crimp (by hand cycling the press) similar to a terminal. The crimp height can be measured with a blade type micrometer or dial caliper, (Dimension "X").
6. Adjustment of the crimp height can be accomplished by indexing the conductor cam. The letter "A" gives the loosest position and "K" gives the tightest position. A total adjustment of 0.50mm (.020") can be achieved by adjusting the conductor cam.

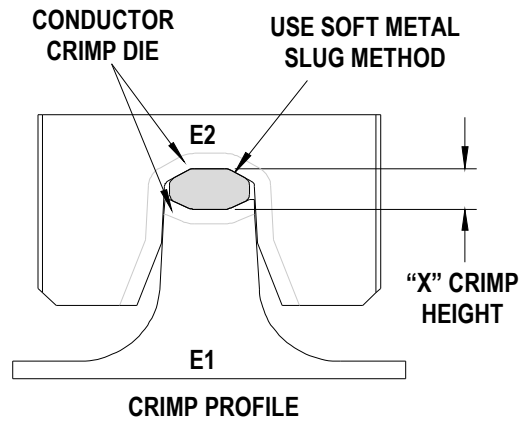

Use soft metal slug (solder) method to Measure the "X" dimension. Verify tooling crimp height calibration by referring to the Go/No Go dimensions shown in the chart below.

Figure 4

Note: If the crimp height is too tight on the setting "A", check the shut height of the press. See the Industrial Mini-Mac Applicator Manual Section 2.1 for adjustments.

CRIMP SPECIFICATIONS

Wire Size		"X" Dimension Conductor Crimp						Pull Force Minimum	
AWG	mm ²	Mean		Go		No Go		Lbs.	N
		In.	mm	In.	mm	In.	mm		
18	0.80	.105	2.68	.102	2.59	.108	2.74	10.0	44.5
20	0.50	.105	2.68	.102	2.59	.108	2.74	10.0	44.5
22	0.35	.105	2.68	.102	2.59	.108	2.74	8.0	35.6

Tool Qualification Notes:

1. Pull Force should be measured with no influence from the insulation crimp.
2. The above specifications are guidelines to an optimum crimp.

PARTS LIST

Mini-Mac Applicator 63885-9100				
Item	Order No	Engineering No.	Description	Quantity
Perishable Tooling				
	63885-9170	63885-9170	Tool Kit (All "Y" Items)	REF
1	63465-0085	63465-0085	Conductor Punch	1 Y
2	63464-0072	63464-0072	Conductor Anvil	1 Y
3	63463-0048	63463-0048	Insulation Punch	1 Y
4	63462-0051	63462-0051	Insulation Anvil	1 Y
Other Components				
5	63466-0912	63466-0912	Anvil Mount	1
6	63466-0913	63466-0913	Terminal Support	1
7	63443-0021	63443-0021	Lower Tooling Key	1
8	63466-0921	63466-0921	Terminal Stripping Blade	1
9	63600-1290	63600-1290	Washer	1
10	63890-0866	63890-0866	Collar-6.4mm Lg.	1
11	63890-0867	63890-0867	Collar-7.7mm Lg.	1
Frame				
12	63801-3301	63801-3301	Air Feed Applicator Frame Head	REF
13	63801-3281	63801-3281	Base	REF
14	63801-5850	63801-5850	Track Assembly	REF
15	63801-3390	63801-3390	Air Kit	REF
Hardware				
16	N/A	N/A	M3 by 12 Lg SHCS	1**
17	N/A	N/A	M4 by 10 Lg SHCS	2**
18	N/A	N/A	M4 by 20 Lg. SHCS	1**
19	N/A	N/A	M4 by 50 Lg. SHCS	1**
20	N/A	N/A	M8 by 30 Lg. BHCS	1**
21	N/A	N/A	3mm by 6 Lg. Roll Pin	1**
** Available from an industrial supply company such as MSC (1-800-645-7270).				

Note: Crimp profiles used in 63885-9100 are equivalent to 19288-0043/ATP-AA-516.

Assembly Drawing

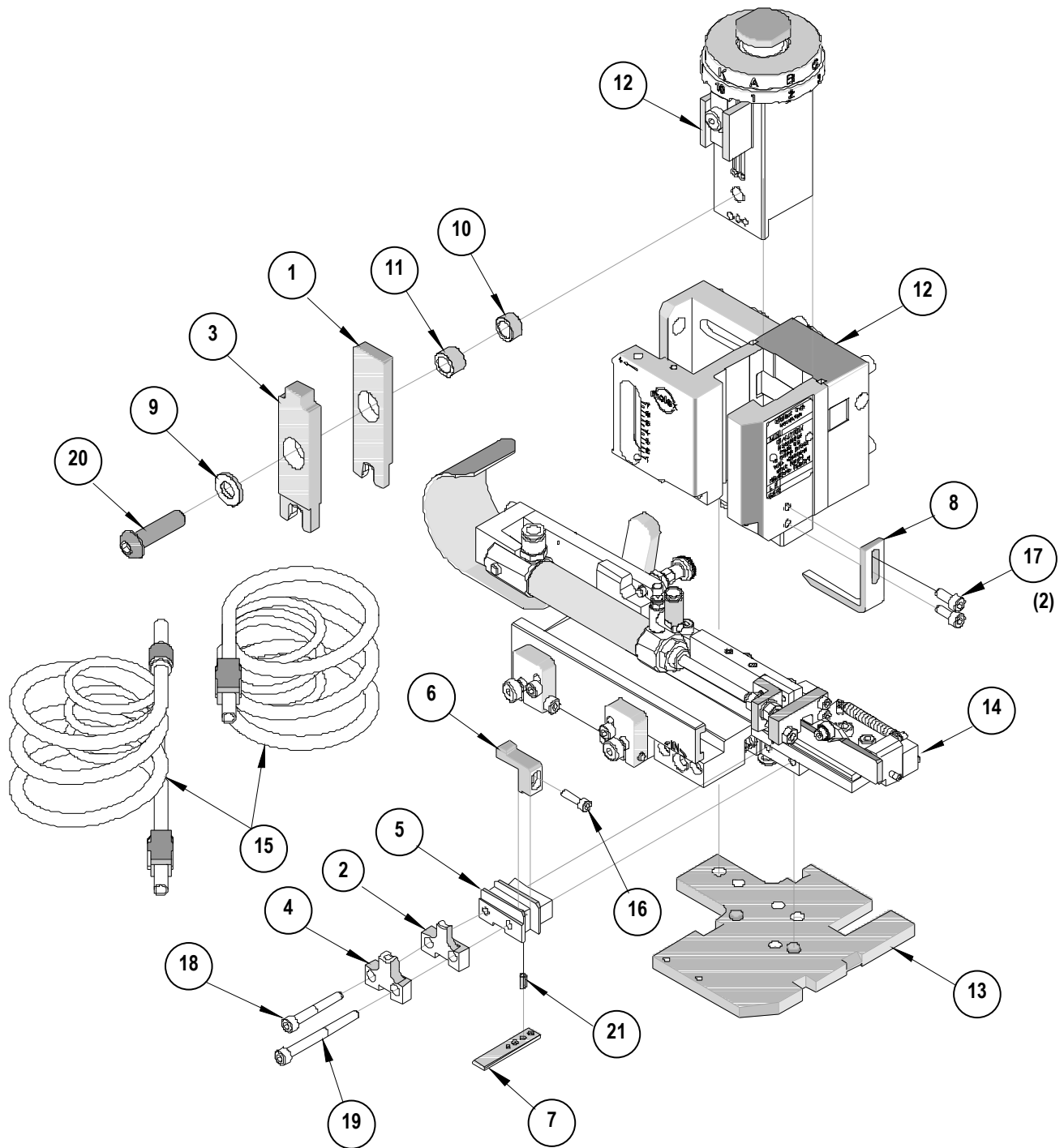

Figure 5

NOTES

1. Molex recommends an extra perishable tooling kit be maintained at your facility.
2. Verify tooling alignment by manually cycling the press with applicator before crimping under power. Check that all screws are tight.
3. Slugs, terminals, dirt, and oil should be kept clear of work area.
4. Wear safety glasses at all times.
5. For recommended maintenance refer to the Mini-Mac Applicator Manual (Document no. 63880-0000).

CAUTION: This applicator should only be used in a press with a shut height of 135.80 mm (5.346"). Tooling damage could result at a lower setting.

CAUTION: To prevent injury, never operate this applicator without the guards supplied with the press or wire-processing machine in place. Reference the press or wire processing manufacturer's instruction manual.

CAUTION: Molex crimp specifications are valid only when used with Molex terminals, applicators and tooling.

Contact Information

For more information on Molex application tooling please contact Molex at 1-800-786-6539.

Visit our Web site at <http://www.molex.com>



Компания «ЭлектроПласт» предлагает заключение долгосрочных отношений при поставках импортных электронных компонентов на взаимовыгодных условиях!

Наши преимущества:

- Оперативные поставки широкого спектра электронных компонентов отечественного и импортного производства напрямую от производителей и с крупнейших мировых складов;
- Поставка более 17-ти миллионов наименований электронных компонентов;
- Поставка сложных, дефицитных, либо снятых с производства позиций;
- Оперативные сроки поставки под заказ (от 5 рабочих дней);
- Экспресс доставка в любую точку России;
- Техническая поддержка проекта, помощь в подборе аналогов, поставка прототипов;
- Система менеджмента качества сертифицирована по Международному стандарту ISO 9001;
- Лицензия ФСБ на осуществление работ с использованием сведений, составляющих государственную тайну;
- Поставка специализированных компонентов (Xilinx, Altera, Analog Devices, Intersil, Interpoint, Microsemi, Aeroflex, Peregrine, Syfer, Eurofarad, Texas Instrument, Miteq, Cobham, E2V, MA-COM, Hittite, Mini-Circuits, General Dynamics и др.);

Помимо этого, одним из направлений компании «ЭлектроПласт» является направление «Источники питания». Мы предлагаем Вам помощь Конструкторского отдела:

- Подбор оптимального решения, техническое обоснование при выборе компонента;
- Подбор аналогов;
- Консультации по применению компонента;
- Поставка образцов и прототипов;
- Техническая поддержка проекта;
- Защита от снятия компонента с производства.



Как с нами связаться

Телефон: 8 (812) 309 58 32 (многоканальный)

Факс: 8 (812) 320-02-42

Электронная почта: org@eplast1.ru

Адрес: 198099, г. Санкт-Петербург, ул. Калинина, дом 2, корпус 4, литера А.