



A New Direction in Mixed-Signal

# CLC1007, CLC2007, CLC4007

Single, Dual, and Quad Low Cost, High Speed RRO Amplifiers

## General Description

The CLC1007 (single), CLC2007 (dual) and CLC4007(quad) are low cost, voltage feedback amplifiers. These amplifiers are designed to operate on +3V to +5V, or  $\pm 5V$  supplies. The input voltage range extends 300mV below the negative rail and 0.9V below the positive rail.

The CLC1007, CLC2007, and CLC4007 offer superior dynamic performance with a 260MHz small signal bandwidth and 220V/ $\mu$ s slew rate. The combination of low power, high output current drive, and rail-to-rail performance make these amplifiers well suited for battery-powered communication/computing systems.

The combination of low cost and high performance make the CLC1007, CLC2007, and CLC4007 suitable for high volume applications in both consumer and industrial applications such as wireless phones, scanners, color copiers, and video transmission.

## FEATURES

- 260MHz bandwidth
- Fully specified at +3V, +5V and  $\pm 5V$  supplies
- Output voltage range:
  - 0.03V to 4.95V;  $V_S = +5$ ;  $R_L = 2k\Omega$
- Input voltage range:
  - -0.3V to +4.1V;  $V_S = +5$
- 220V/ $\mu$ s slew rate
- 2.6mA supply current per amplifier
- $\pm 100mA$  linear output current
- $\pm 125mA$  short circuit current
- CLC2007 directly replaces LMH6643, AD8042, AD8052, and AD8092
- CLC1007 directly replaces LMH6642, AD8041, AD8051, and AD8091

## APPLICATIONS

- A/D driver
- Active filters
- CCD imaging systems
- CD/DVD ROM
- Coaxial cable drivers
- High capacitive load driver
- Portable/battery-powered applications
- Twisted pair driver
- Telecom and optical terminals
- Video driver

Ordering Information - [page 26](#)

## Large Signal Frequency Response

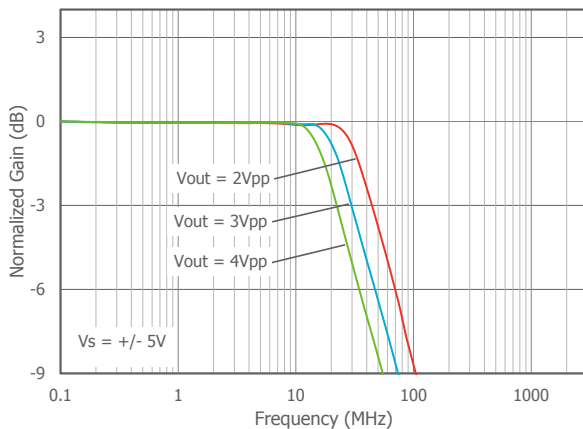

## Output Voltage Swing vs Competition

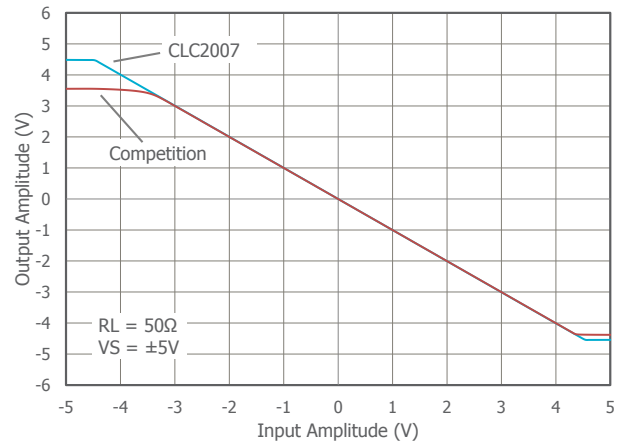

## Absolute Maximum Ratings

Stresses beyond the limits listed below may cause permanent damage to the device. Exposure to any Absolute Maximum Rating condition for extended periods may affect device reliability and lifetime.

$V_S$  ..... 0V to +14V  
 $V_{IN}$  .....  $-V_S - 0.5V$  to  $+V_S + 0.5V$

## Operating Conditions

Supply Voltage Range ..... 2.7 to 12.6V  
 Operating Temperature Range .....  $-40^{\circ}C$  to  $125^{\circ}C$   
 Junction Temperature .....  $150^{\circ}C$   
 Storage Temperature Range .....  $-65^{\circ}C$  to  $150^{\circ}C$   
 Lead Temperature (Soldering, 10s) .....  $260^{\circ}C$

## Package Thermal Resistance

$\theta_{JA}$  (TSOT23-5) .....  $215^{\circ}C/W$   
 $\theta_{JA}$  (SOIC-8) .....  $150^{\circ}C/W$   
 $\theta_{JA}$  (MSOP-8) .....  $200^{\circ}C/W$   
 $\theta_{JA}$  (SOIC-14) .....  $90^{\circ}C/W$   
 $\theta_{JA}$  (TSSOP-14) .....  $100^{\circ}C/W$   
 Package thermal resistance ( $\theta_{JA}$ ), JEDEC standard, multi-layer test boards, still air.

## ESD Protection

TSOT-5 (HBM) ..... 1kV  
 SOIC-8 (HBM) ..... 1kV  
 TSOT-5 (CDM) ..... 2kV  
 SOIC-8 (CDM) ..... 2kV  
 ESD Rating for HBM (Human Body Model) and CDM (Charged Device Model).

## Electrical Characteristics at +3V

$T_A = 25^\circ\text{C}$ ,  $V_S = +3\text{V}$ ,  $R_f = 1.5\text{k}\Omega$ ,  $R_L = 2\text{k}\Omega$  to  $V_S/2$ ;  $G = 2$ ; unless otherwise noted.

Symbol	Parameter	Conditions	Min	Typ	Max	Units
Frequency Domain Response						
GBWP	-3dB Gain Bandwidth Product	$G = +11$ , $V_{OUT} = 0.2V_{pp}$		90		MHz
UGBW	Unity Gain Bandwidth	$V_{OUT} = 0.2V_{pp}$ , $R_F = 0$		245		MHz
BW <sub>SS</sub>	-3dB Bandwidth	$V_{OUT} = 0.2V_{pp}$		85		MHz
$f_{0.1dB}$	0.1dB Gain Flatness	$V_{OUT} = 0.2V_{pp}$ , $R_L = 150\Omega$		16		MHz
BW <sub>LS</sub>	Large Signal Bandwidth	$V_{OUT} = 2V_{pp}$		55		MHz
DG	Differential Gain	DC-coupled Output		0.03		%
		AC-coupled Output		0.04		%
DP	Differential Phase	DC-coupled Output		0.03		°
		AC-coupled Output		0.06		°
Time Domain						
$t_R$ , $t_F$	Rise and Fall Time	$V_{OUT} = 0.2\text{V}$ step; (10% to 90%)		5		ns
$t_S$	Settling Time to 0.1%	$V_{OUT} = 1\text{V}$ step		25		ns
OS	Overshoot	$V_{OUT} = 0.2\text{V}$ step		8		%
SR	Slew Rate	$G = -1$ , $2\text{V}$ step		175		V/ $\mu\text{s}$
Distortion/Noise Response						
THD	Total Harmonic Distortion	1MHz, $V_{OUT} = 1V_{pp}$		75		dBc
$e_n$	Input Voltage Noise	>50kHz		16		nV/ $\sqrt{\text{Hz}}$
X <sub>TALK</sub>	Crosstalk	$f = 5\text{MHz}$		58		dB
DC Performance						
$V_{IO}$	Input Offset Voltage			0.5		mV
$d_{VIO}$	Average Drift			5		$\mu\text{V}/^\circ\text{C}$
$I_B$	Input Bias Current			1.4		$\mu\text{A}$
$dI_B$	Average Drift			2		nA/ $^\circ\text{C}$
$I_{OS}$	Input Offset Current			0.05		$\mu\text{A}$
PSRR	Power Supply Rejection Ratio	DC		102		dB
$A_{OL}$	Open Loop Gain	$R_L = 2\text{k}\Omega$		92		dB
$I_S$	Supply Current	per channel		2.6		mA
Input Characteristics						
$C_{IN}$	Input Capacitance			0.5		pF
CMIR	Common Mode Input Range			-0.3 to 2.1		V
CMRR	Common Mode Rejection Ratio	DC, $V_{CM} = 0$ to $1.5\text{V}$		100		dB
Output Characteristics						
$V_{OUT}$	Output Swing	$R_L = 150\Omega$		0.3 to 2.75		V
		$R_L = 2\text{k}\Omega$		0.02 to 2.96		V
$I_{OUT}$	Output Current			$\pm 100$		mA
$I_{SC}$	Short Circuit Current	$V_{OUT} = V_S / 2$		$\pm 125$		V
$V_S$	Power Supply Operating Range			2.7 to 12.6		V

## Electrical Characteristics at +5V

$T_A = 25^\circ\text{C}$ ,  $V_S = +5\text{V}$ ,  $R_f = 1.5\text{k}\Omega$ ,  $R_L = 2\text{k}\Omega$  to  $V_S/2$ ;  $G = 2$ ; unless otherwise noted.

Symbol	Parameter	Conditions	Min	Typ	Max	Units
Frequency Domain Response						
GBWP	-3dB Gain Bandwidth Product	$G = +11$ , $V_{OUT} = 0.2V_{pp}$		95		MHz
UGBW	Unity Gain Bandwidth	$V_{OUT} = 0.2V_{pp}$ , $R_F = 0$		250		MHz
BW <sub>SS</sub>	-3dB Bandwidth	$V_{OUT} = 0.2V_{pp}$		85		MHz
$f_{0.1dB}$	0.1dB Gain Flatness	$V_{OUT} = 0.2V_{pp}$ , $R_L = 150\Omega$		35		MHz
BW <sub>LS</sub>	Large Signal Bandwidth	$V_{OUT} = 2V_{pp}$		65		MHz
DG	Differential Gain	DC-coupled Output		0.03		%
		AC-coupled Output		0.04		%
DP	Differential Phase	DC-coupled Output		0.03		°
		AC-coupled Output		0.06		°
Time Domain						
$t_R$ , $t_F$	Rise and Fall Time	$V_{OUT} = 0.2\text{V}$ step		5		ns
$t_S$	Settling Time to 0.1%	$V_{OUT} = 2\text{V}$ step		25		ns
OS	Overshoot	$V_{OUT} = 0.2\text{V}$ step		5		%
SR	Slew Rate	$G = -1$ , $4\text{V}$ step		220		V/ $\mu\text{s}$
Distortion/Noise Response						
THD	Total Harmonic Distortion	1MHz, $V_{OUT} = 2V_{pp}$		-75		dBc
$e_n$	Input Voltage Noise	>50kHz		16		nV/ $\sqrt{\text{Hz}}$
X <sub>TALK</sub>	Crosstalk	$f = 5\text{MHz}$		58		dB
DC Performance						
$V_{IO}$	Input Offset Voltage		-7	0.5	7	mV
$d_{VIO}$	Average Drift			5		$\mu\text{V}/^\circ\text{C}$
$I_B$	Input Bias Current		-2	1.4	2	$\mu\text{A}$
$dI_B$	Average Drift			2		nA/ $^\circ\text{C}$
$I_{OS}$	Input Offset Current		-0.75	0.05	0.75	$\mu\text{A}$
PSRR	Power Supply Rejection Ratio	DC	80	102		dB
$A_{OL}$	Open Loop Gain	$R_L = 2\text{k}\Omega$	80	92		dB
$I_S$	Supply Current	per channel		2.6	4	mA
Input Characteristics						
$C_{IN}$	Input Capacitance			0.5		pF
CMIR	Common Mode Input Range			-0.3 to 4.1		V
CMRR	Common Mode Rejection Ratio	DC, $V_{CM} = 0$ to $3.5\text{V}$	75	100		dB
Output Characteristics						
$V_{OUT}$	Output Swing	$R_L = 150\Omega$	0.35	0.1 to 4.9	4.65	V
		$R_L = 2\text{k}\Omega$		0.03 to 4.95		V
$I_{OUT}$	Output Current			$\pm 100$		mA
$I_{SC}$	Short Circuit Current	$V_{OUT} = V_S / 2$		$\pm 125$		V
$V_S$	Power Supply Operating Range			2.7 to 12.6		V

## Electrical Characteristics at $\pm 5V$

$T_A = 25^\circ C$ ,  $V_S = \pm 5V$ ,  $R_f = 1.5k\Omega$ ,  $R_L = 2k\Omega$  to GND;  $G = 2$ ; unless otherwise noted.

Symbol	Parameter	Conditions	Min	Typ	Max	Units
Frequency Domain Response						
GBWP	-3dB Gain Bandwidth Product	$G = +11$ , $V_{OUT} = 0.2V_{pp}$		90		MHz
UGBW	Unity Gain Bandwidth	$V_{OUT} = 0.2V_{pp}$ , $R_F = 0$		260		MHz
BW <sub>SS</sub>	-3dB Bandwidth	$V_{OUT} = 0.2V_{pp}$		85		MHz
$f_{0.1dB}$	0.1dB Gain Flatness	$V_{OUT} = 0.2V_{pp}$ , $R_L = 150\Omega$		22		MHz
BW <sub>LS</sub>	Large Signal Bandwidth	$V_{OUT} = 2V_{pp}$		65		MHz
DG	Differential Gain	DC-coupled Output		0.03		%
		AC-coupled Output		0.04		%
DP	Differential Phase	DC-coupled Output		0.03		°
		AC-coupled Output		0.06		°
Time Domain						
$t_R$ , $t_F$	Rise and Fall Time	$V_{OUT} = 0.2V$ step		5		ns
$t_S$	Settling Time to 0.1%	$V_{OUT} = 2V$ step, $R_L = 100\Omega$		25		ns
OS	Overshoot	$V_{OUT} = 0.2V$ step		5		%
SR	Slew Rate	$G = -1$ , $5V$ step		225		V/ $\mu s$
Distortion/Noise Response						
THD	Total Harmonic Distortion	1MHz, $V_{OUT} = 2V_{pp}$		76		dBc
$e_n$	Input Voltage Noise	>50kHz		16		nV/ $\sqrt{Hz}$
X <sub>TALK</sub>	Crosstalk	$f = 5MHz$		58		dB
DC Performance						
$V_{IO}$	Input Offset Voltage			0.5		mV
$d_{VIO}$	Average Drift			5		$\mu V/^\circ C$
$I_B$	Input Bias Current			1.3		$\mu A$
$dI_B$	Average Drift			2		nA/ $^\circ C$
$I_{OS}$	Input Offset Current			0.04		$\mu A$
PSRR	Power Supply Rejection Ratio	DC		102		dB
$A_{OL}$	Open Loop Gain	$R_L = 2k\Omega$		92		dB
$I_S$	Supply Current	per channel		2.6		mA
Input Characteristics						
$C_{IN}$	Input Capacitance			0.5		pF
CMIR	Common Mode Input Range			-5.3 to 4.1		V
CMRR	Common Mode Rejection Ratio	DC, $V_{CM} = -5$ to $3.5V$		100		dB
Output Characteristics						
$V_{OUT}$	Output Swing	$R_L = 150\Omega$		-4.8 to 4.8		V
		$R_L = 2k\Omega$		-4.95 to 4.93		V
$I_{OUT}$	Output Current			$\pm 100$		mA
$I_{SC}$	Short Circuit Current	$V_{OUT} = V_S / 2$		$\pm 125$		V
$V_S$	Power Supply Operating Range			2.7 to 12.6		V

### CLC1007 Pin Configurations

#### TSOT-5

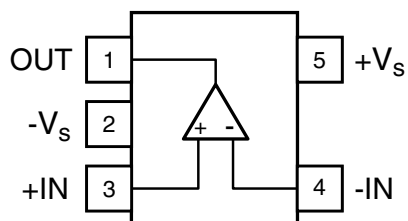

### CLC1007 Pin Assignments

#### TSOT-5

Pin No.	Pin Name	Description
1	OUT	Output
2	-V <sub>S</sub>	Negative supply
3	+IN	Positive input
4	-IN	Negative input
5	+V <sub>S</sub>	Positive supply

#### SOIC-8

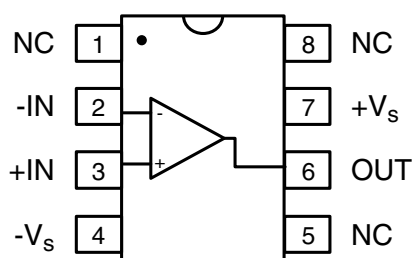

#### SOIC-8

Pin No.	Pin Name	Description
1	NC	No Connect
2	-IN	Negative input
3	+IN	Positive input
4	-V <sub>S</sub>	Negative supply
5	NC	No Connect
6	OUT	Output
7	+V <sub>S</sub>	Positive supply
8	NC	No Connect

### CLC2007 Pin Configuration

#### SOIC-8 / MSOP-8

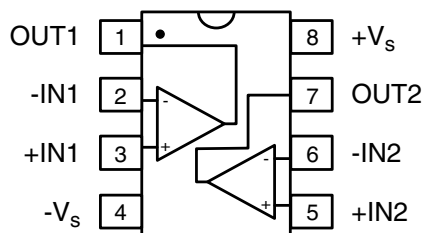

### CLC2007 Pin Assignments

#### SOIC-8 / MSOP-8

Pin No.	Pin Name	Description
1	OUT1	Output, channel 1
2	-IN1	Negative input, channel 1
3	+IN1	Positive input, channel 1
4	-V <sub>S</sub>	Negative supply
5	+IN2	Positive input, channel 2
6	-IN2	Negative input, channel 2
7	OUT2	Output, channel 2
8	+V <sub>S</sub>	Positive supply

**CLC4007 Pin Configuration**

SOIC-14 / TSSOP-14

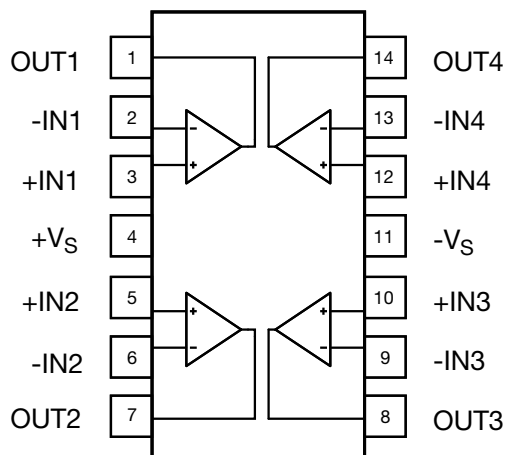

**CLC4007 Pin Assignments**

SOIC-14 / TSSOP-14

Pin No.	Pin Name	Description
1	OUT1	Output, channel 1
2	-IN1	Negative input, channel 1
3	+IN1	Positive input, channel 1
4	+V <sub>S</sub>	Positive supply
5	+IN2	Positive input, channel 2
6	-IN2	Negative input, channel 2
7	OUT2	Output, channel 2
8	OUT3	Output, channel 3
9	-IN3	Negative input, channel 3
10	+IN3	Positive input, channel 3
11	-V <sub>S</sub>	Negative supply
12	+IN4	Positive input, channel 4
13	-IN4	Negative input, channel 4
14	OUT4	Output, channel 4

**Typical Performance Characteristics at +3V**

$T_A = 25^\circ\text{C}$ ,  $V_S = +3\text{V}$ ,  $R_L = 2\text{k}\Omega$  to  $V_S/2$ ,  $G = +2$ ,  $R_F = 1.5\text{k}\Omega$ ; unless otherwise noted.

Non-Inverting Frequency Response

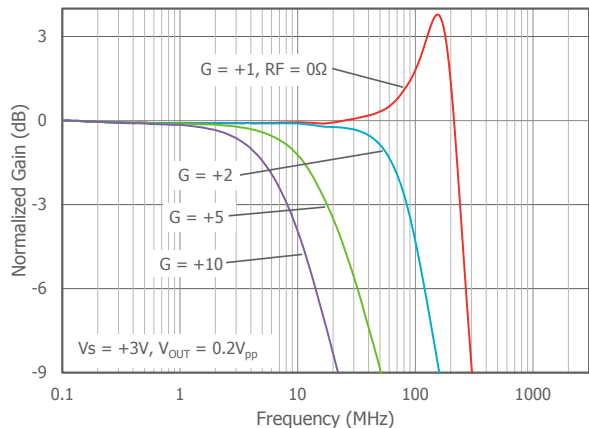

Inverting Frequency Response

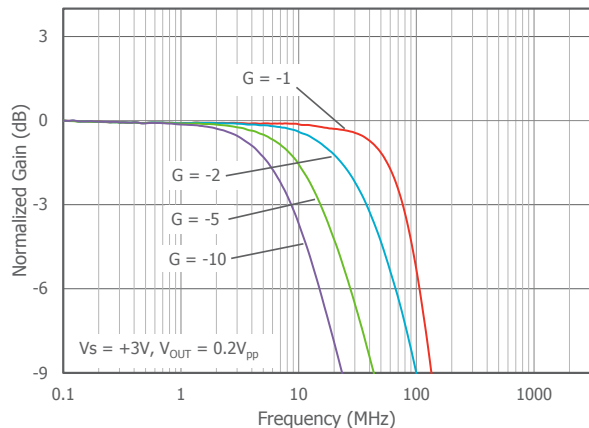

Frequency Response vs  $C_L$

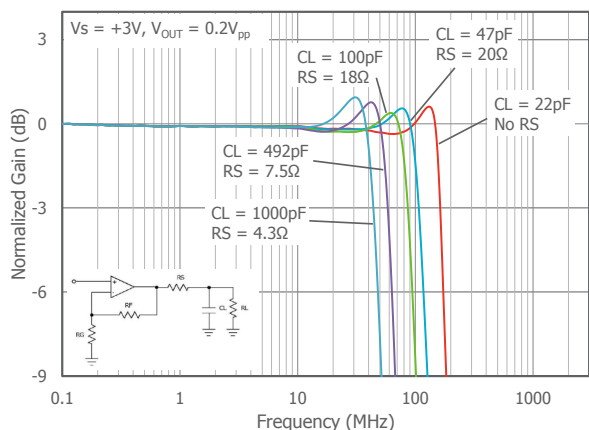

Frequency Response vs  $R_L$

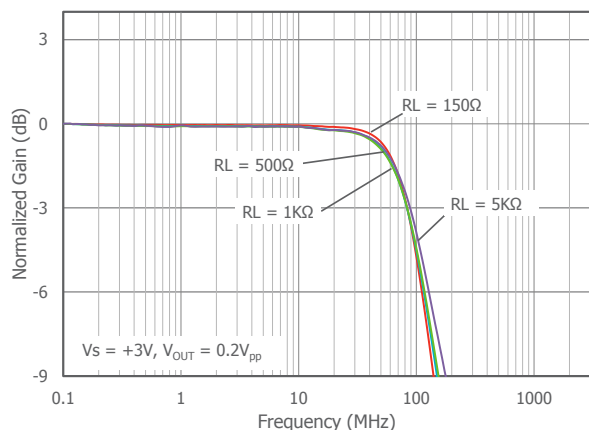

Large Signal Frequency Response

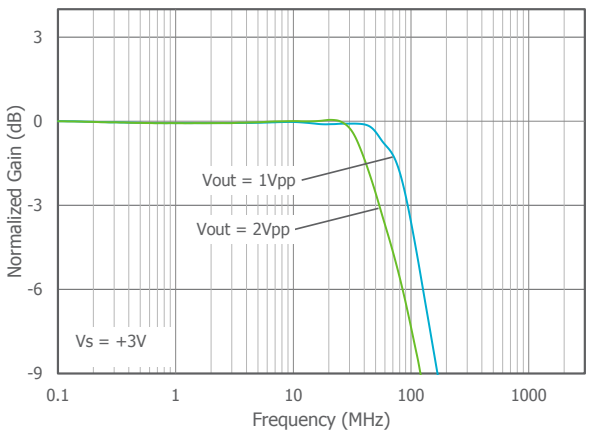

-3dB BW vs Output Voltage

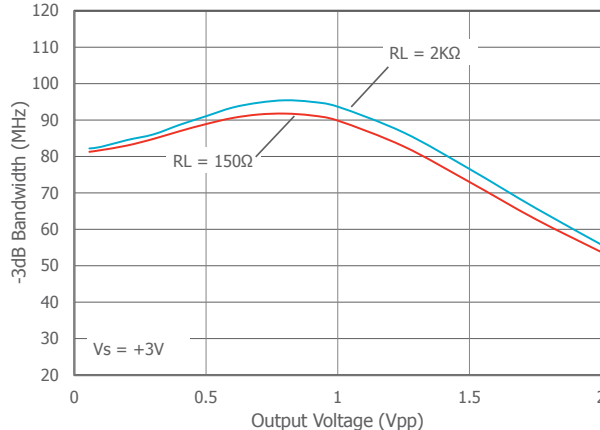



### Typical Performance Characteristics at +3V

$T_A = 25^\circ\text{C}$ ,  $V_S = +3\text{V}$ ,  $R_L = 2\text{k}\Omega$  to  $V_S/2$ ,  $G = +2$ ,  $R_F = 1.5\text{k}\Omega$ ; unless otherwise noted.

Input Voltage Noise vs Frequency

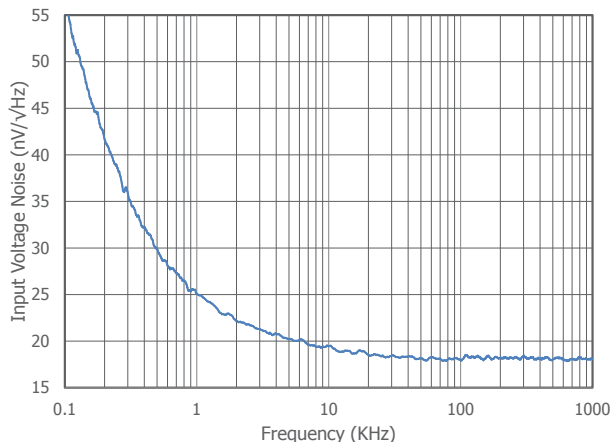

2nd Harmonic Distortion vs  $R_L$  over Frequency

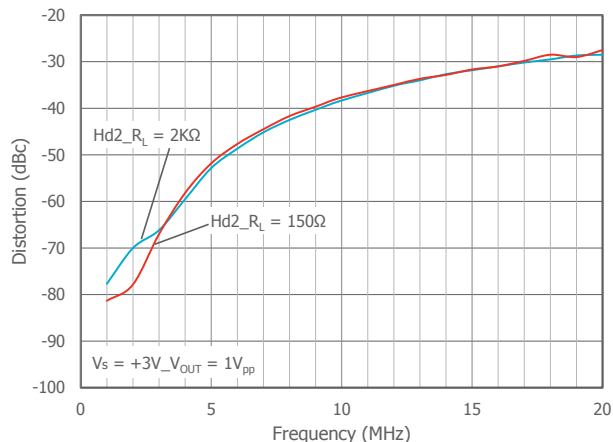

3rd Harmonic Distortion vs  $R_L$  over Frequency

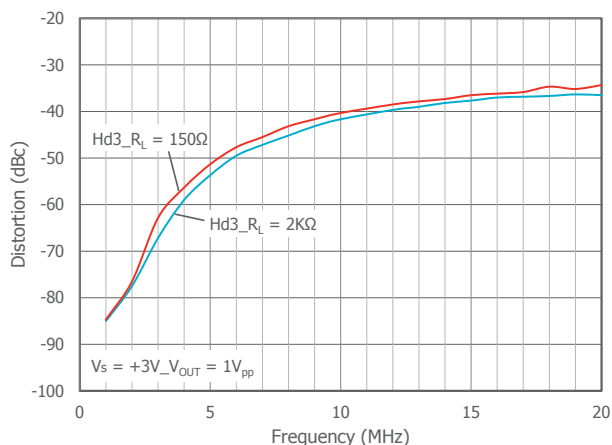

2nd Harmonic Distortion vs  $V_O$  over Frequency

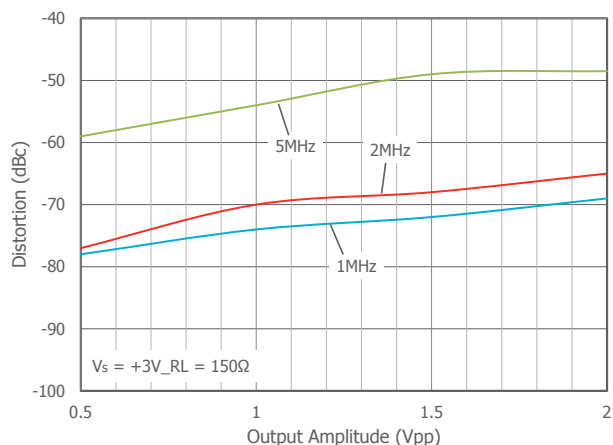

3rd Harmonic Distortion vs  $V_O$  over Frequency

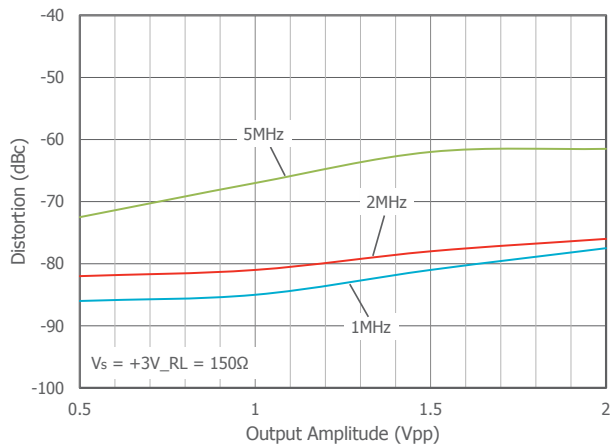

Non-Inverting Small Signal Pulse Response

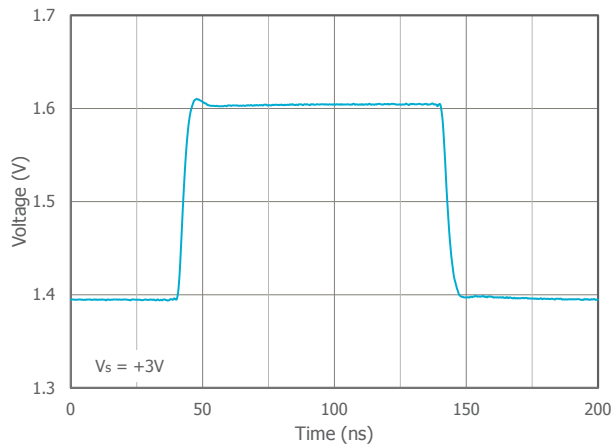

### Typical Performance Characteristics at +3V

$T_A = 25^\circ\text{C}$ ,  $V_S = +3\text{V}$ ,  $R_L = 2\text{k}\Omega$  to  $V_S/2$ ,  $G = +2$ ,  $R_F = 1.5\text{k}\Omega$ ; unless otherwise noted.

Non-Inverting Large Signal Pulse Response

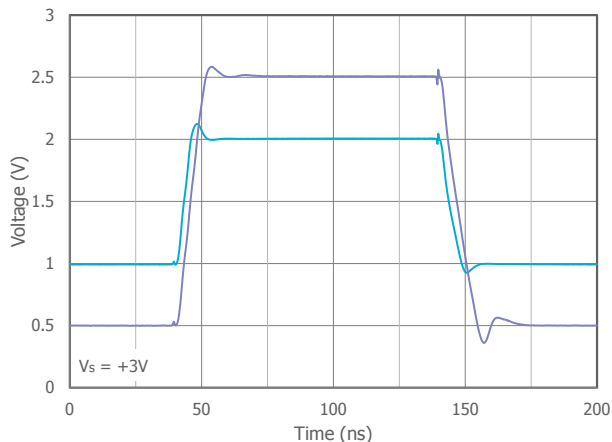

Crosstalk vs Frequency (CLC2007)

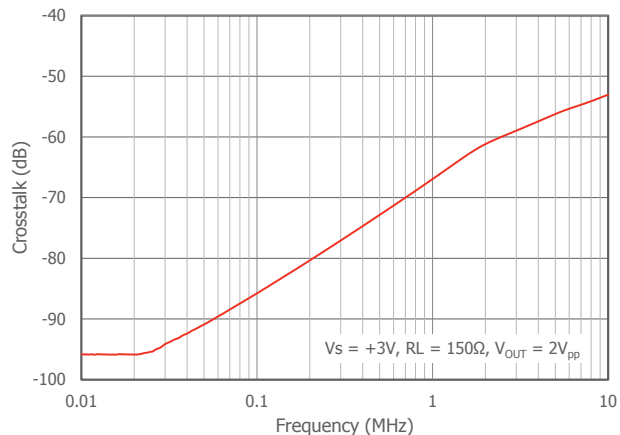

Differential Gain & Phase\_DC Coupled

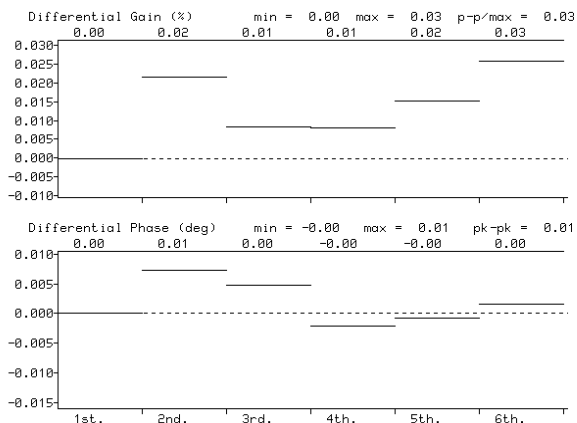

Differential Gain & Phase\_AC Coupled

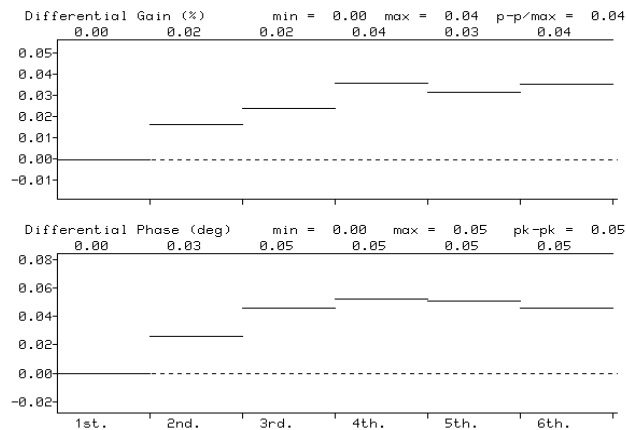

**Typical Performance Characteristics at +5V**

$T_A = 25^\circ\text{C}$ ,  $V_S = +5\text{V}$ ,  $R_L = 2\text{k}\Omega$  to  $V_S/2$ ,  $G = +2$ ,  $R_F = 1.5\text{k}\Omega$ ; unless otherwise noted.

Non-Inverting Frequency Response

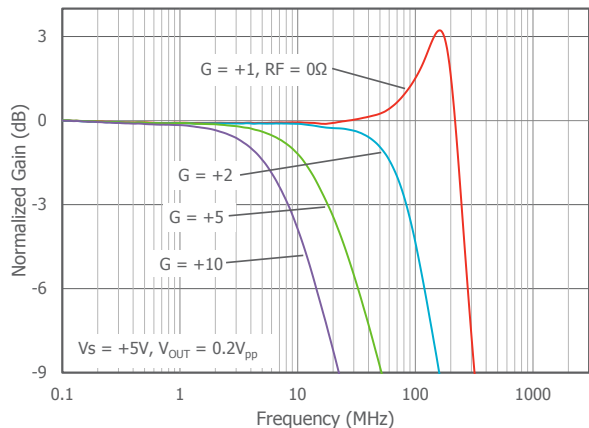

Inverting Frequency Response

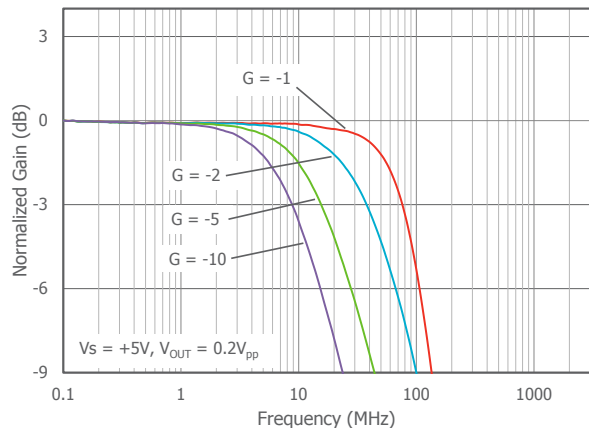

Frequency Response vs  $C_L$

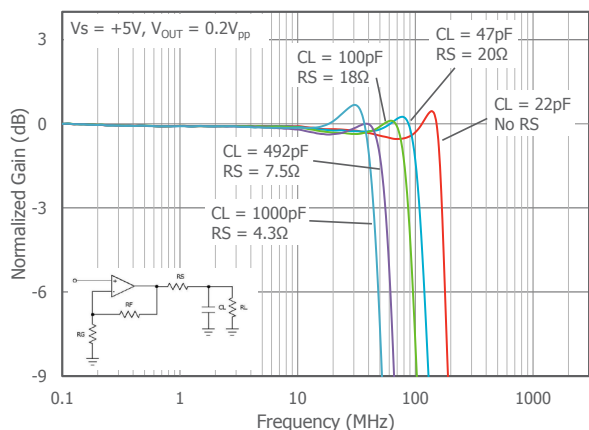

Frequency Response vs  $R_L$

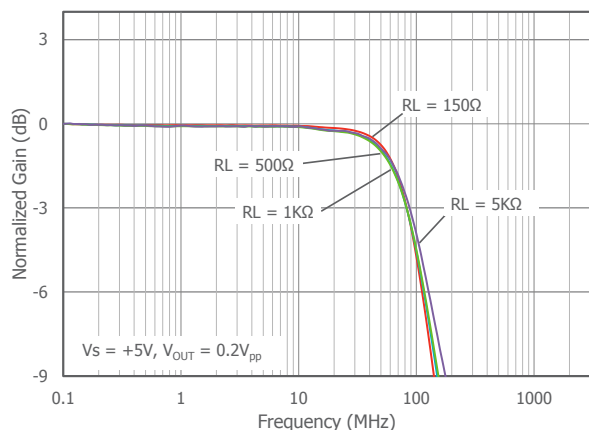

Large Signal Frequency Response

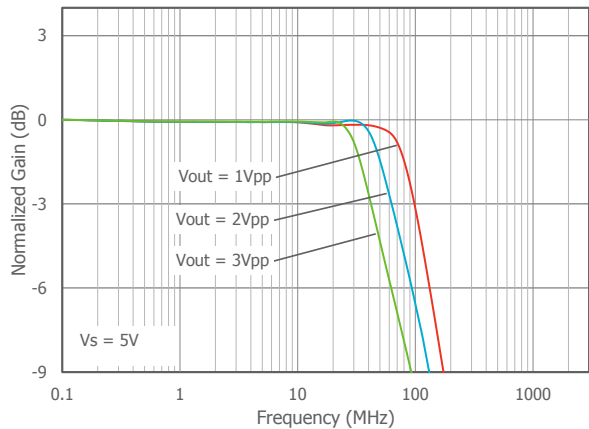

-3dB BW vs Output Voltage

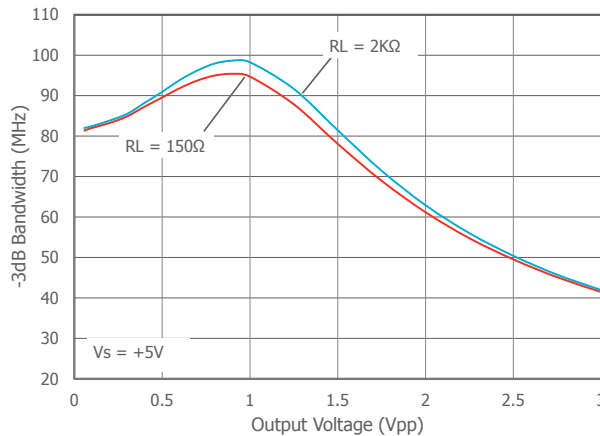

**Typical Performance Characteristics at +5V**

$T_A = 25^\circ\text{C}$ ,  $V_S = +5\text{V}$ ,  $R_L = 2\text{k}\Omega$  to  $V_S/2$ ,  $G = +2$ ,  $R_F = 1.5\text{k}\Omega$ ; unless otherwise noted.

Input Voltage Noise vs Frequency

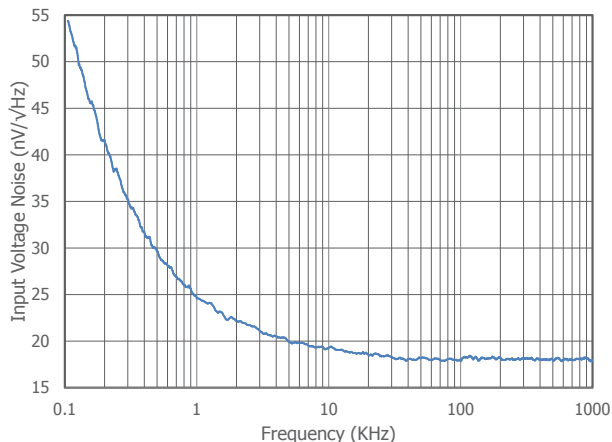

2nd Harmonic Distortion vs  $R_L$  over Frequency

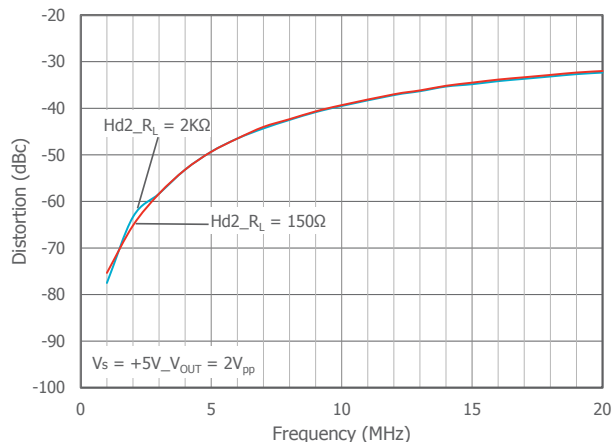

3rd Harmonic Distortion vs  $R_L$  over Frequency

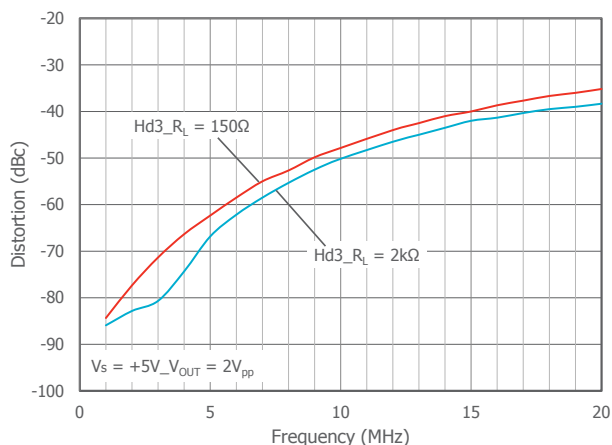

2nd Harmonic Distortion vs  $V_O$  over Frequency

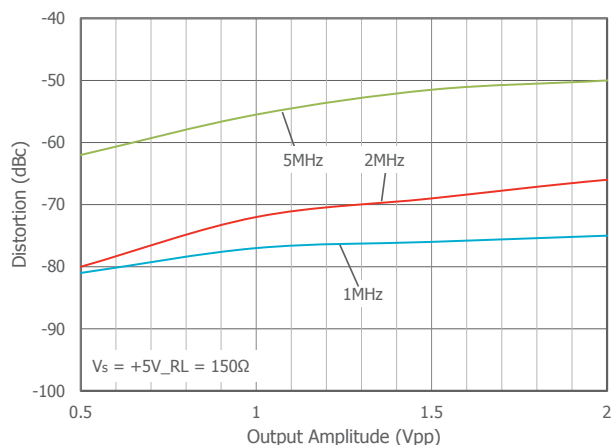

3rd Harmonic Distortion vs  $V_O$  over Frequency

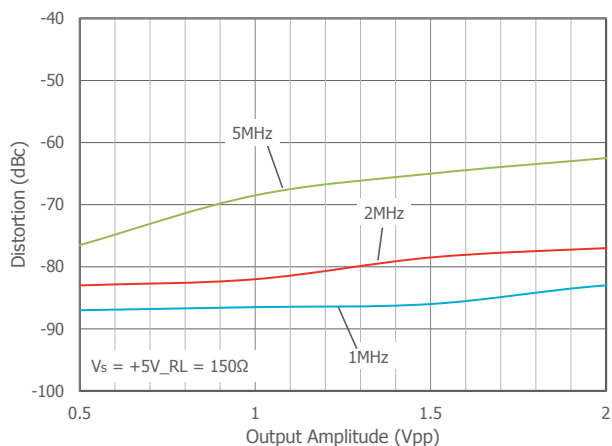

Non-Inverting Small Signal Pulse Response

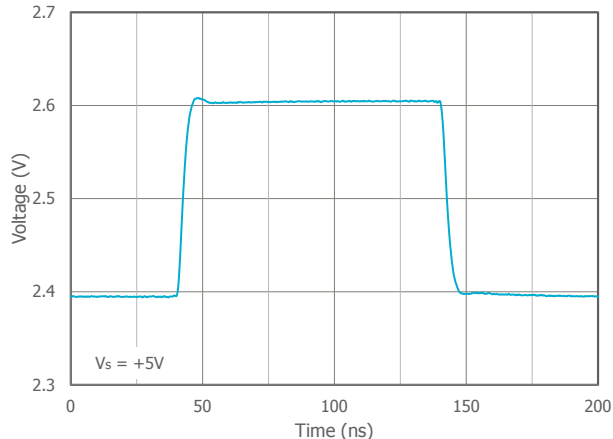

**Typical Performance Characteristics at +5V**

$T_A = 25^\circ\text{C}$ ,  $V_S = +5\text{V}$ ,  $R_L = 2\text{k}\Omega$  to  $V_S/2$ ,  $G = +2$ ,  $R_F = 1.5\text{k}\Omega$ ; unless otherwise noted.

Non-Inverting Large Signal Pulse Response

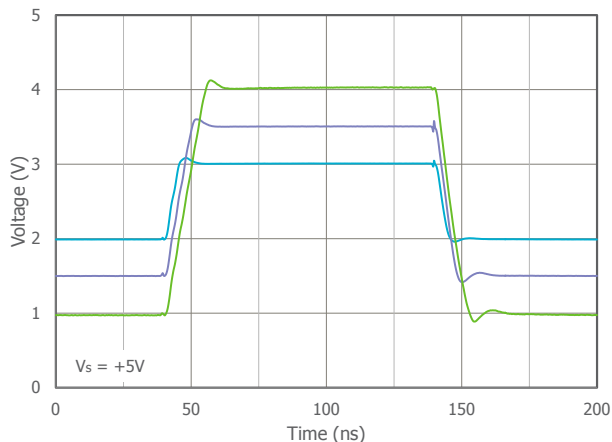

Crosstalk vs Frequency (CLC2007)

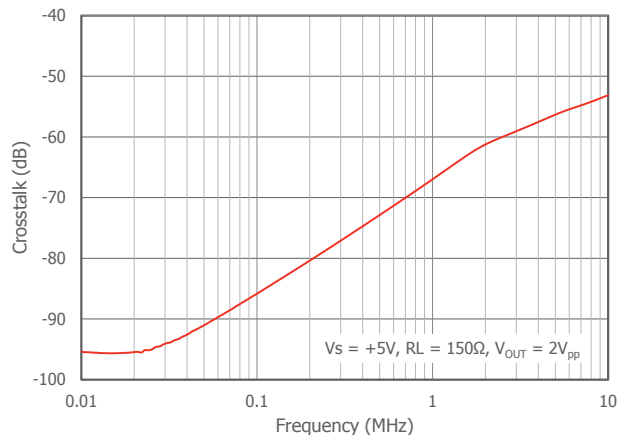

Differential Gain & Phase\_DC Coupled

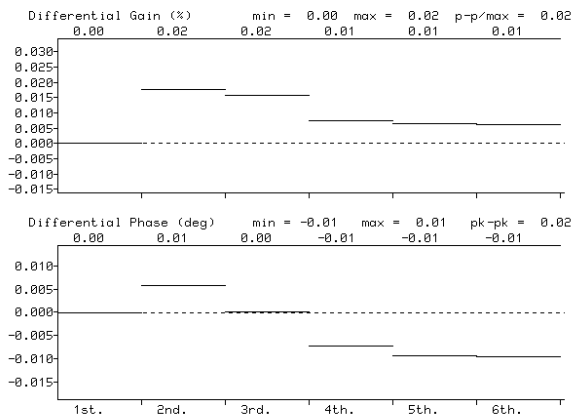

Differential Gain & Phase\_AC Coupled

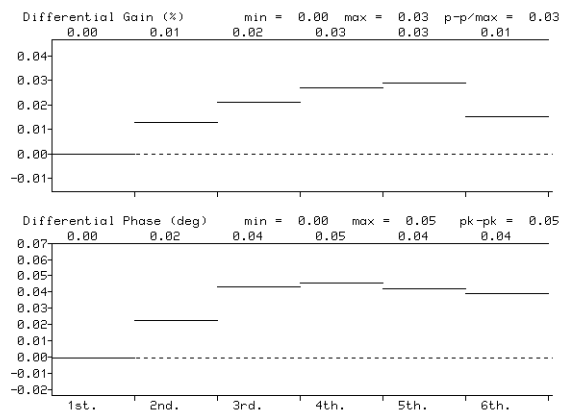

**Typical Performance Characteristics at ±5V**

$T_A = 25^\circ\text{C}$ ,  $V_S = \pm 5\text{V}$ ,  $R_L = 2\text{k}\Omega$  to GND,  $G = +2$ ,  $R_F = 1.5\text{k}\Omega$ ; unless otherwise noted.

**Non-Inverting Frequency Response**

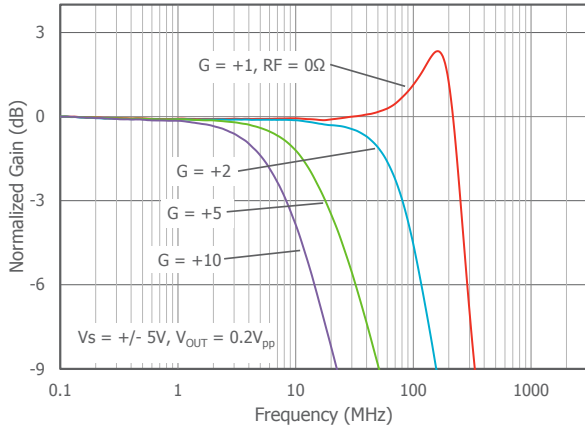

**Inverting Frequency Response**

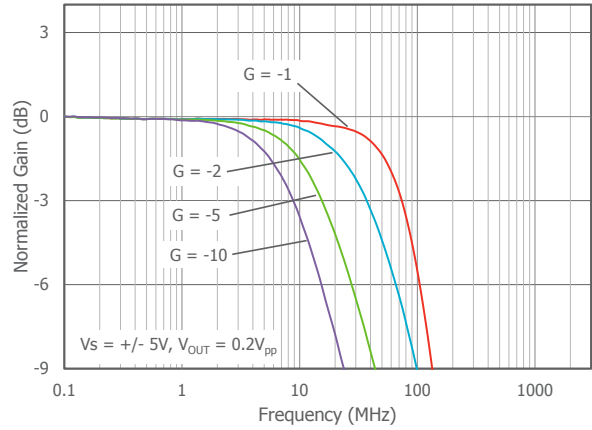

**Frequency Response vs  $C_L$**

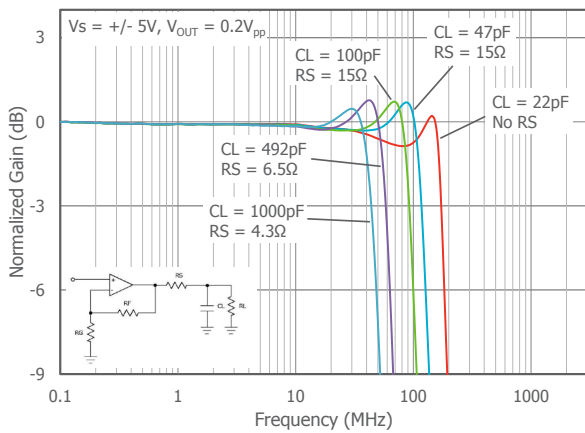

**Frequency Response vs  $R_L$**

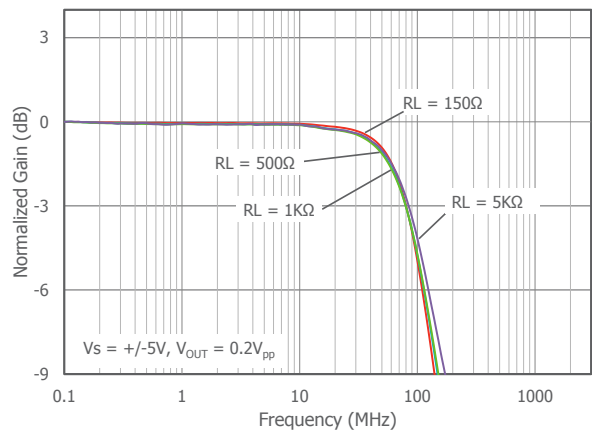

**Large Signal Frequency Response**

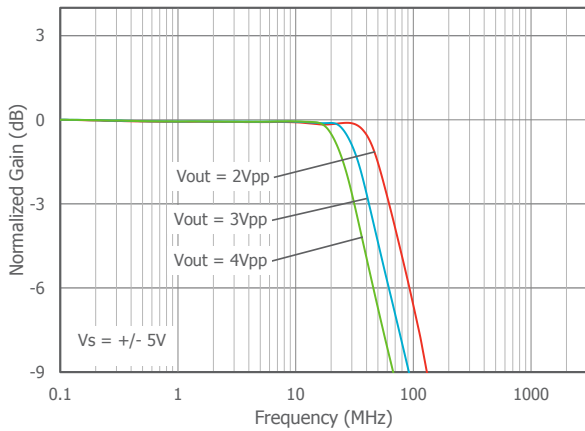

**-3dB BW vs Output Voltage**

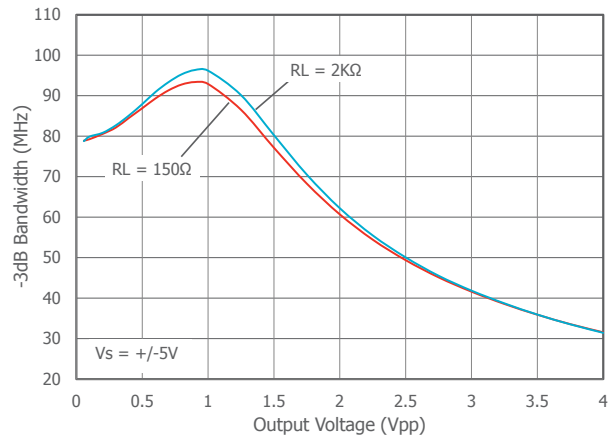

**Typical Performance Characteristics at ±5V**

$T_A = 25^\circ\text{C}$ ,  $V_S = \pm 5\text{V}$ ,  $R_L = 2\text{k}\Omega$  to GND,  $G = +2$ ,  $R_F = 1.5\text{k}\Omega$ ; unless otherwise noted.

Input Voltage Noise vs Frequency

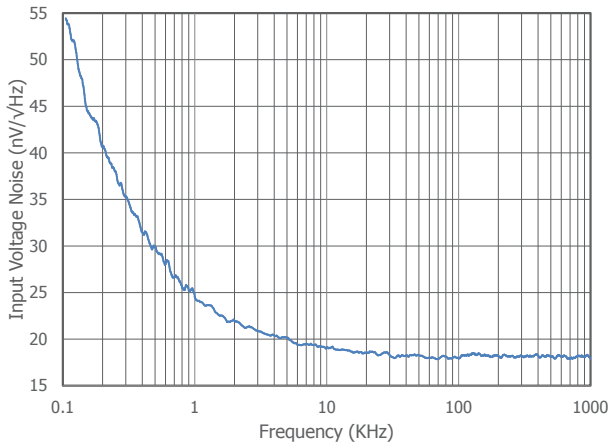

2nd Harmonic Distortion vs  $R_L$  over Frequency

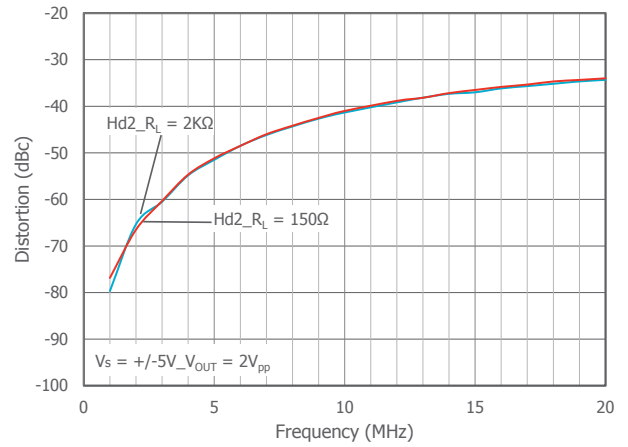

3rd Harmonic Distortion vs  $R_L$  over Frequency

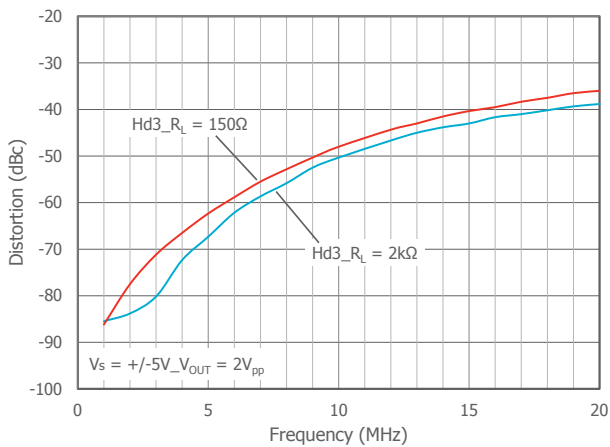

2nd Harmonic Distortion vs  $V_O$  over Frequency

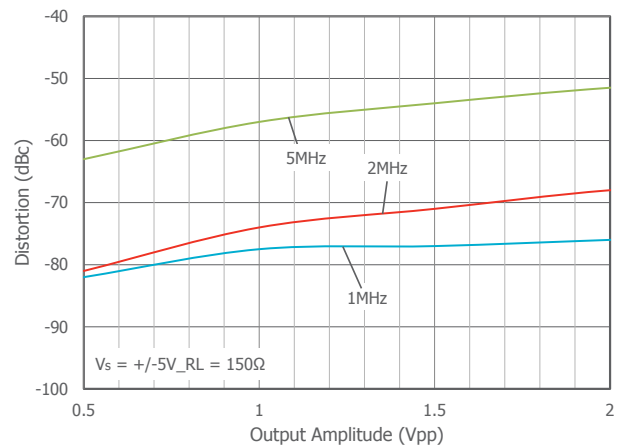

3rd Harmonic Distortion vs  $V_O$  over Frequency

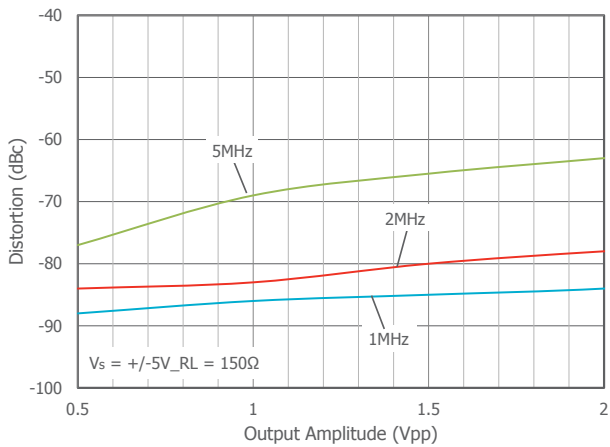

Non-Inverting Small Signal Pulse Response

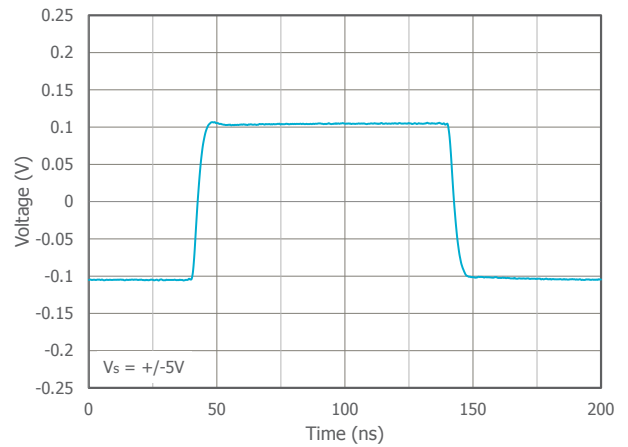

**Typical Performance Characteristics at ±5V**

$T_A = 25^\circ\text{C}$ ,  $V_S = \pm 5\text{V}$ ,  $R_L = 2\text{k}\Omega$  to GND,  $G = +2$ ,  $R_F = 1.5\text{k}\Omega$ ; unless otherwise noted.

Non-Inverting Large Signal Pulse Response

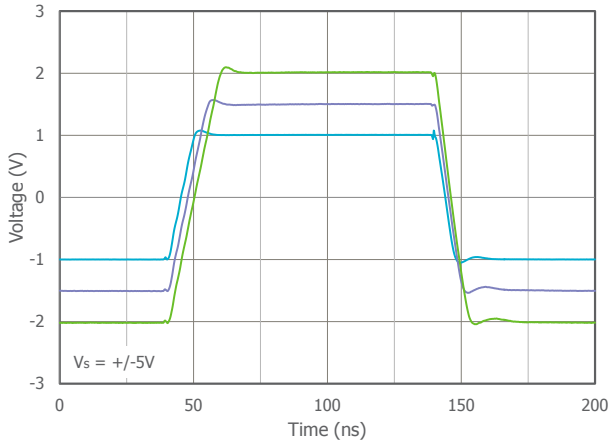

Crosstalk vs Frequency (CLC2007)

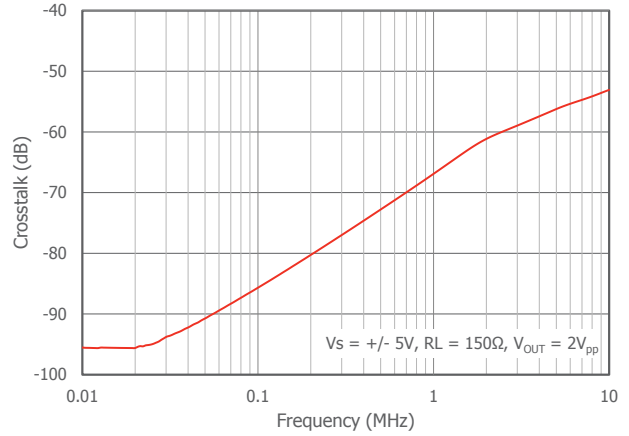

Differential Gain & Phase\_DC Coupled

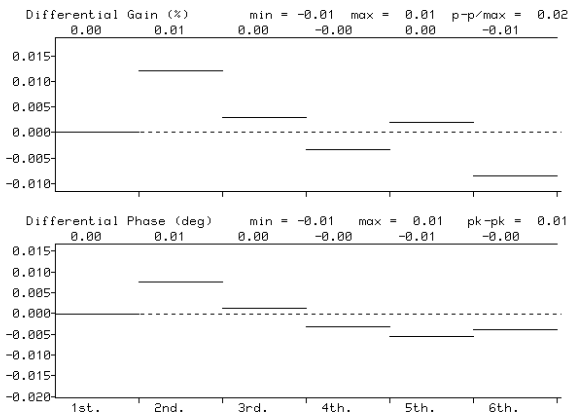

Differential Gain & Phase\_AC Coupled

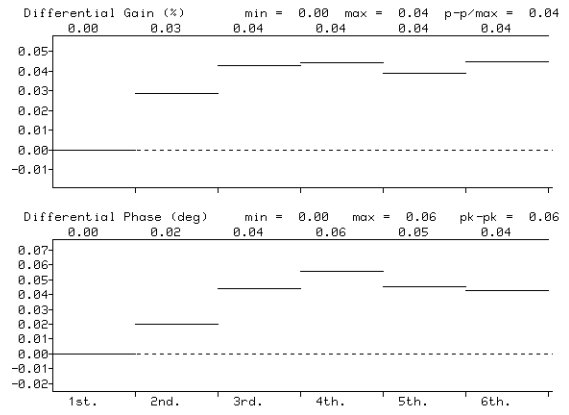



## Application Information

### General Description

The CLC1007, CLC2007, and CLC4007 are single supply, general purpose, voltage-feedback amplifiers fabricated on a complementary bipolar process using a patent pending topography. They feature a rail-to-rail output stage and is unity gain stable. Both gain bandwidth and slew rate are insensitive to temperature.

The common mode input range extends to 300mV below ground and to 0.9V below  $V_s$ . Exceeding these values will not cause phase reversal. However, if the input voltage exceeds the rails by more than 0.5V, the input ESD devices will begin to conduct. The output will stay at the rail during this overdrive condition.

The design is short circuit protected and offers “soft” saturation protection that improves recovery time.

Figures 1, 2, and 3 illustrate typical circuit configurations for non-inverting, inverting, and unity gain topologies for dual supply applications. They show the recommended bypass capacitor values and overall closed loop gain equations. Figure 4 shows the typical non-inverting gain circuit for single supply applications.

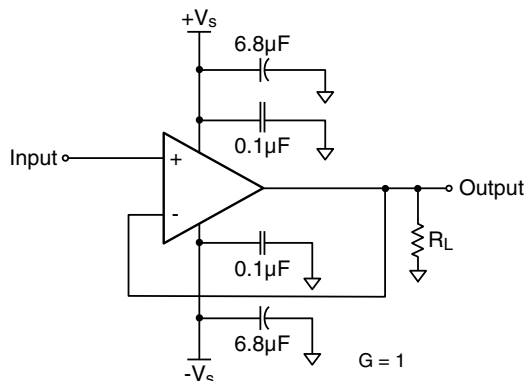

Figure 3: Unity Gain Circuit

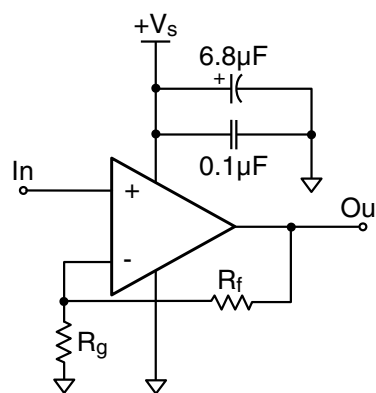

Figure 4: Single Supply Non-Inverting Gain Circuit

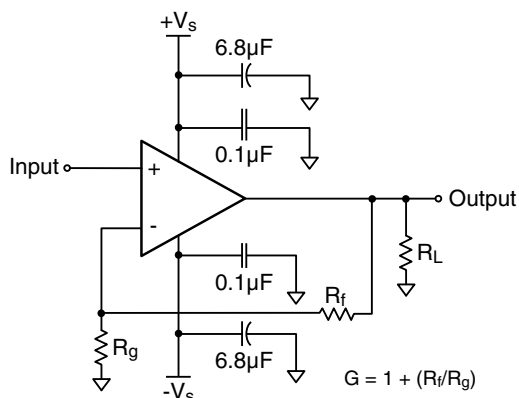

Figure 1: Typical Non-Inverting Gain Circuit

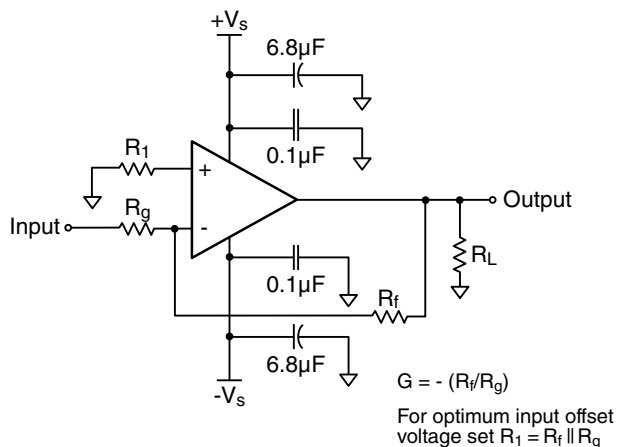

Figure 2: Typical Inverting Gain Circuit

### Overdrive Recovery

For an amplifier, an overdrive condition occurs when the output and/or input ranges are exceeded. The recovery time varies based on whether the input or output is overdriven and by how much the ranges are exceeded. The CLC1007, CLC2007, and CLC4007 will typically recover in less than 20ns from an overdrive condition. Figure 5 shows the CLC2007 in an overdriven condition.

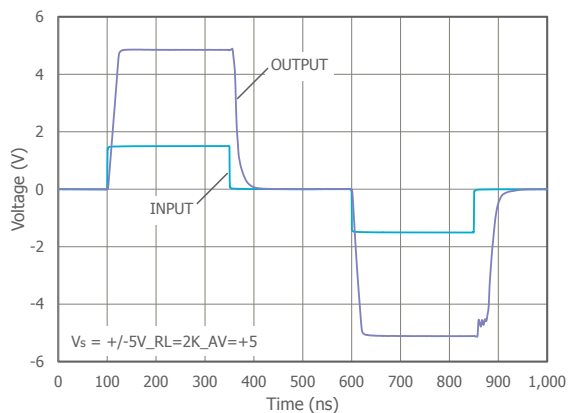

Figure 5: Overdrive Recovery

### Power Dissipation

Power dissipation should not be a factor when operating under the stated 2kΩ load condition. However, applications with low impedance, DC coupled loads should be analyzed to ensure that maximum allowed junction temperature is not exceeded. Guidelines listed below can be used to verify that the particular application will not cause the device to operate beyond its intended operating range.

Maximum power levels are set by the absolute maximum junction rating of 170°C. To calculate the junction temperature, the package thermal resistance value  $\theta_{JA}$  ( $\theta_{JA}$ ) is used along with the total die power dissipation.

$$T_{\text{Junction}} = T_{\text{Ambient}} + (\theta_{JA} \times P_D)$$

Where  $T_{\text{Ambient}}$  is the temperature of the working environment.

In order to determine  $P_D$ , the power dissipated in the load needs to be subtracted from the total power delivered by the supplies.

$$P_D = P_{\text{Supply}} - P_{\text{Load}}$$

Supply power is calculated by the standard power equation.

$$P_{\text{Supply}} = V_{\text{Supply}} \times I_{\text{RMSSupply}}$$

$$V_{\text{Supply}} = V_{S+} - V_{S-}$$

Power delivered to a purely resistive load is:

$$P_{\text{Load}} = ((V_{\text{Load}})_{\text{RMS}})^2 / R_{\text{LoadEff}}$$

The effective load resistor ( $R_{\text{LoadEff}}$ ) will need to include the effect of the feedback network. For instance,

$R_{\text{LoadEff}}$  in Figure 3 would be calculated as:

$$R_L \parallel (R_f + R_g)$$

These measurements are basic and are relatively easy to perform with standard lab equipment. For design purposes however, prior knowledge of actual signal levels and load impedance is needed to determine the dissipated power. Here,  $P_D$  can be found from

$$P_D = P_{\text{Quiescent}} + P_{\text{Dynamic}} - P_{\text{Load}}$$

Quiescent power can be derived from the specified  $I_S$  values along with known supply voltage,  $V_{\text{Supply}}$ . Load power can be calculated as above with the desired signal amplitudes using:

$$(V_{\text{Load}})_{\text{RMS}} = V_{\text{peak}} / \sqrt{2}$$

$$(I_{\text{Load}})_{\text{RMS}} = (V_{\text{Load}})_{\text{RMS}} / R_{\text{LoadEff}}$$

The dynamic power is focused primarily within the output stage driving the load. This value can be calculated as:

$$P_{\text{Dynamic}} = (V_{S+} - V_{\text{Load}})_{\text{RMS}} \times (I_{\text{Load}})_{\text{RMS}}$$

Assuming the load is referenced in the middle of the power rails or  $V_{\text{Supply}}/2$ .

The CLC1007 is short circuit protected. However, this may not guarantee that the maximum junction temperature (+150°C) is not exceeded under all conditions. Figure 6 shows the maximum safe power dissipation in the package vs. the ambient temperature for the packages available.

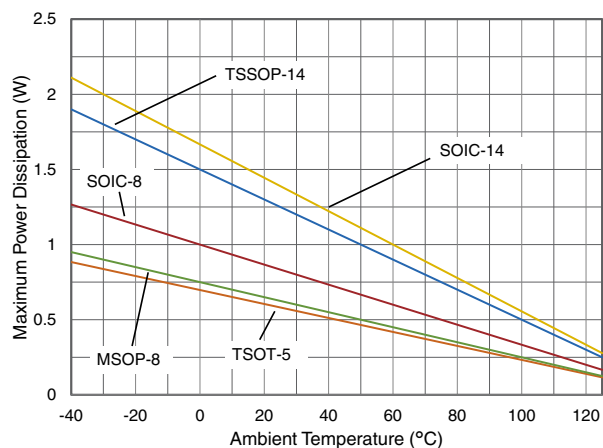

Figure 6. Maximum Power Derating

### Driving Capacitive Loads

Increased phase delay at the output due to capacitive loading can cause ringing, peaking in the frequency response, and possible unstable behavior. Use a series resistance,  $R_S$ , between the amplifier and the load to help improve stability and settling performance. Refer to Figure 7.

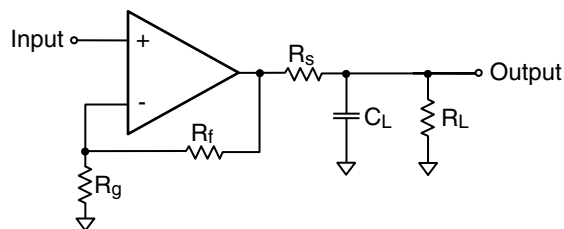

Figure 7. Addition of  $R_S$  for Driving Capacitive Loads

Table 1 provides the recommended  $R_S$  for various capacitive loads. The recommended  $R_S$  values result in approximately <1dB peaking in the frequency response.

$C_L$ (pF)	$R_S$ ( $\Omega$ )	-3dB BW (MHz)
22pF	0	118
47pF	15	112
100pF	15	91
492pF	6.5	59

Table 1: Recommended  $R_S$  vs.  $C_L$

For a given load capacitance, adjust  $R_S$  to optimize the tradeoff between settling time and bandwidth. In general, reducing  $R_S$  will increase bandwidth at the expense of additional overshoot and ringing.

## Layout Considerations

General layout and supply bypassing play major roles in high frequency performance. Exar has evaluation boards to use as a guide for high frequency layout and as an aid in device testing and characterization. Follow the steps below as a basis for high frequency layout:

- Include 6.8 $\mu$ F and 0.1 $\mu$ F ceramic capacitors for power supply decoupling
- Place the 6.8 $\mu$ F capacitor within 0.75 inches of the power pin
- Place the 0.1 $\mu$ F capacitor within 0.1 inches of the power pin
- Remove the ground plane under and around the part, especially near the input and output pins to reduce parasitic capacitance
- Minimize all trace lengths to reduce series inductances

Refer to the evaluation board layouts below for more information.

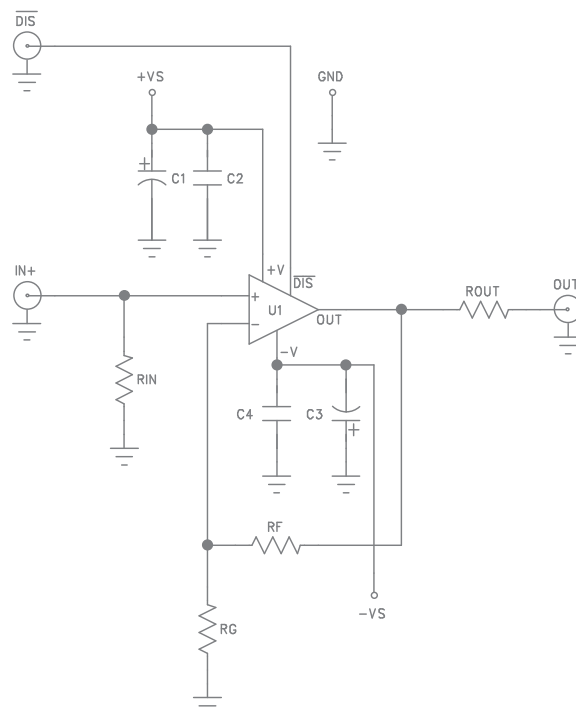

Figure 8. CEB002 & CEB003 Schematic

## Evaluation Board Information

The following evaluation boards are available to aid in the testing and layout of these devices:

Evaluation Board #	Products
CEB002	CLC1007 in TSOT
CEB003	CLC1007 in SOIC
CEB006	CLC2007 in SOIC
CEB010	CLC2007 in MSOP
CEB018	CLC4007 in SOIC
CEB019	CLC4007 in TSSOP

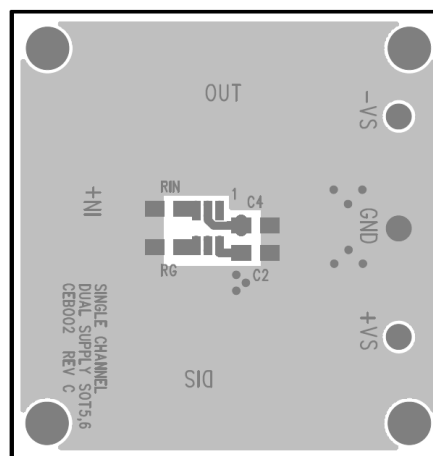

Figure 9. CEB002 Top View

## Evaluation Board Schematics

Evaluation board schematics and layouts are shown in Figures 8-20. These evaluation boards are built for dual-supply operation. Follow these steps to use the board in a single-supply application:

1. Short  $-V_S$  to ground.
2. Use C3 and C4, if the  $-V_S$  pin of the amplifier is not directly connected to the ground plane.

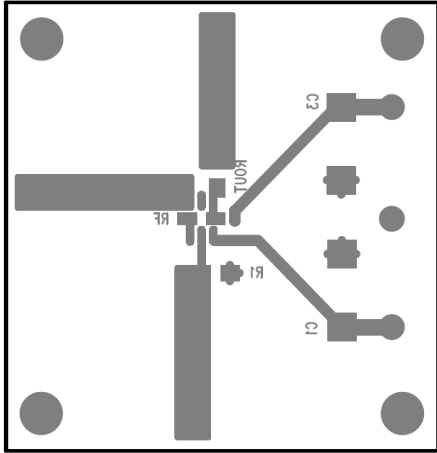

Figure 10. CEB002 Bottom View

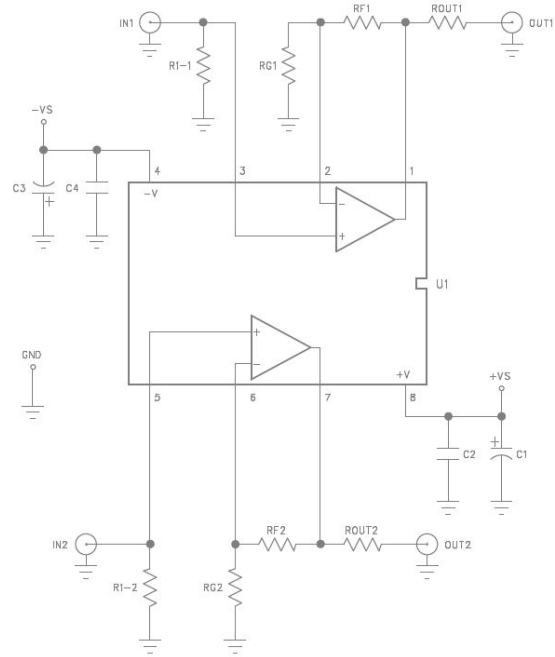

Figure 13. CEB006 & CEB010 Schematic

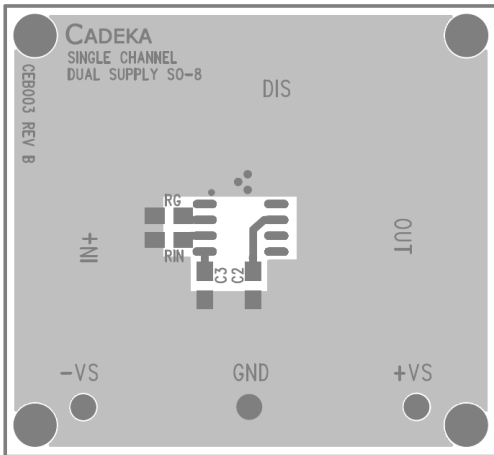

Figure 11. CEB003 Top View

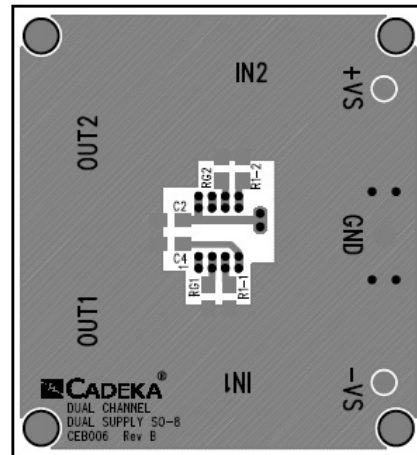

Figure 14. CEB006 Top View

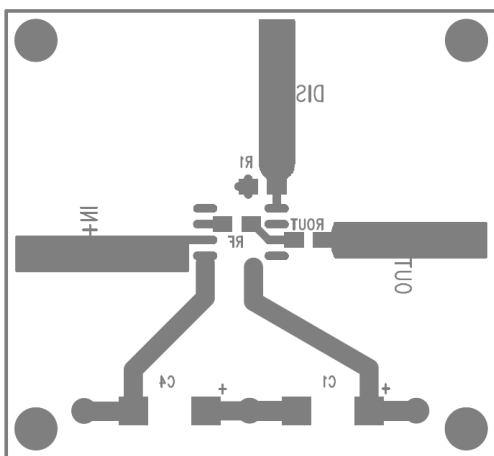

Figure 12. CEB003 Bottom View

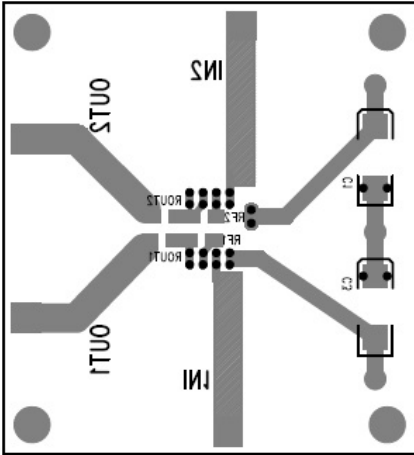

Figure 15. CEB006 Bottom View

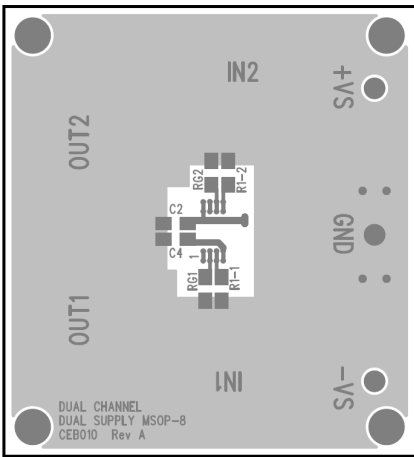

Figure 16. CEB010 Top View

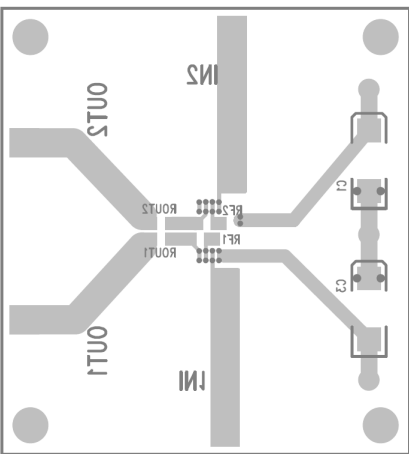

Figure 17. CEB010 Bottom View

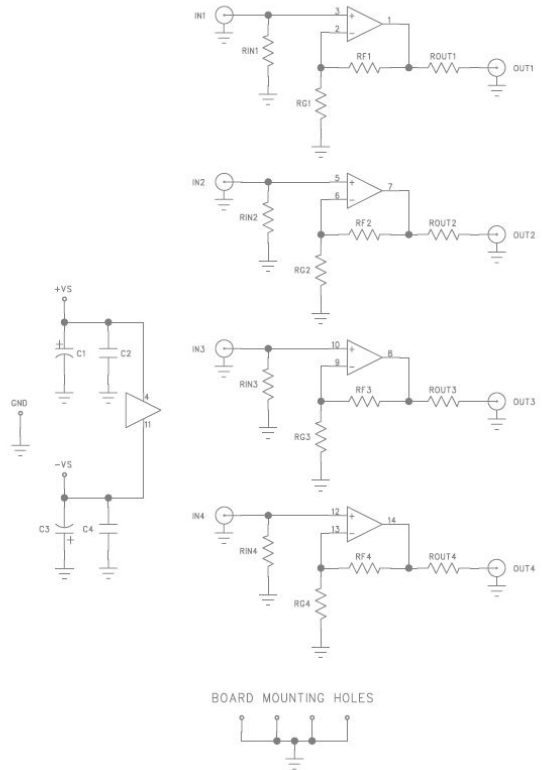

Figure 18. CEB018 Schematic

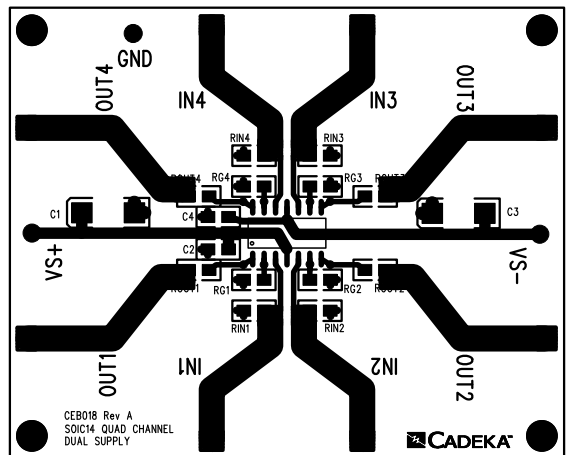

Figure 19. CEB018 Top View

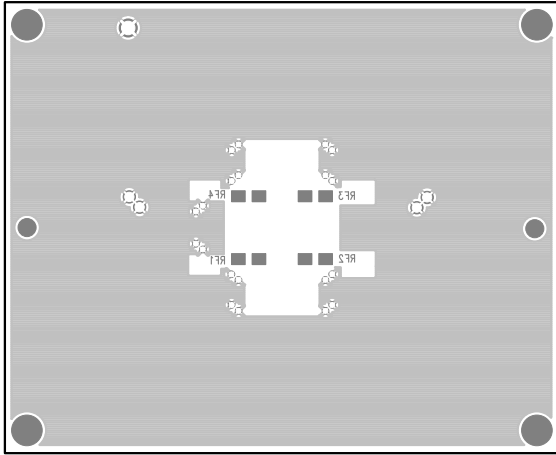
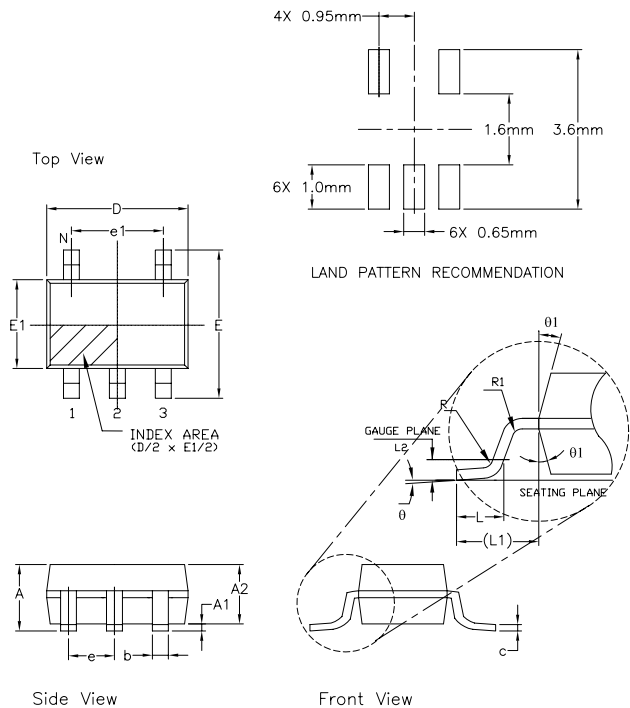

Figure 20. CEB018 Bottom View

## Mechanical Dimensions

### TSOT-5 Package



5 Pin TSOT (OPTION 2)						
SYMBOLS	DIMENSION IN MM (Control Unit)			DIMENSION IN INCH (Reference Unit)		
	MIN	NOM	MAX	MIN	NOM	MAX
A	0.75	—	0.80	0.030	—	0.031
A1	0.00	—	0.05	0.000	—	0.002
A2	0.70	0.75	0.78	0.028	0.030	0.031
b	0.35	—	0.50	0.012	—	0.020
c	0.10	—	0.20	0.003	—	0.008
D	2.90 BSC			0.114 BSC		
E	2.80 BSC			0.110 BSC		
E1	1.60 BSC			0.063 BSC		
e	0.95 BSC			0.038 BSC		
e1	1.90 BSC			0.075 BSC		
L	0.37	0.45	0.60	0.012	0.018	0.024
L1	0.60 REF			0.024 REF		
L2	0.25 BSC			0.010 BSC		
R	0.10	—	—	0.004	—	—
R1	0.10	—	0.25	0.004	—	0.010
theta	0°	4°	8°	0°	4°	8°
theta1	4°	10°	12°	4°	10°	12°
N	5			5		

### MSOP-8 Package

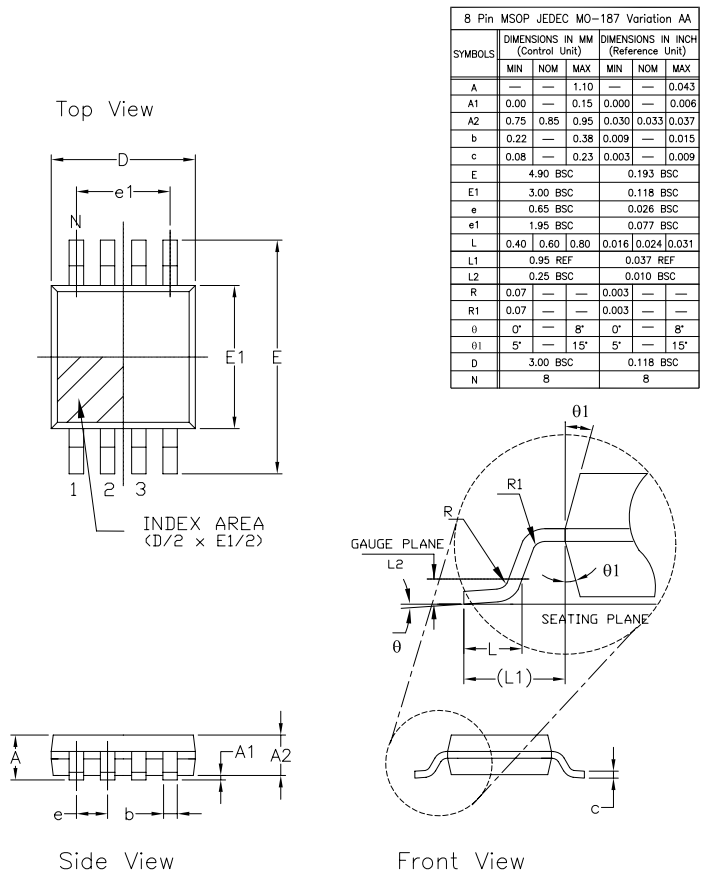

8 Pin MSOP JEDEC MO-187 Variation AA						
SYMBOLS	DIMENSIONS IN MM (Control Unit)			DIMENSIONS IN INCH (Reference Unit)		
	MIN	NOM	MAX	MIN	NOM	MAX
A	—	—	1.10	—	—	0.043
A1	0.00	—	0.15	0.000	—	0.006
A2	0.75	0.85	0.95	0.030	0.033	0.037
b	0.22	—	0.38	0.009	—	0.015
c	0.08	—	0.23	0.003	—	0.009
E	4.90 BSC			0.193 BSC		
E1	3.00 BSC			0.118 BSC		
e	0.65 BSC			0.026 BSC		
e1	1.95 BSC			0.077 BSC		
L	0.40	0.60	0.80	0.016	0.024	0.031
L1	0.95 REF			0.037 REF		
L2	0.25 BSC			0.010 BSC		
R	0.07	—	—	0.003	—	—
R1	0.07	—	—	0.003	—	—
theta	0°	—	8°	0°	—	8°
theta1	5°	—	15°	5°	—	15°
D	3.00 BSC			0.118 BSC		
N	8			8		

SOIC-8 Package

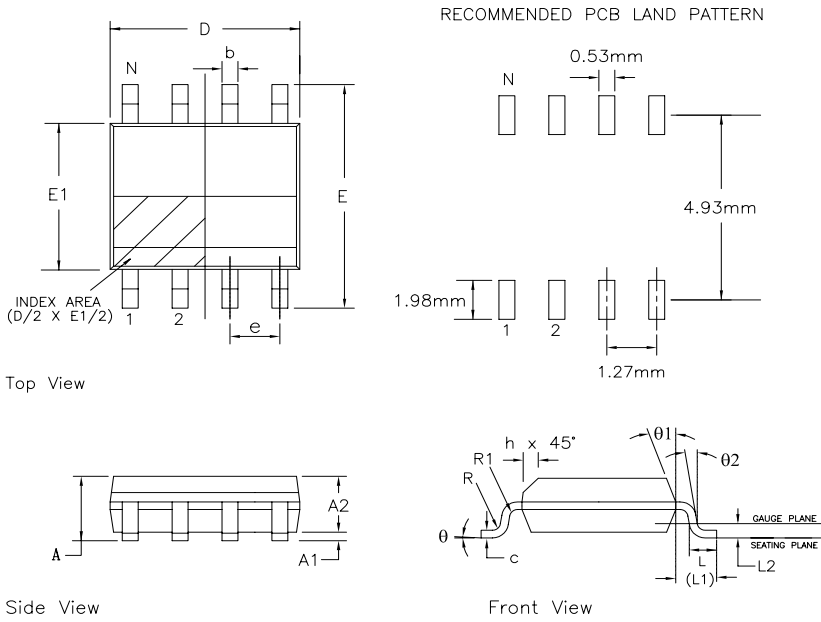

8 Pin SOICN JEDEC MS-012 Variation AA						
SYMBOLS	DIMENSIONS IN MM (Control Unit)			DIMENSIONS IN INCH (Reference Unit)		
	MIN	NOM	MAX	MIN	NOM	MAX
A	1.35	—	1.75	0.053	—	0.069
A1	0.10	—	0.25	0.004	—	0.010
A2	1.25	—	1.65	0.049	—	0.065
b	0.31	—	0.51	0.012	—	0.020
c	0.17	—	0.25	0.007	—	0.010
E	6.00 BSC			0.236 BSC		
E1	3.90 BSC			0.154 BSC		
e	1.27 BSC			0.050 BSC		
h	0.25	—	0.50	0.010	—	0.020
L	0.40	—	1.27	0.016	—	0.050
L1	1.04 REF			0.041 REF		
L2	0.25 BSC			0.010 BSC		
R	0.07	—	—	0.003	—	—
R1	0.07	—	—	0.003	—	—
theta	0°	—	8°	0°	—	8°
theta1	5°	—	15°	5°	—	15°
theta2	0°	—	—	0°	—	—
D	4.90 BSC			0.193 BSC		
N	8			8		

SOIC-14 Package

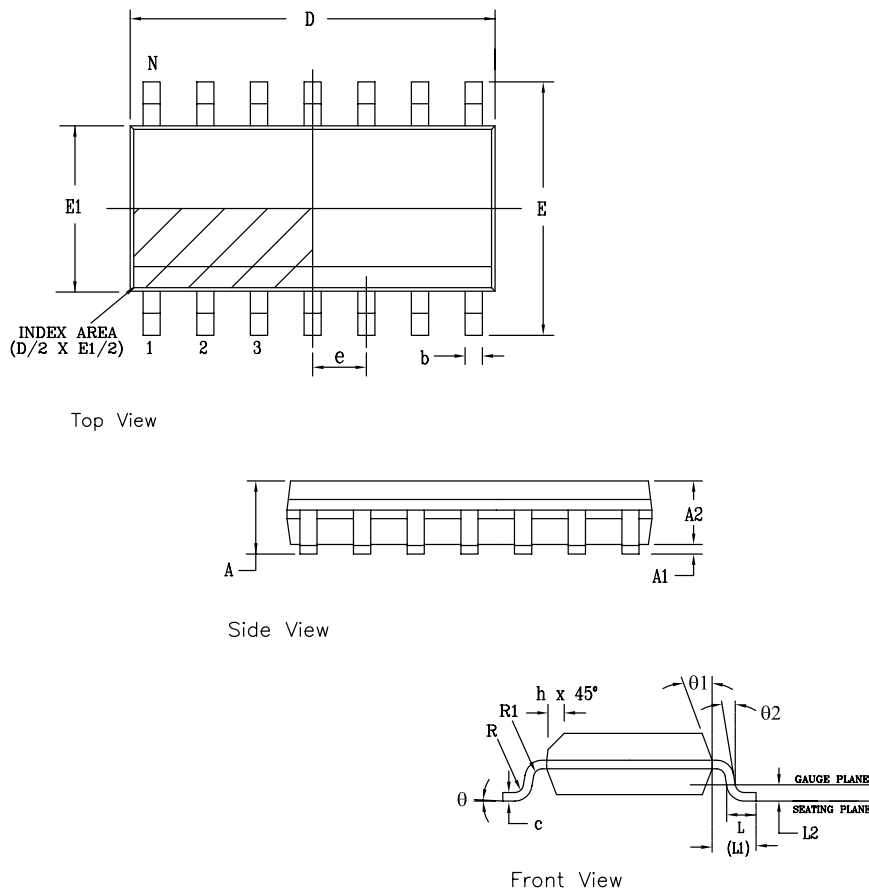

PACKAGE OUTLINE NSOIC .150" BODY JEDEC MS-012						
SYMBOLS	COMMON DIMENSIONS IN MM (Control Unit)			COMMON DIMENSIONS IN INCH (Reference Unit)		
	MIN	NOM	MAX	MIN	NOM	MAX
A	1.35	—	1.75	0.053	—	0.069
A1	0.10	—	0.25	0.004	—	0.010
A2	1.25	—	1.65	0.049	—	0.065
b	0.31	—	0.51	0.012	—	0.020
c	0.17	—	0.25	0.007	—	0.010
E	6.00 BSC			0.236 BSC		
E1	3.90 BSC			0.154 BSC		
e	1.27 BSC			0.050 BSC		
h	0.25	—	0.50	0.010	—	0.020
L	0.40	—	1.27	0.016	—	0.050
L1	1.04 REF			0.041 REF		
L2	0.25 BSC			0.010 BSC		
R	0.07	—	—	0.003	—	—
R1	0.07	—	—	0.003	—	—
theta	0°	—	8°	0°	—	8°
theta1	5°	—	15°	5°	—	15°
theta2	0°	—	—	0°	—	—
D	SEE VARIATIONS					
N	SEE VARIATIONS					

VARIATION D						
SYMBOLS	DIMENSIONS IN MM (Control Unit)			DIMENSIONS IN INCH (Reference Unit)		N
	MIN	NOM	MAX	MIN	MAX	
AA	4.90	BSC	—	0.193	BSC	8
AB	8.65	BSC	—	0.341	BSC	14
AC	9.90	BSC	—	0.390	BSC	16



TSSOP-14 Package

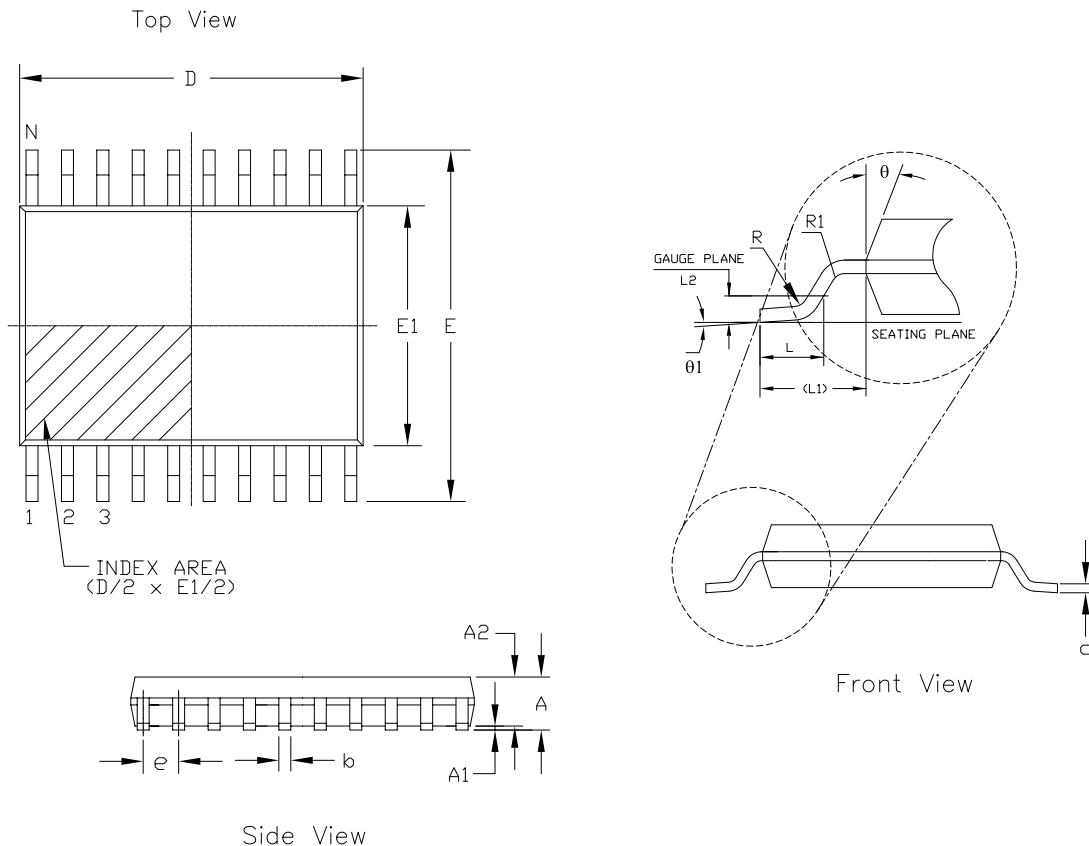

14 Pin TSSOP JEDEC MO-153 Variation AB-1						
SYMBOLS	DIMENSIONS IN MM (Control Unit)			DIMENSIONS IN INCH (Reference Unit)		
	MIN	NOM	MAX	MIN	NOM	MAX
A	—	—	1.20	—	—	0.047
A1	0.05	—	0.15	0.002	—	0.006
A2	0.80	1.00	1.05	0.031	0.039	0.041
b	0.19	—	0.30	0.007	—	0.012
c	0.09	—	0.20	0.004	—	0.008
E	6.40 BSC			0.252 BSC		
E1	4.30	4.40	4.50	0.169	0.173	0.177
e	0.65 BSC			0.026 BSC		
L	0.45	0.60	0.75	0.018	0.024	0.030
L1	1.00 REF			0.039 REF		
L2	0.25 BSC			0.010 BSC		
R	0.09	—	—	0.035	—	—
R1	0.09	—	—	0.035	—	—
$\theta$	12° REF			12° REF		
$\theta1$	0°	—	8°	0°	—	8°
D	4.90	5.00	5.10	0.193	0.197	0.200
N	14			14		

## Ordering Information

Part Number	Package	Green	Operating Temperature Range	Packaging
CLC1007 Ordering Information				
CLC1007IST5X	TSOT-5	Yes	-40°C to +125°C	Tape & Reel
CLC1007IST5MTR	TSOT-5	Yes	-40°C to +125°C	Mini Tape & Reel
CLC1007IST5EVB	Evaluation Board	N/A	N/A	N/A
CLC1007ISO8X	SOIC-8	Yes	-40°C to +125°C	Tape & Reel
CLC1007ISO8MTR	SOIC-8	Yes	-40°C to +125°C	Mini Tape & Reel
CLC1007ISO8EVB	Evaluation Board	N/A	N/A	N/A
CLC2007 Ordering Information				
CLC2007ISO8X	SOIC-8	Yes	-40°C to +125°C	Tape & Reel
CLC2007ISO8MTR	SOIC-8	Yes	-40°C to +125°C	Mini Tape & Reel
CLC2007ISO8EVB	Evaluation Board	N/A	N/A	N/A
CLC2007IMP8X	MSOP-8	Yes	-40°C to +125°C	Tape & Reel
CLC2007IMP8MTR	MSOP-8	Yes	-40°C to +125°C	Mini Tape & Reel
CLC2007IMP8EVB	Evaluation Board	N/A	N/A	N/A
CLC4007 Ordering Information				
CLC4007ITP14X	TSSOP-14	Yes	-40°C to +125°C	Tape & Reel
CLC4007ITP14MTR	TSSOP-14	Yes	-40°C to +125°C	Mini Tape & Reel
CLC4007ITP14EVB	Evaluation Board	N/A	N/A	N/A
CLC4007ISO14X	SOIC-14	Yes	-40°C to +125°C	Tape & Reel
CLC4007ISO14MTR	SOIC-14	Yes	-40°C to +125°C	Mini Tape & Reel
CLC4007ISO14EVB	Evaluation Board	N/A	N/A	N/A

Moisture sensitivity level for all parts is MSL-1.

## Revision History

Revision	Date	Description
1D (ECN 1451-07)	December 2014	Reformat into Exar data sheet template. Updated ordering information table to include MTR and EVB part numbers. Increased "I" temperature range from +85 to +125°C. Removed "A" temp grade parts, since "I" is now equivalent. Updated thermal resistance numbers and package outline drawings.

### For Further Assistance:

Email: [CustomerSupport@exar.com](mailto:CustomerSupport@exar.com) or [HPATechSupport@exar.com](mailto:HPATechSupport@exar.com)

Exar Technical Documentation: <http://www.exar.com/techdoc/>

#### Exar Corporation Headquarters and Sales Offices

48760 Kato Road  
Fremont, CA 94538 - USA

Tel.: +1 (510) 668-7000  
Fax: +1 (510) 668-7001



A New Direction in Mixed-Signal

### NOTICE

EXAR Corporation reserves the right to make changes to the products contained in this publication in order to improve design, performance or reliability. EXAR Corporation assumes no responsibility for the use of any circuits described herein, conveys no license under any patent or other right, and makes no representation that the circuits are free of patent infringement. Charts and schedules contained here in are only for illustration purposes and may vary depending upon a user's specific application. While the information in this publication has been carefully checked; no responsibility, however, is assumed for inaccuracies.

EXAR Corporation does not recommend the use of any of its products in life support applications where the failure or malfunction of the product can reasonably be expected to cause failure of the life support system or to significantly affect its safety or effectiveness. Products are not authorized for use in such applications unless EXAR Corporation receives, in writing, assurances to its satisfaction that: (a) the risk of injury or damage has been minimized; (b) the user assumes all such risks; (c) potential liability of EXAR Corporation is adequately protected under the circumstances.

Reproduction, in part or whole, without the prior written consent of EXAR Corporation is prohibited.



Компания «ЭлектроПласт» предлагает заключение долгосрочных отношений при поставках импортных электронных компонентов на взаимовыгодных условиях!

Наши преимущества:

- Оперативные поставки широкого спектра электронных компонентов отечественного и импортного производства напрямую от производителей и с крупнейших мировых складов;
- Поставка более 17-ти миллионов наименований электронных компонентов;
- Поставка сложных, дефицитных, либо снятых с производства позиций;
- Оперативные сроки поставки под заказ (от 5 рабочих дней);
- Экспресс доставка в любую точку России;
- Техническая поддержка проекта, помощь в подборе аналогов, поставка прототипов;
- Система менеджмента качества сертифицирована по Международному стандарту ISO 9001;
- Лицензия ФСБ на осуществление работ с использованием сведений, составляющих государственную тайну;
- Поставка специализированных компонентов (Xilinx, Altera, Analog Devices, Intersil, Interpoint, Microsemi, Aeroflex, Peregrine, Syfer, Eurofarad, Texas Instrument, Miteq, Cobham, E2V, MA-COM, Hittite, Mini-Circuits, General Dynamics и др.);

Помимо этого, одним из направлений компании «ЭлектроПласт» является направление «Источники питания». Мы предлагаем Вам помощь Конструкторского отдела:

- Подбор оптимального решения, техническое обоснование при выборе компонента;
- Подбор аналогов;
- Консультации по применению компонента;
- Поставка образцов и прототипов;
- Техническая поддержка проекта;
- Защита от снятия компонента с производства.



#### Как с нами связаться

**Телефон:** 8 (812) 309 58 32 (многоканальный)

**Факс:** 8 (812) 320-02-42

**Электронная почта:** [org@eplast1.ru](mailto:org@eplast1.ru)

**Адрес:** 198099, г. Санкт-Петербург, ул. Калинина, дом 2, корпус 4, литера А.