

SAS3416 Tri-Mode IOC

PCIe to 16-port SAS/SATA/PCIe IOC featuring Tri-Mode SerDes Technology

Extending RAID and SAS Technology Leadership, Broadcom Introduces 16-port Tri-Mode SAS/SATA/PCIe IO Controller (IOC)

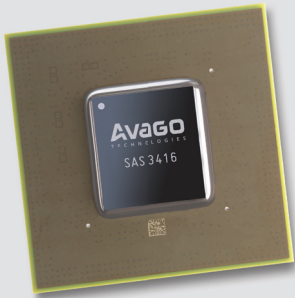

Applications

- Direct Attached SAS/SATA/PCIe controller solutions for server and storage applications
- Utilize PCIe attached SSDs with confidence of industry leading devicemanagement and error recovery

Key Features

- Integrated MegaRAID® support
 - Available upon request
- Multi-core processor
- Tri-Mode (SAS/SATA/PCIe) device ports
 - 16 port SAS+SATA controller
 - Supports 12, 6, and 3Gb/s SAS and 6, 3Gb/s SATA data transfer rates
 - Spread spectrum clocking
 - Supports SSP, SMP, STP and SATA protocols
 - SAS/SATA device support
 - Supports narrow and wide ports
 - T-10 End to End Data Protection (EEDP)

Broadcom Storage

Broadcom products serve four primary target markets: wireless communications, wired infrastructure, enterprise storage, and industrial. Broadcom Storage offers the industry's broadest portfolio of storage solutions, backed by decades of experience and trusted by the world's leading server and storage suppliers. Broadcom provides the building blocks for storage solutions that help customers understand, prioritize, store and protect critical data. The 12 Gb/s SAS portfolio includes Avago MegaRAID® controller cards, Host Bus Adapters (HBAs), Advanced Software Options, Syncro® shared DAS solutions and SAS storage ICs, including RAID-on-Chip (ROCs), I/O controllers and expanders.

Overview

The Avago SAS3416 is the sixth generation of Serial Attached SCSI (SAS) controllers based on the industry-leading Fusion-MPT (Message Passing Technology) architecture. The SAS3416 host interface supports 8 PCI Express (PCIe) lanes and complies with the PCIe 3.1 specification that extends the PCIe data rates up to 8.0 GT/s per lane, and is backwards compatible to the 5.0/2.5 GT/s. It also incorporates End-to-End CRC (ECRC) with Advanced Error Reporting (AER) lane and polarity reversal, power management, hot plug support, and MSI/ MSI-X and legacy interrupt generation.

Key Features (cont.)

- T-10 Optical Support
- SAS 2.1 power management
- Supports up to 2,000 SAS/SATA devices
- Supports DataBolt bandwidth aggregation technology
- Up to 4 PCIe links. Each link supporting x4, x2 link widths, supporting 8.0 GT/s (PCIe Gen3) per lane
- Separate Refclk Independent SSC (SRIS)
- PCIe application layer supports NVMe
- Up to 16 PCIe devices behind a switch supported
- PCIe 3.1 Host Interface
 - Supports x8, x4, x2 PCIe lanes at a transfer rate up to 8.0 GT/s per lane, full duplex
 - Lane and polarity reversal
 - Supports End-to-End CRC (ECRC) and Advanced Error Reporting (AER)
 - PCIe hot plug support
 - Variable PCIe bandwidth negotiation
- Advanced power management support
 - Slumber and partial power mode support for SAS/SATA devices
 - Programmable SAS link power down
 - Variable PCIe bandwidth negotiation

SFF-8680 “Tri-Mode Universal Bay” Topology

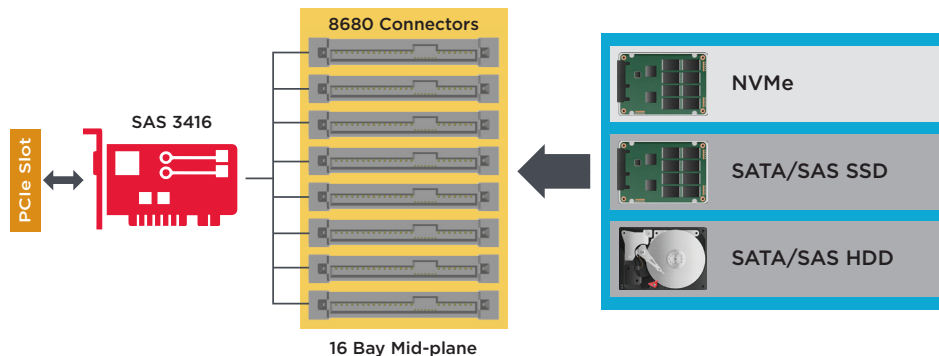

Avago Tri-Mode SerDes Technology enables seamless operation of PCIe, SAS, or SATA storage devices in a single drive bay. The introduction of PCIe devices executing NVMe command sets to the existing SAS/SATA infrastructure makes industry standard hot-pluggable drive bays even more versatile. The eight-port Tri-Mode device interface provides SAS data transfer rates of 12, 6, and 3Gb/s per lane, or SATA at 6 and 3Gb/s data transfer rates per lane, or PCIe data transfer rates of 8, 5, and 2.5 Gb/s. The device automatically negotiates between the speeds and protocols. T-10 Data Protection Model (T-10 End to End Data Protection (EEDP) for early detection of and recovery from data corruption, and Spread Spectrum Clocking (SSC) for EMI reduction are supported. Additional features include SAS 2.1 power management and DataBolt Technology allowing users to take advantage of 12Gb/s speeds while utilizing existing 6Gb/s drives and backplanes.

The SAS3416 supports up to 4 direct attached PCIe devices and complies with PCIe 3.1 specifications, PCIe Dynamic Power allocation (DPA), ECRC, and AER with compatible devices. The device also supports NVMe over over PCIe to attached PCIe devices.

The SAS3416 is ideal for the host or drive side connect for external storage controllers requiring a SAS/SATA interface. It can support up to 2,000 SAS or SATA devices and 8,000 outstanding IOs without external RAM and can achieve over 1 million IOs per second.

Broadcom provides a complete suite of industry standard operating system drivers. Avago also supports Virtual Operating Systems with device emulation and para-virtualization.

Key Features (cont.)

- External memory interface support – SPI based Flash ROM
- Communication interfaces
 - I²C interfaces for enclosure management services
 - UART and Ethernet interface for debug
- SFF-8485 compliant, SGPIO
- JTAG support
- Package (estimated) 25mm

Fusion-MPT Architecture Overview

Fusion-MPT architecture marks the next generation of I/O architecture designed to deliver the highest performance available today while reducing time to market, integration, and certification time. Fusion-MPT devices are high performance, cost-effective protocol controllers that represent the newest system-level integration technology in intelligent I/O processors from Broadcom.

Figure 1: Direct Attach with PCIe, SAS and SATA RAID volumes behind a single controller in servers with multiple drive bays

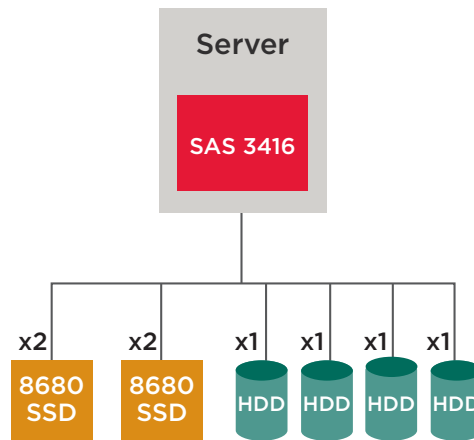

Mix PCIe / SAS / SATA HDD or SSD in any combination utilizing 16 phys

Figure 2: Direct Attach with PCIe SSDs for application acceleration in servers

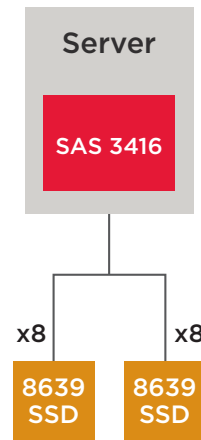

Mix PCIe / SAS / SATA HDD or SSD in any combination utilizing 16 phys

Figure 3: SAS 3408 Block Diagram

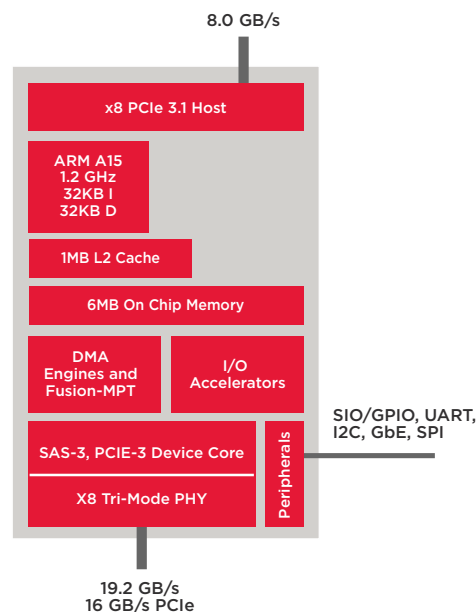



Компания «ЭлектроПласт» предлагает заключение долгосрочных отношений при поставках импортных электронных компонентов на взаимовыгодных условиях!

Наши преимущества:

- Оперативные поставки широкого спектра электронных компонентов отечественного и импортного производства напрямую от производителей и с крупнейших мировых складов;
- Поставка более 17-ти миллионов наименований электронных компонентов;
- Поставка сложных, дефицитных, либо снятых с производства позиций;
- Оперативные сроки поставки под заказ (от 5 рабочих дней);
- Экспресс доставка в любую точку России;
- Техническая поддержка проекта, помощь в подборе аналогов, поставка прототипов;
- Система менеджмента качества сертифицирована по Международному стандарту ISO 9001;
- Лицензия ФСБ на осуществление работ с использованием сведений, составляющих государственную тайну;
- Поставка специализированных компонентов (Xilinx, Altera, Analog Devices, Intersil, Interpoint, Microsemi, Aeroflex, Peregrine, Syfer, Eurofarad, Texas Instrument, Miteq, Cobham, E2V, MA-COM, Hittite, Mini-Circuits, General Dynamics и др.);

Помимо этого, одним из направлений компании «ЭлектроПласт» является направление «Источники питания». Мы предлагаем Вам помощь Конструкторского отдела:

- Подбор оптимального решения, техническое обоснование при выборе компонента;
- Подбор аналогов;
- Консультации по применению компонента;
- Поставка образцов и прототипов;
- Техническая поддержка проекта;
- Защита от снятия компонента с производства.



Как с нами связаться

Телефон: 8 (812) 309 58 32 (многоканальный)

Факс: 8 (812) 320-02-42

Электронная почта: org@eplast1.ru

Адрес: 198099, г. Санкт-Петербург, ул. Калинина, дом 2, корпус 4, литера А.