

FEATURES

- Built-in Current Transformers for direct measurement of 0 to 2/20/50/100 Amps
- Functionally complete:
 - On-board current transformers
 - Scaling/interface circuitry
 - Precision A/D converters
 - Bright red LED displays
- 8 different models
- Subminiature, 1.38" x 0.88" package
- Easy-to-read, 0.37"/9.4mm digits
- AC powered models 85-264Vac @ 50/60Hz
- "Self-powered" 85-264Vac, 2A and 20A models feature built-in load connections
- +5-40V dc powered models
- 2000V isolation; UL/CSA recognized

DATEL's new ACA-20PC Series are the first digital ac ammeters to incorporate on-board current transformers (CT's), and they are amazingly easy to use. Simply pass the current-carrying load wire through the ACA-20PC's on-board CT, apply power to the meter's two supply terminals, and you're instantly measuring ac currents over one of four ranges (0-2A with 1mA resolution, 0-20A with 10mA resolution, or 0-50A and 0-100A with 100mA resolution). Absolutely no external components, such as expensive low-value shunts or 5A "donut" CT's, are required.

Meters are ac powered (120/220Vac @ 50/60Hz) or dc powered (+5-40V) and impose minimal loads (50mA max. and 120mA max., respectively) on their supplies. All models employ auto-zeroing circuits, precision bandgap references, and super stable thin-film resistors for unsurpassed accuracy ($\pm 0.15\%$ FS) and stability.

The functionally complete ACA-20PC ammeters provide all the scaling/interface circuitry to mate the CT's output to a precision (3½ digit) A/D converter. The A/D's output goes directly to drivers for the meters' large (0.37"/9.4mm digit height), easy-to-read, LED displays. AC-powered units have on-board AC/DC converters, and wide-range dc-powered units have on-board linear regulators. AC-powered models can be powered by the same ac supply whose current they are monitoring. The 2A and 20A, 85-264Vac, 50/60Hz ("AC1") models feature additional on-board terminal blocks to supply power to the external load. All models provide 2000Vdc isolation between the measured ac current and their power supply, and all are UL/CSA recognized.

Each meter is housed in a subminiature, 1.38" x 0.88", epoxy-encapsulated package. Total behind-the-panel installation depth is approximately 2 inches.

SIMPLIFIED SCHEMATIC DIAGRAM

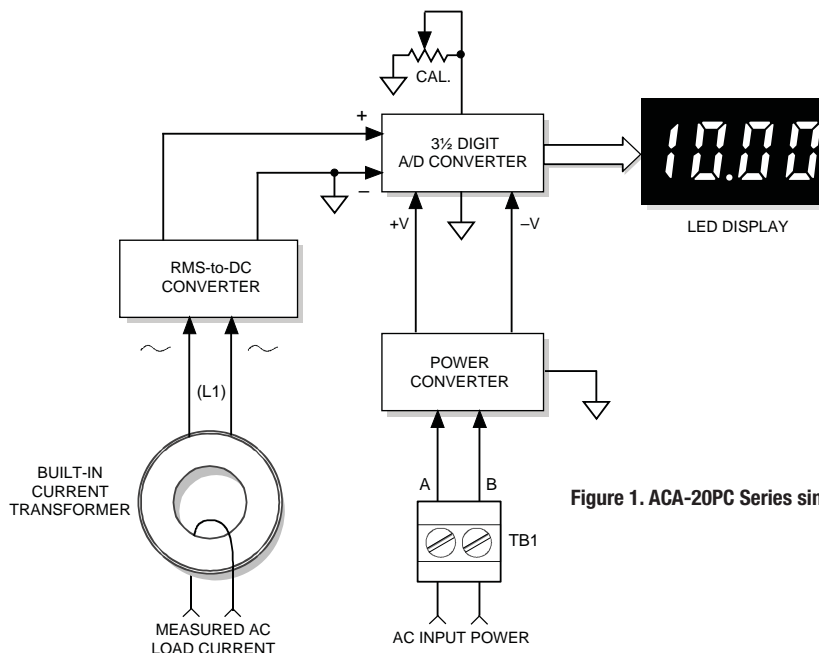

Figure 1. ACA-20PC Series simplified schematic



Performance/Functional Specifications

Typical at TA = +25°C, unless otherwise noted. ①

Full-Scale Current (45-450Hz) ②	Min.	Typ.	Max.	Units
ACA-20PC-1-XXX-XX	–	–	1.999	Amps
ACA-20PC-2-XXX-XX ③	–	–	19.99	Amps
ACA-20PC-3-XXX-XX	–	–	50.0	Amps
ACA-20PC-4-XXX-XX	–	–	100.0	Amps
DMS-30798-C	–	–	30.0	Amps
Overcurrent Rating ②	1.5 x rated full-scale current			
Performance				
Sampling Rate	2.5 reading per second			
Accuracy ②	±0.15%FS ±6 Counts			
Measurement Type	Sine wave input, full-wave averaging, rms calibrated			
Temperature Drift (0 = +60°C)	–	±0.2	±0.4	Cnts/°C
Zero Reading (Vin = 0 Volts)	“–001”	“000”	“001”	Counts
Dielectric Withstanding Voltage	2000	–	–	Vdc
Power Supply Voltage ⑤				
ACA-20PC-X-AC1-RL (47-99Hz)	85	120	264	Vac
ACA-20PC-X-DC1-RL	+4.75	–	+40	Vdc
Power Supply Current ④				
ACA-20PC-X-AC1-RL (47-99Hz)	–	30	50	mA
ACA-20PC-X-DC1-RL	–	+8	+12	mAdc
Power Supply Terminal Block				
ACA-20PC-1-AC1-RL and ACA-20PC-2-AC1-RL (2A and 20A ac-powered models with 4-position terminal blocks):				
Wire Size and Type	12-20AWG (solid), 14-20AWG (stranded)			
Insulation Strip Length	0.25 inches			
Screw Tightening Torque	4.4 pounds/inches (0.5Nm)			
Maximum Rated Current	20A with 12AWG solid wire; 15A with 14AWG solid or stranded wire			
Maximum Rated Voltage	630V (VDE 0110-V Group 2) 250V (VDE 0110-V Group 3)			
ACA-20PC-X-XXX-XX (All other ac or dc-powered models with 2-position terminal blocks):				
Wire Size and Type	16-24AWG (solid or stranded)			
Insulation Strip Length	0.25 inches			
Screw Tightening Torque	3.6 pounds/inches (0.5Nm)			
Display				
Display Type and Size	3½ digit, 0.37"/9.4mm high LED			
Overrange Indication	“1 _ _”			
Decimal Point	Fixed, model dependent			
Physical/Environmental				
Operating Temperature	0	–	+60	°C
Storage Temperature	–40	–	+75	°C
Humidity (non-condensing)	0	–	95	%

Physical/Environmental	
Case Material	Polycarbonate
Dimensions	1.38"W x 0.88"H. Depth is model dependent (see mechanical specification)
Weight:	
ACA-20PC-1-XXX-XX	1.1 ounces (31 grams)
ACA-20PC-2-XXX-XX	1.1 ounces (31 grams)
ACA-20PC-3-XXX-XX	1.3 ounces (37 grams)
ACA-20PC-4-XXX-XX	1.5 ounces (43 grams)
DMS-30798-C	1.0 ounces (28 grams)

- ① The ACA-20PC-1-AC1-RL and ACA-20PC-2-AC1-RL have 4-position on-board terminal blocks. All other models have 2-position terminal blocks.
- ② Specified full-scale currents are those passing through the built-in CT's primary(load) circuit, over the frequency of 45-450Hz. The Overcurrent Rating is a continuous rating that applies to the measured ac load current. It does not apply to any circuitry external to the meter. Accuracy is guaranteed to the rated current.
- ③ For the ACA-20PC-2-AC1-RL, if the load is connected to the meter's on-board 4-position terminal block, the 20A full scale range requires 12AWG solid copper wire on all connections. If 14AWG solid copper wire is used, the current should be limited to 15A. See Figure 3.
- ④ All specified maximum power supply currents are steady-state values. AC-powered models can draw higher surges at initial turn-on.
- ⑤ Maximum reverse polarity protection on "DC1" models is –40Vdc.

Ordering Information

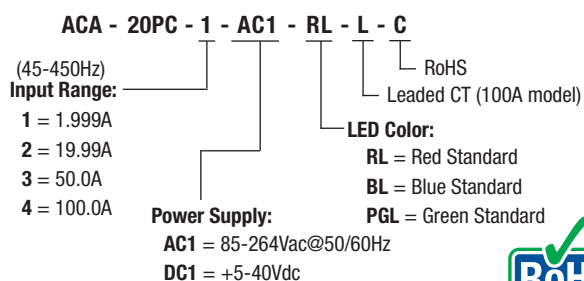

DMS-30798-C: 30Amp model with a wire lead CT and “-AC1” power supply specifications. See Mechanical section for dimensions.

Accessories: DMS-20-CP Panel cutout punch

A DMS-BZL4-C bezel assembly with sealing gasket is supplied with each ammeter.

TECHNICAL NOTES

IMPORTANT! To ensure safe and reliable operation, ACA-20PC ammeters must be installed and serviced by qualified technical personnel. Contact DATEL if there is any doubt regarding ammeter installation and/or operation.

- 1. Measurement Type:** ACA-20PC ac ammeters employ a full-wave-rectified, average responding, rms-calibrated circuit to measure the stepped-down output of their on-board, L1 current transformer (CT). Stated accuracy specifications are measured using a sine-wave current at or close to the specified full scale input level, at nominal line frequency.
- 2. Calibration:** Periodic recalibration of ACA-20PC ammeters is not required under normal, indoor operating environments. If user calibration is necessary, it should be performed by qualified technical personnel. Calibration is performed with potentially lethal voltages applied to the ACA-20PC and its associated wiring, with the specified full-scale current flowing through the ammeter's built-in current transformer.

A plastic, fully insulated adjusting tool must be used to access the recessed calibration potentiometer located on the back of the meter (see Mechanical Specifications). Contact DATEL if additional information is required regarding calibration, setup, or any other technical issue pertaining to the ACA-20PC.

- 3. Wire Gauges and Fusing:** Wires specified in the Functional Specifications section must be used for making connections to ACA-20PC Series ammeters. All power-supply and load wiring must be rated for the supply voltages and currents they will conduct and must comply with any code or application-mandated requirements pertaining to the user's specific installation.

ACA-20PC Series ammeters are not internally fused. Special attention must be paid to ACA-20PC-1-AC1 (0-2A range) and ACA-20PC-2-AC1 (0-20A range) ac-powered models when their built-in auxiliary terminal block connections on TB1 are used to supply power to an external load. The input supply wires connected to both the ammeter and the load must be fused according to the current rating of the wire gauge being used, in accordance with applicable regulatory codes, but not to exceed TB1's maximum 20A rating. If TB1 is not used to supply power to external loads, a 0.25A/250V time delay/time lag fuse must be used.

ACA-20PC-3-AC1 (0-50A range, ac-powered) and ACA-20PC-4-AC1 (0-100A, ac-powered) models' TB1 is to be used only for powering the ammeters' internal circuitry; it must not be used to supply power to external loads. The supply wires feeding these models must be fused with a 0.25A time delay/time lag fuse, in accordance with applicable regulatory codes.

Wire insulation must be stripped to within $\pm 10\%$ of the stated dimensions, and wires should be inserted into TB1 such that their insulation is not pinched by the screw terminal.

- 4. AC Supply Polarity and Grounding:** The two ac supply inputs, TB1-A and TB1-B, on ac-powered ammeters are not in themselves polarity sensitive, that is, they have no internal "AC LO" or "AC HI"

designations. Also, ac-powered ACA-20PC ammeters do not include or require a connection to earth/chassis ground. However, in many applications, external ac loads which are connected directly to the ACA-20PC's built-in auxiliary terminal blocks must be wired with proper polarity and connected to earth/chassis ground.

- 5. Connector Torque Ratings:** It is important to tighten TB1's screw terminals to their rated torque specifications of 4.4 pound-inches (0.5Nm) for four-terminal ammeters (ACA-20PC-1-AC1-RL and ACA-20PC-2-AC1-RL), and 3.6 pound-inches (0.4Nm) for two-terminal ammeters. Proper tightening will minimize connector losses and ensure safe, reliable operation.
- 6. 100 Amp Model (ACA-20PC-4-XXX):** This model's built-in current transformer requires a larger panel cutout width dimension. See Mechanical Specifications for more information.
- 7. DC-Powered Models:** DC-powered models draw minimal supply currents and in most applications can be fused according to the supply wire's maximum amperage rating. However, be sure to check and comply with all applicable codes and regulations to ensure proper installation and operation.
- 8. Isolation:** The on-board CT (L1) provides a minimum 2000Vdc isolation between the current-carrying conductor passing through its primary circuit and the ammeter supply voltage connected to TB1. Of course, this isolation rating only applies to applications in which the load wiring (i.e., the wire passing through the CT's center hole) does not connect directly or indirectly to TB1-A or TB1-B.

PANEL INSTALLATION

All connections to ACA-20PC Series ammeters must be made after the ammeter is securely attached to the panel and with all load and supply voltages de-energized (off).

Care should be exercised when passing the load-carrying conductor through the meter's built-in CT—particularly when larger-gauge conductors are used. The position of the installed wire should be such that minimal forces are applied to the built-in CT, TB1, or to the ammeter itself. In high-vibration environments, adequate strain reliefs be used for all load and supply wiring.

To ensure a secure panel-mount installation, DATEL recommends using the DMS-BZL4 bezel assembly (with sealing gasket) supplied with each ammeter. Also, please note that the ACA-20PC-4-XXX 100A oversized CT requires a larger panel-cutout width of 1.350" (34.3mm). See Mechanical Specifications for detailed cutout and ammeter dimensions.

Following the four-step sequence shown in Figure 2 below—being careful not to apply excessive force or twisting motions—insert the ammeter into the panel opening. When using the DMS-BZL4 bezel assembly, install its sealing gasket so it is positioned between the ammeter's front flange and panel front surface (see Mechanical Specifications). Be sure to use and securely tighten all four screws supplied with the bezel assembly.

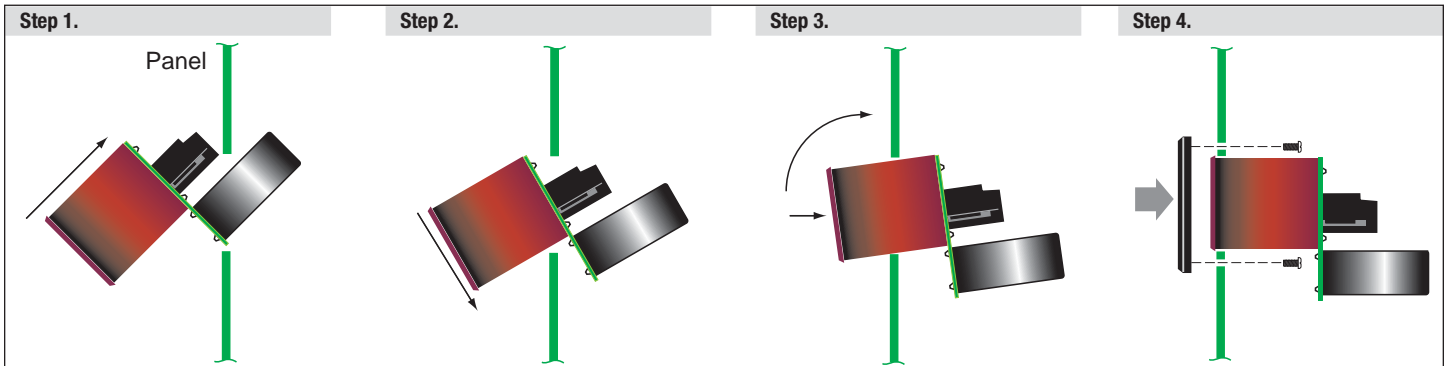

Figure 2. Panel Installation

TYPICAL WIRING DIAGRAM

First pass and carefully dress one external load wire through the on-board CT (L1). Then connect the ac supply and load wires to TB1 as shown. If required, verify that correct line-power polarities are applied to the external load (see Technical Note 4). Ensure all wires are stripped and terminals torqued correctly. For proper operation, pass only one load wire through the on-board CT's center hole.

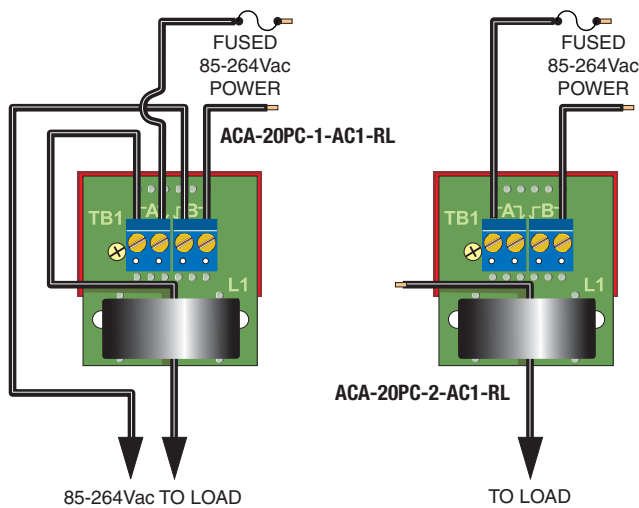

Figure 3. 2A and 20A, 85-264V AC-Powered Models With Auxilliary Load Connections

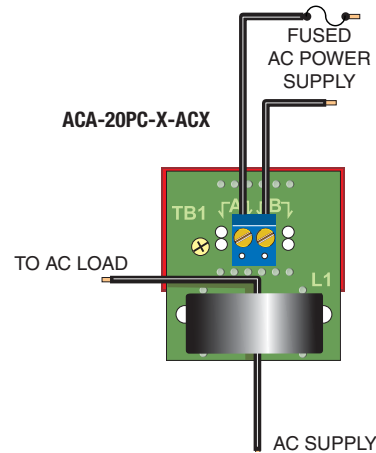

Figure 4. All Other AC-Powered Models

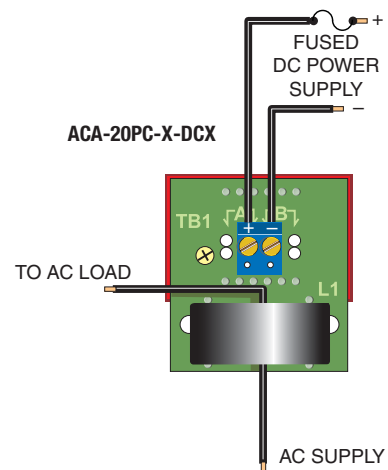
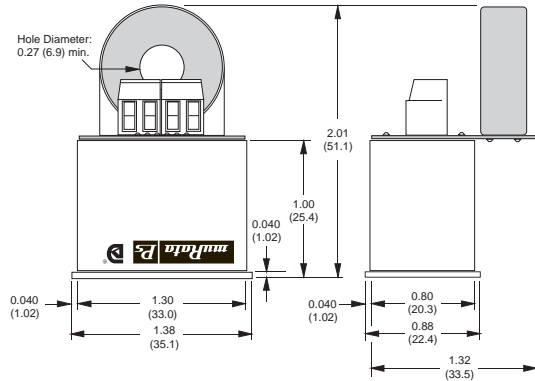

Figure 5. All DC-Powered Models

MECHANICAL SPECIFICATIONS

ACA-20PC-1 & 2-AC1-RL

2A and 20A, 85-264V ac-powered models



FRONT VIEW



BACK VIEW

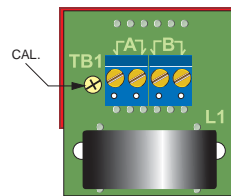

ACA-20PC-1 & 2

2A and 20A, all other models

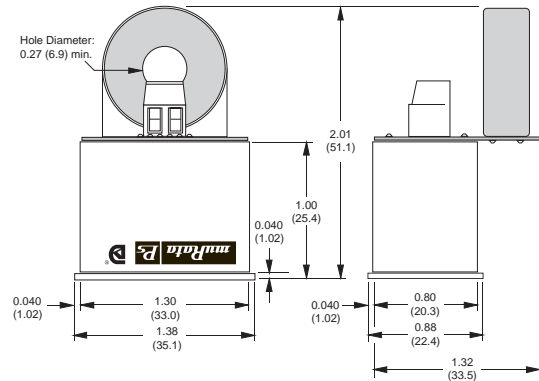

FRONT VIEW



BACK VIEW

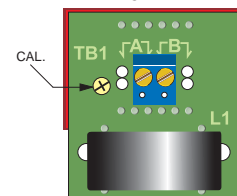

ACA-20PC-3 Series

50A models

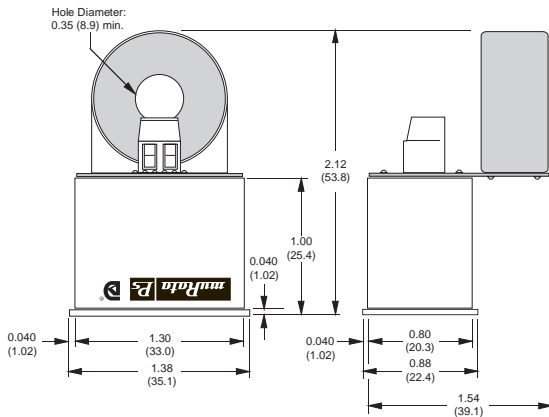

FRONT VIEW



BACK VIEW

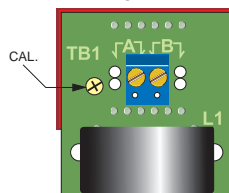

ACA-20PC-4 Series

100A models with pc-board mounted CTs

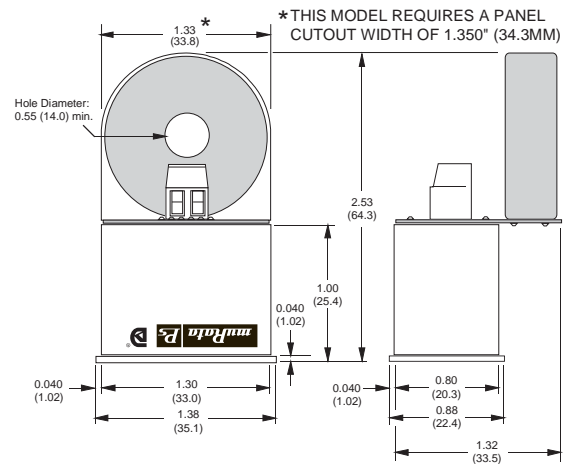

FRONT VIEW



BACK VIEW

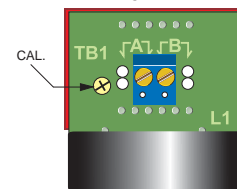

MECHANICAL SPECIFICATIONS, CONTINUED

ACA-20PC-4-XXX-L (100A model)
DMS-30798-C (30A model)

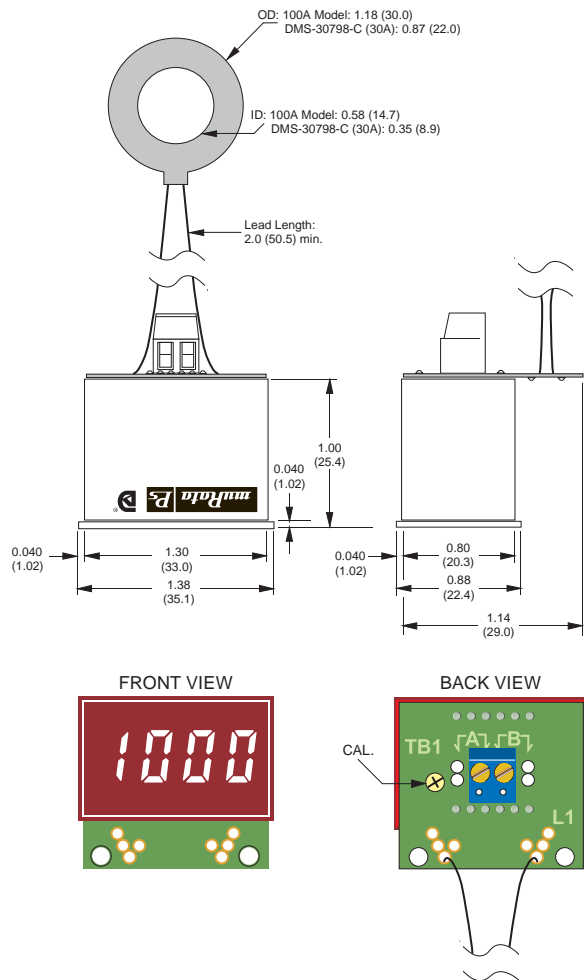

BEZEL INSTALLATION AND RECOMMENDED DRILL AND PANEL CUTOUT

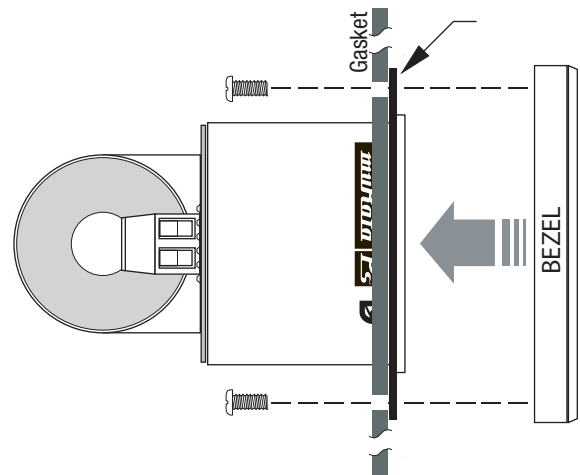
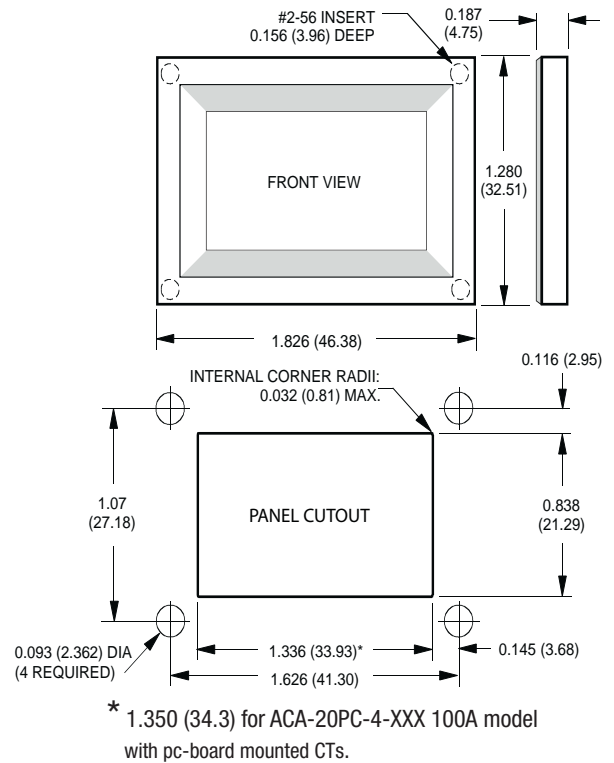



Компания «ЭлектроПласт» предлагает заключение долгосрочных отношений при поставках импортных электронных компонентов на взаимовыгодных условиях!

Наши преимущества:

- Оперативные поставки широкого спектра электронных компонентов отечественного и импортного производства напрямую от производителей и с крупнейших мировых складов;
- Поставка более 17-ти миллионов наименований электронных компонентов;
- Поставка сложных, дефицитных, либо снятых с производства позиций;
- Оперативные сроки поставки под заказ (от 5 рабочих дней);
- Экспресс доставка в любую точку России;
- Техническая поддержка проекта, помощь в подборе аналогов, поставка прототипов;
- Система менеджмента качества сертифицирована по Международному стандарту ISO 9001;
- Лицензия ФСБ на осуществление работ с использованием сведений, составляющих государственную тайну;
- Поставка специализированных компонентов (Xilinx, Altera, Analog Devices, Intersil, Interpoint, Microsemi, Aeroflex, Peregrine, Syfer, Eurofarad, Texas Instrument, Miteq, Cobham, E2V, MA-COM, Hittite, Mini-Circuits, General Dynamics и др.);

Помимо этого, одним из направлений компании «ЭлектроПласт» является направление «Источники питания». Мы предлагаем Вам помощь Конструкторского отдела:

- Подбор оптимального решения, техническое обоснование при выборе компонента;
- Подбор аналогов;
- Консультации по применению компонента;
- Поставка образцов и прототипов;
- Техническая поддержка проекта;
- Защита от снятия компонента с производства.



Как с нами связаться

Телефон: 8 (812) 309 58 32 (многоканальный)

Факс: 8 (812) 320-02-42

Электронная почта: org@eplast1.ru

Адрес: 198099, г. Санкт-Петербург, ул. Калинина, дом 2, корпус 4, литера А.