

## MP-7217-DA Datasheet

### MEM's Catalytic Combustible Gas Sensor (Miniature)

This datasheet describes the use of the MP-7217-DA Pellistor. This is commonly used, but not exclusively, in mining applications. It is a low power, intrinsically safe, extremely robust and poison-resistant device in a certified flameproof enclosure.

The MP-7217-DA has been designed to provide the basic sensor performance that will enable a suitable instrument to meet the various (Group 1) mining performance standards.

The MP-7217-DA sensors, whilst being optimised for its methane response (up to 5% volume in air), will also detect some other flammable gases and vapours. For further information, contact SGX Sensortech.

### FEATURES

- Low power – designed for battery operation
- Small size (Ø14mm)
- High resistance to mechanical shocks
- Assessed as intrinsically safe
- Low orientation effect
- ATEX Certified
- IECEx certified



### OPERATING PRINCIPLE

The silicon pellistor structure consists of a pair of accurately micro machined diaphragms with two embedded planar heater meanders coated with a layer incorporating a noble metal catalyst for the detector device and with inert layer for the compensator device.

The meander acts both as an electrical heater and as a resistance thermometer. The device is mounted on a PCB with wire bonding and is surrounded by a plastic can with the end open to the atmosphere. If a flammable gas is present when the device is heated to about 400 – 500 °C, the gas will oxidise and the resultant release of energy will heat the device still further. This increase in temperature is detected as an increase in resistance of the meander. The temperature of the meander is also affected by ambient temperature and by variations in thermal conductivity of the air caused by the possible presence of inert gases such as carbon dioxide. To compensate for temperature changes not caused by the oxidation of the flammable gas a second, inert device is used.

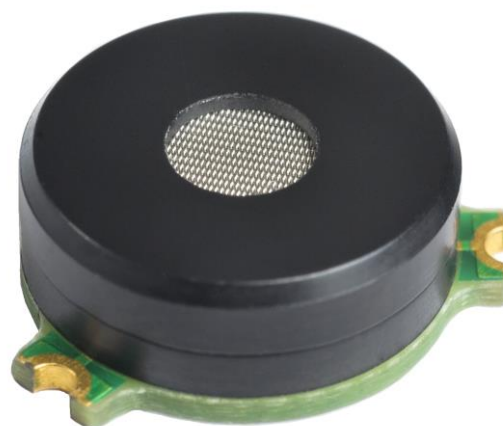

This compensator is made in the same way as a detector device except that instead of incorporating a catalyst in the coating layer, the device is treated so that oxidation cannot take place.

The two devices are then used in a circuit that detects the difference in their resistances. Since the two devices are generally a different colour, they have different emissivity and hence different slope resistances. Therefore, to obtain the best temperature performance, it is necessary on occasion to connect a fixed resistor in parallel with the compensator to correct for its higher slope resistance.

### TECHNICAL SPECIFICATION

#### Mechanical

Dimensions	see outline, page 4
Body material	PEI
Weight	1g

#### Environmental

Ambient temperature range for operation / storage: certified:	-40 to +60 °C -40 to +60 °C
Operational pressure range	70 to 130 kPa
Humidity range for operation and storage	0 to 95% (non-condensing)
Gases Detected	Most flammable gases and vapours

#### Electrical

DC supply to detectors	+2.9 to +3.1V;
Typical power	39 to 47mA (<96mA at power on)
Mode of Operation	Continuous

Whilst SGX has taken care to ensure the accuracy of the information contained herein it accepts no responsibility for the consequences of any use thereof and also reserves the right to change the specification of goods without notice. SGX accepts no liability beyond the set out in its standard conditions of sale in respect of infringement of third party patents arising from the use of SGX products in accordance with information contained herein. In case of modification of the product, SGX disclaims all liability.

## PERFORMANCE

<b>Minimum sensitivity</b> <i>(measured with 1% methane at 3.0 ± 0.1V)</i>	12 mV/% methane
<b>Zero offset range in clean air</b>	± 20 mV
<b>Response Time (T<sub>90</sub>)</b> <i>(See Note 2)</i>	< 12 sec
<b>Maximum gas concentration</b> <i>(see note 3)</i>	5% methane in air
<b>Long Term Zero drift</b> <i>(see note 4)</i>	< 1.0 mV / month
<b>Long Term Sensitivity drift</b> <i>(see note 5)</i>	< 0.6 mV / month

## MAXIMUM RATINGS (Absolute values)

Input voltages between pins:	
<b>Pins 2 and 3</b>	3.2 V
<b>Pins 1 and 2</b>	1.6 V
<b>Pins 1 and 3</b>	1.6 V

## OPERATION

It is recommended that the detector and compensator be run in a Wheatstone bridge circuit.

A suitable circuit is shown below. In use, the bridge supply voltage should be stable to within + 0.05 V, or the output in clean air may change in sympathy. Although it is generally recommended that pellistors should be run with a constant voltage supply to the bridge, it is possible to use a constant current supply provided that the voltage across the bridge in clean air remains within the recommended limits.

**Recommended circuit diagram**

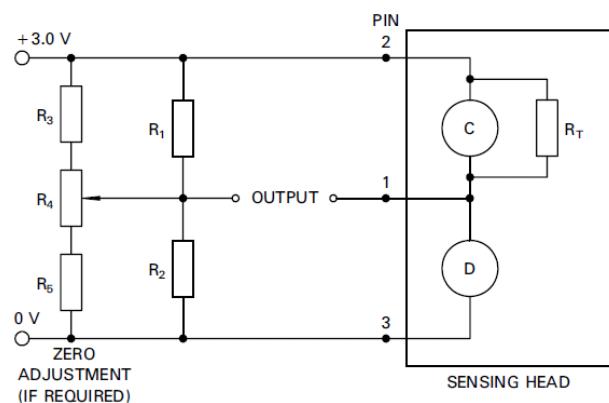

$$R_1 = R_2 = 500\Omega \text{ to } 10 \text{ k}\Omega$$

$$R_3 = R_5 \approx 10R_1$$

$$R_4 \approx 20R_1$$

## NOTES

1. The polarity of the supply voltage may be reversed without harm. The only effect is to reverse the polarity of the output signal.
2. Maximum (slowest) response time measured at 3.0 ± 0.1 V using 1% methane in an SGX test manifold. Faster response times will be achieved in instruments/detectors with optimised gas delivery.
3. Exceeding these limits may degrade the stability of sensitivity or zero offset. The calibration of the sensor should be checked if it has been exposed, whilst operating, to gas concentrations greater than the Lower Explosive Limit.
4. Over 90 day period.
5. Measured at 3.0 ± 0.1V using 1% methane, over 90 days period.

## IMPORTANT PRECAUTIONS

Read the following instructions carefully before using the MP-7217-DA to avoid erroneous readings and to prevent the device from permanent damage.

- Heater voltages above the specified maximum rating can damage the MEMS Pellistor.
- Some compounds are known to affect the catalytic reaction of coating material used in pellistors.
  - Exposure to silicones (by far the most common & virulent poison), high levels of hydrogen sulfide (and other sulfur containing compounds), phosphates and phosphorous containing substances or lead containing compounds (e.g. tetraethyl lead) will irreversibly poison the sensor. High concentrations of flammable gas may also permanently affect the sensor response.
  - Lower concentrations of hydrogen sulfide and other compounds can cause a temporary loss in response. This is known as inhibition. Halogenated hydrocarbons such as Freons™, trichloroethylene, and methyl chloride are also possible inhibitors. Sensors generally recover most of their original response once they are returned to fresh air.
  - Specific protection may be needed in applications where poisons or inhibitors are continuously present.
- SGX recommends using ESD protection equipment when handling the sensor.
- Care should be taken when soldering the device as excessive heat could cause irreparable damage to sensor elements.
- Please contact SGX Sensortech for any additional information.

## CERTIFICATION

	ATEX	IECEX
<b>Certificate / File:</b>	OBAC 18 ATEX 0024U	IECEX OBAC 18.0001U
<b>Standards:</b>	EN 60079-0:2012 EN 60079-1:2014 EN 50303:2000	IEC 60079-0 ed6.0 (2011) IEC 60079-1 ed7.0 (2014-06)
<b>Product Marking:</b>	 II 1G Ex da IIC Ga I M1 Ex da I Ma	Ex da IIC Ga Ex da I Ma
<b>Certified Manufacturing Locations:</b>	SGX Europe Sp. z o.o., Ligocka 103, 40-568 Katowice, Poland SGX Sensortech (SA), Courtils 1, 2035 Corcelles-Cormondreche, Switzerland	
<b>Certificate Address:</b>	SGX Europe Sp. z o.o., Ligocka 103, 40-568 Katowice, Poland	

### INSTRUCTIONS SPECIFIC TO HAZARDOUS AREA INSTALLATIONS

(Ref : EU ATEX Directive 2014/34/EU)

1. The **MP-7217-DA** Gas Sensor is component approved only and may not be used as a stand-alone item in a hazardous area without further protection.
2. There are no user-serviceable parts in the component.
3. The end-user/installer should be aware that the certification of the MP-7217-DA Gas Sensor relies on the following materials used in its construction, which are suitable for most common applications:

Enclosure PEI-ULTEM 1000 or PPS-GF40

Stainless Steel Mesh Flame Arrestor

In accordance with the Note in EN60079-0: Clause 6.1, the end-user/installer shall inform the manufacturer of any adverse conditions that the **MP-7217-DA** Gas Sensor may encounter. This is to ensure that the **MP-7217-DA** Gas Sensor is not subject to conditions that may cause degradation of these materials.

4. There are no user-serviceable parts in the component.
5. The **MP-7217-DA** Gas Sensor has not been assessed as a safety device (EHSR 1.5).
6. The **MP-7217-DA** has been assessed to the following entity parameters:  

Ui: 10 V, Pi: 1.3 W, Li: 0 H, Ci: 0 F
7. The sensors have been determined suitable for Group I and Group II environments, provided no Group I dust enters the sensor, for a service temperature range of -40°C to +60°C.
8. The sensors have been assessed for internal mounting only and shall not form part of the external enclosure of the end-product.
9. The sensors provide adequate separation between internal conductors and accessible external surfaces for voltages ≤ 10 V. The end-product designer must ensure that adequate separation is provided from conductors.
10. A minimum ingress protection rating of IP20 was considered for the purposes of the assessment. The end-product enclosure is required to give the required ingress protection (IP) rating for the intended environment.
11. The maximum surface temperature rise of the sensor has been determined to be 28 K.
12. The end-product designer must limit the steady-state current into the sensor to less than 641 mA with considerations made to any other applicable clauses of the standard used for the end-product.

## PACKAGE DIMENSIONS

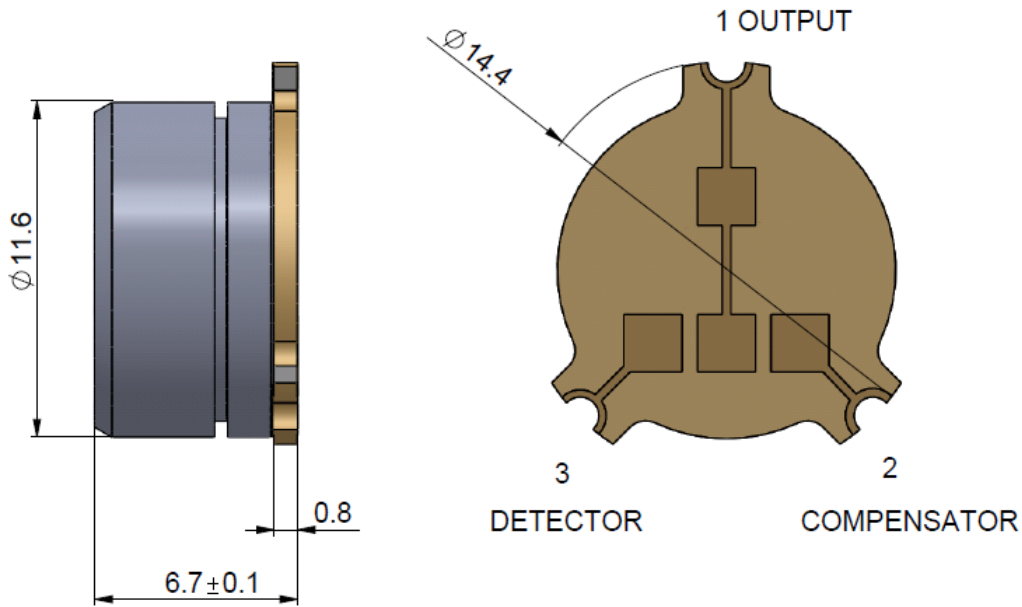



Компания «ЭлектроПласт» предлагает заключение долгосрочных отношений при поставках импортных электронных компонентов на взаимовыгодных условиях!

Наши преимущества:

- Оперативные поставки широкого спектра электронных компонентов отечественного и импортного производства напрямую от производителей и с крупнейших мировых складов;
- Поставка более 17-ти миллионов наименований электронных компонентов;
- Поставка сложных, дефицитных, либо снятых с производства позиций;
- Оперативные сроки поставки под заказ (от 5 рабочих дней);
- Экспресс доставка в любую точку России;
- Техническая поддержка проекта, помощь в подборе аналогов, поставка прототипов;
- Система менеджмента качества сертифицирована по Международному стандарту ISO 9001;
- Лицензия ФСБ на осуществление работ с использованием сведений, составляющих государственную тайну;
- Поставка специализированных компонентов (Xilinx, Altera, Analog Devices, Intersil, Interpoint, Microsemi, Aeroflex, Peregrine, Syfer, Eurofarad, Texas Instrument, Miteq, Cobham, E2V, MA-COM, Hittite, Mini-Circuits, General Dynamics и др.);

Помимо этого, одним из направлений компании «ЭлектроПласт» является направление «Источники питания». Мы предлагаем Вам помощь Конструкторского отдела:

- Подбор оптимального решения, техническое обоснование при выборе компонента;
- Подбор аналогов;
- Консультации по применению компонента;
- Поставка образцов и прототипов;
- Техническая поддержка проекта;
- Защита от снятия компонента с производства.



#### Как с нами связаться

**Телефон:** 8 (812) 309 58 32 (многоканальный)

**Факс:** 8 (812) 320-02-42

**Электронная почта:** [org@eplast1.ru](mailto:org@eplast1.ru)

**Адрес:** 198099, г. Санкт-Петербург, ул. Калинина, дом 2, корпус 4, литера А.