

STAMPED AND FORMED CONTACTS, PG 1 of 2

Click on [blue underlined part numbers](#) to be taken to their spec sheets.

OPTIONS

PART NUMBER: [AT62-14-01XX](#)
DESCRIPTION: CONTACT, SOCKET, STAMPED, SIZE 16

MATERIAL:
 CONTACT BODY: COPPER ALLOY
 HOOD: STAINLESS STEEL
PLATING SUFFIX CODE:
 XX=22 NICKEL PLATING
 XX=44 GOLD PLATING
CONTACT GENERAL DATA SPECIFICATION: S2-15217
AVAILABLE CRIMPERS: ATT-16-00, MFX-3950 & MFX-3953
CRIMPER SPECIFICATIONS: S2-15223 & S2-15224
CRIMP INFORMATION DRAWING: S2-15221 & S2-15222
CONTACTS PER REEL: APPROX. 4000 (PARTIAL REELS AVAILABLE)



PART NUMBER: [AT62-16-01XX](#)
DESCRIPTION: CONTACT, SOCKET, STAMPED, SIZE 16

MATERIAL:
 CONTACT BODY: COPPER ALLOY
 HOOD: STAINLESS STEEL
PLATING SUFFIX CODE:
 XX=22 NICKEL PLATING
 XX=44 GOLD PLATING
CONTACT GENERAL DATA SPECIFICATION: S2-15217
AVAILABLE CRIMPERS: ATT-16-00, ATT-16-01, MFX-3950 & MFX-3953
CRIMPER SPECIFICATIONS: S2-15223 & S2-15224
CRIMP INFORMATION DRAWING: S2-15221 & S2-15222
CONTACTS PER REEL: APPROX. 4000 (PARTIAL REELS AVAILABLE)



PART NUMBER: [AT62-16-06XX](#)
DESCRIPTION: CONTACT, SOCKET, STAMPED, SIZE 16

MATERIAL:
 CONTACT BODY: COPPER ALLOY
 HOOD: STAINLESS STEEL
PLATING SUFFIX CODE:
 XX=22 NICKEL PLATING
 XX=44 GOLD PLATING
CONTACT GENERAL DATA SPECIFICATION: S2-15217
AVAILABLE CRIMPERS: ATT-16-01, MFX-3950 & MFX-3953
CRIMPER SPECIFICATIONS: S2-15223 & S2-15224
CRIMP INFORMATION DRAWING: S2-15221 & S2-15222
CONTACTS PER REEL: APPROX. 4000 (PARTIAL REELS AVAILABLE)



PART NUMBER: [AT60-14-01XX](#)
DESCRIPTION: CONTACT, PIN, STAMPED, SIZE 16

MATERIAL: COPPER ALLOY
PLATING SUFFIX CODE:
 XX=22 NICKEL PLATING
 XX=44 GOLD PLATING
CONTACT GENERAL DATA SPECIFICATION: S2-15217
AVAILABLE CRIMPERS: ATT-16-00, MFX-3950 & MFX-3953
CRIMPER SPECIFICATIONS: S2-15223 & S2-15224
CRIMP INFORMATION DRAWING: S2-15221 & S2-15222
CONTACTS PER REEL: APPROX. 4000 (PARTIAL REELS AVAILABLE)



STAMPED AND FORMED CONTACTS, PG 2 of 2

Click on [blue underlined part numbers](#) to be taken to their spec sheets.

OPTIONS

PART NUMBER: [AT60-16-01XX](#)
DESCRIPTION: CONTACT, PIN, STAMPED, SIZE 16
MATERIAL: COPPER ALLOY
PLATING SUFFIX CODE:
 XX=22 NICKEL PLATING
 XX=44 GOLD PLATING
CONTACT GENERAL DATA SPECIFICATION: S2-15217
AVAILABLE CRIMPERS: ATT-16-00, ATT-16-01, MFX-3950 & MFX-3953
CRIMPER SPECIFICATIONS: S2-15223 & S2-15224
CRIMP INFORMATION DRAWING: S2-15221 & S2-15222
CONTACTS PER REEL: APPROX. 4000 (PARTIAL REELS AVAILABLE)

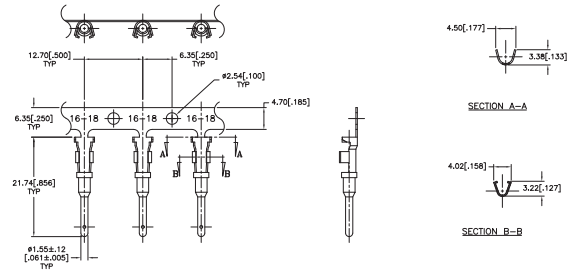

PART NUMBER: [AT60-16-06XX](#)
DESCRIPTION: CONTACT, PIN, STAMPED, SIZE 16
MATERIAL: COPPER ALLOY
PLATING SUFFIX CODE:
 XX=22 NICKEL PLATING
 XX=44 GOLD PLATING
CONTACT GENERAL DATA SPECIFICATION: S2-15217
AVAILABLE CRIMPERS: ATT-16-01, MFX-3950 & MFX-3953
CRIMPER SPECIFICATIONS: S2-15223 & S2-15224
CRIMP INFORMATION DRAWING: S2-15221 & S2-15222
CONTACTS PER REEL: APPROX. 4000 (PARTIAL REELS AVAILABLE)

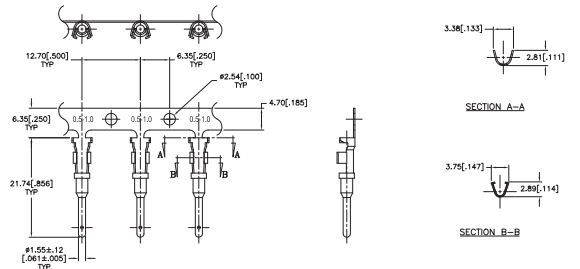

SOLID/MACHINED CONTACTS

Click on [blue underlined part numbers](#) to be taken to their spec sheets.

OPTIONS

MILITARY-STYLE

PART NUMBER: [AT60-202-16XX](#)
DESCRIPTION: CONTACT, PIN, SOLID MACHINED, SIZE 16
MATERIAL: COPPER ALLOY
PLATING SUFFIX CODE:
 XX=141 NICKEL PLATING
 XX=31 GOLD PLATING
CONTACT GENERAL DATA SPECIFICATION: S2-15217
AVAILABLE CRIMPERS: CA-5D12 & CA-5E12
CRIMPER SPECIFICATIONS: S2-15219 & S2-15220
CRIMP INFORMATION DRAWING: S2-15218



PART NUMBER: [AT62-201-16XX](#)
DESCRIPTION: CONTACT, SOCKET, SOLID MACHINED, SIZE 16
MATERIAL:
 CONTACT BODY: COPPER ALLOY
 HOOD: STAINLESS STEEL
PLATING SUFFIX CODE:
 XX=141 NICKEL PLATING
 XX=31 GOLD PLATING
CONTACT GENERAL DATA SPECIFICATION: S2-15217
AVAILABLE CRIMPERS: CA-5D12 & CA-5E12
CRIMPER SPECIFICATIONS: S2-15219 & S2-15220
CRIMP INFORMATION DRAWING: S2-15218



ROCKSOLID™ CONTACTS

PART NUMBER: [65-54942-14](#)
DESCRIPTION: CONTACT, SOCKET, ROCKSOLID, SIZE 16
AWG RANGE: 14AWG
MATERIAL: COPPER ALLOY
PLATING: GOLD
CONTACT GENERAL DATA SPECIFICATION: S2-15217
AVAILABLE CRIMPERS: CA-5D12 & CA-5E12
CRIMPER SPECIFICATIONS: S2-15219 & S2-15220
CRIMP INFORMATION DRAWING: S2-15218

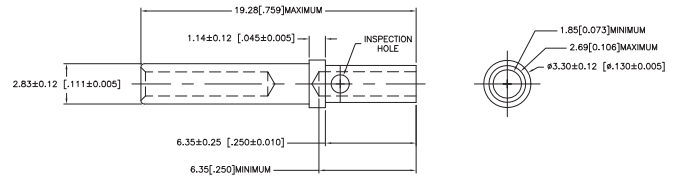

PART NUMBER: [65-54942-16](#)
DESCRIPTION: CONTACT, SOCKET, ROCKSOLID, SIZE 16
AWG RANGE: 16AWG
MATERIAL: COPPER ALLOY
PLATING: GOLD
CONTACT GENERAL DATA SPECIFICATION: S2-15217
AVAILABLE CRIMPERS: CA-5D12 & CA-5E12
CRIMPER SPECIFICATIONS: S2-15219 & S2-15220
CRIMP INFORMATION DRAWING: S2-15218



PART NUMBER: [65-54942-20](#)
DESCRIPTION: CONTACT, SOCKET, ROCKSOLID, SIZE 16
AWG RANGE: 20AWG
MATERIAL: COPPER ALLOY
PLATING: GOLD
CONTACT GENERAL DATA SPECIFICATION: S2-15217
AVAILABLE CRIMPERS: CA-5D12 & CA-5E12
CRIMPER SPECIFICATIONS: S2-15219 & S2-15220
CRIMP INFORMATION DRAWING: S2-15218

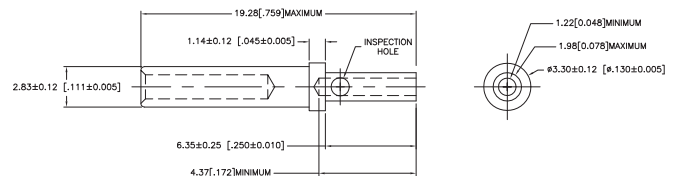

REVISIONS					
REV	ECO	DESCRIPTION	DATE	BY	APPR
A1	-	RELEASE NUMBER 016571	6/12/09	B.D.B.	M.R.F.

USE CRIMPER NUMBER:
ATT-16-00 WITH CAVITY A & B

CONTACT P/N:	INSULATION ϕ	CAVITY	WIRE SIZE
AT60-16-01**	.075 - .140	B	1.5mm ²
AT62-16-01**	[1.91 - 3.56]	A	16AWG
		A	1.0mm ²
AT60-14-01**	.095 - .150	B	14AWG
AT62-14-01**	[2.41 - 3.81]	B	2.0mm ²
		B	1.5mm ²
		A	1.5mm ²
		A	16AWG
		A	1.0mm ²
AT60-16-06**	.055 - .100	A	16AWG
AT62-16-06**	[1.40 - 2.54]	A	1.0mm ²

USE CRIMPER NUMBER:
ATT-16-01 WITH CAVITY C & D

CONTACT P/N:	INSULATION ϕ	CAVITY	WIRE SIZE
AT60-16-01**	.075 - .140	D	18AWG
AT62-16-01**	[1.91 - 3.56]	D	.75mm ²
AT60-16-06**	.055 - .100	D	18AWG
AT62-16-06**	[1.40 - 2.54]	D	.75mm ²
		C	.50mm ²

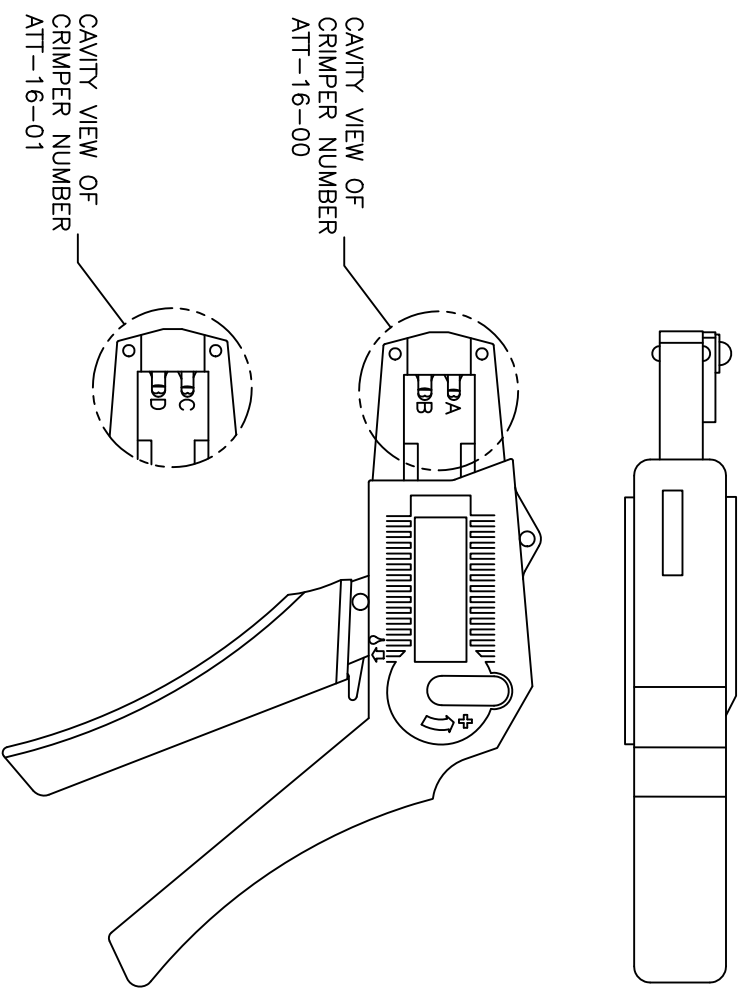

CAVITY VIEW OF
CRIMPER NUMBER
ATT-16-00

CAVITY VIEW OF
CRIMPER NUMBER
ATT-16-01

ALL REFERENCES TO DEUTSCH PRODUCTS OR SPECIFICATIONS ARE FOR COMPARISON PURPOSES ONLY, AND REFER TO DEUTSCH INDUSTRIAL PRODUCTS.

- NOTES (UNLESS OTHERWISE SPECIFIED):
- ALL DIMENSIONS IN INCHES [MILLIMETERS]
FOR PLATING CODES ** SEE CONTACT DATA DRAWINGS.
 - THIS TOOL IS FOR CRIMPING SIZE 16 CONTACTS ONLY TO WIRES LISTED IN THE CHARTS.
 - DEUTSCH IPD CROSS REFERENCE PART NUMBERS ARE DTT-16-00 AND DTT-16-01.

QUANTITY	PART NUMBER	DESCRIPTION	ITEM
MATERIALS LIST			
SINE Systems Corporation A Subsidiary of Amphenol Corporation 44724 Morley Drive Clinton Township, MI 48036			
INSTRUCTIONS: ATT-16-00 & 01 CRIMPER, HAND, STAMPED CONTACTS		SIZE: FSCM NO/DWG NO: B 16K44	REVISION: A1
SCALE: NONE		S2-15223	SHEET 1 OF 1

UNLESS OTHERWISE SPECIFIED	SIGNATURES	DATE
1) All dimensions are in inches.	DRAWN: BERNUW	6/8/09
2) Tolerances are as follows:	CHECKED: FORCE	6/8/09
3) 1st DEC 3.000	ENGINEER: BERNUW	
3) 2nd DEC 3.000	APPROVAL: BERNUW	6/8/09
3) 3rd DEC 3.000	CUSTOMER:	
4) Hole Reference = A		
INTERNAL SPECIFICATIONS:		
M/A		
PROCESS SPECIFICATIONS:		
NOT ASY:		

THE USE OF THIS DOCUMENT IS UNLIMITED. DESIGN FEATURES, SPECIFIC DATA SHOWN, METHOD AND THE PROPERTY OF AMPHENOL CORP. ALL DIMENSIONS ARE IN INCHES UNLESS OTHERWISE SPECIFIED.
DOCUMENTS REFERENCED HEREON ARE: DEUTSCH INDUSTRIAL CONTACT DATA.

REV ZONE		ECO	DESCRIPTION	DATE	BY	APP
AT	-	-	RELEASE NUMBER 016871	6/12/09	B.D.B.	M.F.F.

STAMPED CONTACT PART NUMBER 1068=PIN 1068=SOCKET	SIZE	CONDUCTOR WIRE SIZE	CRIMP HEIGHT	CRIMP WIDTH	CONDUCTOR PUNCH NUMBER	CONDUCTOR ANVIL NUMBER	CRIMP TENSILE REFERENCE
AT80-14-011x AT82-14-011x INSULATION RANGE 0.095-0.150(2.41-3.81)	16	14 AWG 2.00mm ² 1.50mm ² 16 AWG 1.00mm ² 18 AWG 0.75mm ²	0.055(1.40) 0.055(1.40) 0.055(1.39) 0.050(1.27) 0.049(1.24) 0.048(1.22)	±0.003 INCH [±0.08 mm]	AT17-002-0200	AT17-101-0200	28(111)
AT60-16-011x AT62-16-011x INSULATION RANGE 0.075-0.140(1.91-3.56)	16	14 AWG 2.00mm ² 1.50mm ² 16 AWG 1.00mm ² 18 AWG 0.75mm ²	0.051(1.40) 0.051(1.40) 0.051(1.39) 0.050(1.27) 0.049(1.24) 0.048(1.22)	±0.003 INCH [±0.08 mm]	AT17-003-0200	AT17-103-0200	28(111)
AT60-16-066x INSULATION RANGE 0.055-0.100(1.40-2.54)	16	16 AWG 1.00mm ² 0.75mm ² 20 AWG 0.50mm ²	0.050(1.27) 0.049(1.24) 0.048(1.22) 0.045(1.14)	±0.003 INCH [±0.08 mm]	AT17-003-0200	AT17-103-0200	28(111)

CROSS REFERENCE

SINE PART NUMBER	DEUTSCH PART NUMBER
MX-3950	DC116-02-00
AT17-002-0200	1017-002-0200
AT17-003-0200	1017-003-0200
AT17-101-0200	1017-101-0200
AT17-103-0200	1017-103-0200
AT17-210-0200	1017-210-0200
AT17-211-0200	1017-211-0200
AT17-213-0200	1017-213-0200
AT17-214-0200	1017-214-0200
AT17-217-0200	1017-217-0200
AT17-218-0200	1017-218-0200
AT17-310-0200	1017-310-0200
AT17-311-0200	1017-311-0200
AT17-313-0200	1017-313-0200
AT17-304-0200	1017-304-0200
AT17-317-0200	1017-317-0200
AT17-318-0200	1017-318-0200

NOTES: UNLESS OTHERWISE SPECIFIED

1. ALL DIMENSIONS ARE IN INCHES(mm).
2. FORCES ARE IN POUNDS(LBS) AND NEWTONS(N).
3. "X"= PLATING SUFFIX. SEE INDIVIDUAL CONTACT DRAWING.
4. WIRE STRIP LENGTH: 0.175±0.029(4.45±0.74). BROKEN OR MISSING CONDUCTOR STRANDS ARE NOT ACCEPTABLE.
5. USE A BLADE MICROMEETER (0.100(2.54) MIN SPACING AND 0.060(0.010(1.50)(0.040) ANVIL) TO MEASURE THE CONDUCTOR CRIMP. SEE SECTION AA.
6. CRIMP TENSILE STRENGTH IS DETERMINED AT A PULL RATE SPEED OF 1.00 INCH(25.4) PER MINUTE. INSULATION WINGS ARE REMOVED FOR TEST. ACTUAL CRIMP TENSILE STRENGTH DEPENDS ON WIRE/CONDUCTOR SIZE. VALUES ON THIS SPECIFICATION ARE FOR REFERENCE ONLY.
7. INSULATION DIAMETER RANGE IS DETERMINED BY CONNECTOR AND ITS WIRE SEAL SIZE. SEE CONNECTOR DRAWING FOR INSULATION RANGE.
8. INSULATION CRIMP DIAMETER SHOULD BE THE EQUAL OR LESS THAN THE DIAMETER OF THE WIRE INSULATION (HARD OR TEFION INSULATION MAY BE AN EXCEPTION). INSULATION CRIMP SHALL NOT AFFECT REMOVAL TOOL PERFORMANCE AND SHALL NOT DAMAGE CONNECTOR GROMMET SEAL.
9. CONDUCTOR TYPE ARE PER SAE J1128(AWG) AND ISO 6722(METRIC)
10. FOR CONTACT MATERIAL AND PERFORMANCE DATA, SEE DRAWING S2-15217.
11. REFER TO S2-15223 AND S2-15224 AND CROSS REFERENCE CHARTS FOR CRIMP TOOL DATA.

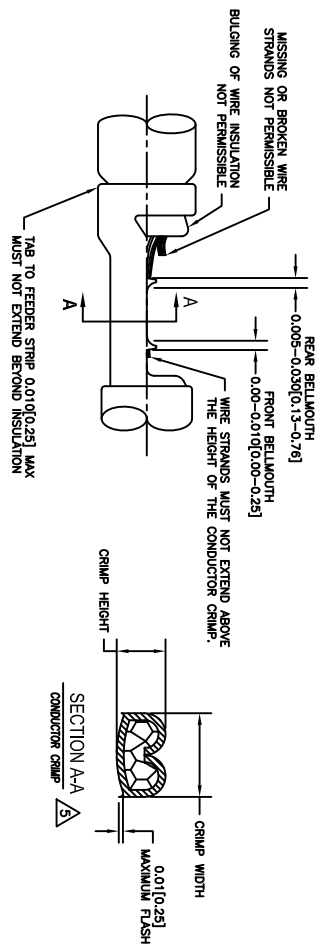
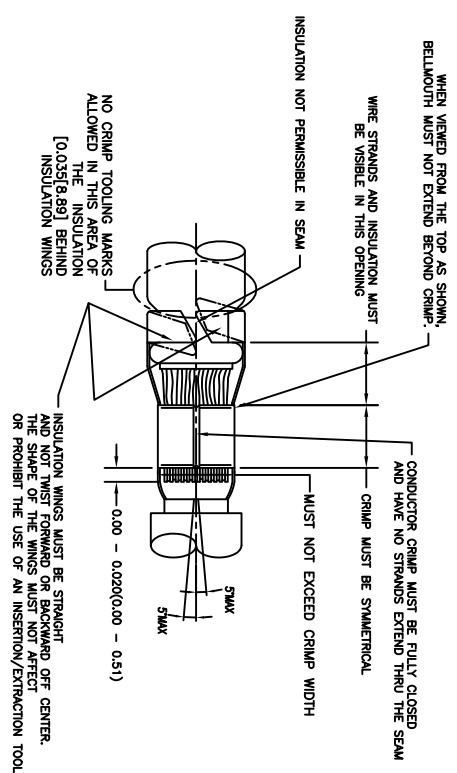

ALL REFERENCES TO DEUTSCH PRODUCTS OR SPECIFICATIONS ARE FOR COMPARISON PURPOSES ONLY, AND REFER TO DEUTSCH INDUSTRIAL PRODUCTS.

QUANTITY	PART NUMBER	MATERIALS LIST	DESCRIPTION	ITEM
UNLESS OTHERWISE SPECIFIED	SIGNATURES	DATE		
1) All dimensions are in inches.	DRAWN: POTER	4/7/09	SINE Systems Corporation	
2) All dimensions are in millimeters.	CHECKED: RONE	6/8/09	A Subsidiary of Amphenol Corporation	
3) Plating standards per Mil Spec 8830.	ENGINEER: BERLIN	6/8/09	44724 Moley Drive	
4) Plating standards per Mil Spec 8830.	APPROVAL: BERLIN	6/8/09	Clinton Township, MI 48036	
5) Reduction standards per Mil Spec 8830.	CUSTOMER:			
6) Plating standards per Mil Spec 8830.				
7) Plating standards per Mil Spec 8830.				
8) Plating standards per Mil Spec 8830.				
9) Plating standards per Mil Spec 8830.				
10) Plating standards per Mil Spec 8830.				
11) Plating standards per Mil Spec 8830.				
12) Plating standards per Mil Spec 8830.				
13) Plating standards per Mil Spec 8830.				
14) Plating standards per Mil Spec 8830.				
15) Plating standards per Mil Spec 8830.				
16) Plating standards per Mil Spec 8830.				
17) Plating standards per Mil Spec 8830.				
18) Plating standards per Mil Spec 8830.				
19) Plating standards per Mil Spec 8830.				
20) Plating standards per Mil Spec 8830.				
21) Plating standards per Mil Spec 8830.				
22) Plating standards per Mil Spec 8830.				
23) Plating standards per Mil Spec 8830.				
24) Plating standards per Mil Spec 8830.				
25) Plating standards per Mil Spec 8830.				
26) Plating standards per Mil Spec 8830.				
27) Plating standards per Mil Spec 8830.				
28) Plating standards per Mil Spec 8830.				
29) Plating standards per Mil Spec 8830.				
30) Plating standards per Mil Spec 8830.				
31) Plating standards per Mil Spec 8830.				
32) Plating standards per Mil Spec 8830.				
33) Plating standards per Mil Spec 8830.				
34) Plating standards per Mil Spec 8830.				
35) Plating standards per Mil Spec 8830.				
36) Plating standards per Mil Spec 8830.				
37) Plating standards per Mil Spec 8830.				
38) Plating standards per Mil Spec 8830.				
39) Plating standards per Mil Spec 8830.				
40) Plating standards per Mil Spec 8830.				
41) Plating standards per Mil Spec 8830.				
42) Plating standards per Mil Spec 8830.				
43) Plating standards per Mil Spec 8830.				
44) Plating standards per Mil Spec 8830.				
45) Plating standards per Mil Spec 8830.				
46) Plating standards per Mil Spec 8830.				
47) Plating standards per Mil Spec 8830.				
48) Plating standards per Mil Spec 8830.				
49) Plating standards per Mil Spec 8830.				
50) Plating standards per Mil Spec 8830.				
51) Plating standards per Mil Spec 8830.				
52) Plating standards per Mil Spec 8830.				
53) Plating standards per Mil Spec 8830.				
54) Plating standards per Mil Spec 8830.				
55) Plating standards per Mil Spec 8830.				
56) Plating standards per Mil Spec 8830.				
57) Plating standards per Mil Spec 8830.				
58) Plating standards per Mil Spec 8830.				
59) Plating standards per Mil Spec 8830.				
60) Plating standards per Mil Spec 8830.				
61) Plating standards per Mil Spec 8830.				
62) Plating standards per Mil Spec 8830.				
63) Plating standards per Mil Spec 8830.				
64) Plating standards per Mil Spec 8830.				
65) Plating standards per Mil Spec 8830.				
66) Plating standards per Mil Spec 8830.				
67) Plating standards per Mil Spec 8830.				
68) Plating standards per Mil Spec 8830.				
69) Plating standards per Mil Spec 8830.				
70) Plating standards per Mil Spec 8830.				
71) Plating standards per Mil Spec 8830.				
72) Plating standards per Mil Spec 8830.				
73) Plating standards per Mil Spec 8830.				
74) Plating standards per Mil Spec 8830.				
75) Plating standards per Mil Spec 8830.				
76) Plating standards per Mil Spec 8830.				
77) Plating standards per Mil Spec 8830.				
78) Plating standards per Mil Spec 8830.				
79) Plating standards per Mil Spec 8830.				
80) Plating standards per Mil Spec 8830.				
81) Plating standards per Mil Spec 8830.				
82) Plating standards per Mil Spec 8830.				
83) Plating standards per Mil Spec 8830.				
84) Plating standards per Mil Spec 8830.				
85) Plating standards per Mil Spec 8830.				
86) Plating standards per Mil Spec 8830.				
87) Plating standards per Mil Spec 8830.				
88) Plating standards per Mil Spec 8830.				
89) Plating standards per Mil Spec 8830.				
90) Plating standards per Mil Spec 8830.				
91) Plating standards per Mil Spec 8830.				
92) Plating standards per Mil Spec 8830.				
93) Plating standards per Mil Spec 8830.				
94) Plating standards per Mil Spec 8830.				
95) Plating standards per Mil Spec 8830.				
96) Plating standards per Mil Spec 8830.				
97) Plating standards per Mil Spec 8830.				
98) Plating standards per Mil Spec 8830.				
99) Plating standards per Mil Spec 8830.				
100) Plating standards per Mil Spec 8830.				

REVISIONS						
REV	ZONE	ECO	DESCRIPTION	DATE	BY	APP
A1	-	-	RELEASE NUMBER 016971	6/12/09	B.D.B.	M.F.F.

STAMPED CONTACT PART NUMBER (1009=PIN 1009=SOCKET)	SIZE	CONDUCTOR WIRE SIZE	CRIMP HEIGHT +0.001/-0.002 INCH (+0.025/-0.05 mm)	CRIMP WIDTH ±0.003 INCH (±0.08 mm)	CONDUCTOR PUNCH NUMBER	CONDUCTOR ANVIL NUMBER	CRIMP TENSILE REFERENCE (LBS/IN)
A160-14-011x A162-14-011x INSULATION RANGE 0.095-0.150(2.41-3.81)	16	14 AWG 2.00mm ² 1.50mm ² 16 AWG 1.00mm ² 18 AWG 0.75mm ²	0.0591(1.40) 0.0591(1.40) 0.0591(1.40) 0.0501(1.27) 0.0491(1.24) 0.0491(1.24)	0.094(2.39) 0.094(2.39) 0.094(2.39) 0.084(2.39) 0.084(2.39) 0.084(2.39)		A117-4083-0200 A117-183-0200	29(111)
A160-16-011x A162-16-011x INSULATION RANGE 0.075-0.140(1.91-3.59)	16	14 AWG 2.00mm ² 1.50mm ² 16 AWG 1.00mm ² 18 AWG 0.75mm ²	0.0591(1.40) 0.0591(1.40) 0.0591(1.40) 0.0501(1.27) 0.0491(1.24) 0.0491(1.24)	0.094(2.39) 0.094(2.39) 0.094(2.39) 0.084(2.39) 0.084(2.39) 0.084(2.39)		A117-4083-0200 A117-183-0200	29(111)
A160-16-066x A162-16-066x INSULATION RANGE 0.055-0.100(1.40-2.54)	16	16 AWG 1.00mm ² 0.75mm ² 20 AWG 0.50mm ²	0.0591(1.27) 0.0591(1.27) 0.0491(1.24) 0.0491(1.24) 0.0491(1.41)	0.079(2.01) 0.079(2.01) 0.079(2.01) 0.079(2.01) 0.079(2.01)		A117-4082-0200 A117-182-0200	29(111) 19(67)

CROSS REFERENCE

INSULATION DIAMETER RANGE	INSULATION PUNCH NUMBER	INSULATION ANVIL NUMBER	SINE PART NUMBER	DEUTSCH PART NUMBER
0.120-0.150 [3.05-3.81]	A117-225-0200	A117-326-0200	MPX-3953	DCT1620-02-00
0.105-0.125 [2.67-3.18]	A117-226-0200	A117-326-0200	A117-083-0200	1017-083-0200
0.085-0.111 [2.16-2.82]	A117-227-0200	A117-327-0200	A117-082-0200	1017-082-0200
0.075-0.105 [1.91-2.67]	A117-228-0200	A117-328-0200	A117-183-0200	1017-183-0200
0.063-0.094 [1.62-2.39]	A117-229-0200	A117-329-0200	A117-182-0200	1017-182-0200
0.050-0.075 [1.27-1.91]	A117-230-0200	A117-330-0200	A117-225-0200	1017-225-0200
			A117-226-0200	1017-226-0200
			A117-227-0200	1017-227-0200
			A117-228-0200	1017-228-0200
			A117-229-0200	1017-229-0200
			A117-230-0200	1017-230-0200
			A117-325-0200	1017-325-0200
			A117-326-0200	1017-326-0200
			A117-327-0200	1017-327-0200
			A117-328-0200	1017-328-0200
			A117-329-0200	1017-329-0200
			A117-330-0200	1017-330-0200

NOTES: UNLESS OTHERWISE SPECIFIED

1. ALL DIMENSIONS ARE IN INCHES(mm).
2. FORCES ARE IN POUNDS(LBS) AND NEWTONS(N).
3. "X"= PLATING SUFFIX. SEE INDIVIDUAL CONTACT DRAWING.
4. WIRE STRIP LENGTH: 0.175±0.029(4.43±0.74). BROKEN OR MISSING CONDUCTOR STRANDS ARE NOT ACCEPTABLE. USE A BLADE MICROMETER (0.100[2.54] MIN SPINDLE AND 0.060[0.010][1.50][0.040] ANVIL) TO MEASURE THE CONDUCTOR CRIMP. SEE SECTION AA.
5. CRIMP TENSILE STRENGTH IS DETERMINED AT A PULL RATE SPEED OF 1.00 INCH(2.54) PER MINUTE. INSULATION WINGS ARE REMOVED FOR TEST. ACTUAL CRIMP TENSILE STRENGTH DEPENDS ON WIRE/CONDUCTOR SIZE. VALUES ON THIS SPECIFICATION ARE FOR REFERENCE ONLY.
6. INSULATION DIAMETER RANGE IS DETERMINED BY CONNECTOR AND ITS WIRE SEAL SIZE. SEE CONNECTOR DRAWING FOR INSULATION RANGE.
7. INSULATION CRIMP DIAMETER SHOULD BE THE EQUAL OR LESS THAN THE DIAMETER OF THE WIRE INSULATION (HARD OR TEFION INSULATION MAY BE AN EXCEPTION). INSULATION CRIMP SHALL NOT AFFECT REMOVAL TOOL PERFORMANCE AND SHALL NOT DAMAGE CONNECTOR GROMMET SEAL.
8. CONDUCTOR TYPE ARE PER SAE J1128(AWG) AND ISO 6122(METRIC)
9. FOR CONTACT MATERIAL AND PERFORMANCE DATA, SEE DRAWING S2-15217.
10. REFER TO S2-15223 AND S2-15224 AND CROSS REFERENCE CHARTS FOR CRIMP TOOL DATA.

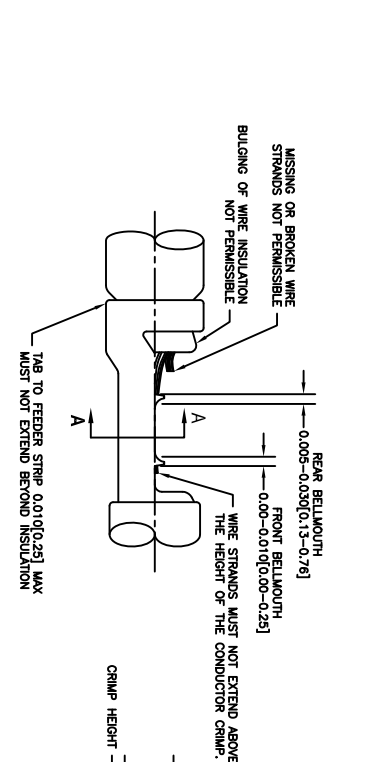
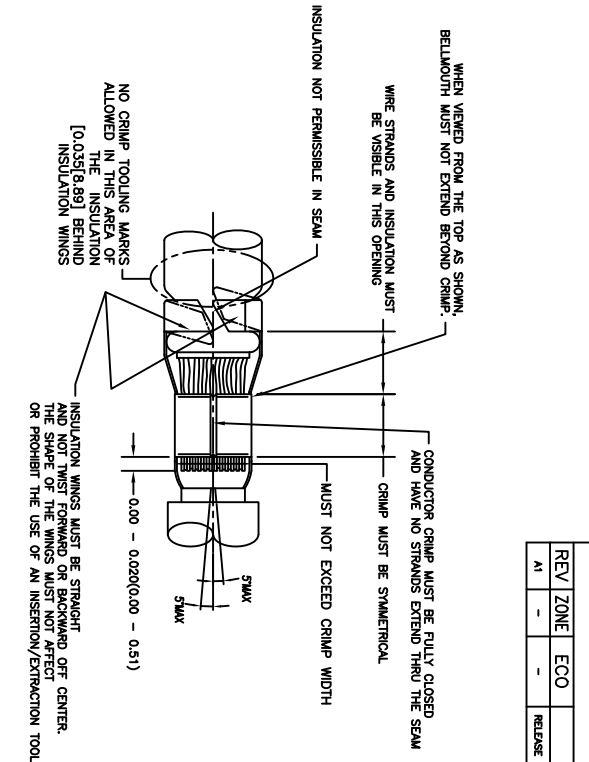

ALL REFERENCES TO DEUTSCH PRODUCTS OR SPECIFICATIONS ARE FOR COMPARISON PURPOSES ONLY, AND REFER TO DEUTSCH INDUSTRIAL PRODUCTS.

QUANTITY	PART NUMBER	MATERIALS LIST	DESCRIPTION	ITEM
UNLESS OTHERWISE SPECIFIED	SIGNATURES	DATE		
1) All dimensions are in inches.	DATE	4/7/09		
2) All dimensions are in millimeters.	DATE	6/8/09		
3) Production Standard Per: Alpha S1*	ENGINEER	BERNIM		
4) Form: S2-20020	APPROVAL	BERNIM	6/8/09	
5) Material Specification:	CUSTOMER			
6) Material Specification:				
7) Material Specification:				
8) Material Specification:				
9) Material Specification:				
10) Material Specification:				
11) Material Specification:				
12) Material Specification:				
13) Material Specification:				
14) Material Specification:				
15) Material Specification:				
16) Material Specification:				
17) Material Specification:				
18) Material Specification:				
19) Material Specification:				
20) Material Specification:				
21) Material Specification:				
22) Material Specification:				
23) Material Specification:				
24) Material Specification:				
25) Material Specification:				
26) Material Specification:				
27) Material Specification:				
28) Material Specification:				
29) Material Specification:				
30) Material Specification:				
31) Material Specification:				
32) Material Specification:				
33) Material Specification:				
34) Material Specification:				
35) Material Specification:				
36) Material Specification:				
37) Material Specification:				
38) Material Specification:				
39) Material Specification:				
40) Material Specification:				
41) Material Specification:				
42) Material Specification:				
43) Material Specification:				
44) Material Specification:				
45) Material Specification:				
46) Material Specification:				
47) Material Specification:				
48) Material Specification:				
49) Material Specification:				
50) Material Specification:				
51) Material Specification:				
52) Material Specification:				
53) Material Specification:				
54) Material Specification:				
55) Material Specification:				
56) Material Specification:				
57) Material Specification:				
58) Material Specification:				
59) Material Specification:				
60) Material Specification:				
61) Material Specification:				
62) Material Specification:				
63) Material Specification:				
64) Material Specification:				
65) Material Specification:				
66) Material Specification:				
67) Material Specification:				
68) Material Specification:				
69) Material Specification:				
70) Material Specification:				
71) Material Specification:				
72) Material Specification:				
73) Material Specification:				
74) Material Specification:				
75) Material Specification:				
76) Material Specification:				
77) Material Specification:				
78) Material Specification:				
79) Material Specification:				
80) Material Specification:				
81) Material Specification:				
82) Material Specification:				
83) Material Specification:				
84) Material Specification:				
85) Material Specification:				
86) Material Specification:				
87) Material Specification:				
88) Material Specification:				
89) Material Specification:				
90) Material Specification:				
91) Material Specification:				
92) Material Specification:				
93) Material Specification:				
94) Material Specification:				
95) Material Specification:				
96) Material Specification:				
97) Material Specification:				
98) Material Specification:				
99) Material Specification:				
100) Material Specification:				

<p>SINE Systems Corporation A Subsidiary of Amphenol Corporation 44724 Moley Drive Clinton Township, MI 48036</p>	<p>CRIMP DATA, STAMPED CONTACTS FOR CRIMPER MPX-3953</p>
--	---

REVOLUTIONS		DESCRIPTION	DATE	BY	APPR
REV	ZONE	ECO	RELEASE NUMBER 016571	B.D.B.	M.R.F.
1	-	-	6/12/09		

CONTACT LOCATOR "TURRET"
THREE POSITION FOR SIZE
12, 16 & 20 MALE AND
FEMALE CONTACTS

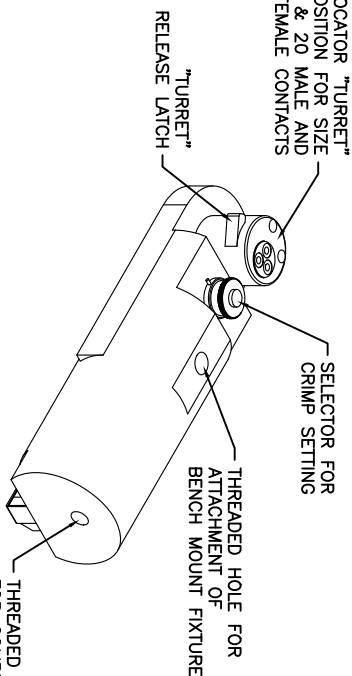
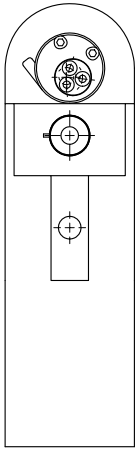

THREADED OPENING
FOR COMPRESSED
AIR FITTING

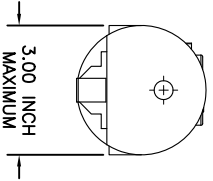

- NOTES:
1. THE CA-5E12 IS A COMPRESSED AIR OPERATED HAND CRIMPER FOR ELECTRICAL CONTACTS. IT IS ADJUSTABLE TO 3 CONTACT SIZES (12, 16 & 20) AND 8 INDENTER CRIMP POSITIONS FOR DIFFERENT WIRE SIZES (12AWG THRU 26 AWG).
 2. 80-120 PSI COMPRESSED AIR.
 3. WEIGHT: 3.1 LBS
 4. SELECTING CONTACT SIZE: PRESS THE RELEASE LATCH ON SIDE OF THE CONTACT LOCATOR "TURRET". ROTATE TO THE DESIRED CONTACT SIZE. THE TOP OF THE "TURRET" IS EMBOSSED WITH THE CONTACT SIZES.
 5. SELECTING WIRE SIZE: GRASP THE SELECTOR AND ROTATE TO THE DESIRED NUMBER.

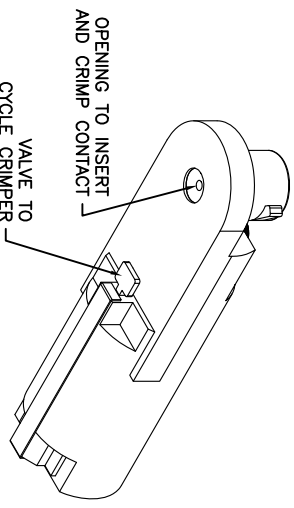

GAGE PART NO.	A GO DIA.	B NO-GO DIA.	SELECTOR NUMBER
G125	.0390	.0440	4

GAGING INSTRUCTIONS

CAUTION!
DO NOT CRIMP GAGE!

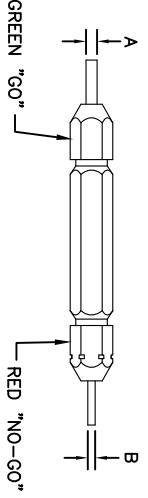

"GO" GAGING: OPERATE TOOL TO FULLY CLOSED POSITION. INSERT "GO" GAGE END AS SHOWN. GAGE MUST PASS FREELY BETWEEN INDENTER TIPS.

"NO-GO" GAGING: OPERATE TOOL TO FULLY CLOSED POSITION. INSERT "NO-GO" GAGE END AS SHOWN. THE "NO-GO" MAY PARTIALLY ENTER THE INDENTER OPENING, BUT MUST NOT PASS COMPLETELY THROUGH THE OPENING.

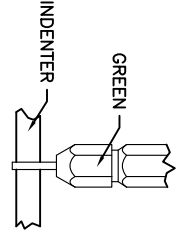

SELECTOR NUMBER	A GO DIA.	B NO-GO DIA.
1	.0280	.0330
2	.0320	.0370
3	.0360	.0410
4	.0390	.0440
5	.0450	.0500
6	.0520	.0570
7	.0590	.0640
8	.0680	.0730

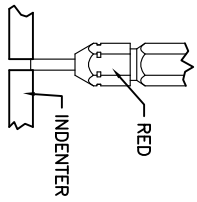

CONTACT SIZE	LOCATOR "TURRET" POSITION COLOR	26 AWG WIRE	24 AWG WIRE	22 AWG WIRE	20 AWG WIRE	18 AWG WIRE	16 AWG WIRE	14 AWG WIRE	12 AWG WIRE
20-20	RED	1	2	3	4				
16-22	BLUE	4	5	6					
16-20	BLUE	1	2	3	4				
16-16	BLUE				4	5	6		
12-16	YELLOW				4	5	6		
12-12	YELLOW							7	8

QUANTITY PART NUMBER MATERIALS LIST DESCRIPTION ITEM

UNLESS OTHERWISE SPECIFIED	SIGNATURES	DATE
1) All dimensions are in inches.	DESIGNER: BERNIM	6/2/09
2) Pl. DEC 2000 1 Position 31/4"	CHECKER: NONE	6/3/09
3) Pl. DEC 2000 1 Position 31/4"	ENGINEER: BERNIM	6/3/09
4) Pl. DEC 2000 1 Position 31/4"	APPROVAL: BERNIM	6/3/09
5) Revision Standard Per: A	CUSTOMER:	
6) Title: SS-20020		
7) Material Specification:		
8) Material Specification:		
9) Material Specification:		
10) Material Specification:		
11) Material Specification:		
12) Material Specification:		
13) Material Specification:		
14) Material Specification:		
15) Material Specification:		
16) Material Specification:		
17) Material Specification:		
18) Material Specification:		
19) Material Specification:		
20) Material Specification:		
21) Material Specification:		
22) Material Specification:		
23) Material Specification:		
24) Material Specification:		
25) Material Specification:		
26) Material Specification:		
27) Material Specification:		
28) Material Specification:		
29) Material Specification:		
30) Material Specification:		
31) Material Specification:		
32) Material Specification:		
33) Material Specification:		
34) Material Specification:		
35) Material Specification:		
36) Material Specification:		
37) Material Specification:		
38) Material Specification:		
39) Material Specification:		
40) Material Specification:		
41) Material Specification:		
42) Material Specification:		
43) Material Specification:		
44) Material Specification:		
45) Material Specification:		
46) Material Specification:		
47) Material Specification:		
48) Material Specification:		
49) Material Specification:		
50) Material Specification:		
51) Material Specification:		
52) Material Specification:		
53) Material Specification:		
54) Material Specification:		
55) Material Specification:		
56) Material Specification:		
57) Material Specification:		
58) Material Specification:		
59) Material Specification:		
60) Material Specification:		
61) Material Specification:		
62) Material Specification:		
63) Material Specification:		
64) Material Specification:		
65) Material Specification:		
66) Material Specification:		
67) Material Specification:		
68) Material Specification:		
69) Material Specification:		
70) Material Specification:		
71) Material Specification:		
72) Material Specification:		
73) Material Specification:		
74) Material Specification:		
75) Material Specification:		
76) Material Specification:		
77) Material Specification:		
78) Material Specification:		
79) Material Specification:		
80) Material Specification:		
81) Material Specification:		
82) Material Specification:		
83) Material Specification:		
84) Material Specification:		
85) Material Specification:		
86) Material Specification:		
87) Material Specification:		
88) Material Specification:		
89) Material Specification:		
90) Material Specification:		
91) Material Specification:		
92) Material Specification:		
93) Material Specification:		
94) Material Specification:		
95) Material Specification:		
96) Material Specification:		
97) Material Specification:		
98) Material Specification:		
99) Material Specification:		
100) Material Specification:		

SINE Systems Corporation
A Subsidiary of Amphenol Corporation
44724 Mowley Drive
Carlton Township, MI 48036

INSTRUCTIONS FOR CA-5E12
CRIMPER, PNEUMATIC

SIZE: 10K44
SCALE: NONE
S2-15220
SHEET: 1 OF 1

REV ZONE		ECO		REVISIONS		DESCRIPTION	DATE	BY	APPR
AI	-	-	-	RELEASE NUMBER	016571		6/12/09	B.D.B.	M.R.F.

CONTACT LOCATOR
"TURRET"
THREE POSITIONS FOR
SIZE 12, 16 & 20 MALE
AND FEMALE CONTACTS

"TURRET" RELEASE LATCH

6.25 INCH
MAXIMUM
OPEN

2.30 INCH
MAXIMUM
CLOSED

SELECTOR FOR CRIMP
SETTING

1.125 INCH MAX.

9.75 INCH MAXIMUM

1.00 INCH MAX.

- NOTES:
- THE CA-5D12 IS A HAND OPERATED CRIMPER FOR ELECTRICAL CONTACTS. IT IS ADJUSTABLE TO 3 CONTACT SIZES (12, 16 & 20) AND 8 INDENTER CRIMP POSITIONS FOR DIFFERENT WIRE SIZES (12AWG THRU 26 AWG).
 - WEIGHT: 1.64 LBS
 - SELECTING CONTACT SIZE: PRESS THE RELEASE LATCH ON SIDE OF THE CONTACT LOCATOR "TURRET". ROTATE TO THE DESIRED CONTACT SIZE. THE TOP OF THE "TURRET" IS EMBOSSED WITH THE CONTACT SIZES.
 - SELECTING WIRE SIZE: REMOVE THE LOCKING CLIP. GRASP THE SELECTOR AND ROTATE TO THE DESIRED NUMBER.

GAGE PART NO.	A GO DIA.	B NO-GO DIA.	SELECTOR NUMBER
G125	.0390	.0440	4

GAGING INSTRUCTIONS

CAUTION!
DO NOT CRIMP GAGE!

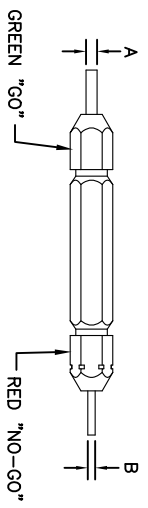

"GO" GAGING: OPERATE TOOL TO FULLY CLOSED POSITION. INSERT "GO" GAGE END AS SHOWN. GAGE MUST PASS FREELY BETWEEN INDENTER TIPS.

"NO-GO" GAGING: OPERATE TOOL TO FULLY CLOSED POSITION. INSERT "NO-GO" GAGE END AS SHOWN. THE "NO-GO" MAY PARTIALLY ENTER THE INDENTER OPENING, BUT MUST NOT PASS COMPLETELY THROUGH THE OPENING.

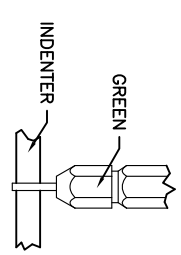

SELECTOR NUMBER	A GO DIA.	B NO-GO DIA.
1	.0280	.0330
2	.0320	.0370
3	.0360	.0410
4	.0390	.0440
5	.0450	.0500
6	.0520	.0570
7	.0590	.0640
8	.0880	.0730

CONTACT SIZE	LOCATOR "TURRET" POSITION	WIRE COLOR	1	2	3	4	5	6	7	8
20-20	RED	1	2	3	4					
16-22	BLUE	4	5	6						
16-20	BLUE	1	2	3	4					
16-16	BLUE	4	5	6						
12-16	YELLOW	4	5	6						
12-12	YELLOW									8

QUANTITY PART NUMBER MATERIALS LIST DESCRIPTION ITEM

UNLESS OTHERWISE SPECIFIED
1) All dimensions are in inches.
2) Pl. DEC 2000
3) Pl. DEC 2000
4) Pl. DEC 2000
5) Pl. DEC 2000
6) Pl. DEC 2000
7) Pl. DEC 2000
8) Pl. DEC 2000
9) Pl. DEC 2000
10) Pl. DEC 2000
11) Pl. DEC 2000
12) Pl. DEC 2000
13) Pl. DEC 2000
14) Pl. DEC 2000
15) Pl. DEC 2000
16) Pl. DEC 2000
17) Pl. DEC 2000
18) Pl. DEC 2000
19) Pl. DEC 2000
20) Pl. DEC 2000
21) Pl. DEC 2000
22) Pl. DEC 2000
23) Pl. DEC 2000
24) Pl. DEC 2000
25) Pl. DEC 2000
26) Pl. DEC 2000
27) Pl. DEC 2000
28) Pl. DEC 2000
29) Pl. DEC 2000
30) Pl. DEC 2000
31) Pl. DEC 2000
32) Pl. DEC 2000
33) Pl. DEC 2000
34) Pl. DEC 2000
35) Pl. DEC 2000
36) Pl. DEC 2000
37) Pl. DEC 2000
38) Pl. DEC 2000
39) Pl. DEC 2000
40) Pl. DEC 2000
41) Pl. DEC 2000
42) Pl. DEC 2000
43) Pl. DEC 2000
44) Pl. DEC 2000
45) Pl. DEC 2000
46) Pl. DEC 2000
47) Pl. DEC 2000
48) Pl. DEC 2000
49) Pl. DEC 2000
50) Pl. DEC 2000
51) Pl. DEC 2000
52) Pl. DEC 2000
53) Pl. DEC 2000
54) Pl. DEC 2000
55) Pl. DEC 2000
56) Pl. DEC 2000
57) Pl. DEC 2000
58) Pl. DEC 2000
59) Pl. DEC 2000
60) Pl. DEC 2000
61) Pl. DEC 2000
62) Pl. DEC 2000
63) Pl. DEC 2000
64) Pl. DEC 2000
65) Pl. DEC 2000
66) Pl. DEC 2000
67) Pl. DEC 2000
68) Pl. DEC 2000
69) Pl. DEC 2000
70) Pl. DEC 2000
71) Pl. DEC 2000
72) Pl. DEC 2000
73) Pl. DEC 2000
74) Pl. DEC 2000
75) Pl. DEC 2000
76) Pl. DEC 2000
77) Pl. DEC 2000
78) Pl. DEC 2000
79) Pl. DEC 2000
80) Pl. DEC 2000
81) Pl. DEC 2000
82) Pl. DEC 2000
83) Pl. DEC 2000
84) Pl. DEC 2000
85) Pl. DEC 2000
86) Pl. DEC 2000
87) Pl. DEC 2000
88) Pl. DEC 2000
89) Pl. DEC 2000
90) Pl. DEC 2000
91) Pl. DEC 2000
92) Pl. DEC 2000
93) Pl. DEC 2000
94) Pl. DEC 2000
95) Pl. DEC 2000
96) Pl. DEC 2000
97) Pl. DEC 2000
98) Pl. DEC 2000
99) Pl. DEC 2000
100) Pl. DEC 2000

SINE Systems Corporation
A Subsidiary of Amphenol Corporation
44724 Moley Drive
Canton Township, MI 48036

INSTRUCTIONS FOR CA-5D12
CRIMPER, HAND, MACHINED CONTACTS

SIZE: 10K44
SCALE: NONE
S2-15219
SHEET: 1 OF 1

REVISONS			
REV ZONE	ECO	DESCRIPTION	DATE
A1	-	RELEASE NUMBER 016971	6/12/09
			BY B.D.B.
			APPR M.R.F.

SOLID CONTACT SIZE	SOLID CONTACT PART NUMBERS		WIRE SIZE AVG (mm ²)	RECOMMENDED STRIP LENGTH INCH (mm)	MIN CONTACT RETENTION LBS (N)	REF CRIMP TENSILE LBS (N)	MAX RATED AMPS @ 125°C CONTINUOUS
	PN	SOCKET					
16	AT60-202-16**	AT62-201-16**	16-20 [1.5-0.5]	0.25-0.31 [6.35-7.92]	25 [1111]	35-20 [156-89]	13

S&P CONTACT SIZE	STAMPED CONTACT PART NUMBERS		WIRE SIZE AVG (mm ²)	WIRE INSULATION O.D. RANGE	RECOMMENDED STRIP LENGTH INCH (mm)	MIN CONTACT RETENTION LBS (N)	REF CRIMP TENSILE LBS (N)	MAX RATED AMPS @ 125°C CONTINUOUS
	PN	SOCKET						
16	AT60-14-01**	AT62-14-01**	14-16 [2.0-1.0]	.100 - .150 [2.54 - 3.81]	0.150-0.200 [3.81-5.08]	25 [1111]	25 [1111]	13
16	AT60-16-01**	AT62-16-01**	16-18 [1.0-0.75]	.075 - .100 [1.90 - 2.54]	0.150-0.200 [3.81-5.08]	25 [1111]	25 [1111]	13
16	AT60-16-06**	AT62-16-06**	18-20 [0.75-0.50]	.055 - .095 [1.40 - 2.41]	0.150-0.200 [3.81-5.08]	25 [1111]	25-15 [111+67]	13

CONTACT RESISTANCE STRENGTH (LESS DROP THROUGH WIRE)			
WIRE AWG	TEST CURRENT	MILLIVOLT DROP SOLID	MILLIVOLT DROP S&P
14	18	60	100
16	13	60	100
18	10	60	100
20	7.5	60	100

MATERIAL SPECIFICATION AND PLATING ** CODES	
PN: COPPER ALLOY	SOLID MACHINED CONTACT PLATING OPTIONS: Δ
SOCKET: COPPER ALLOY WITH STAINLESS STEEL SLEEVE	31= GOLD*
	141= NICKEL
	STAMPED CONTACT PLATING OPTIONS: Δ
	22= NICKEL
	44= GOLD*
	89= SELECTIVE GOLD*
GOLD* = PLATING IS AVAILABLE (RECOMMENDED) FOR ONLY (<5V) CIRCUIT APPLICATIONS	
MATERIALS AND PLATINGS ARE ROHS COMPLIANT	

NOTES: UNLESS OTHERWISE SPECIFIED

1. ALL DIMENSIONS ARE INCHES(MM).
2. ALL FORCES ARE IN LBS(POUNDS) AND "N" (NEWTONS).
3. CONTACT RETENTION TEST PULL RATE SHALL BE 1.0 INCH/25.4 PER MINUTE MAXIMUM. WIRE SIZE WILL AFFECT THE TRUE STRENGTH OF THE CRIMP.
4. WIRE SIZES AND INSULATION RANGES ARE FOR REFERENCE ONLY. THE ACTUAL INSULATION RANGE DEPENDS ON CONNECTOR GROMMET SEALING SIZE.

SEE SPECIFICATIONS LISTED BELOW FOR INDIVIDUAL CRIMP INFORMATION:

"SOLID" CONTACTS	SIZE	"STAMPED" CONTACTS	SIZE
	S2-15218	S2-15222	16
		S2-15221	16/20

1. MAXIMUM RATED CURRENT IN CHART DEPENDS ON CONTACT SIZE. ACTUAL RATED CURRENT DEPENDS ON WIRE SIZE.
2. CONTACT FACTORY FOR ALL AVAILABLE PLATING ON SPECIFIC CONTACTS.
3. AMPHENOL SINE PERFORMANCE SPECIFICATIONS REQUIRE THE USE OF AMPHENOL SINE APPROVED TOOLING.

QUANTITY		PART NUMBER		DESCRIPTION		ITEM
UNLESS OTHERWISE SPECIFIED						
1) All dimensions are in inches.	SIGNATURES	DATE	MATERIALS LIST			
2) Pl. SEE 30.00	DATE	4/5/09	SINE Systems Corporation			
3) Pl. SEE 30.00	ORDERED	6/3/09	A Subsidiary of Amphenol Corporation			
4) Fabrication Standards Per:	ENGINEER	BERNIE	44724 Moley Drive			
5) Pl. SEE 30.00	APPROVAL	6/3/09	Carlton Township, MI 48036			
6) Pl. SEE 30.00	CUSTOMER		GENERAL DATA, CONTACTS			
7) Pl. SEE 30.00	APPROVAL		STAMPED AND FORMED / MACHINED			
8) Pl. SEE 30.00	CUSTOMER		SIZE (PICK NUMBER) S2-15217			
9) Pl. SEE 30.00	CUSTOMER		SCALE NONE			
10) Pl. SEE 30.00	CUSTOMER		SHEET 1 OF 1			
11) Pl. SEE 30.00	CUSTOMER		REVISION A1			
12) Pl. SEE 30.00	CUSTOMER		DRAWING NO. S2-15217			
13) Pl. SEE 30.00	CUSTOMER		CONTACT DATA, GENERAL			
14) Pl. SEE 30.00	CUSTOMER		TITLE			



Компания «ЭлектроПласт» предлагает заключение долгосрочных отношений при поставках импортных электронных компонентов на взаимовыгодных условиях!

Наши преимущества:

- Оперативные поставки широкого спектра электронных компонентов отечественного и импортного производства напрямую от производителей и с крупнейших мировых складов;
- Поставка более 17-ти миллионов наименований электронных компонентов;
- Поставка сложных, дефицитных, либо снятых с производства позиций;
- Оперативные сроки поставки под заказ (от 5 рабочих дней);
- Экспресс доставка в любую точку России;
- Техническая поддержка проекта, помощь в подборе аналогов, поставка прототипов;
- Система менеджмента качества сертифицирована по Международному стандарту ISO 9001;
- Лицензия ФСБ на осуществление работ с использованием сведений, составляющих государственную тайну;
- Поставка специализированных компонентов (Xilinx, Altera, Analog Devices, Intersil, Interpoint, Microsemi, Aeroflex, Peregrine, Syfer, Eurofarad, Texas Instrument, Miteq, Cobham, E2V, MA-COM, Hittite, Mini-Circuits, General Dynamics и др.);

Помимо этого, одним из направлений компании «ЭлектроПласт» является направление «Источники питания». Мы предлагаем Вам помощь Конструкторского отдела:

- Подбор оптимального решения, техническое обоснование при выборе компонента;
- Подбор аналогов;
- Консультации по применению компонента;
- Поставка образцов и прототипов;
- Техническая поддержка проекта;
- Защита от снятия компонента с производства.



Как с нами связаться

Телефон: 8 (812) 309 58 32 (многоканальный)

Факс: 8 (812) 320-02-42

Электронная почта: org@eplast1.ru

Адрес: 198099, г. Санкт-Петербург, ул. Калинина, дом 2, корпус 4, литера А.