

STAMPED AND FORMED CONTACTS, PG 1 of 2

Click on [blue underlined part numbers](#) to be taken to their spec sheets.

OPTIONS

PART NUMBER: [AT62-14-01XX](#)
DESCRIPTION: CONTACT, SOCKET, STAMPED, SIZE 16

MATERIAL:
 CONTACT BODY: COPPER ALLOY
 HOOD: STAINLESS STEEL
PLATING SUFFIX CODE:
 XX=22 NICKEL PLATING
 XX=44 GOLD PLATING
CONTACT GENERAL DATA SPECIFICATION: S2-15217
AVAILABLE CRIMPERS: ATT-16-00, MFX-3950 & MFX-3953
CRIMPER SPECIFICATIONS: S2-15223 & S2-15224
CRIMP INFORMATION DRAWING: S2-15221 & S2-15222
CONTACTS PER REEL: APPROX. 4000 (PARTIAL REELS AVAILABLE)

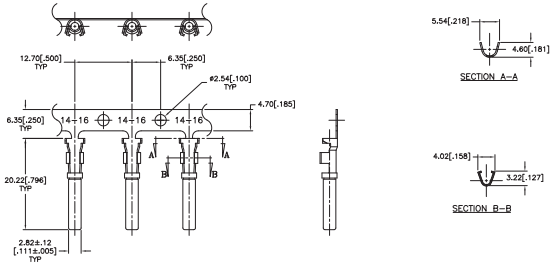

PART NUMBER: [AT62-16-01XX](#)
DESCRIPTION: CONTACT, SOCKET, STAMPED, SIZE 16

MATERIAL:
 CONTACT BODY: COPPER ALLOY
 HOOD: STAINLESS STEEL
PLATING SUFFIX CODE:
 XX=22 NICKEL PLATING
 XX=44 GOLD PLATING
CONTACT GENERAL DATA SPECIFICATION: S2-15217
AVAILABLE CRIMPERS: ATT-16-00, ATT-16-01, MFX-3950 & MFX-3953
CRIMPER SPECIFICATIONS: S2-15223 & S2-15224
CRIMP INFORMATION DRAWING: S2-15221 & S2-15222
CONTACTS PER REEL: APPROX. 4000 (PARTIAL REELS AVAILABLE)

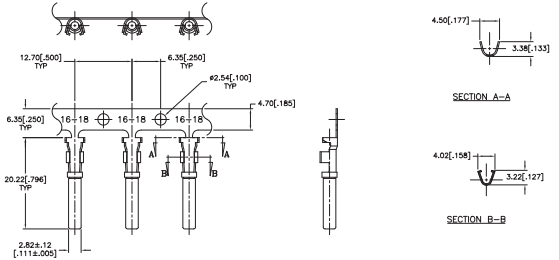

PART NUMBER: [AT62-16-06XX](#)
DESCRIPTION: CONTACT, SOCKET, STAMPED, SIZE 16

MATERIAL:
 CONTACT BODY: COPPER ALLOY
 HOOD: STAINLESS STEEL
PLATING SUFFIX CODE:
 XX=22 NICKEL PLATING
 XX=44 GOLD PLATING
CONTACT GENERAL DATA SPECIFICATION: S2-15217
AVAILABLE CRIMPERS: ATT-16-01, MFX-3950 & MFX-3953
CRIMPER SPECIFICATIONS: S2-15223 & S2-15224
CRIMP INFORMATION DRAWING: S2-15221 & S2-15222
CONTACTS PER REEL: APPROX. 4000 (PARTIAL REELS AVAILABLE)

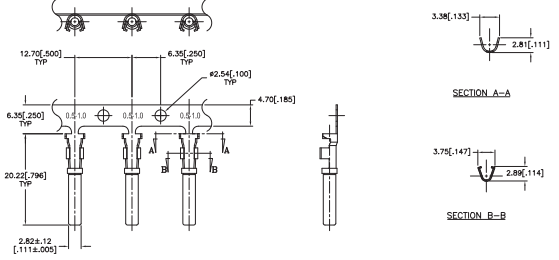

PART NUMBER: [AT60-14-01XX](#)
DESCRIPTION: CONTACT, PIN, STAMPED, SIZE 16

MATERIAL: COPPER ALLOY
PLATING SUFFIX CODE:
 XX=22 NICKEL PLATING
 XX=44 GOLD PLATING
CONTACT GENERAL DATA SPECIFICATION: S2-15217
AVAILABLE CRIMPERS: ATT-16-00, MFX-3950 & MFX-3953
CRIMPER SPECIFICATIONS: S2-15223 & S2-15224
CRIMP INFORMATION DRAWING: S2-15221 & S2-15222
CONTACTS PER REEL: APPROX. 4000 (PARTIAL REELS AVAILABLE)

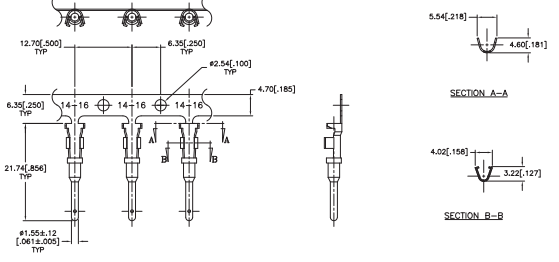

STAMPED AND FORMED CONTACTS, PG 2 of 2

Click on [blue underlined part numbers](#) to be taken to their spec sheets.

OPTIONS

PART NUMBER: [AT60-16-01XX](#)
DESCRIPTION: CONTACT, PIN, STAMPED, SIZE 16
MATERIAL: COPPER ALLOY
PLATING SUFFIX CODE:
 XX=22 NICKEL PLATING
 XX=44 GOLD PLATING
CONTACT GENERAL DATA SPECIFICATION: S2-15217
AVAILABLE CRIMPERS: ATT-16-00, ATT-16-01, MFX-3950 & MFX-3953
CRIMPER SPECIFICATIONS: S2-15223 & S2-15224
CRIMP INFORMATION DRAWING: S2-15221 & S2-15222
CONTACTS PER REEL: APPROX. 4000 (PARTIAL REELS AVAILABLE)

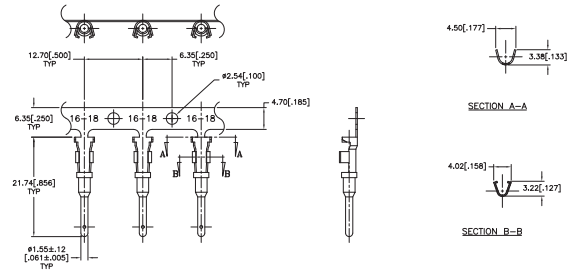

PART NUMBER: [AT60-16-06XX](#)
DESCRIPTION: CONTACT, PIN, STAMPED, SIZE 16
MATERIAL: COPPER ALLOY
PLATING SUFFIX CODE:
 XX=22 NICKEL PLATING
 XX=44 GOLD PLATING
CONTACT GENERAL DATA SPECIFICATION: S2-15217
AVAILABLE CRIMPERS: ATT-16-01, MFX-3950 & MFX-3953
CRIMPER SPECIFICATIONS: S2-15223 & S2-15224
CRIMP INFORMATION DRAWING: S2-15221 & S2-15222
CONTACTS PER REEL: APPROX. 4000 (PARTIAL REELS AVAILABLE)

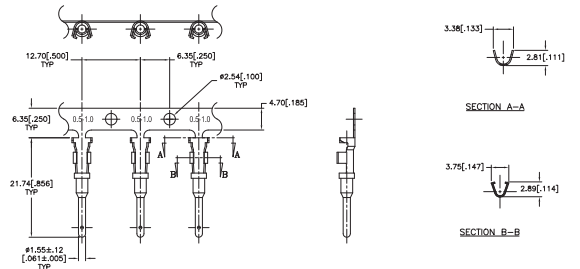

SOLID/MACHINED CONTACTS

Click on [blue underlined part numbers](#) to be taken to their spec sheets.

OPTIONS

MILITARY-STYLE

PART NUMBER: [AT60-202-16XX](#)
DESCRIPTION: CONTACT, PIN, SOLID MACHINED, SIZE 16
MATERIAL: COPPER ALLOY
PLATING SUFFIX CODE:
 XX=141 NICKEL PLATING
 XX=31 GOLD PLATING
CONTACT GENERAL DATA SPECIFICATION: S2-15217
AVAILABLE CRIMPERS: CA-5D12 & CA-5E12
CRIMPER SPECIFICATIONS: S2-15219 & S2-15220
CRIMP INFORMATION DRAWING: S2-15218

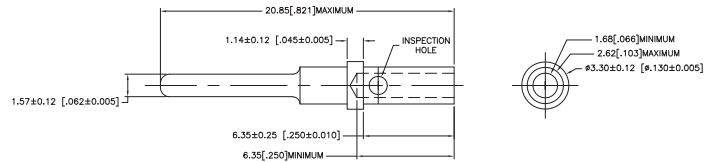

PART NUMBER: [AT62-201-16XX](#)
DESCRIPTION: CONTACT, SOCKET, SOLID MACHINED, SIZE 16
MATERIAL:
 CONTACT BODY: COPPER ALLOY
 HOOD: STAINLESS STEEL
PLATING SUFFIX CODE:
 XX=141 NICKEL PLATING
 XX=31 GOLD PLATING
CONTACT GENERAL DATA SPECIFICATION: S2-15217
AVAILABLE CRIMPERS: CA-5D12 & CA-5E12
CRIMPER SPECIFICATIONS: S2-15219 & S2-15220
CRIMP INFORMATION DRAWING: S2-15218

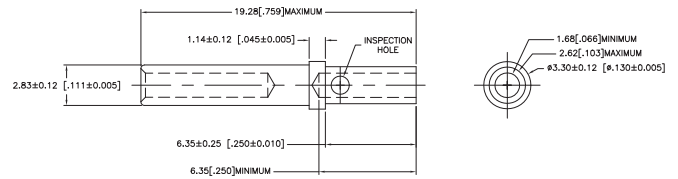

PART NUMBER: [65-54942-14](#)
DESCRIPTION: CONTACT, SOCKET, ROCKSOLID, SIZE 16
AWG RANGE: 14AWG
MATERIAL: COPPER ALLOY
PLATING: GOLD
CONTACT GENERAL DATA SPECIFICATION: S2-15217
AVAILABLE CRIMPERS: CA-5D12 & CA-5E12
CRIMPER SPECIFICATIONS: S2-15219 & S2-15220
CRIMP INFORMATION DRAWING: S2-15218

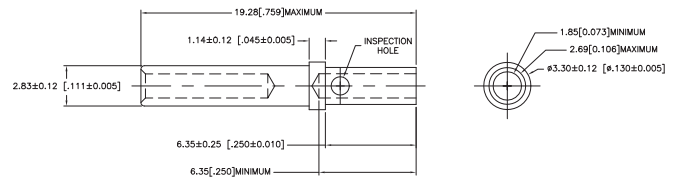

ROCKSOLID™ CONTACTS

PART NUMBER: [65-54942-16](#)
DESCRIPTION: CONTACT, SOCKET, ROCKSOLID, SIZE 16
AWG RANGE: 16AWG
MATERIAL: COPPER ALLOY
PLATING: GOLD
CONTACT GENERAL DATA SPECIFICATION: S2-15217
AVAILABLE CRIMPERS: CA-5D12 & CA-5E12
CRIMPER SPECIFICATIONS: S2-15219 & S2-15220
CRIMP INFORMATION DRAWING: S2-15218

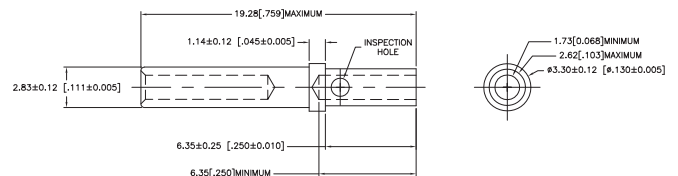

PART NUMBER: [65-54942-20](#)
DESCRIPTION: CONTACT, SOCKET, ROCKSOLID, SIZE 16
AWG RANGE: 20AWG
MATERIAL: COPPER ALLOY
PLATING: GOLD
CONTACT GENERAL DATA SPECIFICATION: S2-15217
AVAILABLE CRIMPERS: CA-5D12 & CA-5E12
CRIMPER SPECIFICATIONS: S2-15219 & S2-15220
CRIMP INFORMATION DRAWING: S2-15218

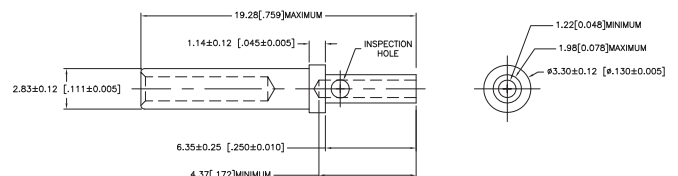

4

3

2

1

REVISONS			
REV ZONE	ECO	DESCRIPTION	DATE
A1	-	RELEASE NUMBER 016571	6/12/08
			BY B.D.B. M.R.F.

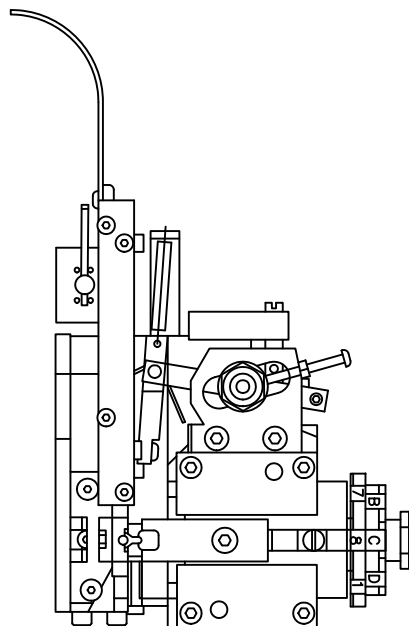
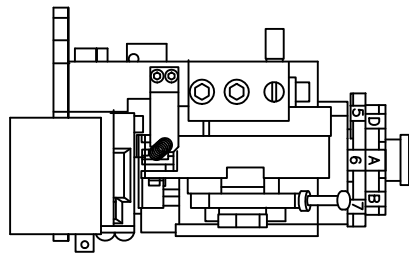

SINE PART NUMBER	MFX-3950
DEUTSCH PART NUMBER	DCT16-02-00
TYCO PART NUMBER	1-3-1385344-1, 2, 3, 4, 5 & 7

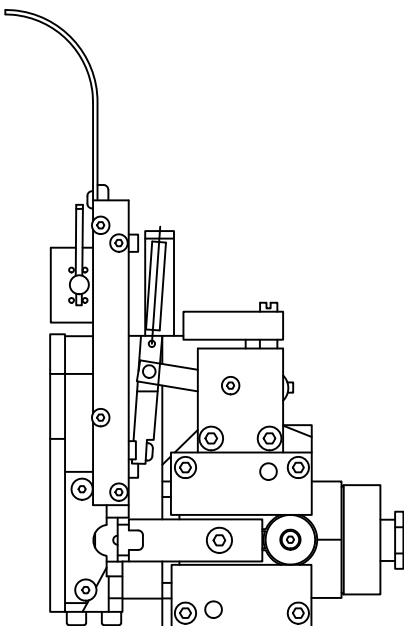
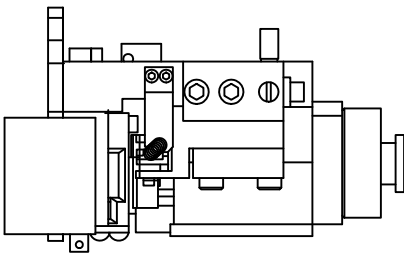

SINE PART NUMBER	MFX-3953
DEUTSCH PART NUMBER	DCT1620-02-00

ALL REFERENCES TO DEUTSCH PRODUCTS OR SPECIFICATIONS ARE FOR COMPARISON PURPOSES ONLY, AND REFER TO DEUTSCH INDUSTRIAL PRODUCTS.

ALL REFERENCES TO TYCO PRODUCTS OR SPECIFICATIONS ARE FOR COMPARISON PURPOSES ONLY, AND REFER TO TYCO ELECTRONICS.

QUANTITY	PART NUMBER	DESCRIPTION	ITEM

UNLESS OTHERWISE SPECIFIED 1) All dimensions are in inches. 2) Pl. DEC 30.00 3) Pl. DEC 30.00 4) Pl. DEC 30.00 5) Fabrication Standards Per: a) Inks SS-20020 b) Inks SS-20020 c) Inks SS-20020	SIGNATURES	DATE
	DESIGNED: BERNIM CHECKED: TONE ENGINEER: BERNIM APPROVAL: BERNIM DATE: 6/9/09	6/9/09 6/9/09 6/9/09
MATERIAL SPECIFICATIONS:	CUSTOMER:	SINE SYSTEMS CORPORATION
	PROCESS SPECIFICATIONS:	CRIMPER INFORMATION MFX-3950 & MFX-3953
MKT ASSY:		

SIZE	SCALE	REVISION
PSGA C	10X/44	A1

A

B

C

D

4

3

2

1

CRIMPER INFORMATION

22-15224

REV: A1

3

REVISIONS					
REV	ECO	DESCRIPTION	DATE	BY	APPR
A1	-	RELEASE NUMBER 016571	6/12/09	B.D.B.	M.R.F.

USE CRIMPER NUMBER:
ATT-16-00 WITH CAVITY A & B

CONTACT P/N:	INSULATION ϕ	CAVITY	WIRE SIZE
AT60-16-01**	.075 - .140	B	1.5mm ²
AT62-16-01**	[1.91 - 3.56]	A	16AWG
		A	1.0mm ²
AT60-14-01**	.095 - .150	B	14AWG
AT62-14-01**	[2.41 - 3.81]	B	2.0mm ²
		B	1.5mm ²
		A	1.5mm ²
		A	16AWG
		A	1.0mm ²
AT60-16-06**	.055 - .100	A	16AWG
AT62-16-06**	[1.40 - 2.54]	A	1.0mm ²

USE CRIMPER NUMBER:
ATT-16-01 WITH CAVITY C & D

CONTACT P/N:	INSULATION ϕ	CAVITY	WIRE SIZE
AT60-16-01**	.075 - .140	D	18AWG
AT62-16-01**	[1.91 - 3.56]	D	.75mm ²
AT60-16-06**	.055 - .100	D	18AWG
AT62-16-06**	[1.40 - 2.54]	D	.75mm ²
		C	.50mm ²

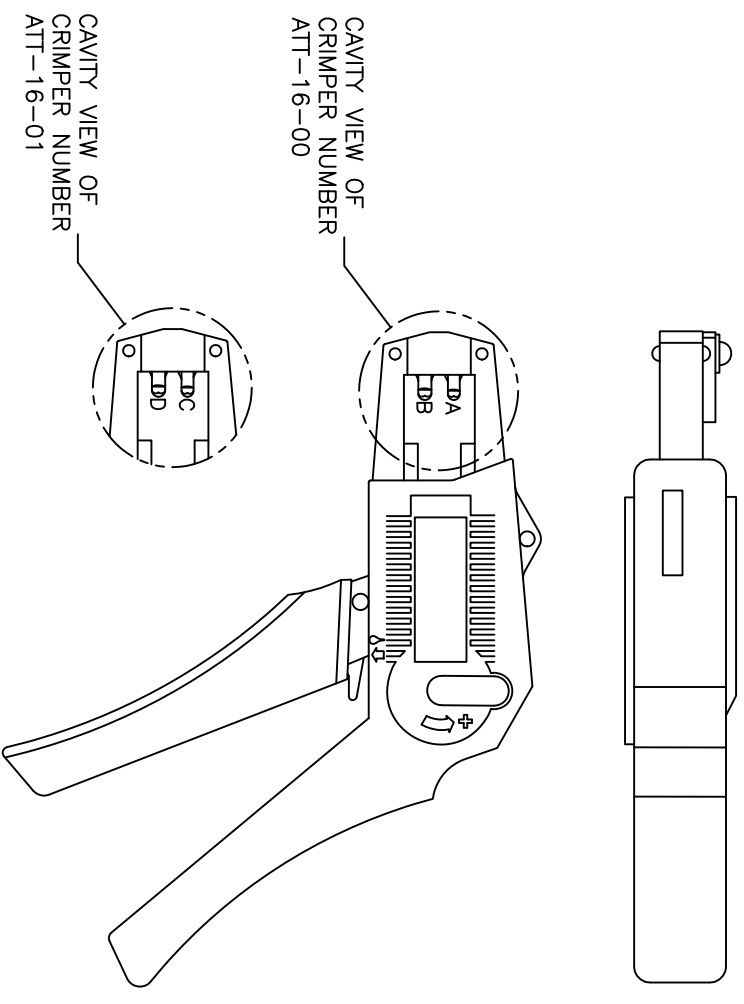

CAVITY VIEW OF
CRIMPER NUMBER
ATT-16-00

CAVITY VIEW OF
CRIMPER NUMBER
ATT-16-01

ALL REFERENCES TO DEUTSCH PRODUCTS OR SPECIFICATIONS ARE FOR COMPARISON PURPOSES ONLY, AND REFER TO DEUTSCH INDUSTRIAL PRODUCTS.

- NOTES (UNLESS OTHERWISE SPECIFIED):
- ALL DIMENSIONS IN INCHES [MILLIMETERS]
 - FOR PLATING CODES ** SEE CONTACT DATA DRAWINGS.
 - THIS TOOL IS FOR CRIMPING SIZE 16 CONTACTS ONLY TO WIRES LISTED IN THE CHARTS.
 - DEUTSCH IPD CROSS REFERENCE PART NUMBERS ARE DTT-16-00 AND DTT-16-01.

QUANTITY	PART NUMBER	DESCRIPTION	ITEM
MATERIALS LIST			
SINE Systems Corporation A Subsidiary of Amphenol Corporation 44724 Morley Drive Clinton Township, MI 48036			
INSTRUCTIONS: ATT-16-00 & 01 CRIMPER, HAND, STAMPED CONTACTS		SIZE: FSCM NO/DWG NO: B 16K44	REVISION: A1
SCALE: NONE		S2-15223	SHEET 1 OF 1

UNLESS OTHERWISE SPECIFIED	SIGNATURES	DATE
1) All dimensions are in inches.	DRAWN: BERNUW	6/8/09
2) Tolerances are as follows:	CHECKED: FORCE	6/8/09
3) 1/16 DEC .0006	ENGINEER: BERNUW	
3) 1/32 DEC .0003	APPROVAL: BERNUW	6/8/09
4) Hole Reference = A	CUSTOMER:	
MINIMUM SPECIFICATIONS:		
M/A		
PROCESS SPECIFICATIONS:		
NOT ASY:		

THE USE OF THIS DOCUMENT IS UNLIMITED. DESIGN FEATURES, SPECIFIC DATA SHOWN, METHOD AND THE PROPERTY OF AMPHENOL CORP. ALL DIMENSIONS AND TOLERANCES ARE THE PROPERTY OF AMPHENOL CORPORATION. DOCUMENTS REFERENCED HEREON MAY CONTAIN UNLIMITED VARIATIONS.
DOCUMENTS REFERENCED HEREON MAY CONTAIN UNLIMITED VARIATIONS. DEUTSCH INDUSTRIAL PRODUCTS DIV.

REV ZONE		ECO	DESCRIPTION	DATE	BY	APP
AT	-	-	RELEASE NUMBER 016871	6/12/09	B.D.B.	M.F.F.

STAMPED CONTACT PART NUMBER 106=PIN 106=SOCKET	SIZE	CONDUCTOR WIRE SIZE	CRIMP HEIGHT	CRIMP WIDTH	CONDUCTOR PUNCH NUMBER	CONDUCTOR ANVIL NUMBER	CRIMP TENSILE REFERENCE
AT80-14-011x AT82-14-011x INSULATION RANGE 0.095-0.150(2.41-3.81)	16	14 AWG 2.00mm ² 1.50mm ² 16 AWG 1.00mm ² 18 AWG 0.75mm ²	0.055(1.40) 0.055(1.40) 0.055(1.39) 0.050(1.27) 0.049(1.24) 0.048(1.22)	±0.003 INCH [±0.08 mm]	AT17-002-0200	AT17-101-0200	28(111)
AT60-16-011x AT62-16-011x INSULATION RANGE 0.075-0.140(1.91-3.56)	16	16 AWG 1.00mm ² 18 AWG 0.75mm ²	0.050(1.27) 0.051(1.30) 0.050(1.27) 0.049(1.24)	0.094(2.39) 0.094(2.39) 0.094(2.39) 0.094(2.39)	AT17-002-0200	AT17-101-0200	28(111)
AT60-16-066x INSULATION RANGE 0.055-0.100(1.40-2.54)	16	16 AWG 1.00mm ² 20 AWG 0.50mm ²	0.050(1.27) 0.049(1.24) 0.048(1.22) 0.045(1.14)	0.079(2.01) 0.079(2.01) 0.079(2.01) 0.079(2.01)	AT17-003-0200	AT17-103-0200	28(111)

CROSS REFERENCE

SINE PART NUMBER	DEUTSCH PART NUMBER
MX-3950	DC116-02-00
AT17-002-0200	1017-002-0200
AT17-003-0200	1017-003-0200
AT17-101-0200	1017-101-0200
AT17-103-0200	1017-103-0200
AT17-210-0200	1017-210-0200
AT17-211-0200	1017-211-0200
AT17-213-0200	1017-213-0200
AT17-214-0200	1017-214-0200
AT17-217-0200	1017-217-0200
AT17-218-0200	1017-218-0200
AT17-310-0200	1017-310-0200
AT17-311-0200	1017-311-0200
AT17-313-0200	1017-313-0200
AT17-304-0200	1017-304-0200
AT17-317-0200	1017-317-0200

NOTES: UNLESS OTHERWISE SPECIFIED

1. ALL DIMENSIONS ARE IN INCHES(mm).
2. FORCES ARE IN POUNDS(LBS) AND NEWTONS(N).
3. "X"= PLATING SUFFIX. SEE INDIVIDUAL CONTACT DRAWING.
4. WIRE STRIP LENGTH: 0.175±0.029(4.43±0.74). BROKEN OR MISSING CONDUCTOR STRANDS ARE NOT ACCEPTABLE.
5. USE A BLADE MICROMETER (0.100(2.54) MIN SPACING AND 0.060(0.010(1.50)(0.040) ANVIL) TO MEASURE THE CONDUCTOR CRIMP. SEE SECTION AA.
6. CRIMP TENSILE STRENGTH IS DETERMINED AT A PULL RATE SPEED OF 1.00 INCH(25.4) PER MINUTE. INSULATION WINGS ARE REMOVED FOR TEST. ACTUAL CRIMP TENSILE STRENGTH DEPENDS ON WIRE/CONDUCTOR SIZE. VALUES ON THIS SPECIFICATION ARE FOR REFERENCE ONLY.
7. INSULATION DIAMETER RANGE IS DETERMINED BY CONNECTOR AND ITS WIRE SEAL SIZE. SEE CONNECTOR DRAWING FOR INSULATION RANGE.
8. INSULATION CRIMP DIAMETER SHOULD BE THE EQUAL OR LESS THAN THE DIAMETER OF THE WIRE INSULATION (HARD OR TEFION INSULATION MAY BE AN EXCEPTION). INSULATION CRIMP SHALL NOT AFFECT REMOVAL TOOL PERFORMANCE AND SHALL NOT DAMAGE CONNECTOR GROMMET SEAL.
9. CONDUCTOR TYPE ARE PER SAE J1128(AWG) AND ISO 6722(METRIC)
10. FOR CONTACT MATERIAL AND PERFORMANCE DATA, SEE DRAWING S2-15217.
11. REFER TO S2-15223 AND S2-15224 AND CROSS REFERENCE CHARTS FOR CRIMP TOOL DATA.

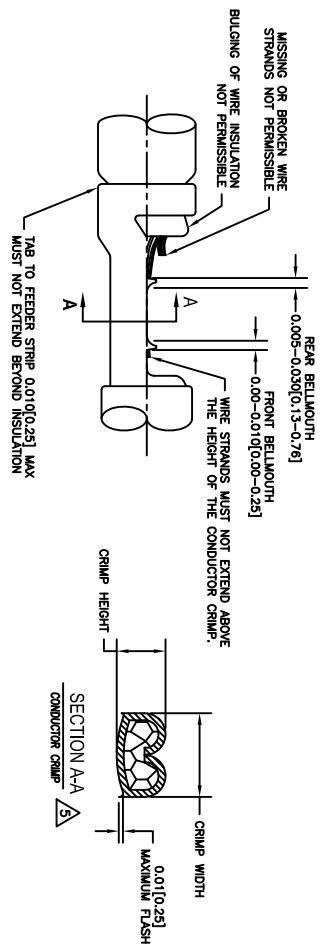
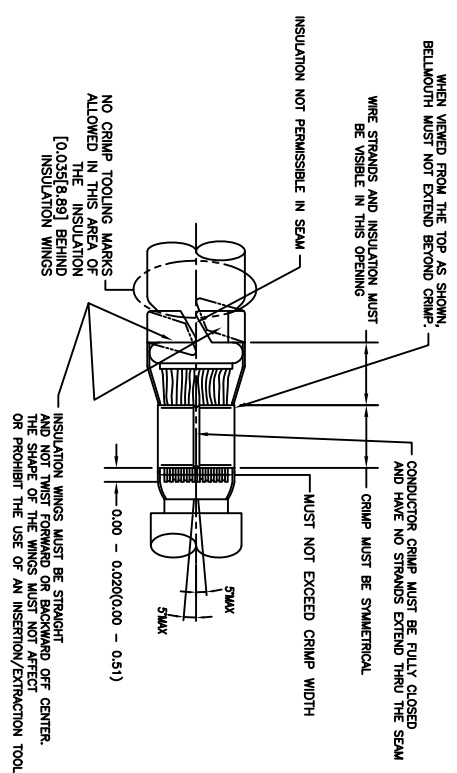

ALL REFERENCES TO DEUTSCH PRODUCTS OR SPECIFICATIONS ARE FOR COMPARISON PURPOSES ONLY, AND REFER TO DEUTSCH INDUSTRIAL PRODUCTS.

QUANTITY	PART NUMBER	MATERIALS LIST	DESCRIPTION	ITEM
UNLESS OTHERWISE SPECIFIED				
1) All dimensions are in inches.				
2) Plating is as shown.				
3) Plating is as shown.				
4) Plating is as shown.				
5) Production Standard Per:				
a) MIL-STD-20020				
b) MIL-STD-20020				
c) MIL-STD-20020				
d) MIL-STD-20020				
APPROVAL SIGNATURES				
DESIGNED BY	ROTOR	DATE	4/7/09	
CHECKED BY	ROTOR	DATE	6/8/09	
ENGINEER	BERNIM	DATE	6/8/09	
APPROVAL	BERNIM	DATE	6/8/09	
CUSTOMER: N/A				
THE USE OF THIS DRAWING IS SPECIFIC TO THE PART AND ANY CHANGES TO THE PART OR DIMENSIONS ARE SUBJECT TO REMOVAL WITHOUT NOTICE. ALL DOCUMENTS REFERENCED HEREON MAY CONTAIN UNITED STATES PATENT INFORMATION.				
CRIMP DATA, STAMPED CONTACTS FOR CRIMPER MFX-3950				
SIZE	10K44	SCALE	NONE	
REV	A1	DATE	S2-15222	SHEET 1 OF 1

A

B

C

D

4

3

2

1

REVIEWS		ECO	DESCRIPTION	DATE	BY	APP
AT	-	-	RELEASE NUMBER 016971	6/12/09	B.O.B.	M.F.F.

STAMPED CONTACT PART NUMBER (1009=PIN 1009=SOCKET)	SIZE	CONDUCTOR WIRE SIZE	CRIMP HEIGHT +0.001/-0.002 INCH (+0.025/-0.05 mm)	CRIMP WIDTH ±0.013 INCH (±0.08 mm)	CONDUCTOR PUNCH NUMBER	CONDUCTOR ANVIL NUMBER	CRIMP TENSILE REFERENCE (LBS/IN)
A160-14-017x	16	14 AWG	0.0591(1.40)	0.094(2.39)			
A162-14-017x	16	1.50mm ²	0.0591(1.40)	0.094(2.39)			
A162-14-017x INSULATION RANGE 0.075-0.140(1.91-3.56)	16	16 AWG	0.0501(1.27)	0.094(2.39)	A117-083-0200	A117-183-0200	291(11)
		1.00mm ²	0.0501(1.27)	0.094(2.39)			
		18 AWG	0.0491(1.24)	0.094(2.39)			
		0.75mm ²	0.0491(1.24)	0.094(2.39)			
		14 AWG	0.0591(1.40)	0.094(2.39)			
		2.00mm ²	0.0591(1.40)	0.094(2.39)			
		1.50mm ²	0.0591(1.40)	0.094(2.39)			
A162-16-017x	16	16 AWG	0.0501(1.27)	0.094(2.39)	A117-083-0200	A117-183-0200	291(11)
A162-16-017x INSULATION RANGE 0.075-0.140(1.91-3.56)	16	1.00mm ²	0.0501(1.27)	0.094(2.39)			
		18 AWG	0.0491(1.24)	0.094(2.39)			
		0.75mm ²	0.0491(1.24)	0.094(2.39)			
A160-16-069x	16	16 AWG	0.0501(1.27)	0.094(2.39)			
A162-16-069x	16	1.00mm ²	0.0501(1.27)	0.094(2.39)			
INSULATION RANGE 0.059-0.100(1.49-2.54)	16	20 AWG	0.0491(1.24)	0.079(2.01)	A117-082-0200	A117-182-0200	291(11)
		0.50mm ²	0.0491(1.24)	0.079(2.01)			19(67)

CROSS REFERENCE

INSULATION DIAMETER RANGE	INSULATION PUNCH NUMBER	INSULATION ANVIL NUMBER	SINE PART NUMBER	DEUTSCH PART NUMBER
0.120-0.150	[3.05-3.81]	A117-225-0200	MPX-3953	DCT1620-02-00
0.105-0.125	[2.67-3.18]	A117-226-0200	A117-083-0200	1017-083-0200
0.085-0.111	[2.16-2.82]	A117-227-0200	A117-082-0200	1017-082-0200
0.075-0.105	[1.91-2.67]	A117-228-0200	A117-183-0200	1017-183-0200
0.063-0.094	[1.62-2.39]	A117-229-0200	A117-182-0200	1017-182-0200
0.050-0.075	[1.27-1.91]	A117-230-0200	A117-225-0200	1017-225-0200
		A117-230-0200	A117-226-0200	1017-226-0200
		A117-228-0200	A117-227-0200	1017-227-0200
		A117-229-0200	A117-228-0200	1017-228-0200
		A117-230-0200	A117-229-0200	1017-229-0200
		A117-325-0200	A117-325-0200	1017-325-0200
		A117-326-0200	A117-326-0200	1017-326-0200
		A117-327-0200	A117-327-0200	1017-327-0200
		A117-328-0200	A117-328-0200	1017-328-0200
		A117-329-0200	A117-329-0200	1017-329-0200
		A117-330-0200	A117-330-0200	1017-330-0200

NOTES: UNLESS OTHERWISE SPECIFIED

1. ALL DIMENSIONS ARE IN INCHES(mm).
2. FORCES ARE IN POUNDS(LBS) AND NEWTONS(N).
3. "X"= PLATING SUFFIX. SEE INDIVIDUAL CONTACT DRAWING.
4. WIRE STRIP LENGTH: 0.175±0.029(4.43±0.54). BROKEN OR MISSING CONDUCTOR STRANDS ARE NOT ACCEPTABLE. USE A BLADE MICROMETER (0.100[2.54] MIN SPINDLE AND 0.060[0.010][1.50][0.040] ANVIL) TO MEASURE THE CONDUCTOR CRIMP. SEE SECTION AA.
5. CRIMP TENSILE STRENGTH IS DETERMINED AT A PULL RATE SPEED OF 1.00 INCH(25.4) PER MINUTE. INSULATION WINGS ARE REMOVED FOR TEST. ACTUAL CRIMP TENSILE STRENGTH DEPENDS ON WIRE/CONDUCTOR SIZE. VALUES ON THIS SPECIFICATION ARE FOR REFERENCE ONLY.
6. INSULATION DIAMETER RANGE IS DETERMINED BY CONNECTOR AND ITS WIRE SEAL SIZE. SEE CONNECTOR DRAWING FOR INSULATION RANGE.
7. INSULATION CRIMP DIAMETER SHOULD BE THE EQUAL OR LESS THAN THE DIAMETER OF THE WIRE INSULATION (HARD OR TEFLON INSULATION MAY BE AN EXCEPTION). INSULATION CRIMP SHALL NOT AFFECT REMOVAL TOOL PERFORMANCE AND SHALL NOT DAMAGE CONNECTOR GROMMET SEAL.
8. CONDUCTOR TYPE ARE PER SAE J1128(AWG) AND ISO 6122(METRIC)
9. FOR CONTACT MATERIAL AND PERFORMANCE DATA, SEE DRAWING S2-15217.
10. REFER TO S2-15223 AND S2-15224 AND CROSS REFERENCE CHARTS FOR CRIMP TOOL DATA.

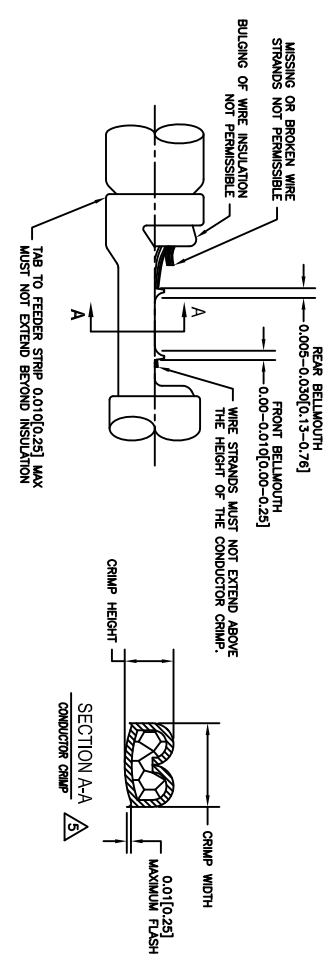
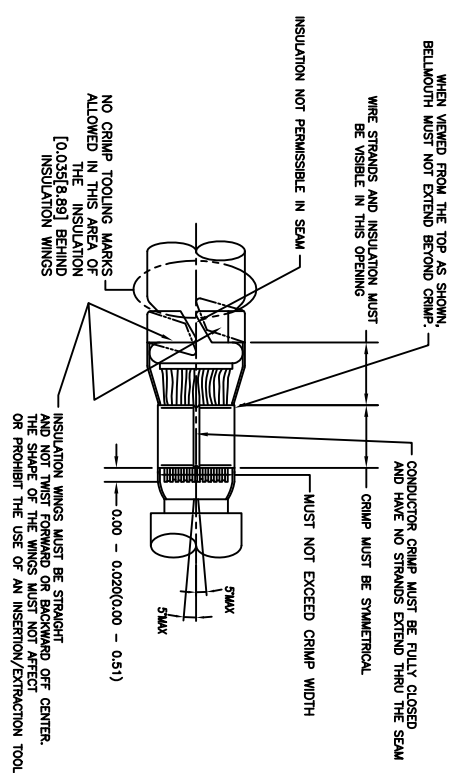

ALL REFERENCES TO DEUTSCH PRODUCTS OR SPECIFICATIONS ARE FOR COMPARISON PURPOSES ONLY, AND REFER TO DEUTSCH INDUSTRIAL PRODUCTS.

QUANTITY	PART NUMBER	MATERIALS LIST	DESCRIPTION	ITEM
			SINE Systems Corporation	
			A Subsidiary of Amphenol Corporation	
			44724 Moley Drive	
			Clinton Township, MI 48036	
			CRIMP DATA, STAMPED CONTACTS FOR CRIMPER MPX-3953	
			SIZE (P/N) 10K44	S2-15221
			SCALE NONE	S2-15221
				SHEET 1 OF 1

UNLESS OTHERWISE SPECIFIED	SIGNATURES	DATE
1) All dimensions are in inches.	DATE	4/7/09
2) All tolerances are per ASME Y14.5-2001.	DATE	6/8/09
3) Reduction Standard Per: ASME Y14.5-2001.	ENGINEER	BERNIM
4) Max. SS-20020	APPROVAL	BERNIM 6/8/09
5) Material Specification: NA	CUSTOMER	

REVOLUTIONS		DESCRIPTION	DATE	BY	APPR
REV	ZONE	ECO	RELEASE NUMBER 016571	6/12/09	B.D.B.
A1	-	-			M.R.F.

CONTACT LOCATOR "TURRET"
THREE POSITION FOR SIZE
12, 16 & 20 MALE AND
FEMALE CONTACTS

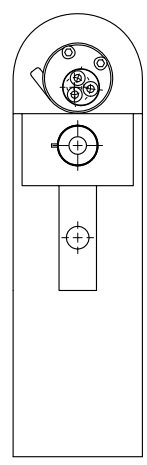

"TURRET"
RELEASE LATCH

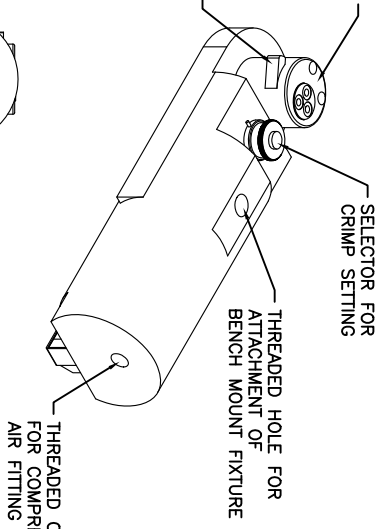

SELECTOR FOR
CRIMP SETTING

THREADED HOLE FOR
ATTACHMENT OF
BENCH MOUNT FIXTURE

THREADED OPENING
FOR COMPRESSED
AIR FITTING

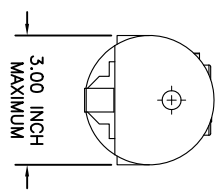
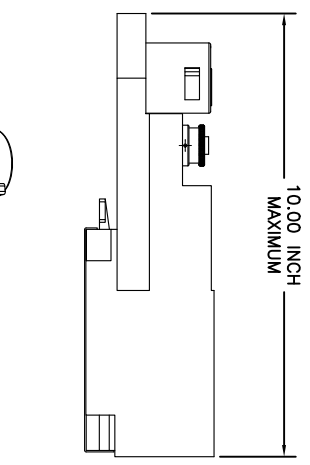

- NOTES:
1. THE CA-5E12 IS A COMPRESSED AIR OPERATED HAND CRIMPER FOR ELECTRICAL CONTACTS. IT IS ADJUSTABLE TO 3 CONTACT SIZES (12, 16 & 20) AND 8 INDENTER CRIMP POSITIONS FOR DIFFERENT WIRE SIZES (12AWG THRU 26 AWG).
 2. 80-120 PSI COMPRESSED AIR.
 3. WEIGHT: 3.1 LBS
 4. SELECTING CONTACT SIZE: PRESS THE RELEASE LATCH ON SIDE OF THE CONTACT LOCATOR "TURRET". ROTATE TO THE DESIRED CONTACT SIZE. THE TOP OF THE "TURRET" IS EMBOSSED WITH THE CONTACT SIZES.
 5. SELECTING WIRE SIZE: GRASP THE SELECTOR AND ROTATE TO THE DESIRED NUMBER.

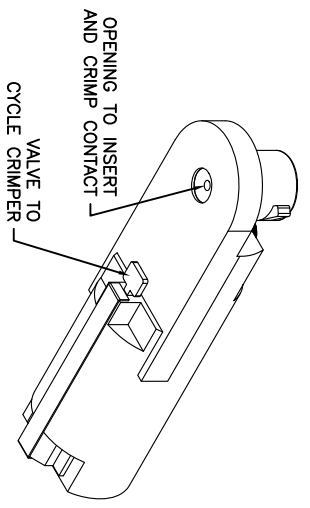

GAGE PART NO.	A GO DIA.	B NO-GO DIA.	SELECTOR NUMBER
G125	.0390	.0440	4

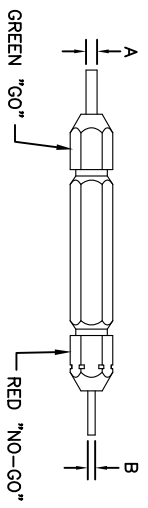

GAGING INSTRUCTIONS

CAUTION!
DO NOT CRIMP GAGE!

"GO" GAGING: OPERATE TOOL TO FULLY CLOSED POSITION. INSERT "GO" GAGE END AS SHOWN. GAGE MUST PASS FREELY BETWEEN INDENTER TIPS.

"NO-GO" GAGING: OPERATE TOOL TO FULLY CLOSED POSITION. INSERT "NO-GO" GAGE END AS SHOWN. THE "NO-GO" MAY PARTIALLY ENTER THE INDENTER OPENING, BUT MUST NOT PASS COMPLETELY THROUGH THE OPENING.

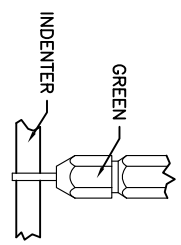

SELECTOR NUMBER	A GO DIA.	B NO-GO DIA.
1	.0280	.0330
2	.0320	.0370
3	.0360	.0410
4	.0390	.0440
5	.0450	.0500
6	.0520	.0570
7	.0590	.0640
8	.0680	.0730

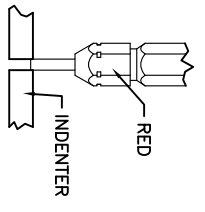

CONTACT SIZE	LOCATOR "TURRET" POSITION COLOR	26 AWG WIRE	24 AWG WIRE	22 AWG WIRE	20 AWG WIRE	18 AWG WIRE	16 AWG WIRE	14 AWG WIRE	12 AWG WIRE
20-20	RED	1	2	3	4				
16-22	BLUE	4	5	6					
16-20	BLUE	1	2	3	4				
16-16	BLUE				4	5	6		
12-16	YELLOW				4	5	6		
12-12	YELLOW							7	8

QUANTITY	PART NUMBER	DESCRIPTION	ITEM
		MATERIALS LIST	

UNLESS OTHERWISE SPECIFIED

1) All dimensions are in inches.

2) Pl. DEC 2000 1 Position 31/14

3) Pl. DEC 2001 1 Position 31/14

4) Revision Standard Per: APPROVAL: U

5) Rev. SS-20020

DATE: 6/3/09

DESIGNED BY: BERNU

CHECKED BY: BERNU

APPROVED BY: BERNU

DATE: 6/3/09

THE USE OF THIS DRAWING IS SPECIFIC TO THE PART AND SPECIFICATIONS AND PERFORMANCE INDICATED THEREON. ANY REVISIONS OR ALTERATIONS TO THIS DRAWING MUST BE APPROVED BY THE ORIGINAL DESIGNER AND THE CUSTOMER. ALL DIMENSIONS REFERENCED HEREON ARE DRAWING DIMENSIONS UNLESS OTHERWISE SPECIFIED.

INSTRUCTIONS FOR CA-5E12 CRIMPER, PNEUMATIC

SIZE: 10K44

SCALE: NONE

S2-15220

SHEET 1 OF 1

REVISION A1

REV ZONE		ECO		REVISIONS		DESCRIPTION	DATE	BY	APPR
AI	-	-	-	RELEASE NUMBER	016571		6/12/09	B.D.B.	M.R.F.

CONTACT LOCATOR
"TURRET"
THREE POSITIONS FOR
SIZE 12, 16 & 20 MALE
AND FEMALE CONTACTS

"TURRET" RELEASE LATCH

6.25 INCH
MAXIMUM
OPEN

2.30 INCH
MAXIMUM
CLOSED

SELECTOR FOR CRIMP
SETTING

1.125 INCH MAX.

9.75 INCH MAXIMUM

1.00 INCH MAX.

- NOTES:
- THE CA-5D12 IS A HAND OPERATED CRIMPER FOR ELECTRICAL CONTACTS. IT IS ADJUSTABLE TO 3 CONTACT SIZES (12, 16 & 20) AND 8 INDENTER CRIMP POSITIONS FOR DIFFERENT WIRE SIZES (12AWG THRU 26 AWG).
 - WEIGHT: 1.64 LBS
 - SELECTING CONTACT SIZE: PRESS THE RELEASE LATCH ON SIDE OF THE CONTACT LOCATOR "TURRET". ROTATE TO THE DESIRED CONTACT SIZE. THE TOP OF THE "TURRET" IS EMBOSSED WITH THE CONTACT SIZES.
 - SELECTING WIRE SIZE: REMOVE THE LOCKING CLIP. GRASP THE SELECTOR AND ROTATE TO THE DESIRED NUMBER.

GAGE PART NO.	A GO DIA.	B NO-GO DIA.	SELECTOR NUMBER
G125	.0390	.0440	4

GAGING INSTRUCTIONS

CAUTION!
DO NOT CRIMP GAGE!

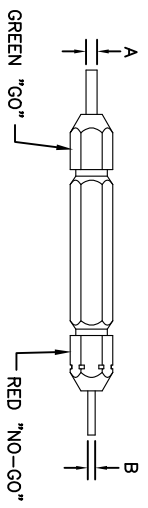

"GO" GAGING: OPERATE TOOL TO FULLY CLOSED POSITION. INSERT "GO" GAGE END AS SHOWN. GAGE MUST PASS FREELY BETWEEN INDENTER TIPS.

"NO-GO" GAGING: OPERATE TOOL TO FULLY CLOSED POSITION. INSERT "NO-GO" GAGE END AS SHOWN. THE "NO-GO" MAY PARTIALLY ENTER THE INDENTER OPENING, BUT MUST NOT PASS COMPLETELY THROUGH THE OPENING.

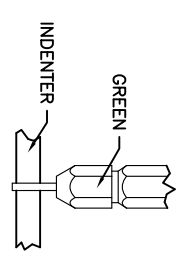

SELECTOR NUMBER	A GO DIA.	B NO-GO DIA.
1	.0280	.0330
2	.0320	.0370
3	.0360	.0410
4	.0390	.0440
5	.0450	.0500
6	.0520	.0570
7	.0590	.0640
8	.0880	.0730

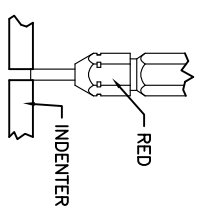

CONTACT SIZE	LOCATOR "TURRET" POSITION	WIRE COLOR	1	2	3	4	5	6	7	8
20-20	RED	1	2	3	4					
16-22	BLUE	4	5	6						
16-20	BLUE	1	2	3	4					
16-16	BLUE	4	5	6						
12-16	YELLOW	4	5	6						
12-12	YELLOW									8

QUANTITY PART NUMBER MATERIALS LIST DESCRIPTION ITEM

UNLESS OTHERWISE SPECIFIED:
1) All dimensions are in inches.
2) Finish: .0005
3) Pl. Sec. 40.00
4) Pl. Sec. 40.00
5) Pl. Sec. 40.00
6) Pl. Sec. 40.00
7) Pl. Sec. 40.00
8) Pl. Sec. 40.00
9) Pl. Sec. 40.00
10) Pl. Sec. 40.00
11) Pl. Sec. 40.00
12) Pl. Sec. 40.00
13) Pl. Sec. 40.00
14) Pl. Sec. 40.00
15) Pl. Sec. 40.00
16) Pl. Sec. 40.00
17) Pl. Sec. 40.00
18) Pl. Sec. 40.00
19) Pl. Sec. 40.00
20) Pl. Sec. 40.00
21) Pl. Sec. 40.00
22) Pl. Sec. 40.00
23) Pl. Sec. 40.00
24) Pl. Sec. 40.00
25) Pl. Sec. 40.00
26) Pl. Sec. 40.00
27) Pl. Sec. 40.00
28) Pl. Sec. 40.00
29) Pl. Sec. 40.00
30) Pl. Sec. 40.00
31) Pl. Sec. 40.00
32) Pl. Sec. 40.00
33) Pl. Sec. 40.00
34) Pl. Sec. 40.00
35) Pl. Sec. 40.00
36) Pl. Sec. 40.00
37) Pl. Sec. 40.00
38) Pl. Sec. 40.00
39) Pl. Sec. 40.00
40) Pl. Sec. 40.00
41) Pl. Sec. 40.00
42) Pl. Sec. 40.00
43) Pl. Sec. 40.00
44) Pl. Sec. 40.00
45) Pl. Sec. 40.00
46) Pl. Sec. 40.00
47) Pl. Sec. 40.00
48) Pl. Sec. 40.00
49) Pl. Sec. 40.00
50) Pl. Sec. 40.00
51) Pl. Sec. 40.00
52) Pl. Sec. 40.00
53) Pl. Sec. 40.00
54) Pl. Sec. 40.00
55) Pl. Sec. 40.00
56) Pl. Sec. 40.00
57) Pl. Sec. 40.00
58) Pl. Sec. 40.00
59) Pl. Sec. 40.00
60) Pl. Sec. 40.00
61) Pl. Sec. 40.00
62) Pl. Sec. 40.00
63) Pl. Sec. 40.00
64) Pl. Sec. 40.00
65) Pl. Sec. 40.00
66) Pl. Sec. 40.00
67) Pl. Sec. 40.00
68) Pl. Sec. 40.00
69) Pl. Sec. 40.00
70) Pl. Sec. 40.00
71) Pl. Sec. 40.00
72) Pl. Sec. 40.00
73) Pl. Sec. 40.00
74) Pl. Sec. 40.00
75) Pl. Sec. 40.00
76) Pl. Sec. 40.00
77) Pl. Sec. 40.00
78) Pl. Sec. 40.00
79) Pl. Sec. 40.00
80) Pl. Sec. 40.00
81) Pl. Sec. 40.00
82) Pl. Sec. 40.00
83) Pl. Sec. 40.00
84) Pl. Sec. 40.00
85) Pl. Sec. 40.00
86) Pl. Sec. 40.00
87) Pl. Sec. 40.00
88) Pl. Sec. 40.00
89) Pl. Sec. 40.00
90) Pl. Sec. 40.00
91) Pl. Sec. 40.00
92) Pl. Sec. 40.00
93) Pl. Sec. 40.00
94) Pl. Sec. 40.00
95) Pl. Sec. 40.00
96) Pl. Sec. 40.00
97) Pl. Sec. 40.00
98) Pl. Sec. 40.00
99) Pl. Sec. 40.00
100) Pl. Sec. 40.00

SINE Systems Corporation
A Subsidiary of Amphenol Corporation
44724 Moley Drive
Canton Township, MI 48036

INSTRUCTIONS FOR CA-5D12
CRIMPER, HAND, MACHINED CONTACTS

SIZE: 10K44
SCALE: NONE
S2-15219
SHEET: 1 OF 1

REVOLUTIONS		DESCRIPTION	DATE	BY	APPR
REV	ZONE	ECO	RELEASE NUMBER 016571	B.D.B.	M.R.F.
A1	-	-			

CONTACT P/N	SIZE TYPE	WIRE SIZE	REF. ONLY TENSILE LBS[N]
AT60-202-16XX	16PIN	1.5mm ² 16AWG	35[156]
AT62-201-16XX	16SOC	1.0mm ² 18AWG 0.75mm ² 20AWG	25[111]
		0.50mm ²	20[89]

RECOMMENDED STRIP LENGTH	
CONTACT SIZE	STRIP LENGTH INCH[MM]
16	0.250-0.312[6.35-7.92]

CRIMP TOOLING						
CONTACT SIZE	CRIMP TOOL PART NUMBER	CONTACT LOCATOR "TURRET" POSITION	WIRE SELECTOR NUMBER	GO GAGE INCH[MM]	"NOGO" GAGE INCH[MM]	REMARKS
16	CA-5D12 CA-5E12	BLUE	6	0.052[1.32]	0.057[1.45]	
16	CA-5D12 CA-5E12	BLUE	4	0.039[.991]	0.044[1.12]	SIZE 16 WITH 20 AWG WIRE

- NOTES: UNLESS OTHERWISE SPECIFIED
- 1. MINIMUM +/-0.0005 [0.013] TOLERANCE STEEL GAGE PINS. DO NOT CRIMP GAGE PINS. CLOSE DIE, THEN USE GAGE PINS.
 - 2. WHEN XX=31, CONTACT PLATING IS GOLD WHEN XX=141, CONTACT PLATING IS NICKEL
 - 3. PULL RATE OF 1.0 IN [25.4] PER MINUTE. ACTUAL STRENGTH DEPENDS ON WIRE SIZE.
 - 4. FOR CONTACT PERFORMANCE, MATERIAL SPECIFICATIONS AND APPLICATION DETAILS, SEE DRAWING S2-15217.
 - 5. CONDUCTOR STRANDS MUST BE VISIBLE THRU THE INSPECTION HOLE PRIOR TO CRIMP.
 - 6. PROPER CRIMP TOOLING WILL PRODUCE A CRIMP CENTERED BETWEEN THE INSPECTION HOLE AND CRIMP BARREL END.
 - 7. WIRE SIZES PER SAE J1128 AND J1560 [DIN 72551-6] REFERENCE INSTRUCTION MANUALS S2-15219 AND S2-15220 FOR CA-5D12 AND CA-5E12 HAND AND PNEUMATIC CRIMPER.
 - 8. THE CRIMP HEIGHT DIMENSION AFTER CRIMPING MAY VARY FROM THE VALUES LISTED FOR THE "GO-NOGO" PINS.

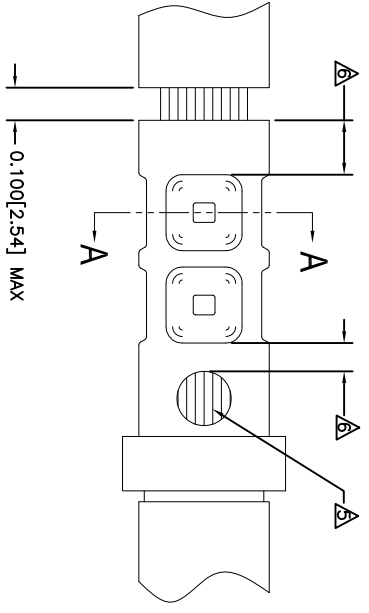
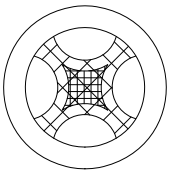

SECTION A-A
CRIMP CROSS-SECTION

QUANTITY	PART NUMBER	DESCRIPTION	ITEM
	MATERIALS LIST		
	SIGNATURES	DATE	
	DESIGNER: BERNUIM	6/3/09	
	CHECKER: RONE	6/3/09	
	ENGINEER: BERNUIM		
	APPROVAL: BERNUIM	6/3/09	
	CUSTOMER: M/A		
	SINE SYSTEMS CORPORATION A Subsidiary of Amphenol Corporation 44724 Moley Drive Clinton Township, MI 48036		
	CRIMP INFORMATION SOLID MACHINED CONTACTS		
	SIZE [P/N] (MATERIAL)	SCALE	REVISION
	C [10K44]	S2-15218	A1
		SHEET 1 OF 1	

UNLESS OTHERWISE SPECIFIED
1) All dimensions are in inches.
2) See drawing for tolerances.
3) Pl. SEE 40.00 [1.016] Precision 31/64
4) Pl. SEE 40.01 [1.016] Precision 31/64
5) Fabrication Standards Per: A
6) Pl. SEE 40.02 [1.016] Precision 31/64
7) Pl. SEE 40.03 [1.016] Precision 31/64
8) Pl. SEE 40.04 [1.016] Precision 31/64
9) Pl. SEE 40.05 [1.016] Precision 31/64
10) Pl. SEE 40.06 [1.016] Precision 31/64
11) Pl. SEE 40.07 [1.016] Precision 31/64
12) Pl. SEE 40.08 [1.016] Precision 31/64
13) Pl. SEE 40.09 [1.016] Precision 31/64
14) Pl. SEE 40.10 [1.016] Precision 31/64
15) Pl. SEE 40.11 [1.016] Precision 31/64
16) Pl. SEE 40.12 [1.016] Precision 31/64
17) Pl. SEE 40.13 [1.016] Precision 31/64
18) Pl. SEE 40.14 [1.016] Precision 31/64
19) Pl. SEE 40.15 [1.016] Precision 31/64
20) Pl. SEE 40.16 [1.016] Precision 31/64
21) Pl. SEE 40.17 [1.016] Precision 31/64
22) Pl. SEE 40.18 [1.016] Precision 31/64
23) Pl. SEE 40.19 [1.016] Precision 31/64
24) Pl. SEE 40.20 [1.016] Precision 31/64
25) Pl. SEE 40.21 [1.016] Precision 31/64
26) Pl. SEE 40.22 [1.016] Precision 31/64
27) Pl. SEE 40.23 [1.016] Precision 31/64
28) Pl. SEE 40.24 [1.016] Precision 31/64
29) Pl. SEE 40.25 [1.016] Precision 31/64
30) Pl. SEE 40.26 [1.016] Precision 31/64
31) Pl. SEE 40.27 [1.016] Precision 31/64
32) Pl. SEE 40.28 [1.016] Precision 31/64
33) Pl. SEE 40.29 [1.016] Precision 31/64
34) Pl. SEE 40.30 [1.016] Precision 31/64
35) Pl. SEE 40.31 [1.016] Precision 31/64
36) Pl. SEE 40.32 [1.016] Precision 31/64
37) Pl. SEE 40.33 [1.016] Precision 31/64
38) Pl. SEE 40.34 [1.016] Precision 31/64
39) Pl. SEE 40.35 [1.016] Precision 31/64
40) Pl. SEE 40.36 [1.016] Precision 31/64
41) Pl. SEE 40.37 [1.016] Precision 31/64
42) Pl. SEE 40.38 [1.016] Precision 31/64
43) Pl. SEE 40.39 [1.016] Precision 31/64
44) Pl. SEE 40.40 [1.016] Precision 31/64
45) Pl. SEE 40.41 [1.016] Precision 31/64
46) Pl. SEE 40.42 [1.016] Precision 31/64
47) Pl. SEE 40.43 [1.016] Precision 31/64
48) Pl. SEE 40.44 [1.016] Precision 31/64
49) Pl. SEE 40.45 [1.016] Precision 31/64
50) Pl. SEE 40.46 [1.016] Precision 31/64
51) Pl. SEE 40.47 [1.016] Precision 31/64
52) Pl. SEE 40.48 [1.016] Precision 31/64
53) Pl. SEE 40.49 [1.016] Precision 31/64
54) Pl. SEE 40.50 [1.016] Precision 31/64
55) Pl. SEE 40.51 [1.016] Precision 31/64
56) Pl. SEE 40.52 [1.016] Precision 31/64
57) Pl. SEE 40.53 [1.016] Precision 31/64
58) Pl. SEE 40.54 [1.016] Precision 31/64
59) Pl. SEE 40.55 [1.016] Precision 31/64
60) Pl. SEE 40.56 [1.016] Precision 31/64
61) Pl. SEE 40.57 [1.016] Precision 31/64
62) Pl. SEE 40.58 [1.016] Precision 31/64
63) Pl. SEE 40.59 [1.016] Precision 31/64
64) Pl. SEE 40.60 [1.016] Precision 31/64
65) Pl. SEE 40.61 [1.016] Precision 31/64
66) Pl. SEE 40.62 [1.016] Precision 31/64
67) Pl. SEE 40.63 [1.016] Precision 31/64
68) Pl. SEE 40.64 [1.016] Precision 31/64
69) Pl. SEE 40.65 [1.016] Precision 31/64
70) Pl. SEE 40.66 [1.016] Precision 31/64
71) Pl. SEE 40.67 [1.016] Precision 31/64
72) Pl. SEE 40.68 [1.016] Precision 31/64
73) Pl. SEE 40.69 [1.016] Precision 31/64
74) Pl. SEE 40.70 [1.016] Precision 31/64
75) Pl. SEE 40.71 [1.016] Precision 31/64
76) Pl. SEE 40.72 [1.016] Precision 31/64
77) Pl. SEE 40.73 [1.016] Precision 31/64
78) Pl. SEE 40.74 [1.016] Precision 31/64
79) Pl. SEE 40.75 [1.016] Precision 31/64
80) Pl. SEE 40.76 [1.016] Precision 31/64
81) Pl. SEE 40.77 [1.016] Precision 31/64
82) Pl. SEE 40.78 [1.016] Precision 31/64
83) Pl. SEE 40.79 [1.016] Precision 31/64
84) Pl. SEE 40.80 [1.016] Precision 31/64
85) Pl. SEE 40.81 [1.016] Precision 31/64
86) Pl. SEE 40.82 [1.016] Precision 31/64
87) Pl. SEE 40.83 [1.016] Precision 31/64
88) Pl. SEE 40.84 [1.016] Precision 31/64
89) Pl. SEE 40.85 [1.016] Precision 31/64
90) Pl. SEE 40.86 [1.016] Precision 31/64
91) Pl. SEE 40.87 [1.016] Precision 31/64
92) Pl. SEE 40.88 [1.016] Precision 31/64
93) Pl. SEE 40.89 [1.016] Precision 31/64
94) Pl. SEE 40.90 [1.016] Precision 31/64
95) Pl. SEE 40.91 [1.016] Precision 31/64
96) Pl. SEE 40.92 [1.016] Precision 31/64
97) Pl. SEE 40.93 [1.016] Precision 31/64
98) Pl. SEE 40.94 [1.016] Precision 31/64
99) Pl. SEE 40.95 [1.016] Precision 31/64
100) Pl. SEE 40.96 [1.016] Precision 31/64
101) Pl. SEE 40.97 [1.016] Precision 31/64
102) Pl. SEE 40.98 [1.016] Precision 31/64
103) Pl. SEE 40.99 [1.016] Precision 31/64
104) Pl. SEE 40.100 [1.016] Precision 31/64

REVOLUTIONS		DESCRIPTION	DATE	BY	APPR
REV	ZONE	ECO	6/12/08	B.D.B.	M.R.F.
AT	-	-	RELEASE NUMBER 016871		

SOLID CONTACT SIZE	SOLID CONTACT PART NUMBERS		WIRE SIZE AVG (mm ²)	RECOMMENDED STRIP LENGTH INCH (mm)	MIN CONTACT RETENTION LBS (N)	REF CRIMP TENSILE LBS (N)	MAX RATED AMPS @ 125°C CONTINUOUS
	PN	SOCKET					
16	AT60-202-16**	AT62-201-16**	16-20 [1.5-0.5]	0.25-0.31 [6.35-7.92]	25 [1111]	35-20 [156-89]	13

S&P CONTACT SIZE	STAMPED CONTACT PART NUMBERS		WIRE SIZE AVG (mm ²)	WIRE INSULATION O.D. RANGE	RECOMMENDED STRIP LENGTH INCH (mm)	MIN CONTACT RETENTION LBS (N)	REF CRIMP TENSILE LBS (N)	MAX RATED AMPS @ 125°C CONTINUOUS
	PN	SOCKET						
16	AT60-14-01**	AT62-14-01**	14-16 [2.0-1.0]	.100 - .150 [2.54 - 3.81]	0.150-0.200 [3.81-5.08]	25 [1111]	25 [1111]	13
16	AT60-16-01**	AT62-16-01**	16-18 [1.0-0.75]	.075 - .100 [1.90 - 2.54]	0.150-0.200 [3.81-5.08]	25 [1111]	25 [1111]	13
16	AT60-16-06**	AT62-16-06**	18-20 [0.75-0.50]	.055 - .095 [1.40 - 2.41]	0.150-0.200 [3.81-5.08]	25 [1111]	25-15 [111+67]	13

CONTACT RESISTANCE STRENGTH (LESS DROP THROUGH WIRE)			
WIRE AWG	TEST CURRENT	MILLIVOLT DROP SOLID	MILLIVOLT DROP S&P
14	18	60	100
16	13	60	100
18	10	60	100
20	7.5	60	100

MATERIAL SPECIFICATION AND PLATING ** CODES	
PN: COPPER ALLOY	
SOCKET: COPPER ALLOY WITH STAINLESS STEEL SLEEVE	
SOLID MACHINED CONTACT PLATING OPTIONS: Δ	31= GOLD* 141= NICKEL
STAMPED CONTACT PLATING OPTIONS: Δ	22= NICKEL 44= GOLD* 89= SELECTIVE GOLD*
GOLD* PLATING IS AVAILABLE (RECOMMENDED) FOR ONLY (<5V) CIRCUIT APPLICATIONS	
MATERIALS AND PLATINGS ARE ROHS COMPLIANT	

NOTES: UNLESS OTHERWISE SPECIFIED

1. ALL DIMENSIONS ARE INCHES(MM).
 2. ALL FORCES ARE IN LBS(POUNDS) AND "N" (NEWTONS).
 - Δ CONTACT RETENTION TEST PULL RATE SHALL BE 1.0 INCH/2S. 4) PER MINUTE MAXIMUM. WIRE SIZE WILL AFFECT THE TRUE STRENGTH OF THE CRIMP.
 - Δ WIRE SIZES AND INSULATION RANGES ARE FOR REFERENCE ONLY. THE ACTUAL INSULATION RANGE DEPENDS ON CONNECTOR GROMMET SEALING SIZE.
- SEE SPECIFICATIONS LISTED BELOW FOR INDIVIDUAL CRIMP INFORMATION:
- | | | | |
|------------------|----------|--------------------|----------|
| *SOLID* CONTACTS | SIZE | *STAMPED* CONTACTS | SIZE |
| | S2-15218 | | S2-15222 |
| | 16 | | 16 |
| | | | S2-15221 |
| | | | 16/20 |
- MAXIMUM RATED CURRENT IN CHART DEPENDS ON CONTACT SIZE. ACTUAL RATED CURRENT DEPENDS ON WIRE SIZE.
 Δ CONTACT FACTORY FOR ALL AVAILABLE PLATING ON SPECIFIC CONTACTS.
 Δ AMPHENOL SINE PERFORMANCE SPECIFICATIONS REQUIRE THE USE OF AMPHENOL SINE APPROVED TOOLING.

PART NUMBER		DESCRIPTION		ITEM
QUANTITY		MATERIALS LIST		
UNLESS OTHERWISE SPECIFIED		SIGNATURES		DATE
1) All dimensions are in inches.		DATE:	4/5/09	
2) All tolerances are as shown.		ORDERED:	6/3/09	
3) Pl. DEC 20.00		ENGINEER:	BERNIM	
4) Pl. DEC 20.00		APPROVAL:	BERNIM	6/3/09
5) Fabrication Standards Per:		CUSTOMER:		
6) Pl. DEC 20.00		APPROVAL:		
7) Pl. DEC 20.00		CUSTOMER:		
8) Pl. DEC 20.00		APPROVAL:		
9) Pl. DEC 20.00		CUSTOMER:		
10) Pl. DEC 20.00		APPROVAL:		
11) Pl. DEC 20.00		CUSTOMER:		
12) Pl. DEC 20.00		APPROVAL:		
13) Pl. DEC 20.00		CUSTOMER:		
14) Pl. DEC 20.00		APPROVAL:		
15) Pl. DEC 20.00		CUSTOMER:		
16) Pl. DEC 20.00		APPROVAL:		
17) Pl. DEC 20.00		CUSTOMER:		
18) Pl. DEC 20.00		APPROVAL:		
19) Pl. DEC 20.00		CUSTOMER:		
20) Pl. DEC 20.00		APPROVAL:		
21) Pl. DEC 20.00		CUSTOMER:		
22) Pl. DEC 20.00		APPROVAL:		
23) Pl. DEC 20.00		CUSTOMER:		
24) Pl. DEC 20.00		APPROVAL:		
25) Pl. DEC 20.00		CUSTOMER:		
26) Pl. DEC 20.00		APPROVAL:		
27) Pl. DEC 20.00		CUSTOMER:		
28) Pl. DEC 20.00		APPROVAL:		
29) Pl. DEC 20.00		CUSTOMER:		
30) Pl. DEC 20.00		APPROVAL:		
31) Pl. DEC 20.00		CUSTOMER:		
32) Pl. DEC 20.00		APPROVAL:		
33) Pl. DEC 20.00		CUSTOMER:		
34) Pl. DEC 20.00		APPROVAL:		
35) Pl. DEC 20.00		CUSTOMER:		
36) Pl. DEC 20.00		APPROVAL:		
37) Pl. DEC 20.00		CUSTOMER:		
38) Pl. DEC 20.00		APPROVAL:		
39) Pl. DEC 20.00		CUSTOMER:		
40) Pl. DEC 20.00		APPROVAL:		
41) Pl. DEC 20.00		CUSTOMER:		
42) Pl. DEC 20.00		APPROVAL:		
43) Pl. DEC 20.00		CUSTOMER:		
44) Pl. DEC 20.00		APPROVAL:		
45) Pl. DEC 20.00		CUSTOMER:		
46) Pl. DEC 20.00		APPROVAL:		
47) Pl. DEC 20.00		CUSTOMER:		
48) Pl. DEC 20.00		APPROVAL:		
49) Pl. DEC 20.00		CUSTOMER:		
50) Pl. DEC 20.00		APPROVAL:		
51) Pl. DEC 20.00		CUSTOMER:		
52) Pl. DEC 20.00		APPROVAL:		
53) Pl. DEC 20.00		CUSTOMER:		
54) Pl. DEC 20.00		APPROVAL:		
55) Pl. DEC 20.00		CUSTOMER:		
56) Pl. DEC 20.00		APPROVAL:		
57) Pl. DEC 20.00		CUSTOMER:		
58) Pl. DEC 20.00		APPROVAL:		
59) Pl. DEC 20.00		CUSTOMER:		
60) Pl. DEC 20.00		APPROVAL:		
61) Pl. DEC 20.00		CUSTOMER:		
62) Pl. DEC 20.00		APPROVAL:		
63) Pl. DEC 20.00		CUSTOMER:		
64) Pl. DEC 20.00		APPROVAL:		
65) Pl. DEC 20.00		CUSTOMER:		
66) Pl. DEC 20.00		APPROVAL:		
67) Pl. DEC 20.00		CUSTOMER:		
68) Pl. DEC 20.00		APPROVAL:		
69) Pl. DEC 20.00		CUSTOMER:		
70) Pl. DEC 20.00		APPROVAL:		
71) Pl. DEC 20.00		CUSTOMER:		
72) Pl. DEC 20.00		APPROVAL:		
73) Pl. DEC 20.00		CUSTOMER:		
74) Pl. DEC 20.00		APPROVAL:		
75) Pl. DEC 20.00		CUSTOMER:		
76) Pl. DEC 20.00		APPROVAL:		
77) Pl. DEC 20.00		CUSTOMER:		
78) Pl. DEC 20.00		APPROVAL:		
79) Pl. DEC 20.00		CUSTOMER:		
80) Pl. DEC 20.00		APPROVAL:		
81) Pl. DEC 20.00		CUSTOMER:		
82) Pl. DEC 20.00		APPROVAL:		
83) Pl. DEC 20.00		CUSTOMER:		
84) Pl. DEC 20.00		APPROVAL:		
85) Pl. DEC 20.00		CUSTOMER:		
86) Pl. DEC 20.00		APPROVAL:		
87) Pl. DEC 20.00		CUSTOMER:		
88) Pl. DEC 20.00		APPROVAL:		
89) Pl. DEC 20.00		CUSTOMER:		
90) Pl. DEC 20.00		APPROVAL:		
91) Pl. DEC 20.00		CUSTOMER:		
92) Pl. DEC 20.00		APPROVAL:		
93) Pl. DEC 20.00		CUSTOMER:		
94) Pl. DEC 20.00		APPROVAL:		
95) Pl. DEC 20.00		CUSTOMER:		
96) Pl. DEC 20.00		APPROVAL:		
97) Pl. DEC 20.00		CUSTOMER:		
98) Pl. DEC 20.00		APPROVAL:		
99) Pl. DEC 20.00		CUSTOMER:		
100) Pl. DEC 20.00		APPROVAL:		
101) Pl. DEC 20.00		CUSTOMER:		
102) Pl. DEC 20.00		APPROVAL:		
103) Pl. DEC 20.00		CUSTOMER:		
104) Pl. DEC 20.00		APPROVAL:		
105) Pl. DEC 20.00		CUSTOMER:		
106) Pl. DEC 20.00		APPROVAL:		
107) Pl. DEC 20.00		CUSTOMER:		
108) Pl. DEC 20.00		APPROVAL:		
109) Pl. DEC 20.00		CUSTOMER:		
110) Pl. DEC 20.00		APPROVAL:		
111) Pl. DEC 20.00		CUSTOMER:		
112) Pl. DEC 20.00		APPROVAL:		
113) Pl. DEC 20.00		CUSTOMER:		
114) Pl. DEC 20.00		APPROVAL:		
115) Pl. DEC 20.00		CUSTOMER:		
116) Pl. DEC 20.00		APPROVAL:		
117) Pl. DEC 20.00		CUSTOMER:		
118) Pl. DEC 20.00		APPROVAL:		
119) Pl. DEC 20.00		CUSTOMER:		
120) Pl. DEC 20.00		APPROVAL:		
121) Pl. DEC 20.00		CUSTOMER:		
122) Pl. DEC 20.00		APPROVAL:		
123) Pl. DEC 20.00		CUSTOMER:		
124) Pl. DEC 20.00		APPROVAL:		
125) Pl. DEC 20.00		CUSTOMER:		
126) Pl. DEC 20.00		APPROVAL:		
127) Pl. DEC 20.00		CUSTOMER:		
128) Pl. DEC 20.00		APPROVAL:		
129) Pl. DEC 20.00		CUSTOMER:		
130) Pl. DEC 20.00		APPROVAL:		
131) Pl. DEC 20.00		CUSTOMER:		
132) Pl. DEC 20.00		APPROVAL:		
133) Pl. DEC 20.00		CUSTOMER:		
134) Pl. DEC 20.00		APPROVAL:		
135) Pl. DEC 20.00		CUSTOMER:		
136) Pl. DEC 20.00		APPROVAL:		
137) Pl. DEC 20.00		CUSTOMER:		
138) Pl. DEC 20.00		APPROVAL:		
139) Pl. DEC 20.00		CUSTOMER:		
140) Pl. DEC 20.00		APPROVAL:		
141) Pl. DEC 20.00		CUSTOMER:		
142) Pl. DEC 20.00		APPROVAL:		
143) Pl. DEC 20.00		CUSTOMER:		
144) Pl. DEC 20.00		APPROVAL:		
145) Pl. DEC 20.00		CUSTOMER:		
146) Pl. DEC 20.00		APPROVAL:		
147) Pl. DEC 20.00		CUSTOMER:		
148) Pl. DEC 20.00		APPROVAL:		
149) Pl. DEC 20.00		CUSTOMER:		
150) Pl. DEC 20.00		APPROVAL:		
151) Pl. DEC 20.00		CUSTOMER:		
152) Pl. DEC 20.00		APPROVAL:		
153) Pl. DEC 20.00		CUSTOMER:		
154) Pl. DEC 20.00		APPROVAL:		
155) Pl. DEC 20.00		CUSTOMER:		
156) Pl. DEC 20.00		APPROVAL:		
157) Pl. DEC 20.00		CUSTOMER:		
158) Pl. DEC 20.00		APPROVAL:		
159) Pl. DEC 20.00		CUSTOMER:		
160) Pl. DEC 20.00		APPROVAL:		
161) Pl. DEC 20.00		CUSTOMER:		
162) Pl. DEC 20.00		APPROVAL:		
163) Pl. DEC 20.00		CUSTOMER:		
164) Pl. DEC 20.00		APPROVAL:		
165) Pl. DEC 20.00		CUSTOMER:		
166) Pl. DEC 20.00		APPROVAL:		
167) Pl. DEC 20.00		CUSTOMER:		
168) Pl. DEC 20.00		APPROVAL:		
169) Pl. DEC 20.00		CUSTOMER:		
170) Pl. DEC 20.00		APPROVAL:		
171) Pl. DEC 20.00		CUSTOMER:		
172) Pl. DEC 20.00		APPROVAL:		
173) Pl. DEC 20.00		CUSTOMER:		
174) Pl. DEC 20.00		APPROVAL:		
175) Pl. DEC 20.00		CUSTOMER:		
176) Pl. DEC 20.00		APPROVAL:		
177) Pl. DEC 20.00		CUSTOMER:		
178) Pl. DEC 20.00		APPROVAL:		
179) Pl. DEC 20.00		CUSTOMER:		
180) Pl. DEC 20.00		APPROVAL:		
181) Pl. DEC 20.00		CUSTOMER:		
182) Pl. DEC 20.00		APPROVAL:		
183) Pl. DEC 20.00		CUSTOMER:		
184) Pl. DEC 20.00		APPROVAL:		
185) Pl. DEC 20.00		CUSTOMER:		
186) Pl. DEC 20.00		APPROVAL:		
187) Pl. DEC 20.00		CUSTOMER:		
188) Pl. DEC 20.00		APPROVAL:		
189) Pl. DEC 20.00		CUSTOMER:		
190) Pl. DEC 20.00		APPROVAL:		
191) Pl. DEC 20.00		CUSTOMER:		
192) Pl. DEC 20.00		APPROVAL:		
193) Pl. DEC 20.00		CUSTOMER:		
194) Pl. DEC 20.00		APPROVAL:		
195) Pl. DEC 20.00		CUSTOMER:		
196) Pl. DEC 20.00		APPROVAL:		
197) Pl. DEC 20.00		CUSTOMER:		
198) Pl. DEC 20.00		APPROVAL:		
199) Pl. DEC 20.00		CUSTOMER:		
200) Pl. DEC 20.00		APPROVAL:		



Компания «ЭлектроПласт» предлагает заключение долгосрочных отношений при поставках импортных электронных компонентов на взаимовыгодных условиях!

Наши преимущества:

- Оперативные поставки широкого спектра электронных компонентов отечественного и импортного производства напрямую от производителей и с крупнейших мировых складов;
- Поставка более 17-ти миллионов наименований электронных компонентов;
- Поставка сложных, дефицитных, либо снятых с производства позиций;
- Оперативные сроки поставки под заказ (от 5 рабочих дней);
- Экспресс доставка в любую точку России;
- Техническая поддержка проекта, помощь в подборе аналогов, поставка прототипов;
- Система менеджмента качества сертифицирована по Международному стандарту ISO 9001;
- Лицензия ФСБ на осуществление работ с использованием сведений, составляющих государственную тайну;
- Поставка специализированных компонентов (Xilinx, Altera, Analog Devices, Intersil, Interpoint, Microsemi, Aeroflex, Peregrine, Syfer, Eurofarad, Texas Instrument, Miteq, Cobham, E2V, MA-COM, Hittite, Mini-Circuits, General Dynamics и др.);

Помимо этого, одним из направлений компании «ЭлектроПласт» является направление «Источники питания». Мы предлагаем Вам помощь Конструкторского отдела:

- Подбор оптимального решения, техническое обоснование при выборе компонента;
- Подбор аналогов;
- Консультации по применению компонента;
- Поставка образцов и прототипов;
- Техническая поддержка проекта;
- Защита от снятия компонента с производства.



Как с нами связаться

Телефон: 8 (812) 309 58 32 (многоканальный)

Факс: 8 (812) 320-02-42

Электронная почта: org@eplast1.ru

Адрес: 198099, г. Санкт-Петербург, ул. Калинина, дом 2, корпус 4, литера А.