



RFFM8211

Wi-Fi Front End Module

Product Overview

The Qorvo® RFFM8211 is an integrated front end module (FEM) designed for Wi-Fi 802.11b-ac and Bluetooth® systems. The ultra-small form factor and integrated matching minimizes layout area in the application.

Performance is focused on optimizing the PA for a supply voltage range from 4.2 to 3V that balances linear performance vs a voltage drop inherent in battery operated systems. Capable for 5V operation as well . A low loss path for bi-directional transmit and receive of Bluetooth® is integrated in.

Integrated die level filtering for 2nd and 3rd harmonics as well as 5 GHz rejection for DBDC operation are included.

The RFFM8211 integrates a 2.4 GHz power amplifier (PA), regulator, single pole three throw switch (SP3T), bypassable low noise amplifier (LNA) and DC power detector into a single device

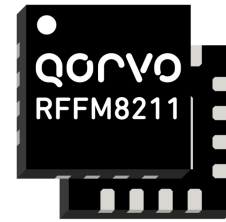

16 Pin 2.5x2.5mm QFN Package

Key Features

- 2412-2484 MHz
- P_{OUT} = +19dBm MCS9 VHT40 -35dB Dynamic EVM
- P_{OUT} = +20dBm MCS7 HT20 -30dB Dynamic EVM
- P_{OUT} = +22dBm 11b Spectral Mask Compliance
- Optimized for +3.6 V Operation
- Capable from <3.3 to 5V Operation
- 27 dB Tx Gain
- 2.5 dB Noise Figure
- 12 dB Rx Gain & 6 dB Bypass Loss
- Low Power Mode Available
- Integrated DC Power Detector

Functional Block Diagram

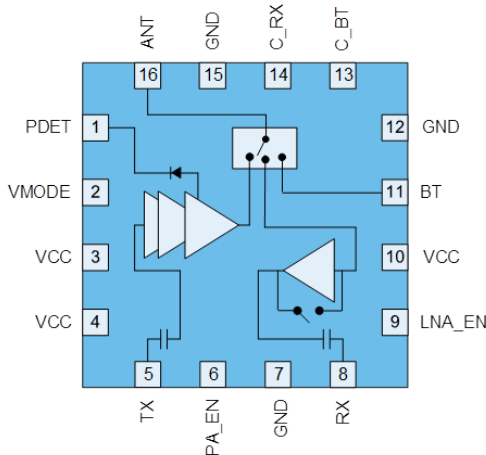

Top View

Applications

- Mobiles Devices
- Consumer Electronics
- Gaming
- Access Points
- Wireless Routers
- Residential Gateways
- Customer Premise Equipment
- Internet of Things

Ordering Information

Part Number	Description
RFFM8211SB	Sample bag with 5 pieces
RFFM8211SQ	Sample bag with 25 pieces
RFFM8211SR	7" reel with 100 pieces
RFFM8211TR7	7" reel with 2,500 pieces
RFFM8211PCK-410	Assembled Eval Board (3.6V) + 5 pcs
RFFM8211PCK-411	Assembled Eval Board (5V) + 5 pcs



Absolute Maximum Ratings

Parameter	Conditions	Rating
DC Supply Voltage		-0.5 to +6 V
Control Voltage		-0.5 to +5V
Storage Temperature		-40 to 150 °C
RF Input Power at TX	Into 50 Ω Load for 802.11b-ac (No Damage), Transmit Mode	+12 dBm
RF Input Power at ANT	(No Damage), Receive LNA On Mode, CW	+12 dBm

Exceeding any one or a combination of the Absolute Maximum Rating conditions may cause permanent damage to the device. Extended application of Absolute Maximum Rating conditions to the device may reduce device reliability.

Recommended Operating Conditions

Parameter	Min.	Typ.	Max.	Units
Operating Frequency	2412		2484	MHz
Device Voltage (V _{CC})	+3	+3.6	+4.2	V
Extended Device Voltage (V _{CC})	+3		+5	V
Control Voltage – High (PA_EN, LNA_EN & C_RX)	+2.8	+3.1	V _{CC}	V
Control Voltage – Low (PA_EN, LNA_EN & C_RX)		0	+0.2	V
T _{OPERATING} *	-10		+70	°C
Extended T _{OPERATING} *	-40		+85	°C

Electrical specifications are measured at specified test conditions. Specifications are not guaranteed over all recommended operating conditions. * T_{OPERATING} is temperature at the package ground.

Electrical Specifications

Parameter	Conditions	Min.	Typ.	Max.	Units
TRANSMIT (TX-ANT) MODE	Unless otherwise noted: V_{CC}=3.6V, T=+25°C, PA_EN=High, LNA_EN=Low, C_RX=Low				
11ac VHT40 Output Power	MCS8 256QAM	17.5	18.5		dBm
Dynamic EVM				-35	dB
11ac VHT20 Output Power	MCS8 256QAM	18	19		dBm
Dynamic EVM				-35	dB
11n HT20 Output Power	MCS7 64 QAM	19	20		dBm
Dynamic EVM				-30	dB
11n Spectral Mask	MCS0 HT20/40	20	21		dBm
Gain		24	27	31	dB
Gain Flatness	Across any 20 MHz Channel	-0.25		+0.25	dB
Gain Flatness	Across Operating Frequency	-0.5		+0.5	dB
TX Port Return Loss		8	10		dB
ANT Port Return Loss		12	17		dB



RFFM8211 Wi-Fi Front End Module

Parameter	Conditions	Min.	Typ.	Max.	Units
Quiescent Current	RF Off		120	180	mA
Operating Current	P _{OUT} = +19 dBm		180	230	mA
	P _{OUT} = +20 dBm		195	240	mA
2 nd Harmonics	P _{OUT} = +22 dBm 802.11b 1 Mbps, T _{OPERATING}		-10	-5	dBm/MHz
3 rd Harmonics	P _{OUT} = +22 dBm 802.11b 1 Mbps, T _{OPERATING}		-45	-30	dBm/MHz
ANT-RX Isolation		30	33	40	dB
DC Power Detect Voltage	RF Off	0.28	0.33	0.40	V
	P _{OUT} = +16.5 dBm	0.70	0.80	0.90	V
	P _{OUT} = +18.5 dBm	0.80	0.90	1.00	V
	P _{OUT} = +22 dBm	0.95	1.05	1.15	V
Variation from 0-360° Load Pull	3:1 VSWR	-1.5		+1.5	dB
TRANSMIT (TX-ANT) LOW POWER MODE	Unless otherwise noted: V_{CC}=3.6V, T=+25°C, PA_EN=Low, LNA_EN=High, C_RX=High				
11ac VHT40 Output Power	MCS8 256QAM	10	12		dBm
Dynamic EVM				-35	dB
11n HT20 Output Power	MCS7 64 QAM	12	14		dBm
Dynamic EVM				-30	dB
11n Spectral Mask	MCS0 HT20/40	12	14		dBm
Gain		23	26	30	dB
Gain Flatness	Across any 40 MHz Channel	-0.5		+0.5	dB
Rx Operating Current			22		mA
RECEIVE (ANT-RX) LNA ON MODE	Unless otherwise noted: V_{CC}=3.6V, T=+25°C, PA_EN=Low, LNA_EN=High, C_RX=High				
Gain		9	12	14	dB
Gain Flatness	Across any 20 MHz Channel	-0.25		+0.25	dB
Gain Flatness	Across Operating Frequency	-0.5		+0.5	dB
Noise Figure			2.5	3	dB
RX Port Return Loss		10	12	20	dB
ANT Port Return Loss		3	4	10	dB
Input P _{1dB}		-8	-4	0	dBm
LNA Turn On Time			200	500	nS
Rx Operating Current		7	10	13.5	mA
RECEIVE (ANT-RX) BYPASS MODE	Unless otherwise noted: V_{CC}=3.6V, T=+25°C, PA_EN=Low, LNA_EN=Low, C_RX=High				
Bypass Loss		4.5	6	8	dB
RX Port Return Loss		15	30	40	dB
ANT Port Return Loss		8	10	15	dB
Input P _{1dB}		+20	+25	+30	dBm
BLUETOOTH (ANT<->BT) MODE	Unless otherwise noted: V_{CC}=3.6V, T=+25°C, PA_EN=Low, LNA_EN=Low, C_RX=High				
Insertion Loss			0.6	1.2	dB
BT Port Return Loss		12	18	30	dB
ANT Port Return Loss		12	18	30	dB
Input P _{1dB}		+23	+27	+30	dBm



RFFM8211 Wi-Fi Front End Module

Parameter	Conditions	Min.	Typ.	Max.	Units
GENERAL SPECIFICATIONS		Unless otherwise noted: T=+25°C			
Leakage Current	PA, V _{CC} = 3.6V, RF Off, All control lines floating	0	0.5	10	μA
Control Current - High	C_RX & C_BT		5	60	μA
Control Current - Low	C_RX & C_BT		0.5	10	μA
Control Current	PA_EN	30	40	80	μA
Control Current	VMODE		300	500	μA
Control Current	LNA_EN	30	250	500	μA
Control Line Impedence	PA_EN		187		kΩ
Control Line Impedence	LNA_EN		228		kΩ
Control Line Impedence	C_RX & C_BT		27		MΩ
Switching Speed			100	500	nS
Switch Turn-On Time	PA + TX		200	500	nS
Ruggedness	10:1 VSWR				
Thermal Resistance, θ _{jc}	Junction to case		37		°C/W

Parameter	Conditions	Min.	Typ.	Max.	Units
TRANSMIT (TX-ANT) MODE		Unless otherwise noted: V _{CC} =5V, T=+25°C, PA_EN=High, LNA_EN=Low, C_RX=Low			
11ac VHT40 Output Power	MCS8 256QAM		20		dBm
Dynamic EVM				-35	dB
11ac VHT20 Output Power	MCS8 256QAM		21		dBm
Dynamic EVM				-35	dB
11n HT20 Output Power	MCS7 64 QAM		22		dBm
Dynamic EVM				-30	dB
11n Spectral Mask	MCS0 HT20/40		23		dBm
Gain		24	26	30	dB
Gain Flatness	Across Operating Frequency	-0.5		+0.5	dB
TX Port Return Loss		8	10		dB
ANT Port Return Loss		12	17		dB
Quiescent Current	RF Off		150		mA
Operating Current	P _{OUT} = +22 dBm		230		mA
2 nd Harmonics	P _{OUT} = +22 dBm 802.11b 1 Mbps		-10		dBm/MHz
3 rd Harmonics	P _{OUT} = +22 dBm 802.11b 1 Mbps, T _{OPERATING}		-28		dBm/MHz
DC Power Detect Voltage	RF Off		0.33		V
	P _{OUT} = +18.5 dBm		1.00		V
	P _{OUT} = +22 dBm		1.25		V
RECEIVE (ANT-RX) LNA ON MODE		Unless otherwise noted: V _{CC} =5V, T=+25°C, PA_EN=Low, LNA_EN=High, C_RX=High			
Gain		9	12	14	dB
Noise Figure			2.5	3	dB
RX Port Return Loss		10	12	20	dB
ANT Port Return Loss		3	4	10	dB

Logic Truth Table

Mode	PA_EN	LNA_EN	C_RX	C_BT	VMODE
Transmit Mode	High	Low	Low	Low	Low
Transmit Low Power Mode	High	Low	Low	Low	High
Receive LNA On Mode	Low	High	High	Low	Low
Receive Bypass Mode	Low	Low	High	Low	Low
Bluetooth Mode	Low	Low	Low	High	Low
Standby	Low	Low	Low	Low	Low
Not Supported	All Other States				

PA_EN and TX switch control are tied together internally..

Evaluation Board Schematic – RFFM8211PCK-410 3.6V

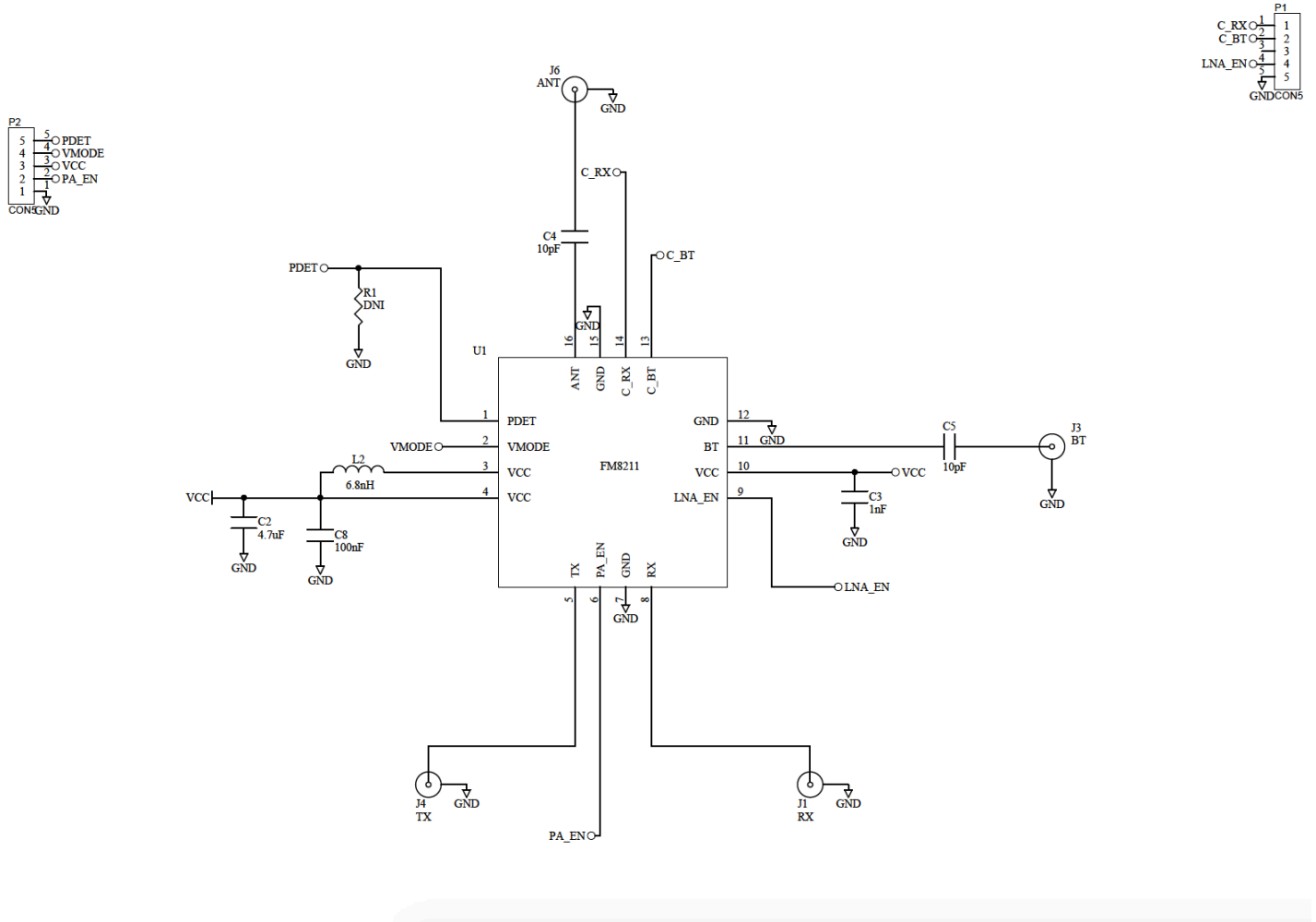

Bill of Material – RFFM8211PCK-410 3.6V

Ref. Des.	Value	Description	Manuf.	Part number
-	-	Printed Circuit Board		
U1	-	2.4GHz Wi-Fi Front End Module	Qorvo	RFFM8211
C8	0.1 µF	Capacitor, Chip, 10%, 6.3V, X5R, 0201	Murata	GRM033R60J104KE19J
C4, C5	10 pF	Capacitor, Chip, +/-0.5pF, 25V, COG, 0201	Taiyo Yuden	RM TMK063CG100DT-F
C3	1000 pF	Capacitor, Chip, 10%, 25V, X7R, 0201	Samsung EM	CL03B102KA3NNNC
C2	4.7 µF	Capacitor, Chip +80/-20%, 10V, Y5V, 0805	Taiyo Yuden	CE LMK212 F475ZG-T
L2	6.8 nH	Inductor, Chip, 5%, M?L, 0201	Taiyo Yuden	LG HK 0603 6N8J-T
R1	-	Do Not Install		

Evaluation Board Schematic – RFFM8211PCK-411 5V

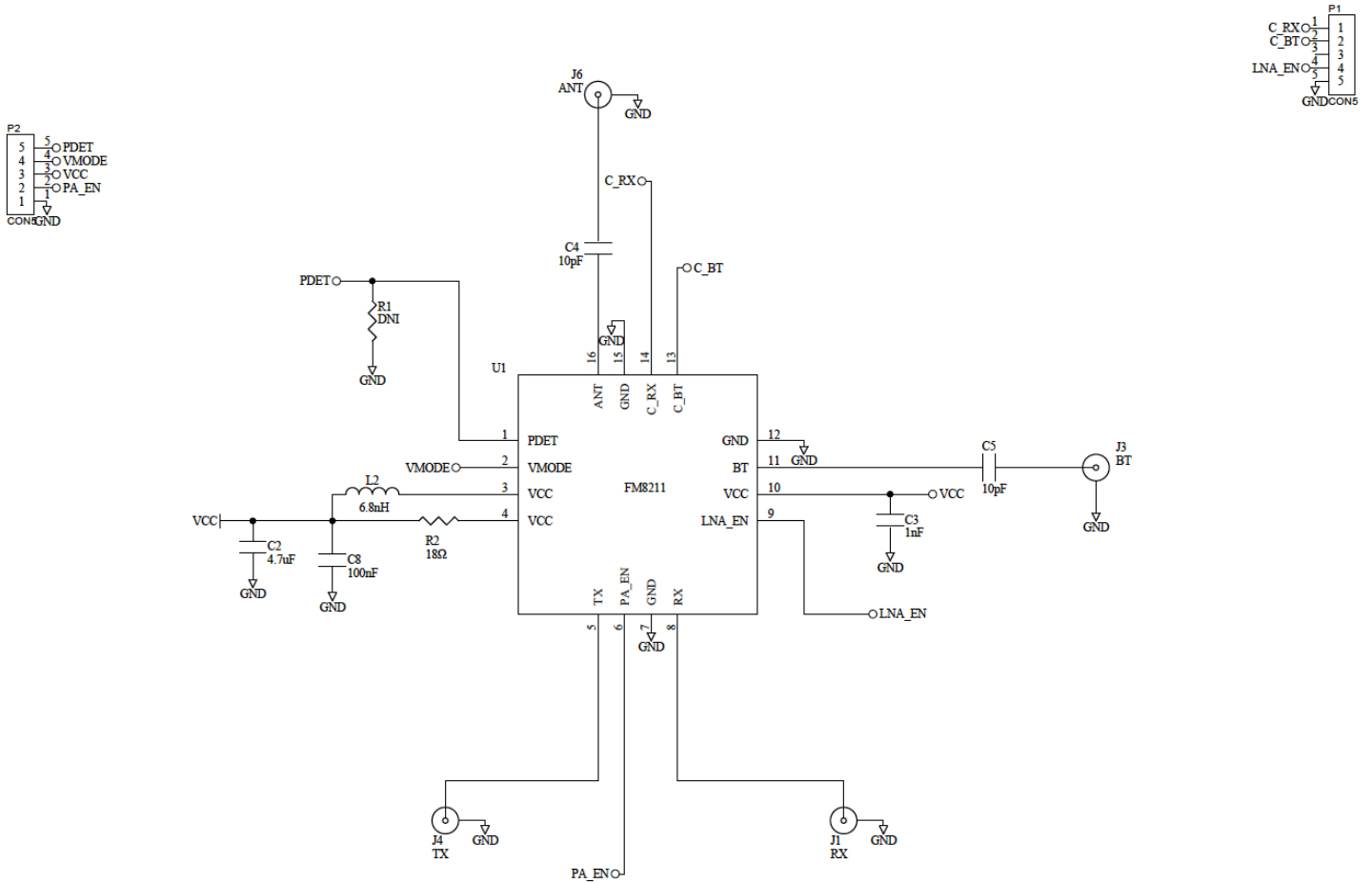

Bill of Material – RFFM8211PCK-411 5V

Ref. Des.	Value	Description	Manuf.	Part number
-	-	Printed Circuit Board		
U1	-	2.4GHz Wi-Fi Front End Module	Qorvo	RFFM8211
C8	100 nF	Capacitor, Chip		
C4, C5	10 pF	Capacitor, Chip, +/-0.5pF, 25V, C0G, 0201	Taiyo Yuden	RM TMK063CG100DT-F
C3	1000 pF	Capacitor, Chip, 10%, 25V, X7R, 0201	Samsung EM	CL03B102KA3NNNC
C2	4.7 μF	Capacitor, Chip +80/-20%, 10V, Y5V, 0805	Taiyo Yuden	CE LMK212 F475ZG-T
L2	6.8 nH	Inductor, Chip, 5%, M?L, 0201	Taiyo Yuden	LG HK 0603 6N8J-T
R2	18 Ω	Resistor, Chip		
R1	-	Do Not Install		

Pin Configuration and Description

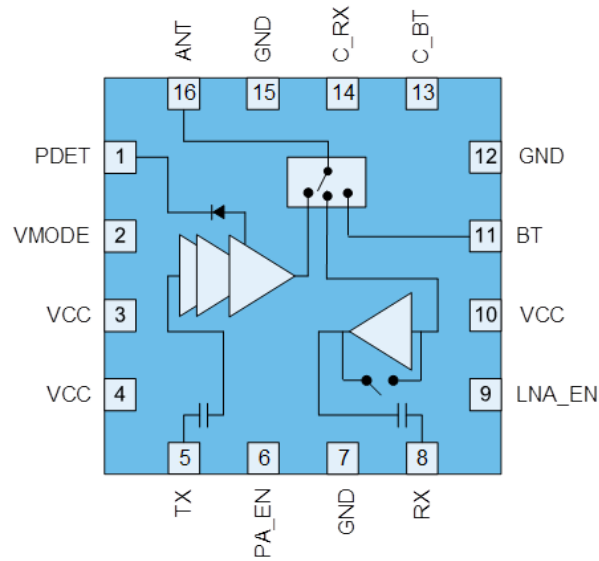

Top View

Pin Number	Label	Description
1	PDET	DC power detector. Provides an output voltage proportional to the RF output power level
2	VMODE	Control pin.
3	VCC	Output stage supply voltage
4	VCC	1 st stage supply voltage
5	TX	RF input. Internally matched to 50 Ω and DC blocked.
6	PA_EN	Control pin.
7	GND	No electrical connection.
8	RX	RF output from the low noise amplifier. Internally matched to 50 Ω and DC blocked.
9	LNA_EN	Control pin.
10	VCC	LNA supply voltage
11	BT	RF bidirectional port for Bluetooth®. Internally matched to 50Ω. An external DC block is required.
12	GND	No electrical connection.
13	C_BT	Control pin.
14	C_RX	Control pin.
15	GND	No electrical connection.
16	ANT	RF bi-directional antenna port. Internally matched to 50 Ω. An external DC block is required.
Backside Paddle	GND	RF/DC ground. Use recommended via pattern to minimize inductance and thermal resistance. See PCB Mounting Pattern for suggested footprint.

Mechanical Information

Dimensions and PCB Mounting Pattern

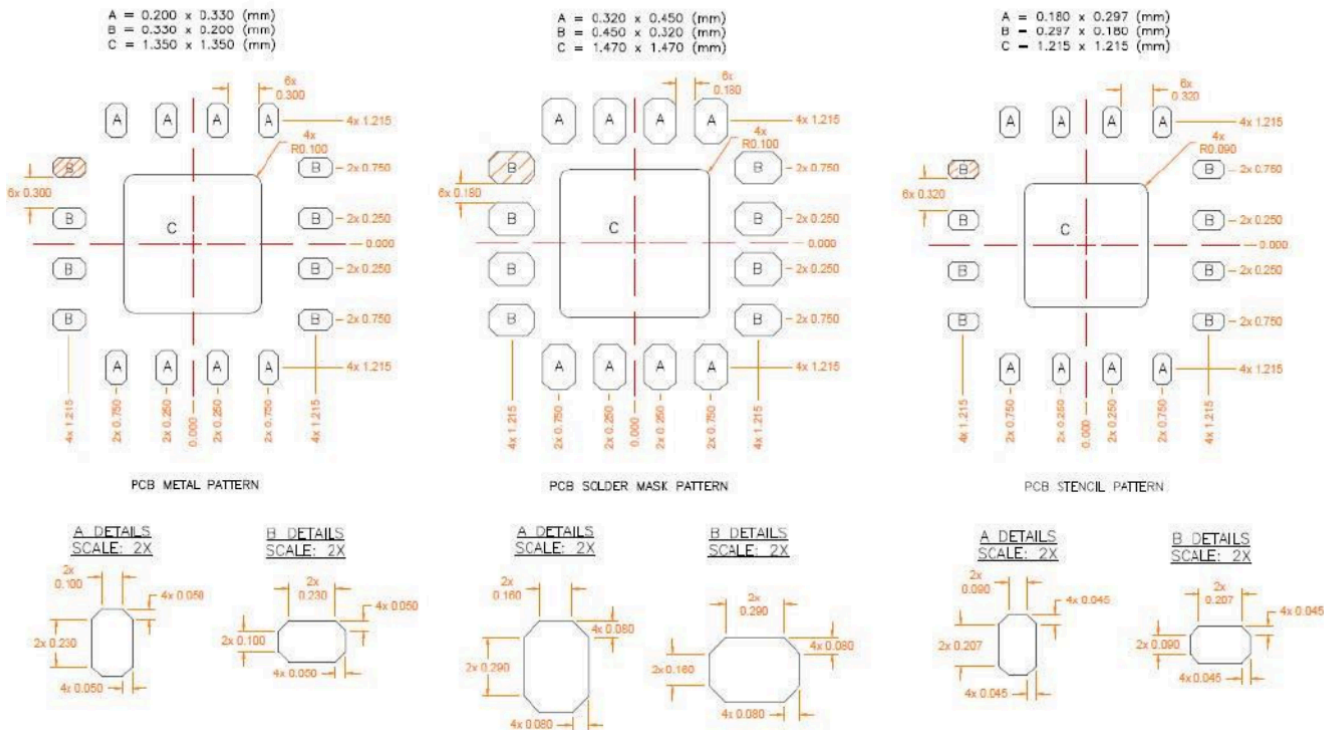
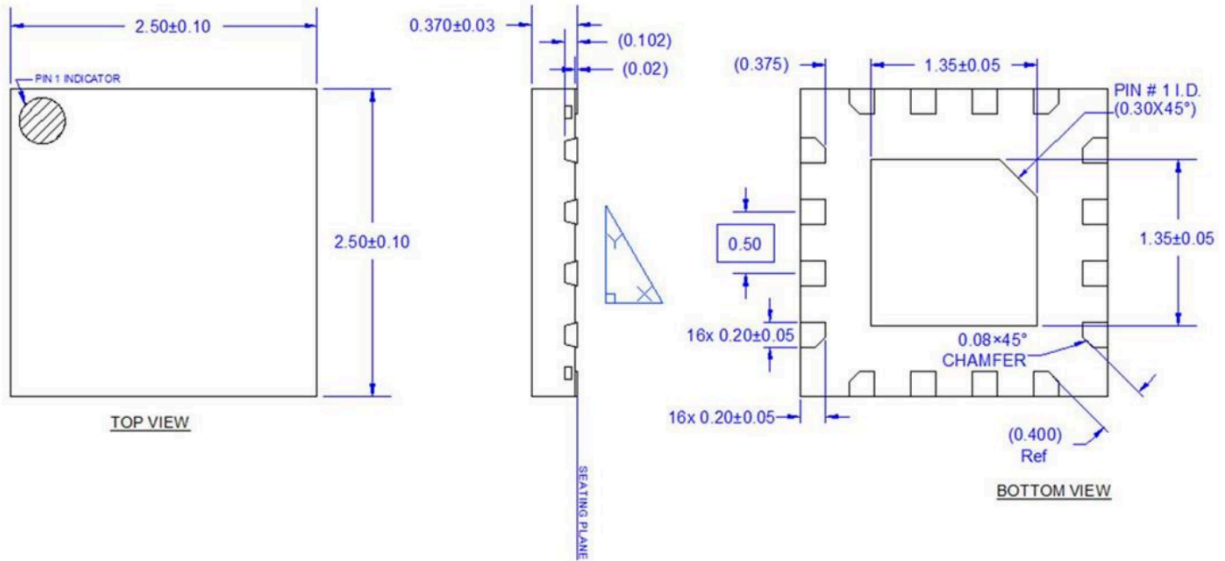

Notes:

1. All dimensions are in millimeters. Angles are in degrees.
2. Dimension and tolerance formats conform to ASME Y14.4M-1994.
3. The terminal #1 identifier and terminal numbering conform to JESD 95-1 SPP-012.

Handling Precautions

Parameter	Rating	Standard
ESD – Human Body Model (HBM)	Class 1C (1kV)	ANSI/ESD/JEDEC JS-001
ESD – Charged Device Model (CDM)	Class C3 (1kV)	JESD22-C101
MSL – Moisture Sensitivity Level	Level 2	IPC/JEDEC J-STD-020



Caution!

ESD sensitive device

Solderability

Compatible with both lead-free (260 °C max. reflow temperature) and tin/lead (245 °C max. reflow temperature) soldering processes.

Package lead plating: Electrolytic Ni/Pd/AU

RoHS Compliance

This part is compliant with the 2011/65/EU RoHS directive (Restrictions on the Use of Certain Hazardous Substances in Electrical and Electronic Equipment), as amended by Directive 2015/863/EU.

This product also has the following attributes:

- Lead free
- Halogen Free (Chlorine, Bromine)
- Antimony Free
- TBBP-A (C₁₅H₁₂Br₄O₂) Free
- SVHC Free



Contact Information

For the latest specifications, additional product information, worldwide sales and distribution locations:

Web: www.qorvo.com

Tel: 1-844-890-8163

Email: customer.support@qorvo.com

Important Notice

The information contained herein is believed to be reliable; however, Qorvo makes no warranties regarding the information contained herein and assumes no responsibility or liability whatsoever for the use of the information contained herein. All information contained herein is subject to change without notice. Customers should obtain and verify the latest relevant information before placing orders for Qorvo products. The information contained herein or any use of such information does not grant, explicitly or implicitly, to any party any patent rights, licenses, or any other intellectual property rights, whether with regard to such information itself or anything described by such information. **THIS INFORMATION DOES NOT CONSTITUTE A WARRANTY WITH RESPECT TO THE PRODUCTS DESCRIBED HEREIN, AND QORVO HEREBY DISCLAIMS ANY AND ALL WARRANTIES WITH RESPECT TO SUCH PRODUCTS WHETHER EXPRESS OR IMPLIED BY LAW, COURSE OF DEALING, COURSE OF PERFORMANCE, USAGE OF TRADE OR OTHERWISE, INCLUDING THE IMPLIED WARRANTIES OF MERCHANTABILITY AND FITNESS FOR A PARTICULAR PURPOSE.**

Without limiting the generality of the foregoing, Qorvo products are not warranted or authorized for use as critical components in medical, life-saving, or life-sustaining applications, or other applications where a failure would reasonably be expected to cause severe personal injury or death.

Copyright 2018 © Qorvo, Inc. | Qorvo is a registered trademark of Qorvo, Inc.



Компания «ЭлектроПласт» предлагает заключение долгосрочных отношений при поставках импортных электронных компонентов на взаимовыгодных условиях!

Наши преимущества:

- Оперативные поставки широкого спектра электронных компонентов отечественного и импортного производства напрямую от производителей и с крупнейших мировых складов;
- Поставка более 17-ти миллионов наименований электронных компонентов;
- Поставка сложных, дефицитных, либо снятых с производства позиций;
- Оперативные сроки поставки под заказ (от 5 рабочих дней);
- Экспресс доставка в любую точку России;
- Техническая поддержка проекта, помощь в подборе аналогов, поставка прототипов;
- Система менеджмента качества сертифицирована по Международному стандарту ISO 9001;
- Лицензия ФСБ на осуществление работ с использованием сведений, составляющих государственную тайну;
- Поставка специализированных компонентов (Xilinx, Altera, Analog Devices, Intersil, Interpoint, Microsemi, Aeroflex, Peregrine, Syfer, Eurofarad, Texas Instrument, Miteq, Cobham, E2V, MA-COM, Hittite, Mini-Circuits, General Dynamics и др.);

Помимо этого, одним из направлений компании «ЭлектроПласт» является направление «Источники питания». Мы предлагаем Вам помощь Конструкторского отдела:

- Подбор оптимального решения, техническое обоснование при выборе компонента;
- Подбор аналогов;
- Консультации по применению компонента;
- Поставка образцов и прототипов;
- Техническая поддержка проекта;
- Защита от снятия компонента с производства.



Как с нами связаться

Телефон: 8 (812) 309 58 32 (многоканальный)

Факс: 8 (812) 320-02-42

Электронная почта: org@eplast1.ru

Адрес: 198099, г. Санкт-Петербург, ул. Калинина, дом 2, корпус 4, литера А.