

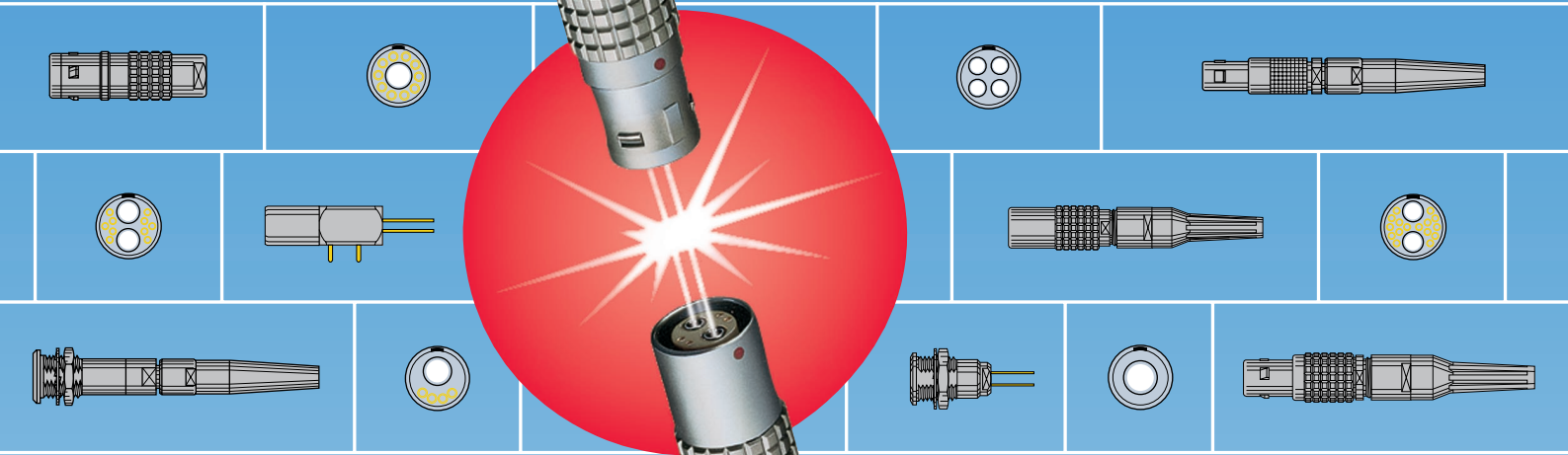

LEMO®

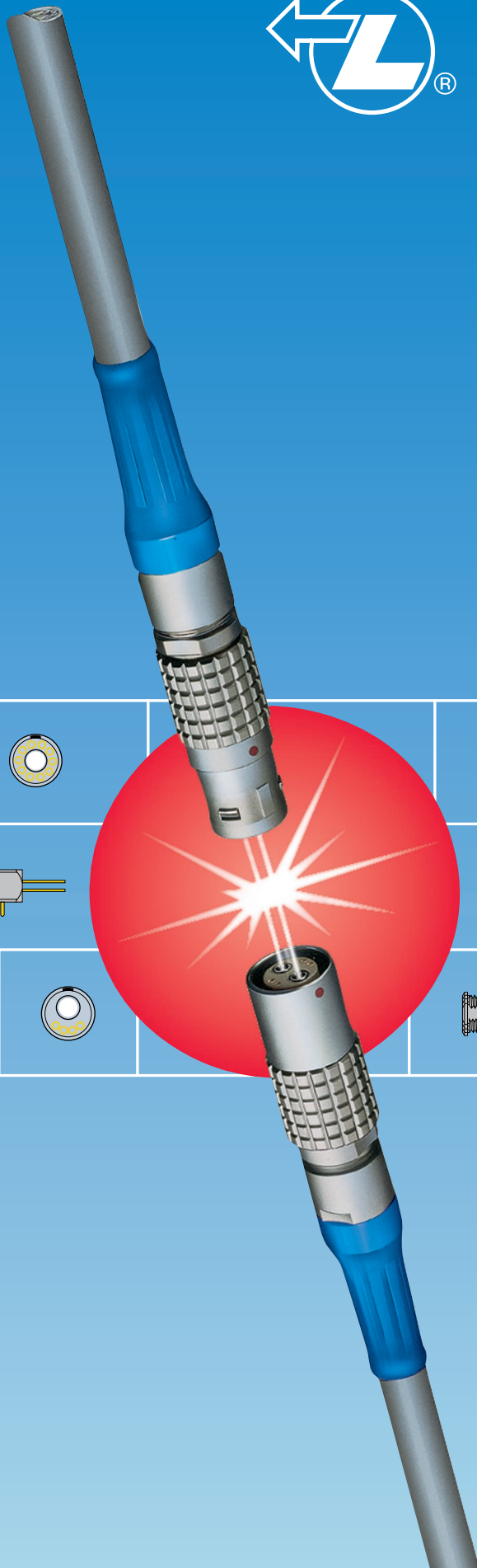

Single, Multi & Hybrid
Fibre Optic
Connectors

Dear Customers,

As far as data transmission is concerned, the superior characteristics of fibre optics compared to electrical cables are clearly recognised today.

The advantages of fibre optics include a transmission capacity 10 times greater than that of conventional coaxial cables, in only one tenth of the size. The reduced weight and space requirements make handling and line installation much easier. Furthermore, fibre optics is characterized by low signal amplitude loss, no susceptibility to electromagnetic interference, and an absence of interference between neighbouring lines. It also offers greater security due to the difficulty of intercepting optical signals.

The growing number of applications is more and more varied, and the annual growth rate of fibre optics is greater than 10%. Current applications of fibre optics include: telemetry, process control, data transmission, cable and closed circuit television, as well as laser signal transmission in medical applications.

However, most systems equipped with fibre optics also require simultaneous electrical energy for control operations and power supply. Current practice involves the use of separate electrical and fibre optic connectors.

The new technology developed by LEMO greatly simplifies this practice by combining electrical and fibre optic signals in a single connector.

LEMO can now offer you a full range of mixed electrical/fibre optic connectors for singlemode or multi-mode transmission. This product range is available with metal or plastic outer shells, as well as in a watertight version.

The range is completed by the addition of a single channel fibre optic connector series. All LEMO fibre optic connectors use a plug and socket push-pull self-latching connection system, obviating the need for plug to plug adaptors. This is a major advantage of the LEMO technology over its competitors.

With the aim of providing the best possible answers to your fibre optic needs, LEMO has established an important research and development facility to provide quick and effective solutions to your design requirements.

LEMO ISO 9001 certified has been improving its "quality culture" with the aim of reaching TQM. Offering zero defect products with due regard to the environment and meeting delivery requirements, are LEMO's two main concerns.



LEMO SA
General Management

Table of Contents

General Production Programme	page	3
Main Characteristics and Types		3
Series and Types		4
LEMO's Push-Pull Self-Latching Connection System		5
Fibre Optic Connectors Production Programme		6
Introduction		7
General Characteristics	Selection of the LEMO Fibre Optic Contacts, Series and Contact Configurations	8
	Acceptable Cable Diameter	9
	Selection of Electrical Contact Types	9
	Part Numbering System	10
00 Series	Interconnections	13
	Model Description	13
	Part Section Showing Internal Components	14
	Technical Characteristics	14
	Alignment Key and Polarized Keying Systems	14
	Part Number Example	15
	Models - Series	16
	Fibre Type	17
	Housing, Cable Fixing Type, Bend Relief, Tooling, Panel Cut-Outs	18
0B Series	Interconnections	21
	Model Description	21
	Part Section Showing Internal Components	22
	Technical Characteristics	22
	Alignment Key and Polarized Keying Systems	22
	Part Number Example	23
	Models - Series	24
	Fibre Type, Housing	25
	Bend Relief, Tooling, Panel Cut-Outs	26
0K Series	Interconnections	29
	Model Description	29
	Part Section Showing Internal Components	30
	Technical Characteristics	30
	Alignment Key and Polarized Keying Systems	30
	Part Number Example	31
	Models - Series	32
	Fibre Type	32
	Housing, Bend Relief, Tooling, Panel Cut-Outs	33
2B to 5B Series	Interconnections	37
	Model Description	37
	Part Section Showing Internal Components	38
	Technical Characteristics	38
	Alignment Key and Polarized Keying Systems	38
	Part Number Example	39
	Models - Series	40
	Tooling, Panel Cut-Outs	45
2K to 5K Series	Interconnections	47
	Model Description	47
	Part Section Showing Internal Components	48
	Technical Characteristics	48
	Alignment Key and Polarized Keying Systems	48
	Part Number Example	49
	Models - Series	50
	Tooling, Panel Cut-Outs	53
	Types (2B-5B and 2K-5K series)	55
	Housing, Electrical Contact (2B-5B and 2K-5K series)	58
	Collets (2B-5B and 2K-5K series)	59
	Variant (2B-5B and 2K-5K series)	61

Table of Contents

3K.93C Series	Interconnections	65
	Model Description	65
	Part Section Showing Internal Components	66
	Technical Characteristics	66
	Alignment Key and Polarized Keying Systems	67
	Part Number Example	67
	Models - Series	68
	Types	71
	Fibre Optic Contact, Accessories	72
	Tooling	74
	Fibre Optic Tooling, Crimping Tools for Electrical Contacts	75
	Termination Instruction, Panel Cut-Outs	76
F1 Fibre Optic Contact	Introduction, Part Section Showing Internal Components	77
	Technical Characteristics, Part Number Example	77
	Model - FO Contact Type, Fibre Type	78
F2 Fibre Optic Contact	Introduction, Part Section Showing Internal Components, Technical Characteristics	79
	Part Number Example, Model - FO Contact Type, Fibre Type	80
	Cable Fixing Type, Accessory	81
	Insertion and Extraction of the Fibre Optic Contacts	82
Accessories	Insulators, Crimp Electrical Contacts	85
	Caps	86
	Bend Reliefs	91
	Insulating Washers, Double Panel Washers	93
	Locking Washers, Tapered Washers, Hexagonal Nuts	94
	Notched Nuts, Conical Nuts, Round Nuts	95
	Earthing Washers	96
Tooling	Spanners	97
	Pliers, Taps	99
	Crimping Tools for Electrical Contacts, Positioners, Turrets	100
	Extraction Tools, Retention Testing Tools	101
Tools for type C Coaxial Contacts	Crimping Tool, Dies, Extractors	102
Fibre Optic Tooling	Complete Workstation	103
	Crimping Tool, Epoxy Curing Jig, Epoxy Curing Oven, Polishing Tool	104
	Fibre Inspection Microscope, Microscope Adaptor, Extractor	105
	F2 Contact Alignment Device, F4 Contact Alignment Device	105
	Cleaning Tool, Cleaning Kit	106
Technical Characteristics	Outer shell	107
	Insulator	108
	Fibre Optic Contacts	109
	Electrical Contact	112
	Cable Fixing	115
	Preferred Fibre Optic Cable Types	118

General Production Program

Connectors

- Unipole from 2 to 150 Amps
- Coaxial 50 and 75 Ω
- Coaxial 50 Ω (NIM-CAMAC)
- Coaxial 50 Ω for frequency → 12 GHz
- Multicoaxial 50 and 75 Ω
- Multipole from 2 to 106 contacts
- High Voltage 3, 5, 8, 10, 15, 30 and 50 kV cc
- Multi High Voltage 3, 5, and 10 kV cc
- Triaxial 50 and 75 Ω
- Quadrax
- Mixed: High Voltage (LV) + Low Voltage (LV)
- Mixed: Coax + LV
- Mixed: Triax + LV
- Thermocouple
- Multithermocouple
- Fibre optic single-mode
- Fibre optic multi-mode
- Mixed: fibre optic + LV
- Mixed: fibre optic + coax + LV
- Fluidic
- Multifluidic
- Mixed: fluidic + LV
- Subminiature
- Miniature
- Printed circuit board
- Remote handling
- Watertight
- Sealed (pressure and/or vacuum)
- With plastic outer shell
- With aluminium outer shell
- With stainless steel outer shell
- With special radiation resistant insulator material
- With screw thread coupling for very high pressure
- With microswitch

Patch Panels

- For audio-mono applications: triax
- For audio-mono applications: 3 contacts
- For audio-stereo applications: quadrax
- For audio-stereo applications: 6 contacts
- For video applications: coax 75 Ω

Patch Panels

- For video HDTV applications: 3 coax 75 Ω + 2LV
- For fibre optic applications

Adaptors

- For BNC, C, UHF, N, CINCH, GEN-RADIO connectors
- For TNC, SMA connectors

Accessories

- Insulator for crimp contacts
- Crimp contacts
- Coaxial contacts
- Triaxial contacts
- Fibre optic contacts
- Fibre optic ferrules
- Caps and bend reliefs
- Insulating washers
- Double plastic panel washers
- Locking washers
- Tapered washers
- Hexagonal nuts
- Conical nuts
- Round nuts
- Notched nuts
- Earthing washers
- Lead-through with cable collet

Tooling



- Spanners
- Spanners for assembling plug
- Assembly tool
- Pliers
- Tap
- Crimping tools
- Positioners
- Crimping dies
- Extractors
- Insertion testing tool for crimp contacts
- Fibre optic termination workstation
- Fibre optic polishing tools

On request

- Filtered connectors
- Connectors with special alloy housing
- Mixed special connectors
- Assembly onto cable

● Connectors, accessories and tools found in this catalogue.

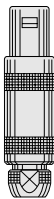
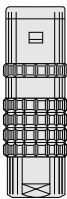
Main Characteristics and Types

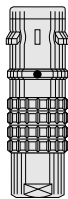
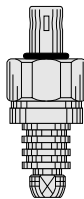
					
Series	STANDARD	WATERTIGHT	KEYED	KEYED WATERTIGHT	SCREW
	01 (Minax)	0E to 6E	00 (multipole)	0K to 5K	03
	00 (NIM-CAMAC)	3T	0B to 5B	0F to 5F	0V to 5V
	00 (unipole)	4M	2G/5G	2N to 5N	0W to 5W
	05 / R0				2U to 5U
	0S to 6S				
	0A / 4A				
	1D / 2C				
	1Y-3Y-6Y				
Latching	Push-Pull				Screw
Key	Stepped insulator (Half-Moon)		Key (G) or other key-way code		Key (G) or stepped insulator (Half-Moon)
Shell	Metal or plastic	Metal	Metal or plastic	Metal	Metal
Insulator	Hermaphroditic or cylindrical		Cylindrical		Hermaphroditic or cylindrical
Contact	Solder or print		Solder, crimp or print		Solder (crimp or print)

Series and Types

	Series	Types																				
		Unipole	Coaxial 50 Ω	Coaxial 75 Ω	Multipole	High Voltage	Triaxial 50 Ω	Triaxial 75 Ω	Quadtrax	Multi HV	Multi Coaxial	Mixed HV+LV	Mixed Coax+LV	Mixed Triax+LV	Fibre Optic	Multi FO	Mixed FO+LV+...	Fluidic	Multi fluidic	Mixed fluidic+LV	Thermocouple	
Standard	01		●																			
	00	●	●				●											●				
	05					●																
	R0		●																			
	0A		●	●																		
	0S	●	●		●	●	●															●
	1S	●	●	●	●	●	●															●
	2S	●	●	●	●	●	●	●				●										●
	3S	●	●	●	●	●	●	●		●		●	●									
	4S	●	●	●	●	●	●	●		●	●	●	●									
	5S	●	●	●	●					●	●	●	●									
	6S				●						●		●									
	1D								●													
	2C		●		●																	
4A							●															
1Y-3Y-6Y					●																	
Watertight	0E	●	●		●	●															●	
	1E	●	●	●	●	●															●	
	2E	●	●	●	●	●	●				●										●	
	3E	●	●	●	●	●	●		●		●	●										
	4E	●	●	●	●		●	●				●	●									
	5E	●			●				●	●	●	●	●									
	6E				●					●		●	●									
	3T			●				●														
4M						●	●															
Keyed	00				●										●						●	
	0B				●										●			●			●	
	1B				●						●										●	
	2B				●					●	●	●	●	●		●			●	●	●	
	3B				●						●	●	●	●	●	●	●		●	●	●	
	4B				●					●	●	●	●	●	●	●	●		●	●		
	5B				●					●	●	●	●	●	●	●	●					
	2G				●																	
5G								●														
Keyed watertight	0K				●									●				●			●	
	1K				●						●										●	
	2K				●					●	●	●	●			●			●	●	●	
	3K			●	●					●	●	●	●	●	●	●	●		●	●	●	
	4K				●				●	●	●	●	●	●	●	●	●		●	●		
	5K				●				●	●	●	●	●	●	●	●	●					
	0F to 5F				●																	
	2N to 5N	●	●	●	●		●	●								●	●					
Screw	03		●		●																	
	0V	●	●		●		●														●	
	1V	●	●	●	●		●														●	
	2V	●	●	●	●		●	●			●										●	
	3V	●	●	●	●		●	●	●		●	●										
	4V	●	●	●	●		●	●			●	●	●									
	5V	●			●				●	●	●	●	●									
	0W to 5W				●						●	●	●	●		●	●			●	●	
	2U to 5U				●										●	●	●					

Note: ● = included in this catalogue, ● = available but not included in this catalogue.

LEMO's Push-Pull Self-Latching Connection System

This self-latching system is renowned worldwide for its easy and quick mating and unmating features. It provides absolute security against vibration, shock or pull on the cable, and facilitates operation in a very limited space.

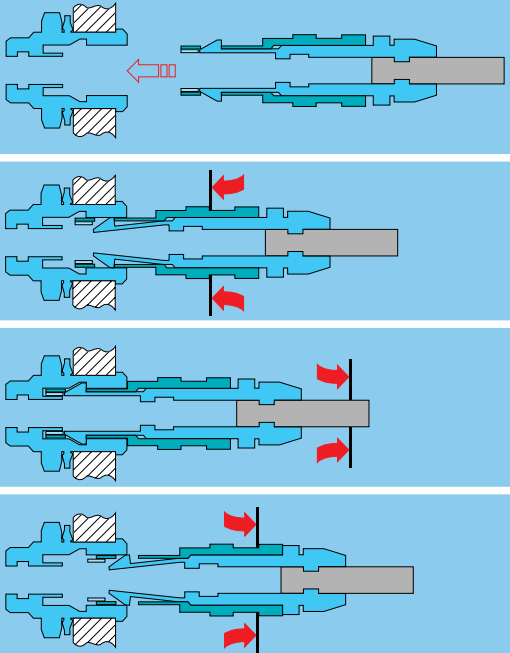

The LEMO Push-Pull self-latching system allows the connector to be mated by simply pushing the plug axially into socket.

Once firmly latched, connection cannot be broken by pulling on the cable or any other component part other than the outer release sleeve.

When required, the connector is disengaged by a single axial pull on the outer release sleeve. This first disengages the latches and then withdraws the plug from the socket.

Mechanical latching characteristics

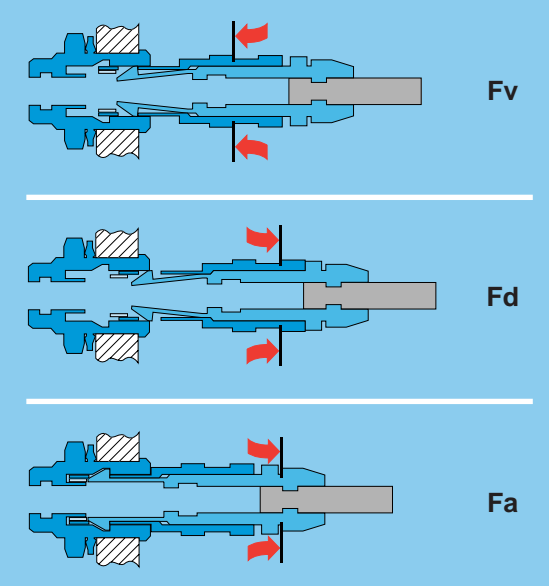

F_v

F_d

F_a

00, B series

Force (N)	Series					
	00	0B	2B	3B	4B	5B
F _v	9	10	15	17	39	48
F _d	7	8	12	14	38	38
F _a	120	250	300	550	700	800

K watertight series

Force (N)	Series				
	0K	2K	3K	4K	5K
F _v	14	20	32	65	85
F _d	9	13	25	40	60
F _a	250	400	550	700	800

Notes: Forces were measured on outer shells **not fitted with contacts**.



F_v: average latching force

F_d: average unmating force
with axial pull on the outer shell

F_a: average pull force
with axial pull on the collet nut

Fibre Optic Connectors Production Program

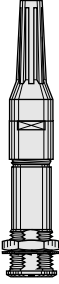
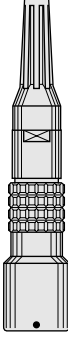
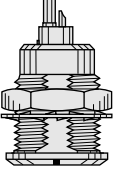
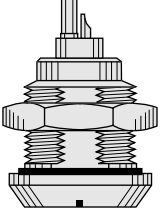
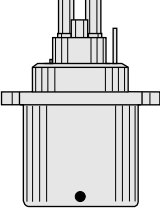
The production program is divided into 12 series of connectors. Their main characteristics and applications are shown below.

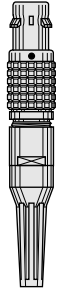
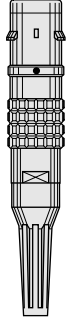
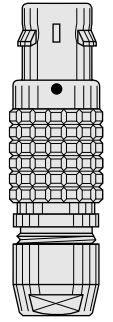
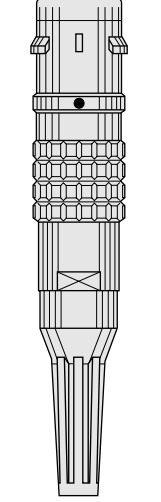
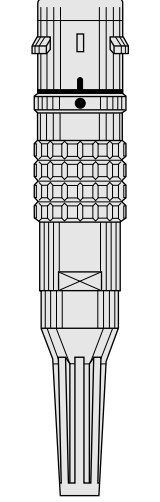
						
						
Series	00	0B	0K	2B to 5B	2K to 5K	3K.93C
Latching	Push-Pull					With «W» key-way
Shell	Metal			Metal or plastic	Metal	
Feature	Miniature		Watertight to IP68		Watertight to IP68	Watertight to IP68
Cable Construction	Single fibre			Multi fibre or Mixed optical/electrical		Mixed HDTV optical/electrical
Contact Type	F4	F3	F2	F1	F2	F2
Fibre Type	Single-mode or Multi-mode fibres ≤ 100/140µm	Multi-mode fibres ≥ 100/140µm	Single-mode or Multi-mode fibres ≤ 100/140µm	Multi-mode fibres ≥ 100/140µm	Single-mode or Multi-mode fibres ≤ 100/140µm	Single-mode or Multi-mode fibres ≤ 100/140µm
Mean insertion loss	0.10 dB (s/m) 0.25 dB (m/m)	1.13 dB	0.10 dB (s/m) 0.25 dB (m/m)	1.13 dB	0.10 dB (s/m) 0.25 dB (m/m)	0.10 dB (s/m) 0.25 dB (m/m)
Ferrule Material	Ceramic	Ceramic or metal	Ceramic	Ceramic or metal	Ceramic	Ceramic
Interface Type	Spherical with physical contact of the fibre end face (PC)	Spherical, non-contact with controlled gap of the fibre end face	Spherical with physical contact of the fibre end face (PC)	Spherical, non-contact with controlled gap of the fibre end face	Spherical with physical contact of the fibre end face (PC)	Spherical with physical contact of the fibre end face (PC)
Page	11 to 18	19 to 26	27 to 34	35 to 46	47 to 54	63 to 76

Introduction

This catalog gives the complete description of LEMO fibre optic connectors. Our manufacturing program has been extended to 12 series with specific mating and environmental characteristics.

Each series includes a wide variety of plugs, sockets or housings for electro-optic devices available in a large choice of combinations of fibre optic and electrical contacts within the same housing. Shells are adapted to all round cables to a maximum diameter of 25 mm.

LEMO connectors feature ceramic or metal ferrules for the fibre optic contacts to provide alignment for both single-mode and multi-mode fibres.

They are manufactured to the highest precision in order to ensure optimum optical performances even in the most severe applications.

Numerous accessories as well as a complete range of tools for fibre optic termination, are available.

The 00 Series

The characteristic feature of this connector series is the small size requiring minimum mounting space requirement.

Connectors are suitable for use with single fibre cables fitted with single-mode or multi-mode fibres.

The 0B Series

A simple and proven construction with ceramic or metallic ferrules in a fibre optic contact primarily intended for use with large size multi-mode fibres ranging from 140 to 1500 micron external diameters.

The 0K Series

This series is watertight (IEC 60529/IP 66-IP 68) and is ideal for use in harsh environments.

It uses the standard LEMO F2 fibre optic contact which has undergone extensive mechanical, optical and environmental testing.

Connectors are suitable for use with single fibre cables fitted with single-mode or multi-mode fibres.

Propagation of Light and Fibre Type

The diagrams show the typical transmission characteristic of single-mode and multi-mode fibres. In multi-mode fibres, the effect of modal dispersion causes a spread in the received pulse and therefore limits the bandwidth of the transmission system (Fig. 1).

If the fibre core is $< 10 \mu\text{m}$ and the wavelength is $\geq 1300 \text{ nm}$, then only the fundamental mode is transmitted in the single-mode fibre (Fig. 2).

The dispersion effects of single-mode fibres are very small and consequently they offer higher bandwidths when compared with multi-mode fibres. However, multi-mode fibres are usually ideal for short distance applications because they require less input optical power and can be driven by simple low cost LEDs.

The 2B to 5B Series

These connectors series range from 2B to 5B, and have been designed to work with LEMO F1 or F2 type fibre optic contacts. They are suitable for use with multi fibre or mixed fibre optical/electrical cables fitted with single-mode or multi-mode fibres up to 1500 micron in diameter. The connectors offer a variety of features:

- alignment key preventing all errors in alignment;
- polarized keying system, the various keying alternatives prevent unwanted cross mating of otherwise similar connectors;
- higher contact density; and
- possible use of crimp contacts to reduce cable assembly time.

The 2K to 5K Series

This product family includes the 2K to 5K series, and are watertight (IEC 60529/IP 66-IP 68) available in the same types as the 2B to 5B series. The connectors are ideal for use in harsh environments.

The video HDTV 3K.93C Series

This new range of high performance fibre optic camera connectors has been developed to meet the needs of the new generation of digital TV cameras. Contact configuration includes 2 fibre optic contacts for single-mode fibres, 2 electrical contacts for power and 2 electrical contacts for signal. This series conforms to the Japanese ARIB technical report BTA S-1005B, to the ANSI/SMPTE 304 M-1998 and 311M-1998 standards and to the European EBU Technical Recommendation R100-1999. Connectors are qualified for use in UL approved equipment such as those specified in UL 1419 «Professional Video and Audio Equipment»

CE marking

CE marking means that the appliance or equipment bearing it complies with the protection requirements of one or several European safety directives.

CE marking applies to complete products or equipment, but not to optical/electromechanical components, such as connectors.

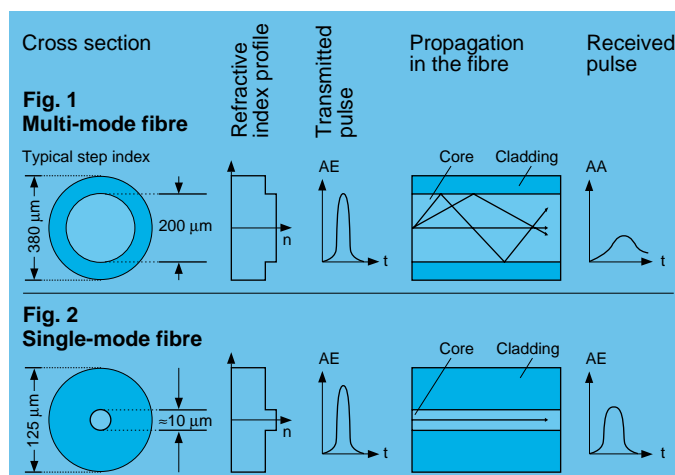

General Characteristics

Selection of the LEMO Fibre Optic Contacts

In order to ensure the highest technical performance and to provide the optimum solution for a diversity of applications, LEMO has developed four types of fibre optic contacts; designated **F1**, **F2**, **F3**, and **F4**. These contacts are designed to operate with single fibre, multi fibre, and mixed fibre optical/electrical cable constructions and cater to single and multi-mode fibres from 9/125 to 1500 µm diameter.

The choice of fibre optic contacts depends upon the following criteria:
 – Cable construction (single fibre, multi fibre, mixed optical/electrical)
 – Fibre type (single-mode or multi-mode).

The table below shows the suitability of each contact type with different fibres and cables. Note that the multi fibre cable can contain many types of optic fibres or a group of fibres and electrical cables leading to mixed optical/electrical connectors.

Contact type	Cable Structure		Fibre Types and dimensions			
	 single fibre	 multi fibre or mixed	 single-mode	multi-mode		
				≤ 100/140µm	≥ 100/140µm	
 F1						
 F2						
 F3						
 F4						

Series and contact configurations

Single and Multi F.O.

Number of F.O. contacts	Series							
	00	0B	0K	2B-2K	3B-3K	4B-4K	5B-5K	3K.93C
1	●	●	●					
2					●			
4						●		
10							●	
14							●	

Note: ● = available contact configuration

Mixed F.O. + L.V.

Number of F.O. contacts	Number of L.V. electrical contacts	Series						
		00	0B	0K	2B-2K	3B-3K	4B-4K	5B-5K
1	2, 4, 6 or 10				●			
1	22					●		
2	4, 6, 10 or 16					●		
2	6, 7, 12, 16 or 18						●	
3	6 or 12						●	
3	10							●
4	5 or 9						●	
9	3							●

Mixed F.O. + L.V. + H.V.

Number of F.O. contacts	Number of L.V. electrical contacts	Number of H.V. electrical contacts	Series							
			00	0B	0K	2B-2K	3B-3K	4B-4K	5B-5K	3K.93C
2	2	2								●
6	2	4							●	
12	1	2							●	

Mixed F.O. + L.V. + Coax

Number of F.O. contacts	Number of L.V. electrical contacts	Number of coax electrical contacts	Series							
			00	0B	0K	2B-2K	3B-3K	4B-4K	5B-5K	3K.93C
1	6	1					●			
1	16	1					●			
2	–	2						●		
2	6	1						●		

Acceptable cable diameter

Cable \varnothing (mm)	Series											
	00	0B	0K	2B	3B	4B	5B	3K.93C	2K	3K	4K	5K
min	0.25	2.5	2.5	1.5	4.1	5.1	9.6	8.3	3.6	3.6	3.6	3.6
max	3.00	4.4	3.0	9.7	11.7	16.0	25.0	16.5	6.5	9.0	13.5	23.5

Selection of electrical contact types

Solder contacts

The conductor bucket of these contacts is machined at an angle to form a cup into which the solder can flow.

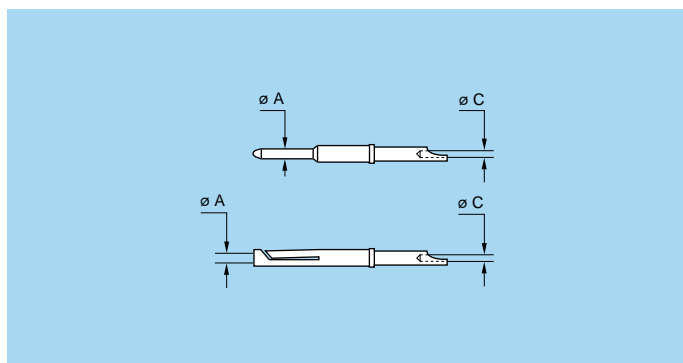

Contact		Conductor			
$\varnothing A$ (mm)	$\varnothing C$ (mm)	Solid		Stranded	
		AWG max.	Section max (mm ²)	AWG max.	Section max (mm ²)
0.7	0.80	22	0.34	22 ¹⁾	0.34
0.9	0.80	22	0.34	22 ¹⁾	0.34
1.3	1.00	20	0.50	20 ¹⁾	0.50
2.0	1.80	14	1.50	16	1.50
4.0	3.70	10	6.00	10	6.00

Note: 1) For a given AWG, the diameter of some stranded conductor designs is larger than the solder cup diameter. Make sure that the maximum conductor diameter is smaller than $\varnothing C$.

Crimp contacts

The crimp contacts are designed to be crimped with the standard four-indent method according to MIL-C-22520F, class 1, type 1.

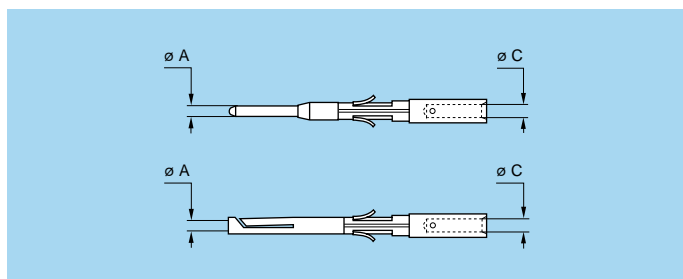

Contact		Conductor stranded				F_r (N)
$\varnothing A$ (mm)	$\varnothing C$ (mm)	AWG stranded		Section (mm ²)		
		min.	max.	min.	max.	
0.7	0.80	26	22 ¹⁾	0.140	0.34	22
0.9	1.10	24	20	0.250	0.50	30
1.3	1.40	20	18	0.500	1.00	40
	1.90 ²⁾	18	14	1.000	1.50	
1.6	1.90	18	14 ¹⁾	1.000	1.50	50
2.0	2.40	16	12 ¹⁾	1.500	2.50	65

Note:

- 1) For a given AWG, the diameter of some stranded conductor designs is larger than the solder cup diameter. Make sure that the maximum conductor diameter is smaller than $\varnothing C$.
- 2) These contacts are special with an oversized crimp bucket and can be used only with the series 3K.93C.

Note: F_r = mean contact retention force in the insulator (according to IEC 60512-8 test 15a). Crimp contacts can also be supplied with a reduced crimp barrel. Please consult factory or our Unipole/Multipole catalog.

A detailed range of conductor dimensions that can be crimped into LEMO contacts is given in the table above. See also the section on tooling (pages 97 to 106).

Coaxial contacts

The type C coaxial contact is removable and fixed in place by clips. Cable attachment is made by crimping. The square form is used to captivate center conductor and hexagonal crimping method for the cable shield. A detailed range of coaxial cable that can be installed into our type C coaxial contact is given in the table below.

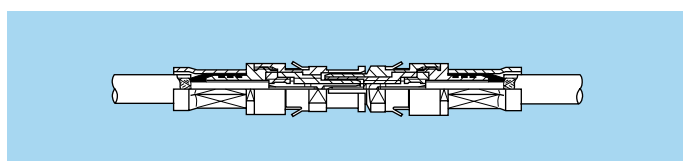

Group	Type
1	RG.174A/U, RG.188A/U, RG.316/U
2	RG.178B/U, RG.196A/U
3	RG.179B/U, RG.187A/U

Part Numbering System

Series

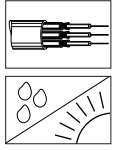

Connectors series and size should be selected according to the type of fibre, single-mode or multi-mode, cable structure and dimensions.

See table on p. 6 (fibre optic connectors production program) and p. 8 (selection of the LEMO fibre optic contacts).

Selection should also consider the environmental requirements such as indoor or outdoor applications etc...

See again table on p. 6 (fibre optic connector production program).

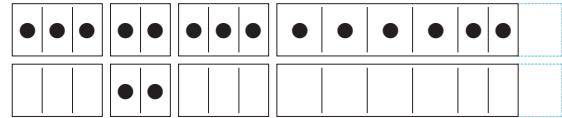

0 0 00 series Single fibre

3 K 3K series Multi fibre or mixed

Type

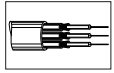

Contact arrangements (type) within a given series can be defined according to the fibre size for single fibre connector or cable design for multi fibre or mixed.

See table on p. 8 (series and contact configuration) and type table in each series.

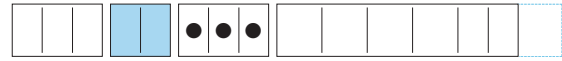

B A 4 Single fibre

0 3 A Multi fibre or mixed

Model

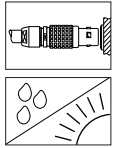

Models within a given series can be selected according to the application and the panel mounting conditions.

See models available in each series.

When available make the right key-way selection.

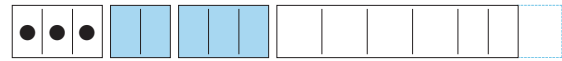

F ●●● Plug

E ●●● Socket

Housing material



The housing material and surface finish depends on the environmental requirements.

See material available in each series.

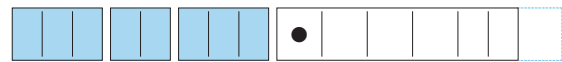

C Chrome-plated brass

Ferrule or insulator material

The ferrule material should be selected according to the availability in each series.

For multi fibre or mixed connector the insulator material is PEEK



Ceramic ferrule **C** Single fibre

PEEK **L** Multi fibre or mixed

Contact

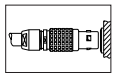

The fibre optic contact should be indicated according to the model.

The electrical contact type can be selected according to the model (male or female), or conductor retention (solder or crimp).

Verify again that contact size matches with the conductor diameter.

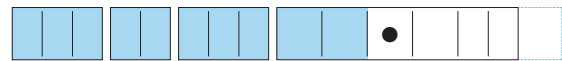

Single fibre **B** Fibre optic plug contact

Mixed **L** Electrical female to solder

Collet

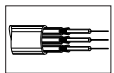

Different clamping systems are proposed for various cable diameters.

See collet type for each series and cable diameter.

Not applicable for sockets E●●.



●● = cable range **T** ●●

Variant

Some variants are available according to special requirements of the application (bend relief collet nut, etc...).

See variant in each series.



Nut for fitting a bend relief **Z**

Supplied with black bend relief **N**



= Environment

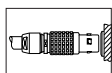

= Application

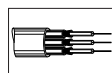

= Cable

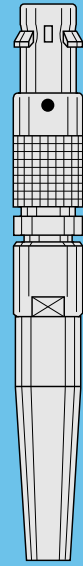
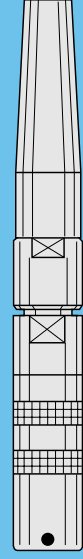

00 SERIES

00 Series

The 00 series connectors are fitted with LEMO F4 type fibre optic contacts.

The main features of this series are as follows:

- Security of the LEMO Push-Pull self-latching system
- Minimum mounting space requirement (high packing density)
- Protection against accidental contamination or damage to the fibre end face because the ferrules do not protrude outside of the connector shell
- The alignment key (G, B) ensures excellent repeatability of performance during frequent matings
- Assembly of the fibre optic contact uses a ceramic ferrule with spherical end face
- Simple and fast polishing ensuring the physical contact of the fibre end face
- The alignment tube can be easily removed in order to clean the fibre end face.

00 Series consists of nine connector models.

The active device housings are designed to accept emitting or receiving components such as LEDs or photodiodes in a TO-18 case.

The plugs and sockets are suitable for use with single fibre cables fitted with single-mode or multi-mode fibres of the following dimensions; 9/125, 50/125, 62.5/125, 100/125 and 100/140 µm.

Interconnections

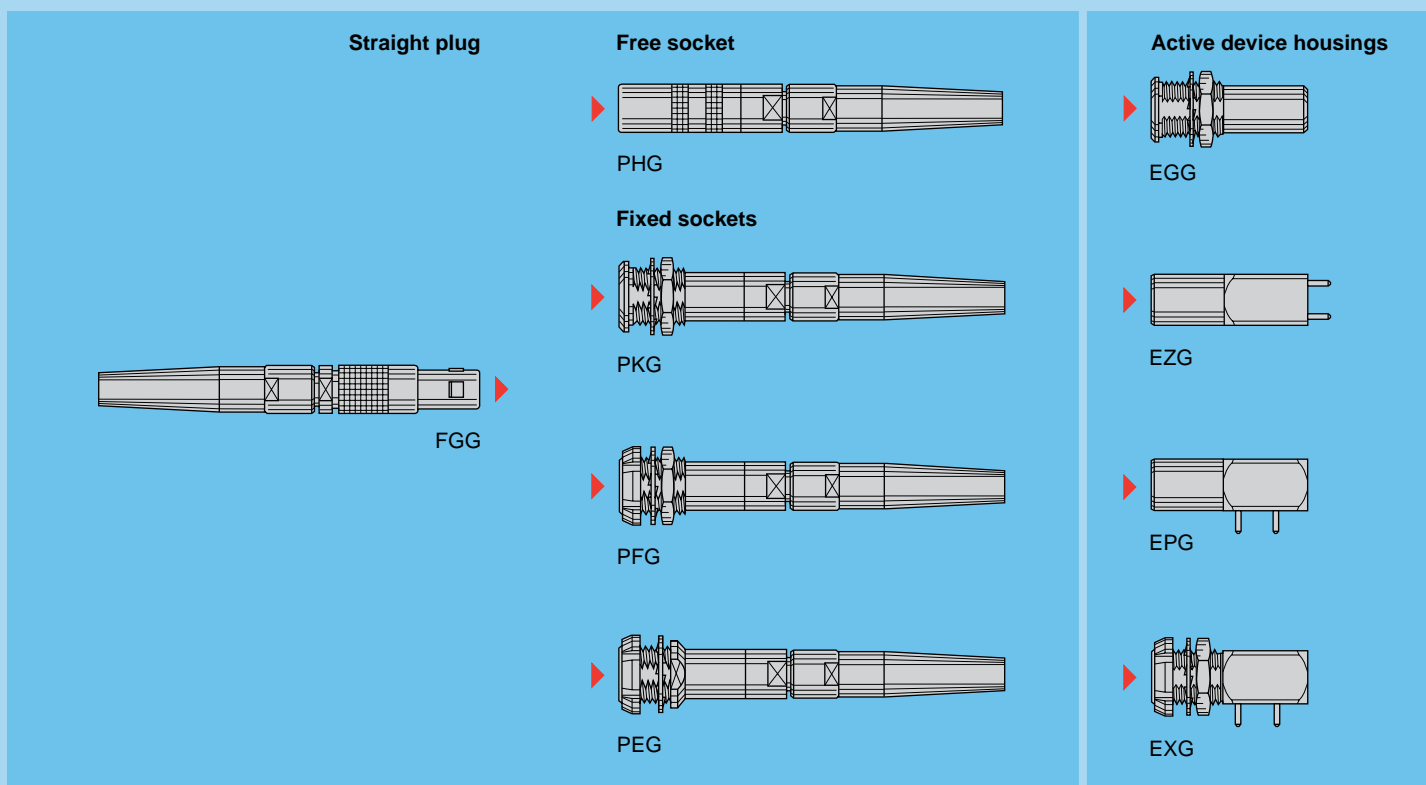

Model Description

EGG Fixed active device housing, nut fixing, key (G) or key (B)

EPG Elbow active device housing (90°) for printed circuit, key (G) or key (B)

EXG Elbow active device housing (90°) for printed circuit, with two nuts, key (G) or key (B), (back panel mounting)

EZG Straight active device housing for printed circuit, key (G) or key (B)

FGG Straight plug, key (G) or key (B), with bend relief

PEG Fixed socket, nut fixing, key (G) or key (B), with bend relief, (back panel mounting)

PFG Fixed socket, with two nuts, key (G) or key (B), with bend relief, (back panel mounting)

PHG Free socket, key (G)

PKG Fixed socket, nut fixing, key (G) or key (B), with bend relief

Part Section Showing Internal Components Connector

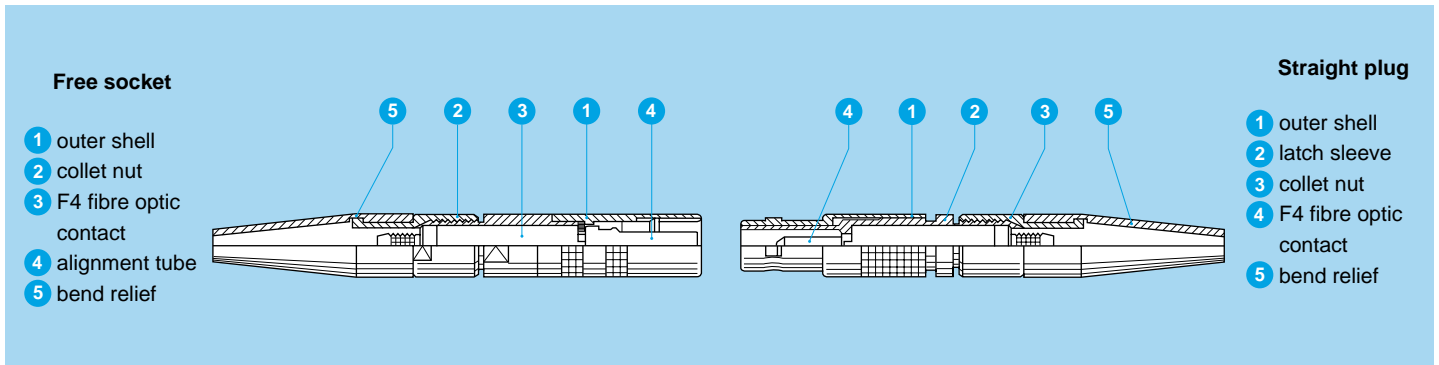

F4 Contact

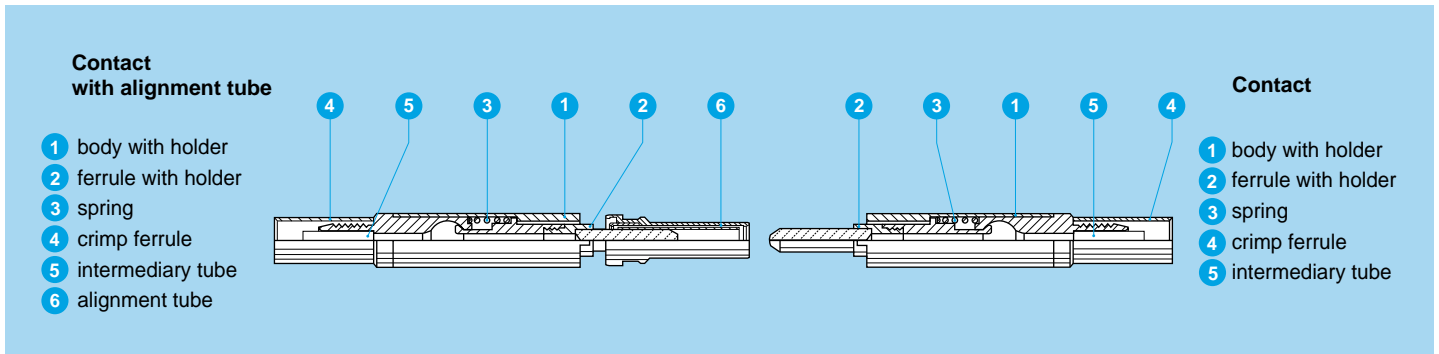

Technical Characteristics

Mechanical and Environmental

Characteristic	Value	Standard
Mating durability	5000 cycles	IEC 61300-02-02
Damp heat steady state	up to 95 % at 60°C	IEC 61300-02-19
High temperature	+80°C	IEC 61300-02-18
Low temperature	-40°C	IEC 61300-02-17
Protection index (mated)	IP 50	IEC 60529
Cable retention	100 N	IEC 61300-02-04

Optical

Characteristic	Value	Standard	Method
Average insertion loss fibre 9/125 µm	0.10 dB	IEC 61300-03-04	Insertion Method B
Average insertion loss fibre 50/125 µm	0.25 dB	IEC 61300-03-04	Insertion Method B
Return loss fibre 9/125 µm (UPC)	≥45 dB	IEC 61300-03-06	Branching Device Met.
Return loss fibre 9/125 µm (Hand polish)	~30 dB	IEC 61300-03-06	Branching Device Met.

Note: Detailed characteristics are presented on pages 109 to 111.

Alignment Key and Polarized Keying Systems

Front view of a socket 	Model	No of keys	Angle	Note
	●●G	1	0°	●
●●B	2	α	60°	○

● First choice alternative ○ Special order alternative

Part Number Example

A different part number is applicable for each of the following product type:

- Plugs or sockets for assembly onto cables
- Active device housings

Straight plug with bend relief

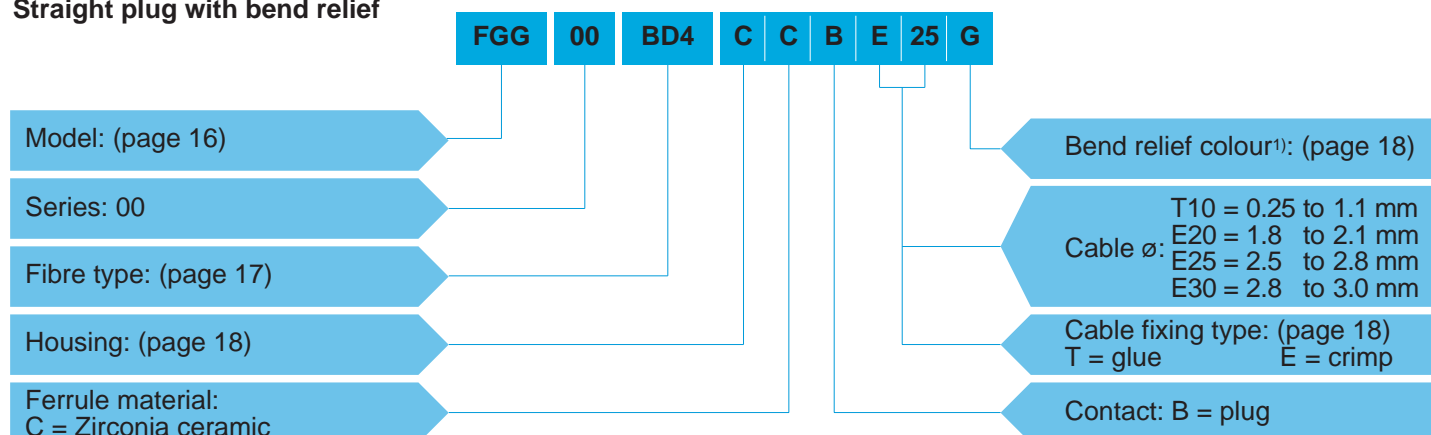

FGG.00.BD4.CCBE25G = Straight plug with key (G), 00 series for single-mode or multi-mode fibres, F4 fibre optic contact, ferrule hole diameter 128 µm, chrome-plated brass housing, zirconia ceramic ferrule, plug type contact, crimp type cable fixing for 2.5 to 2.8 mm diameter cable, and gray bend relief.

Note: ¹⁾ The bend relief sleeve is necessary to the proper function of the connector thus the connector can only be ordered with the appropriate sleeve.

Free socket with bend relief

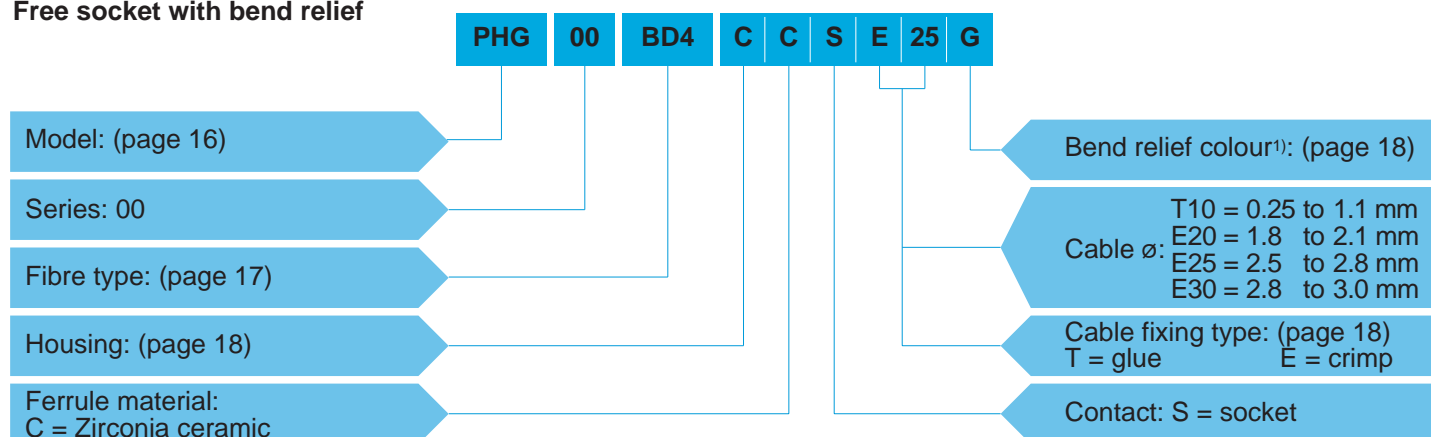

PHG.00.BD4.CCSE25G = Free socket with key (G), 00 series for single-mode or multi-mode fibres, F4 fibre optic contact, ferrule hole diameter 128 µm, chrome-plated brass housing, zirconia ceramic ferrule, socket type contact, crimp type cable fixing for 2.5 to 2.8 mm diameter cable, and gray bend relief.

Note: ¹⁾ The bend relief sleeve is necessary to the proper function of the connector thus the connector can only be ordered with the appropriate sleeve.

Active device housing

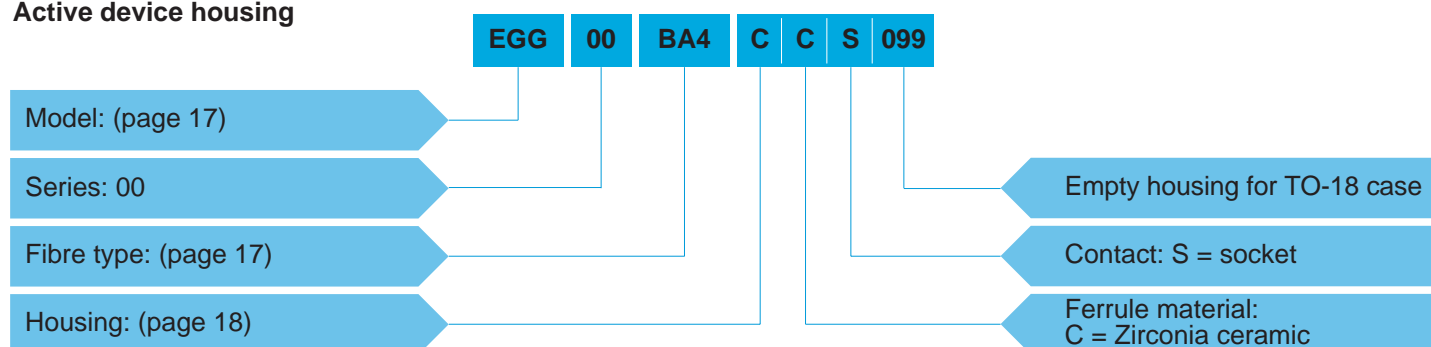

EGG.00.BA4.CCS099 = Straight active device housing, nut fixing with key (G), 00 series, with ferrule for F4 fibre optic contact, assembled with single-mode fibre ø 9/125, chrome-plated brass housing, zirconia ceramic ferrule, socket contact, empty housing for TO-18 case.

Model - Series

FGG.00 Straight plug, key (G) or key (B), with bend relief

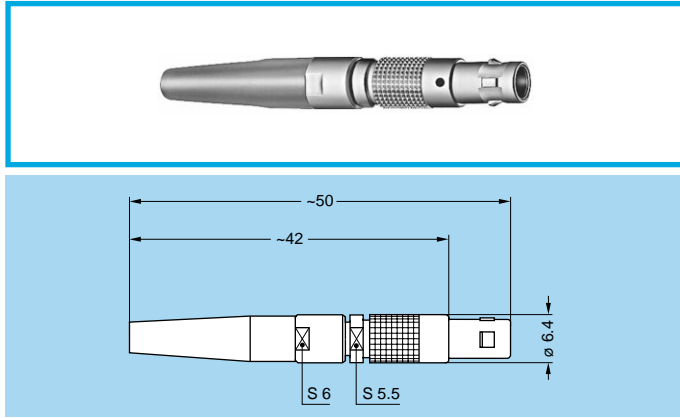

PHG.00 Free socket, key (G) or key (B), with bend relief

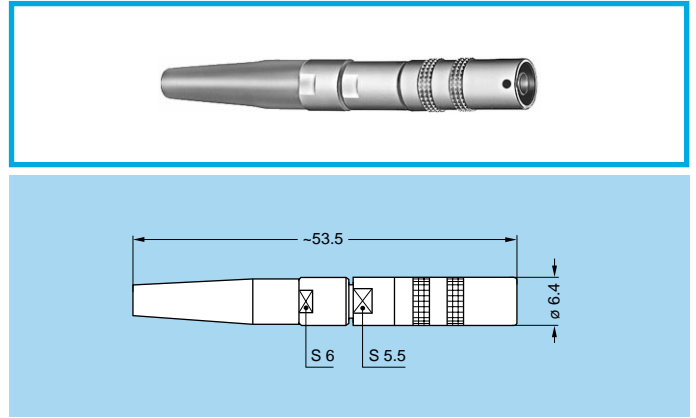

PKG.00 Fixed socket, nut fixing, key (G) or key (B), with bend relief

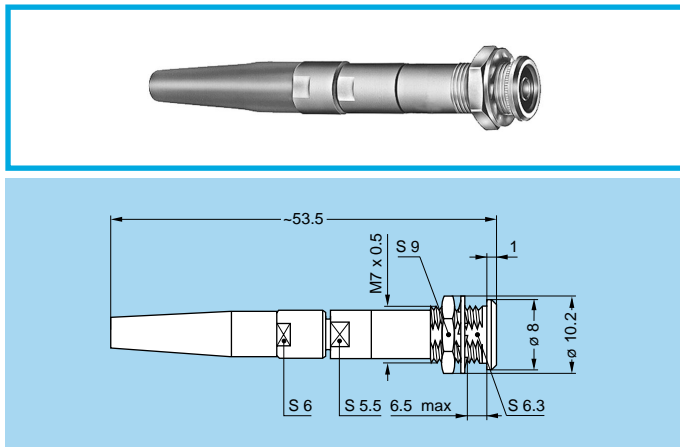

Panel cut-out (page 18)

PEG.00 Fixed socket, nut fixing, key (G) or key (B), with bend relief (back panel mounting)

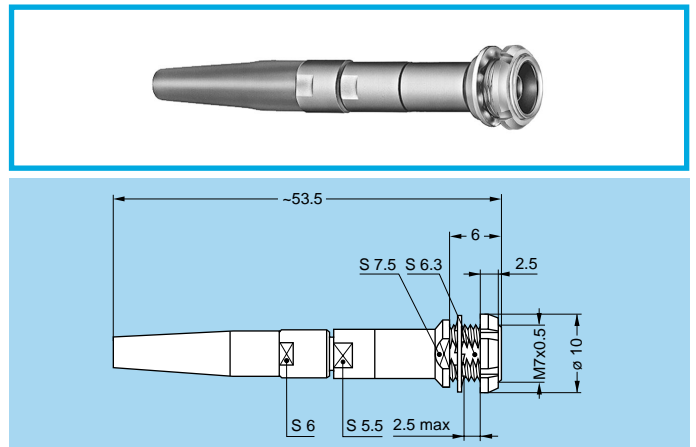

Panel cut-out (page 18)

PFG.00 Fixed socket, with two nuts, key (G) or key (B), with bend relief (back panel mounting)

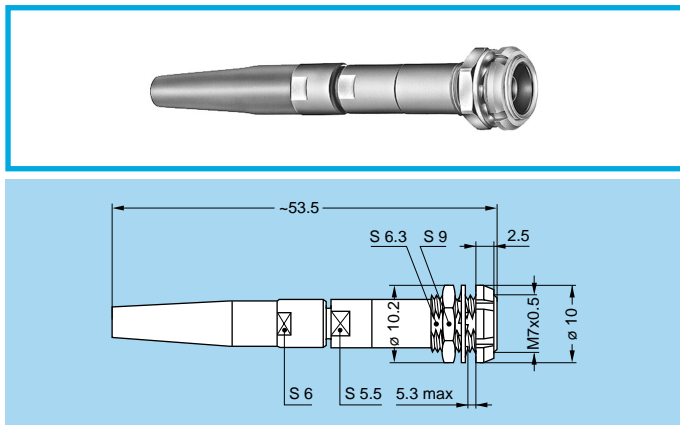

Panel cut-out (page 18)

Note: The overall length dimension is with Desmopan bend relief (see pages 91 and 92).

EGG.00 Fixed active device housing, nut fixing, key (G) or key (B)

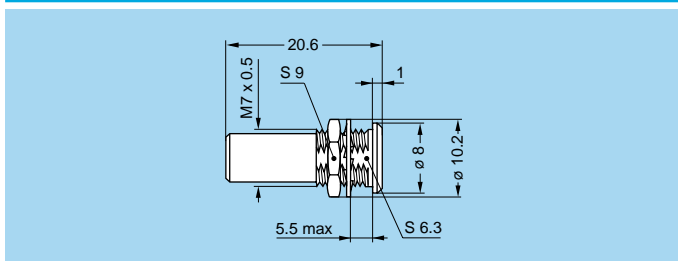
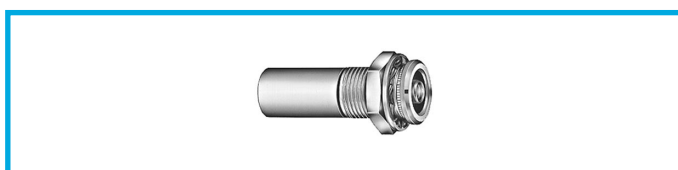

Panel cut-out (page 18)

EZG.00 Straight active device housing for printed circuit, key (G) or key (B)

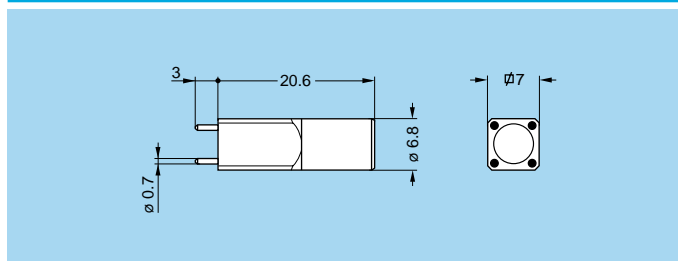
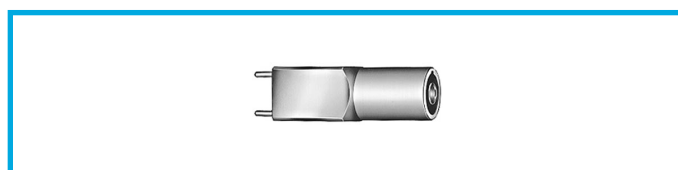

Panel cut-out (page 18)

PCB drilling pattern (page 18)

EPG.00 Elbow active device housing (90°) for printed circuit, key (G) or key (B)

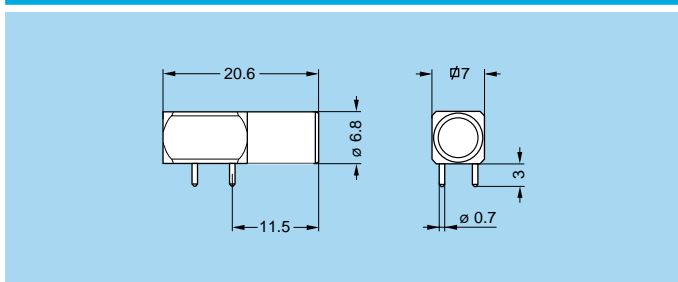
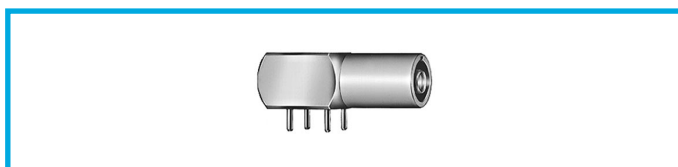

Panel cut-out (page 18)

PCB drilling pattern (page 18)

EXG.00 Elbow active device housing (90°) for printed circuit, with two nuts, key (G) or key (B), (back panel mounting)

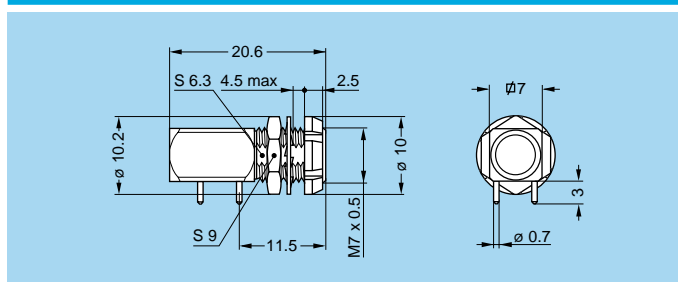
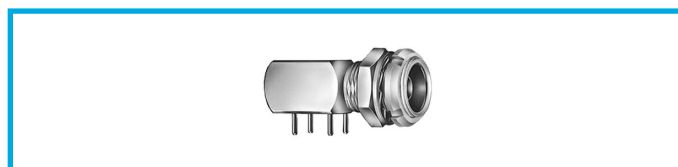

Panel cut-out (page 18)

PCB drilling pattern (page 18)

Note: Upon request active device could be delivered with a specific device of your choice already fitted into. Please consult the factory.

Fibre Type

The choice of the ferrule hole diameter is dependent upon the fibre core/cladding size. LEMO offers a range of ferrule hole diameters to suit the users' specific requirements.

Plug or sockets

The type reference represents the ferrule hole diameter.

Reference	∅ Core/Cladding (µm)	Ferrule hole diameter (µm)	Note 1)
BA4	9/125	125	●
BB4	50/125	126	●
BC4	62.5/125	127	○
BD4	100/125	128	○
FA4	100/140	140	○
FB4		144	●

Note: 1) The BA4 type (ferrule hole 125 µm) is recommended for single-mode fibres. The BB4 type (ferrule hole 126 µm) is commonly used with multi-mode fibres.

Active device housings

The type reference represents the type of fibre used.

Reference	∅ Core/Cladding (µm)	Note
BA4	9/125	●
CA4	50/125	○
DA4	62.5/125	●
EA4	100/125	○
FA4	100/140	●

● First choice alternative ○ Special order alternative

Housing

Ref.	Material	Surface treatment		Note
		Outer shell and collet nut	Latch sleeve and grounding crown	
C	Brass	chrome	nickel	●
N	Brass	nickel	nickel	○
K	Brass	black chrome	nickel	○
T	Stainless steel	without treatment	stainless steel	○

● First choice alternative ○ Special order alternative

Cable Fixing Type

Reference		Cable structure	Cable \varnothing (mm)
Cable fixing Type	Reference \varnothing (mm)		
T	10	Buffer coated fibre	0.25 to 1.1
E	20	Tight jacket cable	1.8 to 2.1
E	25		2.5 to 2.8
E	30		2.8 to 3.0

Bend Relief

Models FGG, PHG, PKG, PEG and PFG are supplied with a bend relief. The reference for the colour of the bend relief is chosen from the table below and it should be stated in the «bend relief» position of the connector part number.

Ref.	Colour	Ref.	Colour	Ref.	Colour	Ref.	Colour	Ref.	Colour
A	blue	G	grey	M	brown	R	red	V	green
B	white	J	yellow	N	black	S	orange		

Tooling

The full range of tools for terminating fibre optic F4 contacts for this 00 series is shown on pages 103 to 106. Consult the factory for the termination instructions.

Panel Cut-Outs

Panel cut-outs

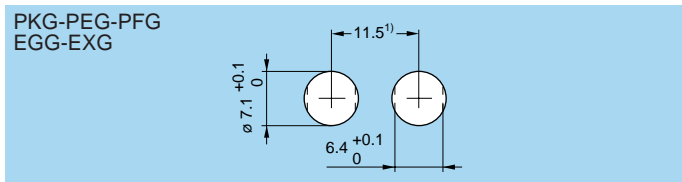

PCB drilling pattern, for the fixing pins

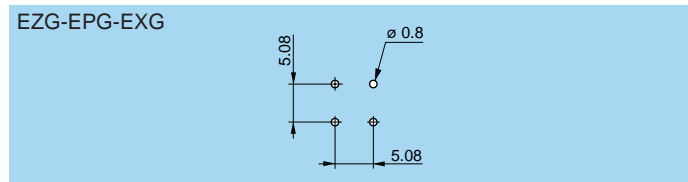

Note: ¹⁾ Minimum distance between two neighbouring components.
Mounting nut torque: **1 Nm**. The value shown above is the maximum torque for each connector type.

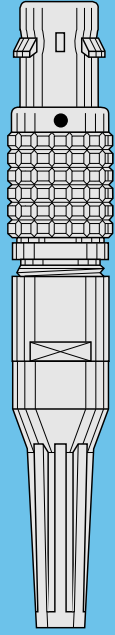
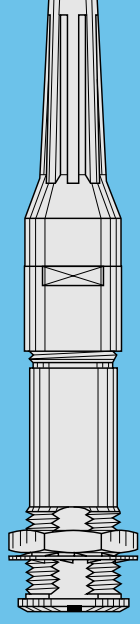

OB SERIES

0B Series

The 0B series connectors are fitted with the LEMO **F3** type fibre optic contacts.

The main features of this series are as follows:

- Security of the LEMO Push-Pull self-latching system
- Minimum mounting space requirement (high packing density)
- Protection against accidental contamination or damage to the fibre end face because the ferrules do not protrude outside the connector shell
- The alignment key (G, A...F) ensures excellent repeatability of performance during frequent matings
- Simple and proven construction of the fibre optic contact with a ceramic or metallic ferrule
- Polishing with special tooling ensuring a minimum spacing of fibres which are not in physical contact.

0B series consists of six connector models.

The active device housings are designed to accept emitting or receiving components such as LEDs or photodiodes in a TO-18 case (without plastic can).

The plugs and straight sockets are suitable for use with single fibre cables fitted with Si/Si or plastic multi-mode fibres with dimensions ranging from 100/140 to 1500 µm external diameter.

Interconnections

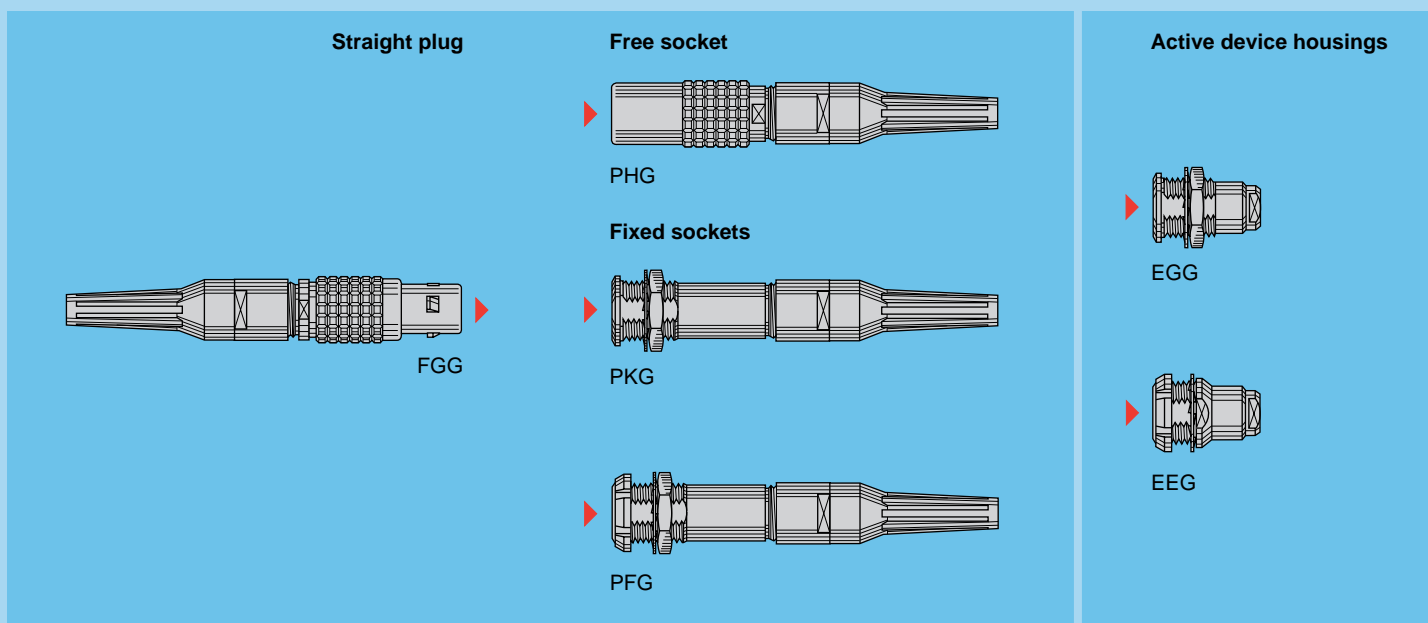

Model description

EEG Fixed active device housing, nut fixing, key (G) or keys (A...F), (back panel mounting)

EGG Fixed active device housing, nut fixing, key (G) or keys (A...F)

FGG Straight plug, key (G) or keys (A...F), with bend relief

PFG Fixed socket, with two nuts, key (G) or keys (A...F), with bend relief, (back panel mounting)

PHG Free socket, key (G) or keys (A...F), with bend relief

PKG Fixed socket, nut fixing, key (G) or keys (A...F), with bend relief

Part Section Showing Internal Components Connector

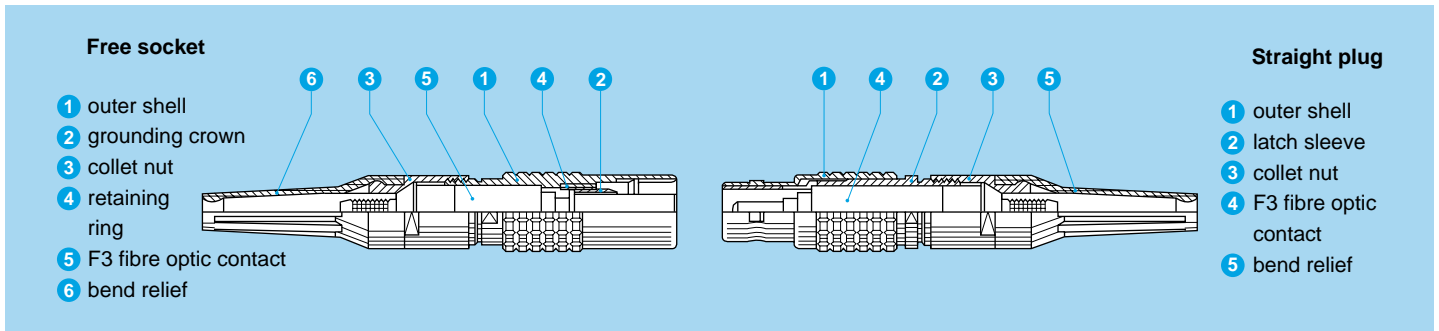

F3 Contact

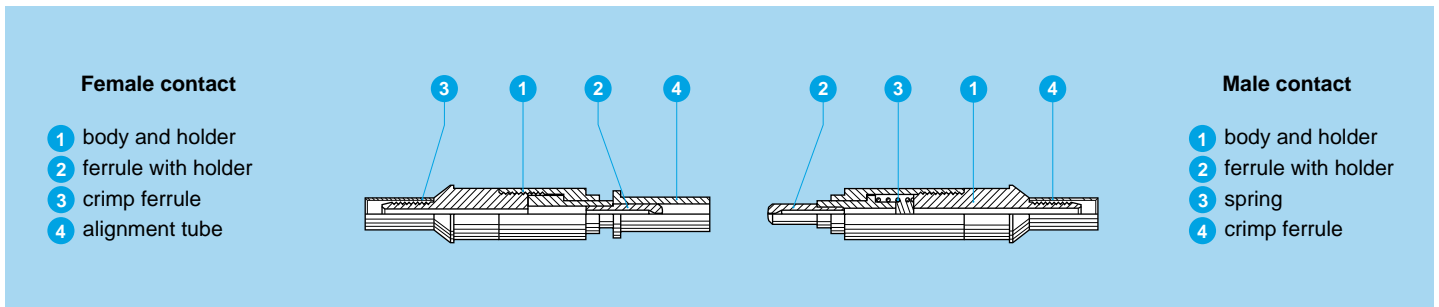

Technical Characteristics

Mechanical and Environmental

Characteristic	Value	Standard
Mating durability	1000 to 5000 cycles	IEC 61300-02-02
Damp heat steady state	up to 95 % at 60°C	IEC 61300-02-19
High temperature	+80°C	IEC 61300-02-18
Low temperature	-40°C	IEC 61300-02-17
Protection index (mated)	IP 50	IEC 60529
Cable retention	100 N	IEC 61300-02-04

Optical

Characteristic	Value	Standard	Method
Average insertion loss fibre 200/230 µm	1.13 dB	IEC 61300-03-04	Insertion Method B

Note: Detailed characteristics are presented on pages 109 to 111.

Alignment Key and Polarized Keying Systems

Front view of a socket 	Model	No of keys	Angles	Note
	••G	1	α	0°
••A	2	30°		●
••B	2	60°		●
••C	2	90°		●
••D	2	β	135°	○
••E	2		145°	○
••F	2		155°	○

● First choice alternative ○ Special order alternative

Part Number Example

A different part number structure is applicable for each of the following product types:

- Plugs or sockets for assembly onto cables
- Active device housings

Straight plug with bend relief

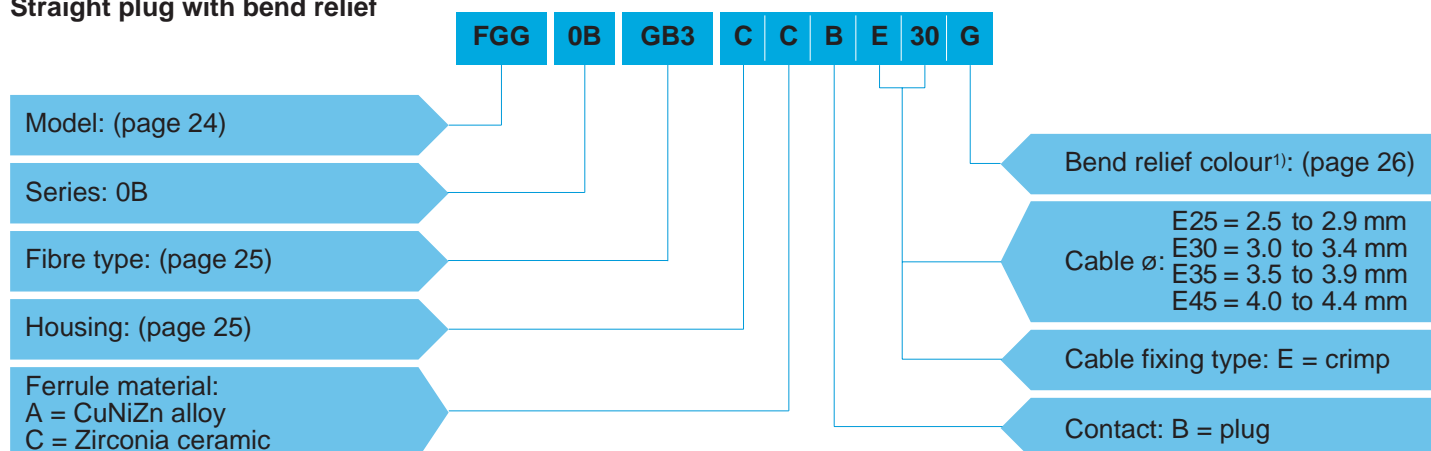

FGG.0B.GB3.CCBE30G = Straight plug with key (G), 0B series, F3 fibre optic contact, ferrule hole diameter 235 μ m, chrome-plated brass housing, zirconia ceramic ferrule, plug type contact, crimp type cable fixing for 3.0 to 3.4 mm diameter cable, and gray bend relief.

Note: ¹⁾ The bend relief sleeve is necessary to the proper function of the connector thus the connector can only be ordered with the appropriate sleeve.

Free socket with bend relief

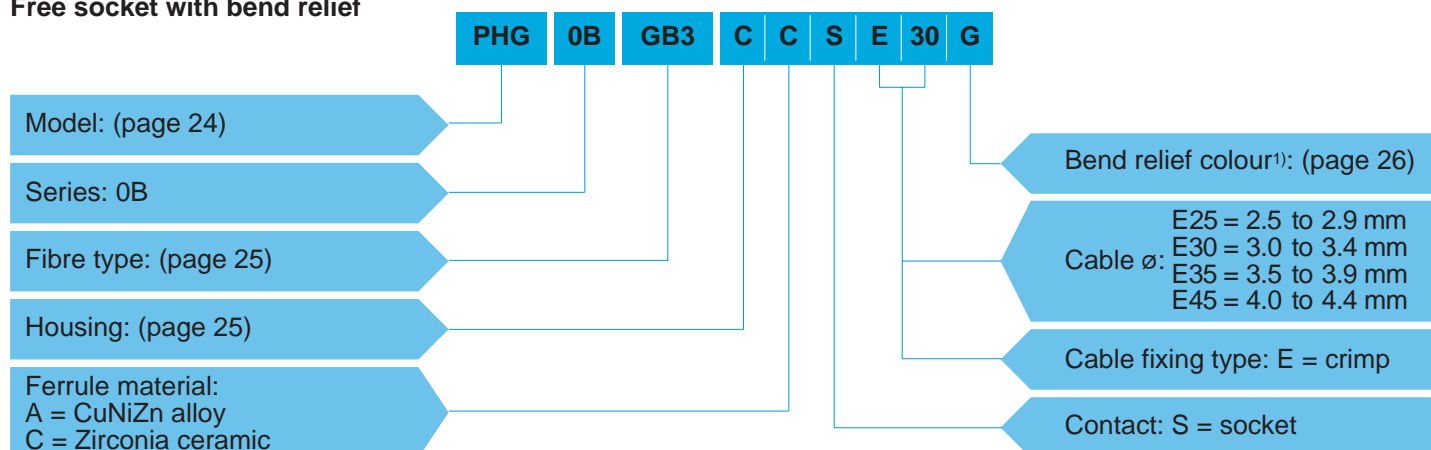

PHG.0B.GB3.CCSE30G = Free socket with key (G), 0B series, F3 fibre optic contact, ferrule hole diameter 235 μ m, chrome-plated brass housing, zirconia ceramic ferrule, socket type contact, crimp type cable fixing for 3.0 to 3.4 mm diameter cable, and gray bend relief.

Note: ¹⁾ The bend relief sleeve is necessary to the proper function of the connector thus the connector can only be ordered with the appropriate sleeve.

Active device housings

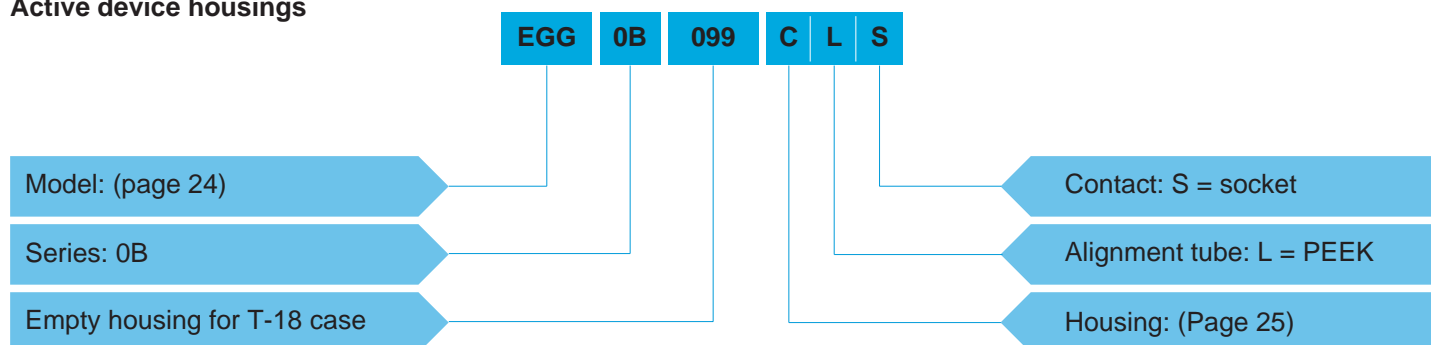

EGG.0B.099.CLS = Fixed active device housing, nut fixing, with key (G), 0B series, empty housing for TO-18 case, chrome-plated brass housing, PEEK alignment tube, socket contact.

Model - Series

FGG.0B Straight plug, key (G) or keys (A...F), with bend relief

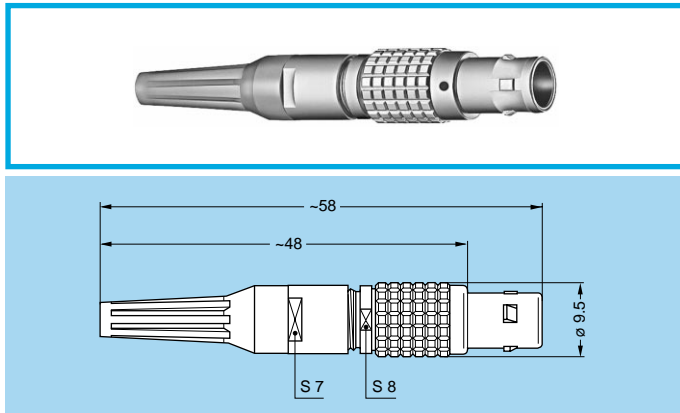

PHG.0B Free socket, key (G) or keys (A...F), with bend relief

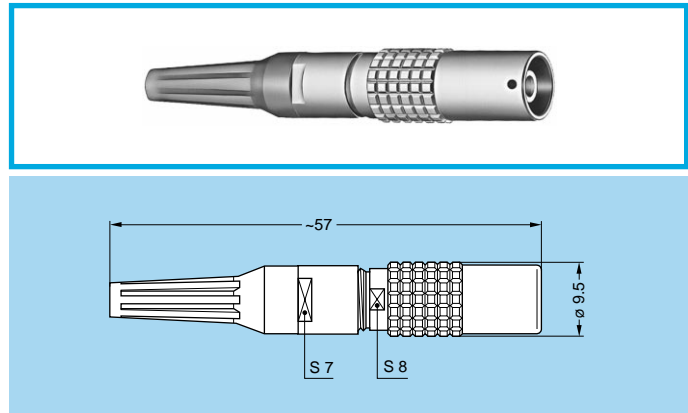

PKG.0B Fixed socket, nut fixing, key (G) or keys (A...F), with bend relief

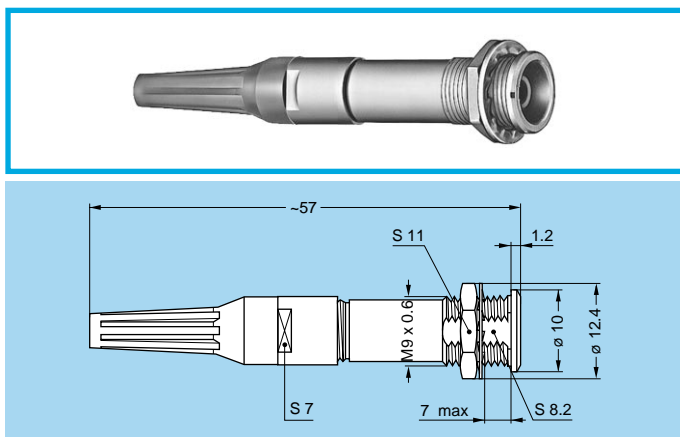

PFG.0B Fixed socket, with two nuts, key (G) or keys (A...F), with bend relief, (back panel mounting)

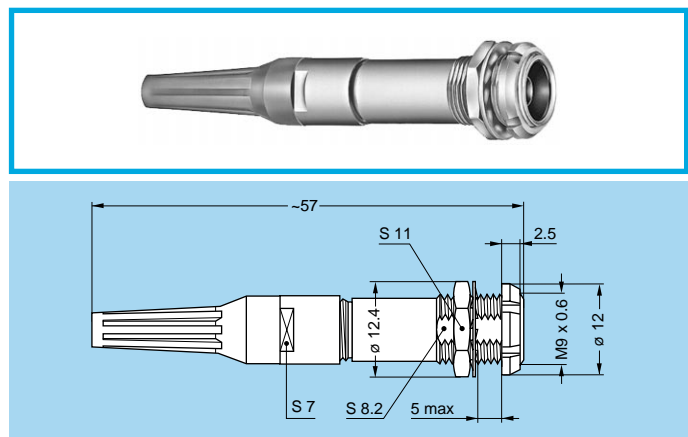

Panel cut-out (page 26)

Panel cut-out (page 26)

Note: The overall length dimension is with Desmopan bend relief (see pages 91 and 92).

EGG.0B Fixed active device housing, nut fixing, key (G) or keys (A...F)

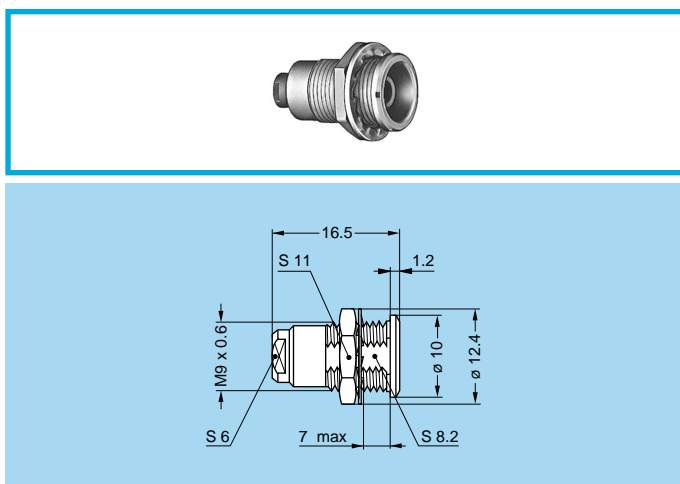

EEG.0B Fixed active device housing, nut fixing, key (G) or keys (A...F), (back panel mounting)

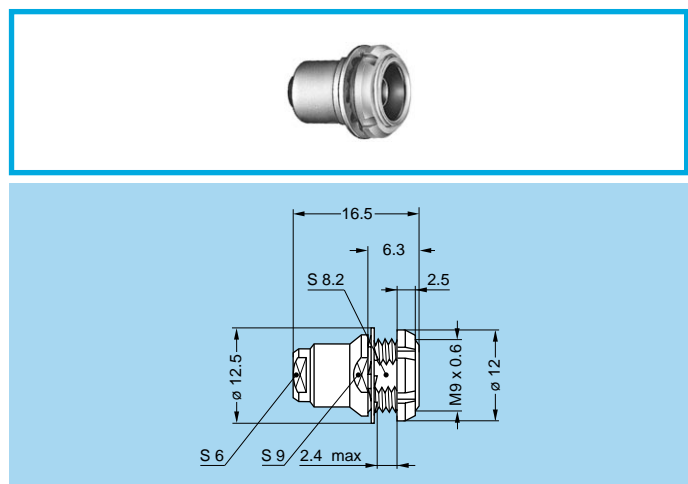

Panel cut-out (page 26)

Panel cut-out (page 26)

Fibre Type

The choice of the ferrule hole diameter is dependent upon the fibre cladding size. LEMO offers a range of ferrule hole diameters to suit the users' specific requirements.

Reference	Core/cladding ø (µm)	Ferrule hole ø (µm)	Ferrule material	Material ref.	Fibre type	Note
FB3	100/140	144	Ceramic	C	Silica	●
GA3	200/230	230	Ceramic	C	HCS	○
GB3	200/230	235	Ceramic	C	HCS	●
HA3	300/330	330	Ceramic	C	HCS	○
HB3	300/330	335	Ceramic	C	HCS	●
JA3	400/430	430	Metal	A	HCS	○
JB3	400/430	435	Metal	A	HCS	●
KA3	600/630	630	Metal	A	HCS	○
KB3	600/630	640	Metal	A	HCS	●
LA3	800/830	830	Metal	A	HCS	○
LB3	800/830	845	Metal	A	HCS	●
MA3	1000/1035	1035	Metal	A	HCS	○
MB3	1000/1035	1050	Metal	A	HCS	●
NA3	500	500	Metal	A	Polymer	○
NB3	500	550	Metal	A	Polymer	●
PA3	750	750	Metal	A	Polymer	○
PB3	750	825	Metal	A	Polymer	●
RA3	1000	1000	Metal	A	Polymer	○
RB3	1000	1100	Metal	A	Polymer	●
RK3	1400	1430	Metal	A	Polymer	●
SA3	1500	1500	Metal	A	Polymer	○
SB3	1500	1650	Metal	A	Polymer	●
TA3	200/380	380	Metal	A	PCS	○
TB3	200/380	410	Metal	A	PCS	●
VA3	300/440	440	Metal	A	PCS	○
VB3	300/440	475	Metal	A	PCS	●
WA3	600/750	750	Metal	A	PCS	●
WB3	600/750	810	Metal	A	PCS	●

● First choice alternative
○ Special order alternative

Housing

Ref.	Material	Surface treatment		Note
		Outer shell and collet nut	Latching sleeve and grounding crown	
C	Brass	chrome	nickel	●
N	Brass	nickel	nickel	○
K	Brass	black chrome	nickel	○
T	Stainless steel	without treatment	stainless steel	○

● First choice alternative ○ Special order alternative

▶ Bend Relief

Models FGG, PHG, PKG and PFG are supplied with a bend relief. The reference for the colour of the bend relief is chosen from the table below and it should be stated in the «bend relief» position of the connector part number.

Ref.	Colour
A	blue
B	white

Ref.	Colour
G	grey
J	yellow

Ref.	Colour
M	brown
N	black

Ref.	Colour
R	red
S	orange

Ref.	Colour
V	green

▶ Tooling

The full range of tools for terminating fibre optic F3 contacts of this 0B series is shown on pages 104 to 106. Consult the factory for the termination instructions.

Panel Cut-Outs

Panel cut-outs

PKG-PFG-EGG-EEG

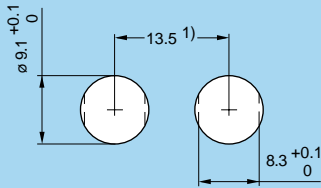

Note: ¹⁾ Minimum distance between two neighbouring components.
Mounting nut torque: **2.5 Nm**.
The value shown above is the maximum torque for each connector type.

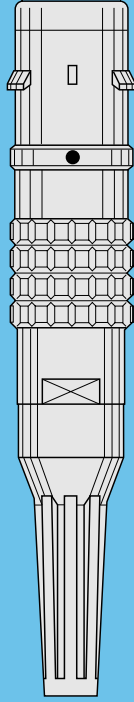
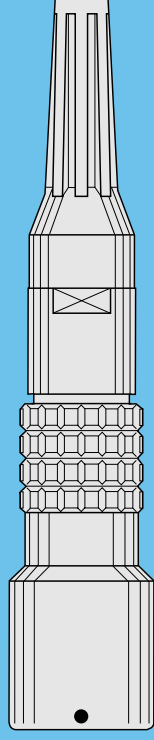

OK SERIES

OK Series

The LEMO OK series fibre optic connector is ideal for use in harsh environments. The mated connectors are sealed to IP 66-IP 68 (underwater immersion to 1.5 m depth). It uses the standard LEMO **F2** fibre optic contact which has undergone extensive mechanical, optical and environmental testing and has seen service in many critical applications such as outside broadcast television.

Based upon the proven LEMO Push-Pull self-latching system, this new fibre optic connector features:

- Sealed to IP 66-IP 68 for environmental protection
- Highly compact design for space saving
- Very low insertion loss for both multi-mode and single-mode fibres
- Low back reflection performance
- The alignment key (G, A...F) ensures excellent repeatability of performance during frequent matings
- Fully floating ceramic ferrule with spherical end face
- Simple and fast polishing ensuring the physical contact of the fibre end face
- The alignment tube can be easily removed in order to clean the fibre end face
- Field termination possible
- Excellent shock and vibration resistance.

Interconnections

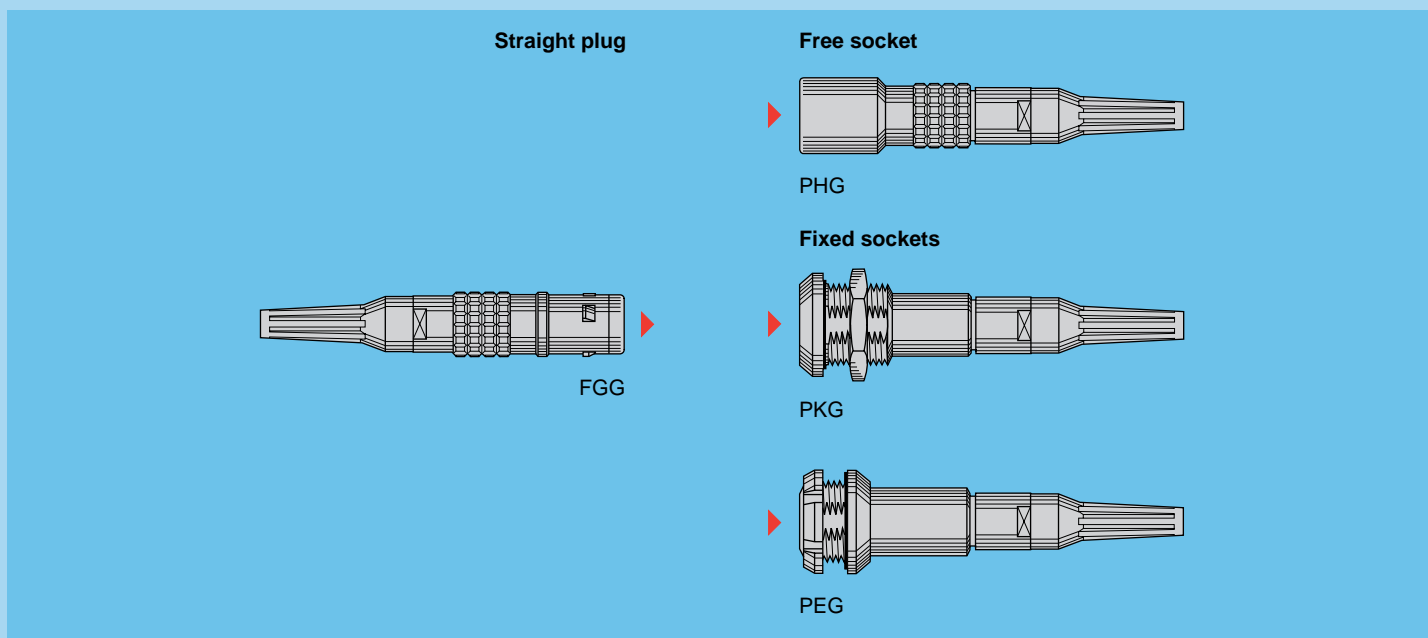

Model Description

- FGG** Straight plug, key (G) or keys (A...F) and cable adapter, with bend relief
- PEG** Fixed socket, nut fixing, key (G) or keys (A...F) and cable adapter, with bend relief (back panel mounting)

- PHG** Free socket, key (G) or keys (A...F) and cable adapter, with bend relief

- PKG** Fixed socket, nut fixing, key (G) or keys (A...F) and cable adapter, with bend relief

Part Section Showing Internal Components Connector

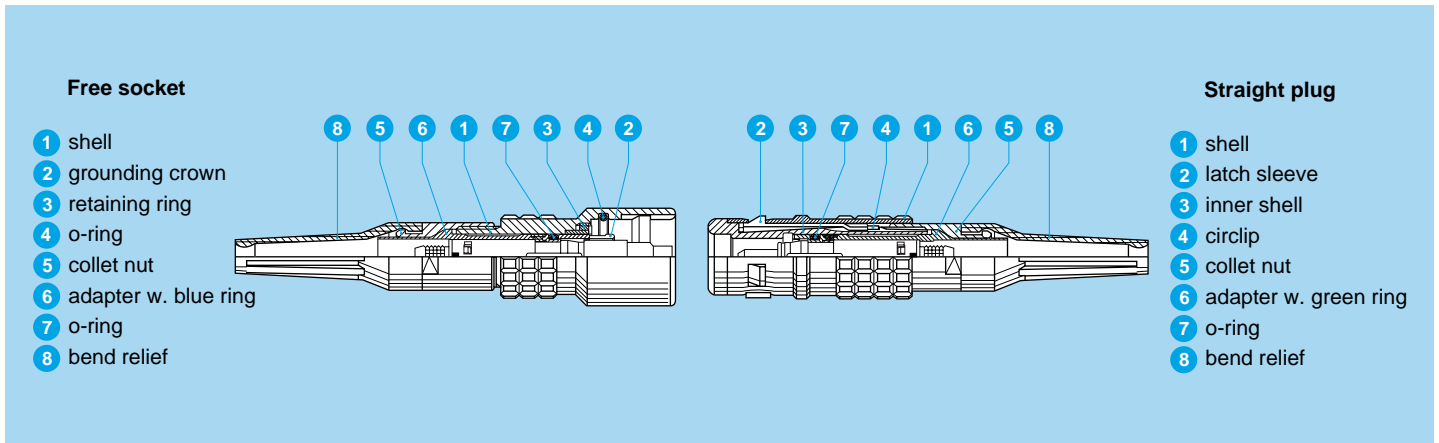

F2 Contact

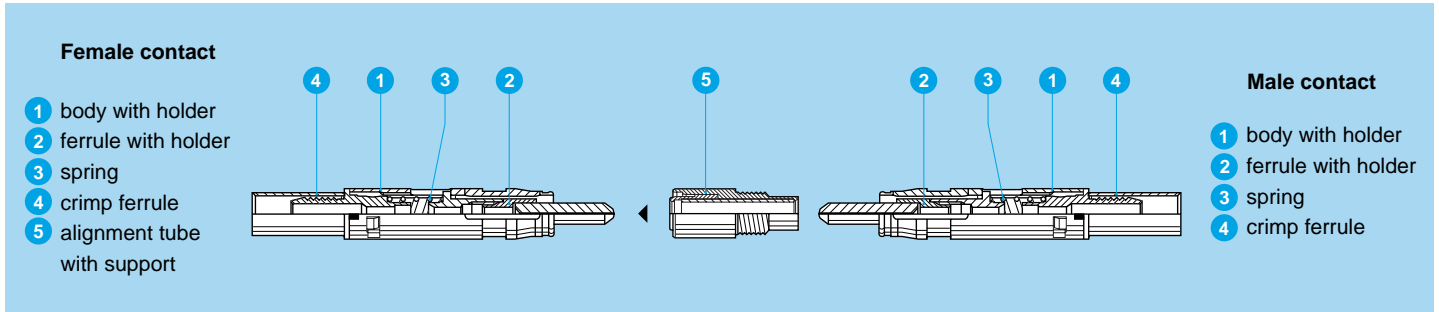

Technical Characteristics

Mechanical and Environmental

Characteristic	Value	Standard
Mating durability	5000 cycles	IEC 61300-02-02
Damp heat steady state	up to 95 % at 60°C	IEC 61300-02-19
High temperature	+80°C	IEC 61300-02-18
Low temperature	-40°C	IEC 61300-02-17
Protection index (mated)	IP 66-IP 68	IEC 60529
Cable retention	100 N	IEC 61300-02-04
Impact (Method A)	1 m onto concrete floor	IEC 61300-02-12
Shock (3 cycles in 2 directions)	100 g, 10-50 ms; 20 g 6-9 ms	IEC 61300-02-09
Vibration (7 cycles)	Diagram 2 page 111	IEC 61300-02-01

Optical

Characteristic	Value	Standard	Method
Average insertion loss fibre 9/125 µm	0.10 dB	IEC 61300-03-04	Insertion Method B
Average insertion loss fibre 50/125 µm	0.25 dB	IEC 61300-03-04	Insertion Method B
Return loss fibre 9/125 µm (UPC)	≥45 dB	IEC 61300-03-06	Branching Device Met.
Return loss fibre 9/125 µm (Hand polish)	~30 dB	IEC 61300-03-06	Branching Device Met.

Note: Detailed characteristics are presented on pages 109 to 111.

Alignment Key and Polarized Keying Systems

Front view of a socket

Model	No of keys	Angles		Note
●●G	1	α	0°	●
●●A	2		30°	●
●●B	2		45°	●
●●C	2		60°	●
●●D	2	γ	95°	○
●●E	2	β	120°	○
●●F	2		145°	○

● First choice alternative ○ Special order alternative

Part Number Example

Straight plug with bend relief

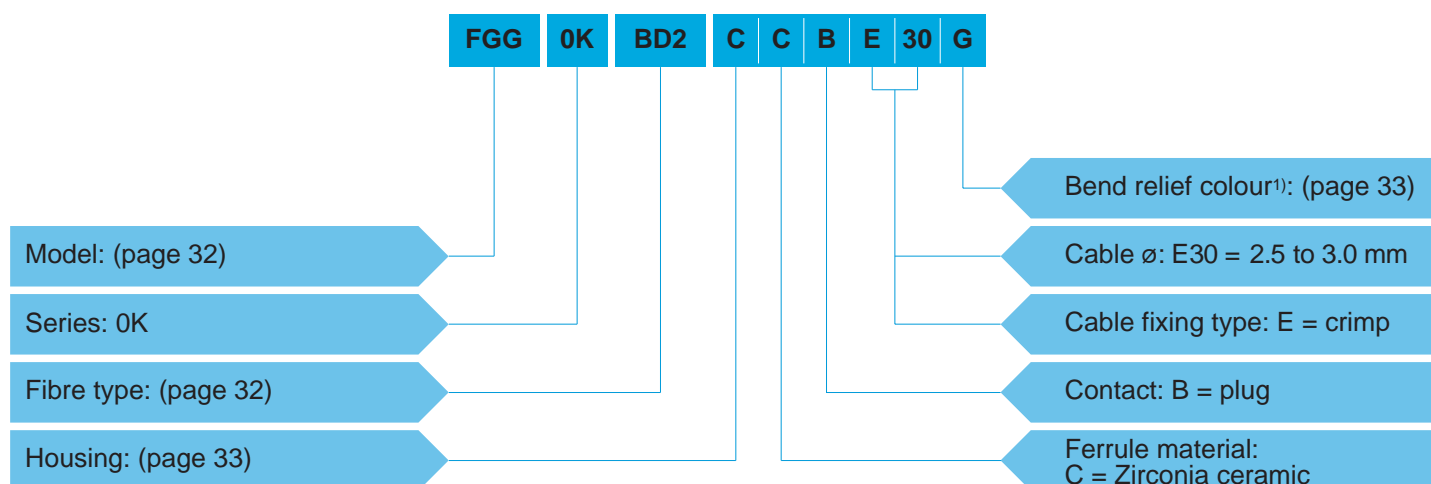

FGG.0K.BD2.CCBE30G = Straight plug with key (G), 0K series, F2 fibre optic contact, ferrule hole ø 128 µm, chrome-plated brass housing, zirconia ceramic ferrule, plug type contact, crimp type cable fixing for 2.5 to 3.0 mm diameter cable, and gray bend relief.

Note: ¹⁾ The bend relief sleeve is necessary to the proper function of the connector thus the connector can only be ordered with the appropriate sleeve.

Free socket

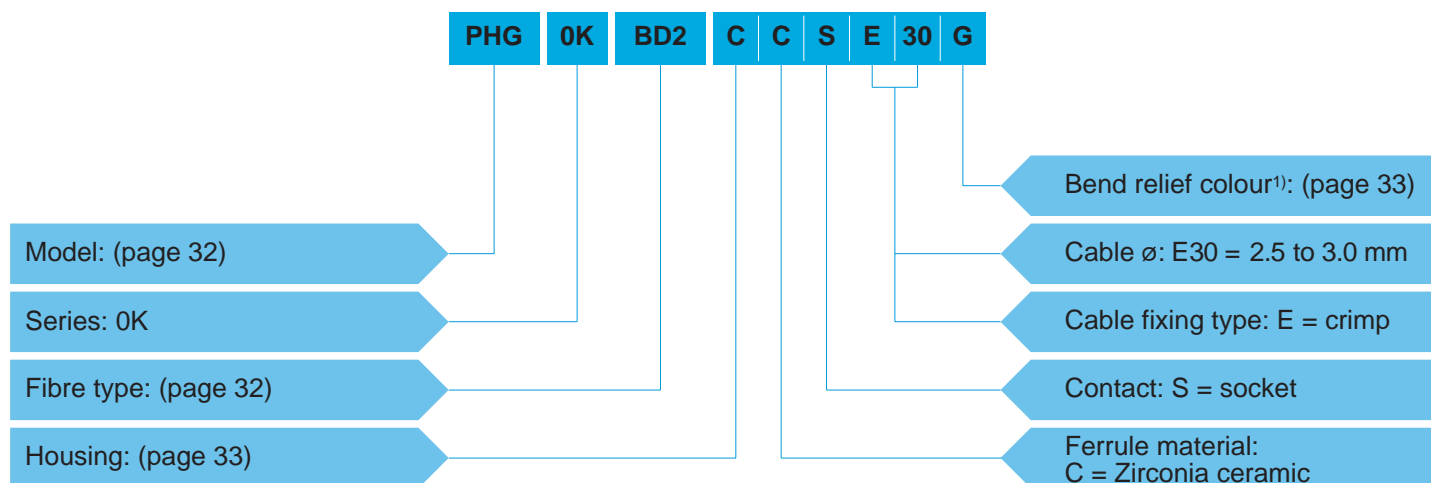

PHG.0K.BD2.CCSE30G = Free socket with key (G), 0K series, F2 fibre optic contact, ferrule hole ø 128 µm, chrome-plated brass housing, zirconia ceramic ferrule, socket type contact, crimp type cable fixing for 2.5 to 3.0 mm diameter cable, and gray bend relief.

Note: ¹⁾ The bend relief sleeve is necessary to the proper function of the connector thus the connector can only be ordered with the appropriate sleeve.

Models - Series

FGG.0K Straight plug, key (G) or keys (A...F) and cable adapter, with bend relief

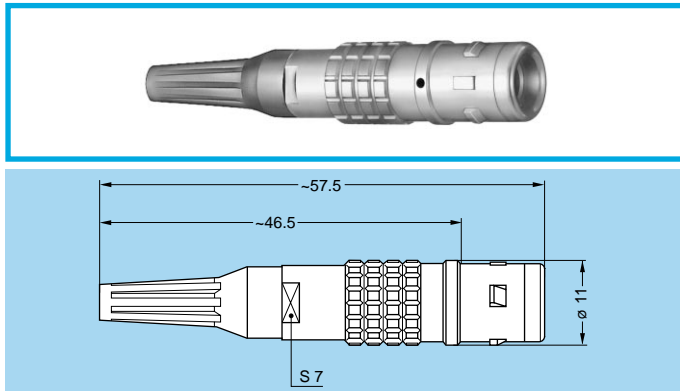

PHG.0K Free socket, key (G) or keys (A...F) and cable adapter, with bend relief

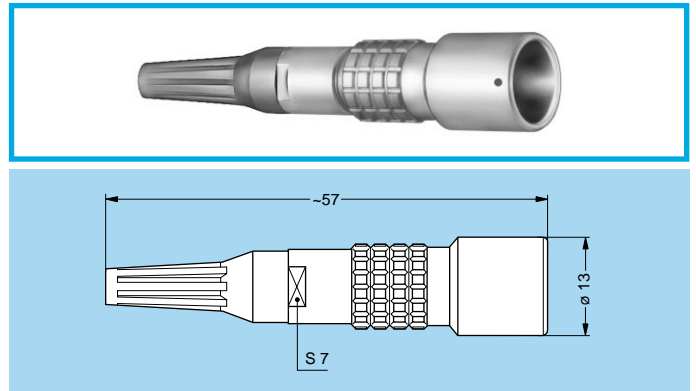

PKG.0K Fixed socket, nut fixing, key (G) or keys (A...F) and cable adapter, with bend relief

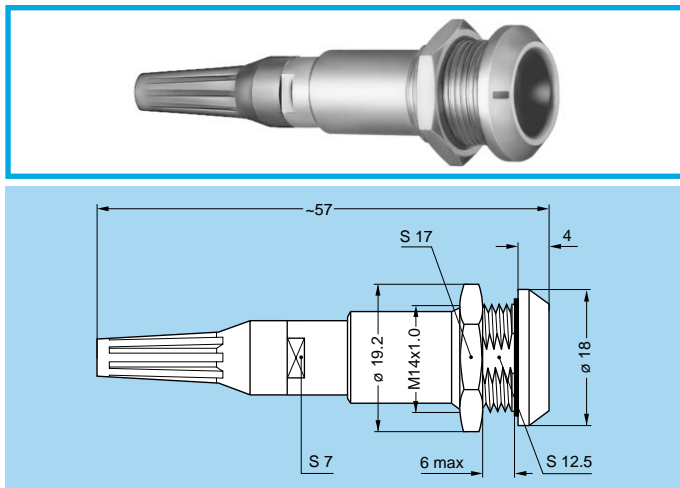

PEG.0K Fixed socket, nut fixing, key (G) or keys (A...F) and cable adapter, with bend relief (back panel mounting)

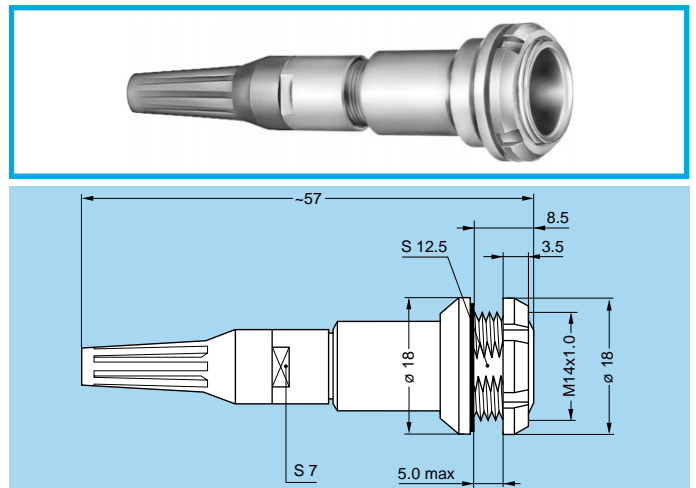

Panel cut-out (page 33)

Panel cut-out (page 33)

Note: The overall length dimension is with Desmopan bend relief (see pages 91 and 92).

Fibre Type

The choice of the ferrule hole diameter is dependent upon the fibre core/cladding size. LEMO offers a range of ferrule hole diameters to suit the users' specific requirements.

Plug or sockets

The type reference represents the ferrule hole diameter.

Reference	ø Core/Cladding (µm)	Ferrule hole diameter (µm)	Note 1)
BA2	9/125	125	●
BB2	50/125	126	●
BC2	62.5/125	127	○
BD2	100/125	128	○
FA2	100/140	140	○
FB2		144	●

Note:

1) The BA2 type (ferrule hole 125 µm) is recommended for single-mode fibres. The BB2 type (ferrule hole 126 µm) is commonly used with multi-mode fibres.

● First choice alternative ○ Special order alternative

▶ □ □ □ □ □ □ □ □ Housing

Ref.	Material	Surface treatment		Note
		Outer shell and collet nut	Latching sleeve and grounding crown	
C	Brass	chrome	nickel	●
N	Brass	nickel	nickel	○
K	Brass	black chrome	nickel	○
T	Stainless steel	without treatment	stainless steel	○

● First choice alternative ○ Special order alternative

▶ □ □ □ □ □ □ □ □ Bend Relief

All models are supplied with a bend relief. The reference for the colour of the bend relief is chosen from the table below and it should be stated in the «bend relief» position of the connector part number.

Ref.	Colour
A	blue
B	white

Ref.	Colour
G	grey
J	yellow

Ref.	Colour
M	brown
N	black

Ref.	Colour
R	red
S	orange

Ref.	Colour
V	green

▶ □ □ □ □ □ □ Tooling

The full range of tools for terminating fibre optic F2 contacts of this OK series is shown on pages 103 to 106. Consult the factory for the termination instructions.

Panel Cut-Outs

Panel cut-outs

PEG-PKG

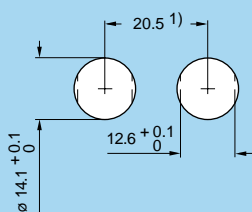

Note: ¹⁾ Minimum distance between two neighbouring components.
 Mounting nut torque: **5 Nm**.
 The value shown above is the maximum torque for each connector type.

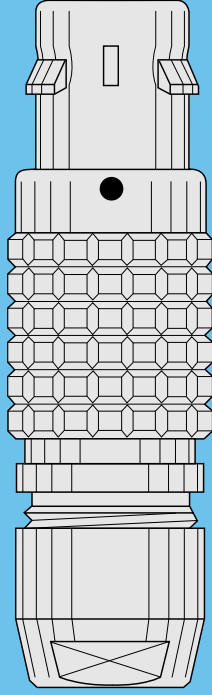
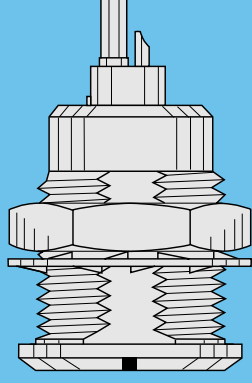

2B-5B SERIES

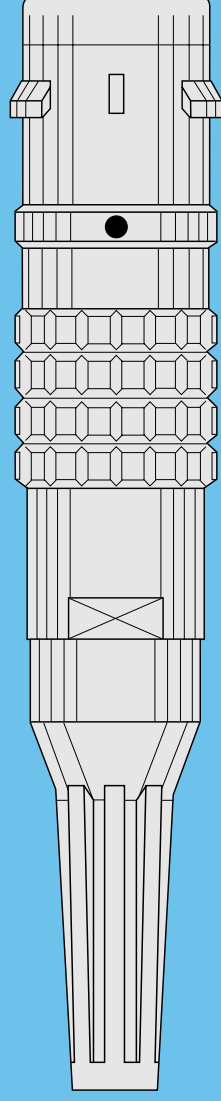
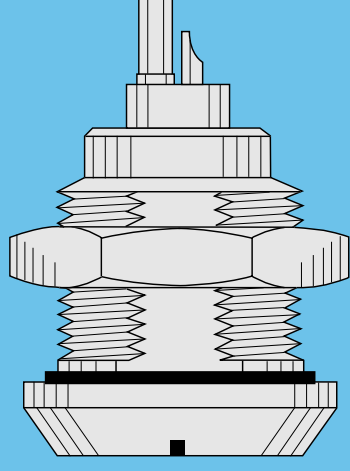

2K-5K SERIES

2B-5B Series

The 2B-5B connectors have been designed to work with the LEMO **F1** or **F2** type fibre optic contacts.

The main features of these series are as follows:

- Security of the LEMO Push-Pull self-latching system
- Protection against accidental contamination or damage to the fibre end face because the ferrules are recessed within the connector shell
- The alignment key (G, A...L, Y and R) ensures excellent repeatability of performance during frequent matings
- A choice of configurations of multi fibre or mixed optical/electrical contacts.

The 2B-5B series consist of fifteen models. The possible outer cable diameters range from 1.5 to 25 mm.

Depending upon the type of fibre optic contact chosen, the connectors can accommodate single-mode fibres in Si/Si 9/125 or multi-mode fibres in silica or plastic with an external diameter up to 1500 µm.

Interconnections

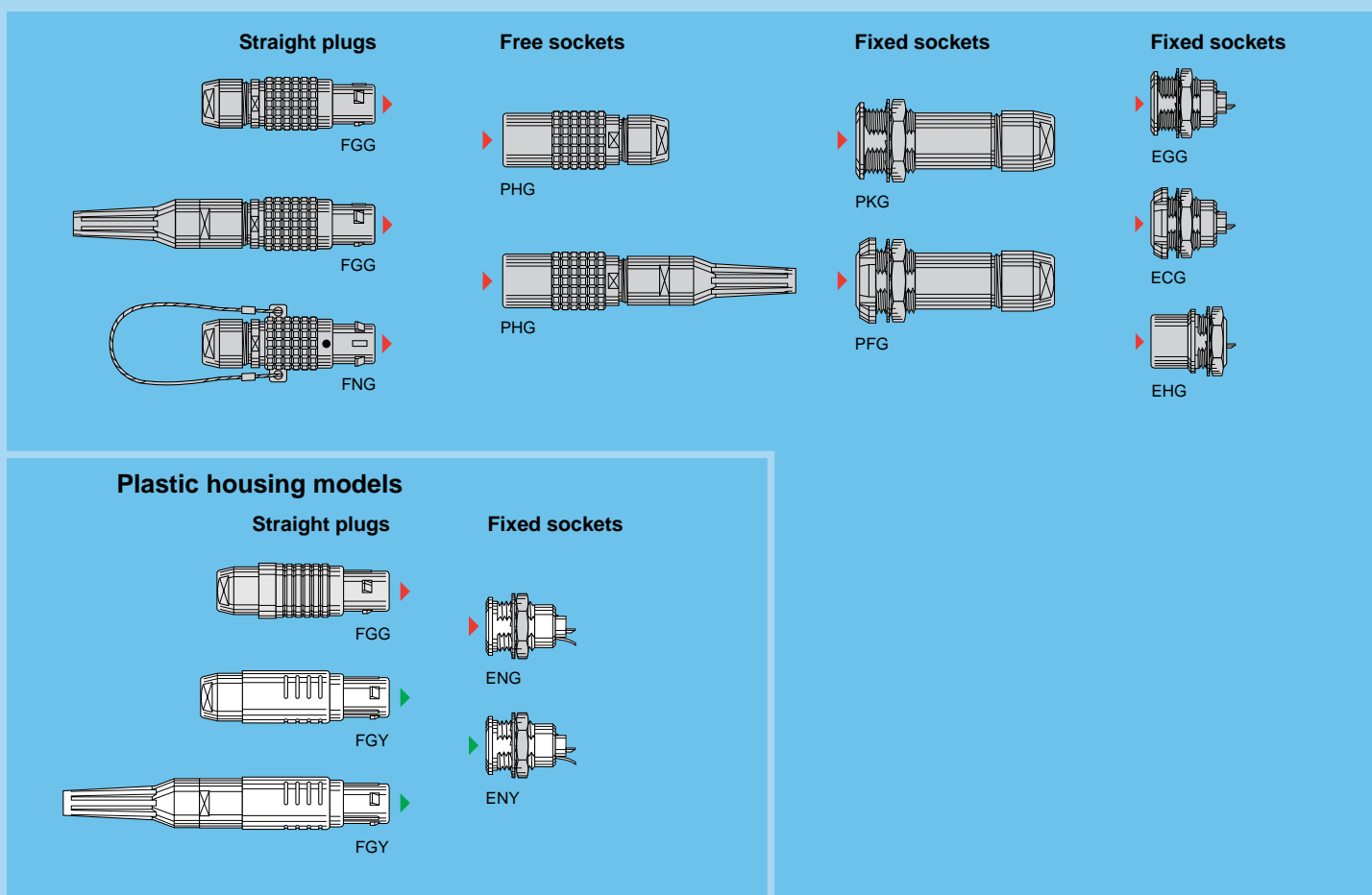

Model Description

- | | | |
|--|--|--|
| ECG Fixed socket, with two nuts, key (G) or keys (A...L and R), (back panel mounting) | FGG Straight plug, key (G or J), cable collet, PEEK outer shell | PHG Free socket, key (G) or keys (A...L) and cable collet and nut for fitting a bend relief |
| EGG Fixed socket, nut fixing, key (G) or keys (A...L and R) | FGY Straight plug, keys (Y), cable collet and PSU or PPSU outer shell | PKG Fixed socket, nut fixing, key (G) or keys (A...L and R) and cable collet |
| EHG Fixed socket, nut fixing, key (G) or keys (A...L and R) with visible shell | FGY Straight plug, keys (Y), cable collet and PSU or PPSU outer shell and nut for fitting a bend relief | |
| ENG Fixed socket with grounding tab, nut fixing, key (G or J), PEEK outer shell | FNG Straight plug, key (G) or keys (A...L and R) and cable collet with lanyard release | |
| ENY Fixed socket with grounding tab, nut fixing, keys (Y), PSU or PPSU outer shell | PFG Fixed socket, with two nuts, key (G) or keys (A...L and R) and cable collet (back panel mounting) | |
| FGG Straight plug, key (G) or keys (A...L and R) and cable collet | PHG Free socket, key (G) or keys (A...L and R) and cable collet | |
| FGG Straight plug, key (G) or keys (A...L) cable collet and nut for fitting a bend relief | | |

Part Section Showing Internal Components

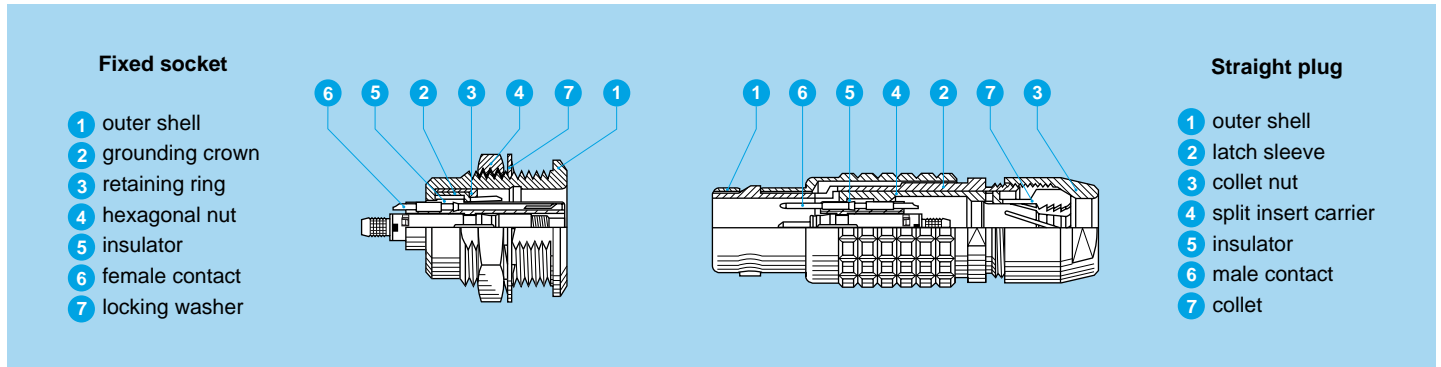

Technical Characteristics

Mechanical and Environmental

Characteristics	Value	Standard
Mating durability	> 5000 cycles	IEC 60512-5 test 9a
Humidity	up 95% to 60°C	
Temperature cycling	-55°C + 90°C	
Resistance to vibration	10-2000 Hz, 15 g	IEC 60512-4 test 6d
Shock resistance	100 g, 6 ms	IEC 60512-4 test 6c
Salt spray corrosion test ¹⁾	> 144h	IEC 60512-6 test 11f
Protection index (mated)	IP 50	IEC 60529

Note: ¹⁾ The outer shells are in chrome-plated brass (Cr1).

Electrical

Characteristics	Value	Standard
Shielding efficiency	at 10 MHz	> 75 dB
	at 1 GHz	> 40 dB

Note:

The various tests have been carried out with FGG and EGG connector pairs, with chrome-plated brass shell and PEEK insulator. Detailed electrical characteristics, as well as materials and treatment are presented in the chapter Technical Characteristics on page 107.

Optical

Note: Detailed optical performances for F1 or F2 fibre optic contacts are given on pages 109 to 111.

Alignment Key and Polarized Keying Systems

Front view of a socket	Model	No of keys	Angle	Series				Type of fibre optic or LV contact		Note
				2B	3B	4B	5B	Plug	Socket	
					●●G	1	α	0°	0°	
●●A	2	30°	30°	30°	30°	male		female	●	
●●B	2	45°	45°	45°	45°	male		female	●	
●●C	2	60°	60°	60°	60°	male		female	●	
●●D	2	γ	95°	95°	95°	95°	male	female	○	
●●E	2		β	120°	120°	120°	120°	male	female	○
●●F	2	145°		145°	145°	145°	male	female	○	
●●J	2	α	37.5°	37.5°	37.5°	37.5°	female	male	●	
●●K	2		52.5°	52.5°	52.5°	52.5°	female	male	○	
●●L	2	γ	70°	70°	70°	70°	female	male	○	
●●Y	3	β	112.5°	126°	–	–	male	female	● ¹⁾	
			γ	100°	102°	–				–

Front view of a socket	Model	No of keys	Angle	Series				Type of fibre optic or LV contact		Note
				2B	3B	4B	5B	Plug	Socket	
					●●R	5	α	–	–	
β	–	–	–	115°						
γ	–	–	–	20°						
δ	–	–	–	30°						

Note: FGY, ENY models are not available with all the keys. Please consult pages corresponding to these models.
¹⁾ Only FGY and ENY models are available.

● First choice alternative ○ Special order alternative

Part Number Example

A different part number structure is applicable for each of the following product types:

- Plugs or sockets for assembly onto cables
- Fixed sockets.

Straight plug

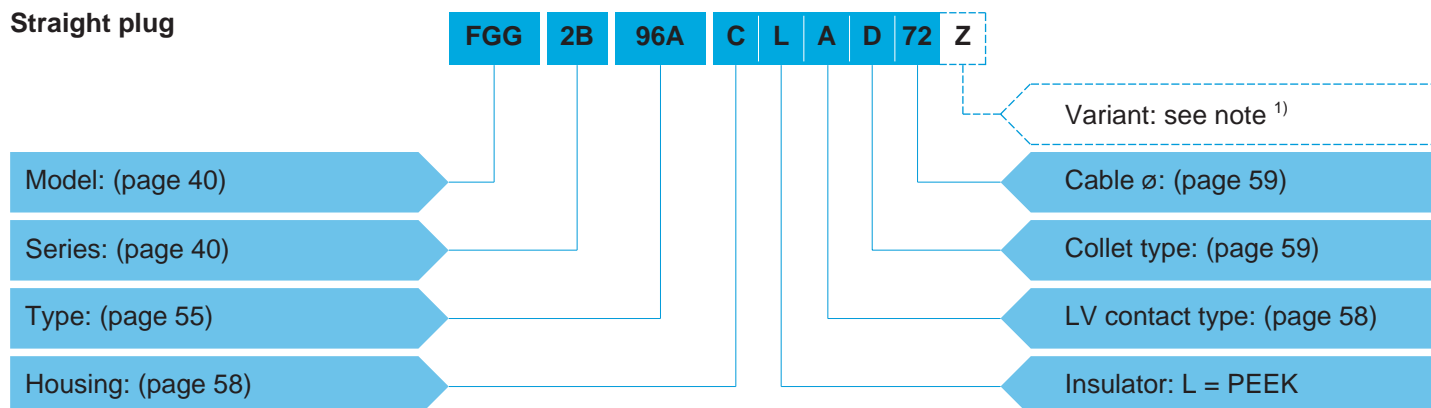

FGG.2B.96A.CLAD72Z = Straight plug with key (G), 2B series, mixed type to accept 1 F1 fibre optic contact and 2 low voltage electrical contacts, chrome-plated brass housing, PEEK insulator, 2 male solder electrical contacts, type D collet system to suit a 7.2 mm diameter cable, and a nut for fitting a bend relief.

Free socket

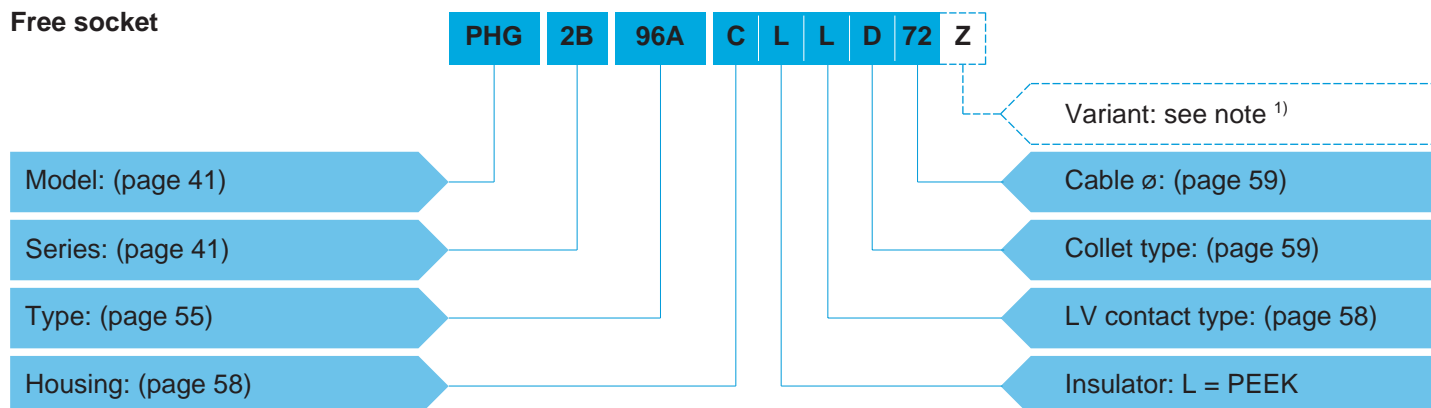

PHG.2B.96A.CLLD72Z = Free socket with key (G), 2B series, mixed type to accept 1 F1 fibre optic contact and 2 low voltage electrical contacts, chrome-plated brass housing, PEEK insulator, 2 female solder electrical contacts, type D collet system to suit a 7.2 mm diameter cable, and a nut for fitting a bend relief.

Fixed socket

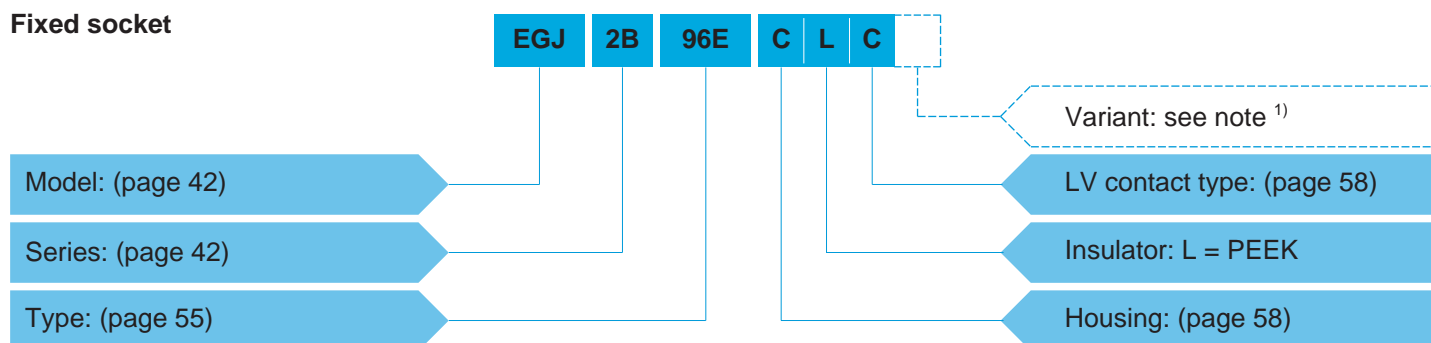

EGJ.2B.96E.CLC = Fixed socket with key (code J) 2B series, mixed type to accept 1 F1 fibre optic contact and 6 low voltage electrical contacts, chrome-plated brass housing, PEEK insulator, 6 male crimp electrical contacts.

Connectors are delivered without fibre optic contacts, therefore they must be ordered separately according to the size and type of fibre (see pages 77 and 79). In case of hybrid with coax contacts type C, connectors are delivered without the coax contact. See page 58 for ordering.

Note: ¹⁾ The «Variant» position in the reference is used to specify either the presence of a collet nut for fitting the bend relief, or the anodized colour of the housing in aluminium alloy. For models with collet nut for fitting the bend relief, a «Z» should be indicated and a bend relief can be ordered separately as indicated in the «Accessories» section. An order for a connector with bend relief should thus include two part numbers. For the various housings available in colours, the corresponding letter in the part number for the colour is indicated on page 61.

Models - Series

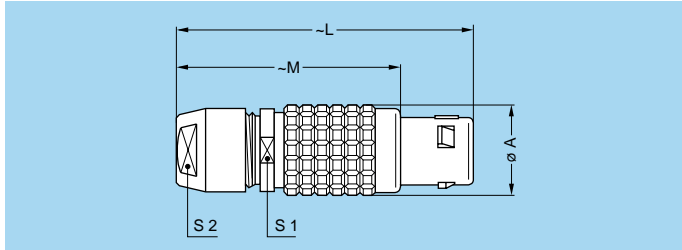
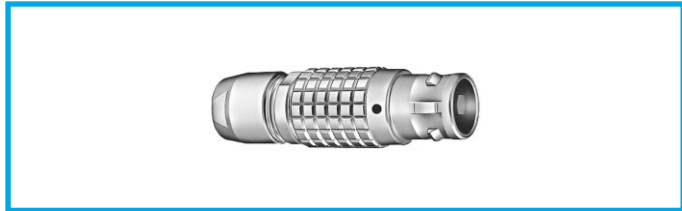

FGG Straight plug, key (G) or keys (A...L and R) and cable collet

Reference		Dimensions (mm)				
Model	Series	A	L	M	S1	S2
FGG	2B	15	50	38	13	12
FGG	3B	18	58	43	15	14
FGG	4B	25	75	57	21	20
FGG	5B	35	103	78	31	30

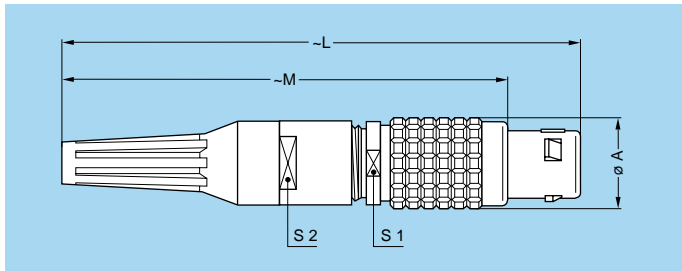
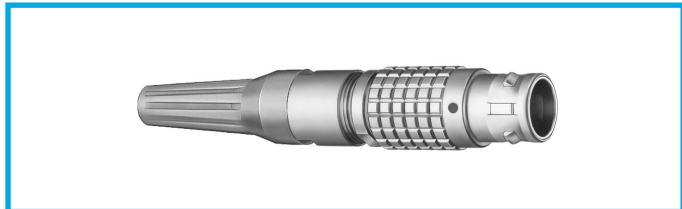

FGG Straight plug, key (G) or keys (A...L) cable collet and nut for fitting a bend relief

Reference		Dimensions (mm)				
Model	Series	A	L	M	S1	S2
FGG	2B	15	84.0	72.0	13	12
FGG	3B	18	98.5	83.5	15	15
FGG	4B	25	131.0	113.0	21	20
FGG	5B	35	167.5	142.5	31	30

Note: The bend relief must be ordered separately (see pages 61 and 91). The overall length dimension is with Desmopan bend relief (see pages 91 and 92).

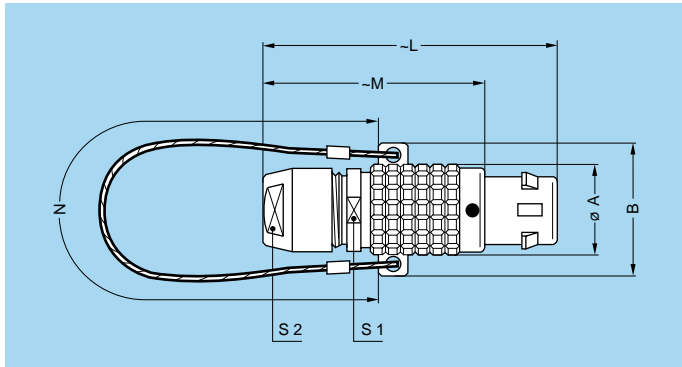
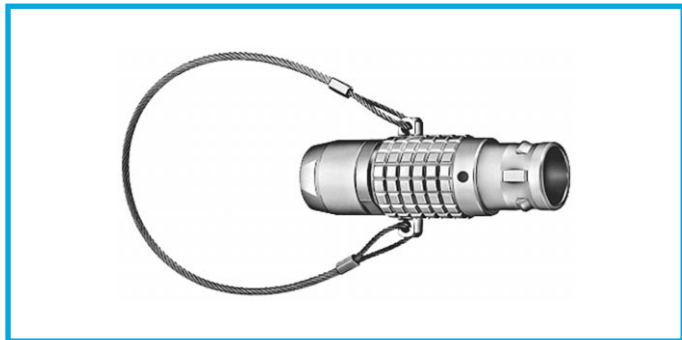

FNG Straight plug, key (G) or keys (A...L and R) and cable collet with lanyard release

Reference		Dimensions (mm)						
Model	Series	A	B	L	M	N	S1	S2
FNG	2B	15	22.6	49	37	160	13	12
FNG	3B	18	25.6	58	43	190	15	14
FNG	4B	25	35.2	75	57	230	21	20
FNG	5B	35	47.0	103	78	300	31	30

Note: Cable material: stainless steel with PVC sheath.

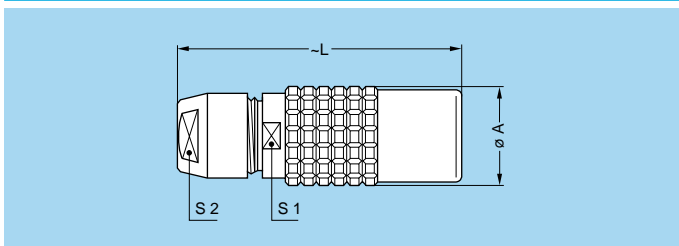
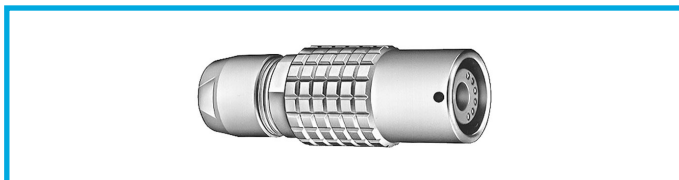

PHG Free socket, key (G) or keys (A...L and R) and cable collet

Reference		Dimensions (mm)			
Model	Series	A	L	S1	S2
PHG	2B	16.5	47	13	12
PHG	3B	19.0	56	15	14
PHG	4B	24.4	73	21	20
PHG	5B	34.2	99	31	30

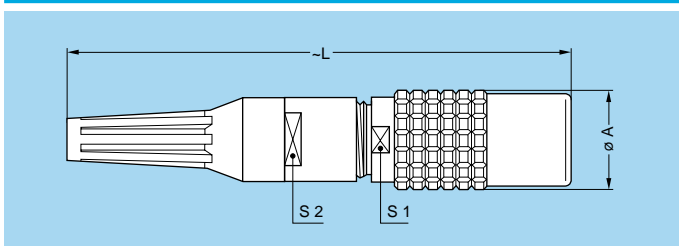
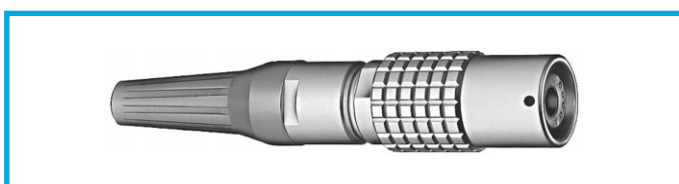

PHG Free socket, key (G) or keys (A...L) and cable collet and nut for fitting a bend relief

Reference		Dimensions (mm)			
Model	Series	A	L	S1	S2
PHG	2B	16.5	82.0	13	12
PHG	3B	19.0	96.5	15	15
PHG	4B	24.4	129.0	21	20
PHG	5B	34.2	163.5	31	30

Note: The bend relief must be ordered separately (see pages 61 and 91). The overall length dimension is with Desmopan bend relief (see pages 91 and 92).

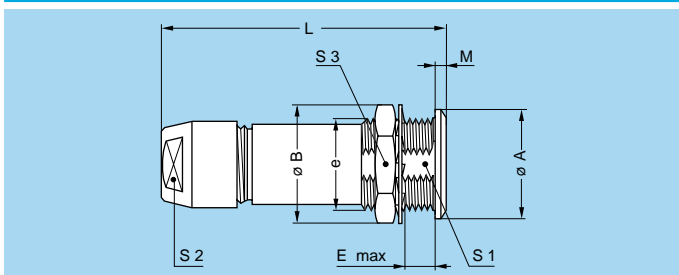
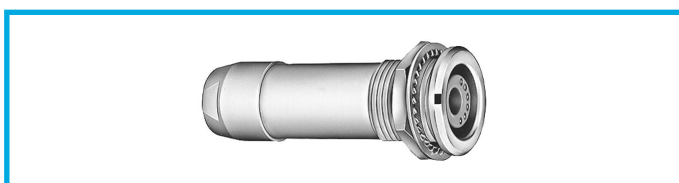

PKG Fixed socket, nut fixing, key (G) or keys (A...L and R) and cable collet

Reference		Dimensions (mm)								
Model	Series	A	B	e	E	L	M	S1	S2	S3
PKG	2B	18	19.2	M15x1	8.5	47	1.8	13.5	12	17
PKG	3B	22	25.0	M18x1	11.5	56	2.0	16.5	14	22
PKG	4B	28	34.0	M25x1	12.5	73	2.5	23.5	20	30
PKG	5B	40	40.0	M35x1	11.0	99	3.0	33.5	30	-

Panel cut-out: **P1** (see page 45)

Note: The 5B series is delivered with a tapered washer and a round nut (see pages 94 and 95).

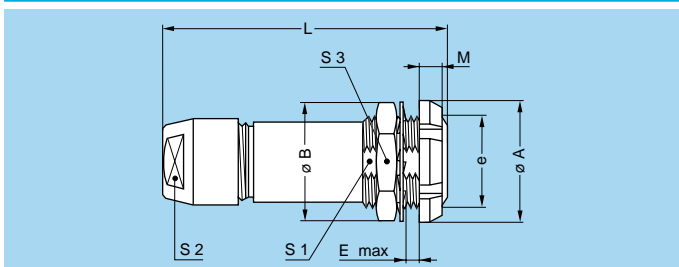
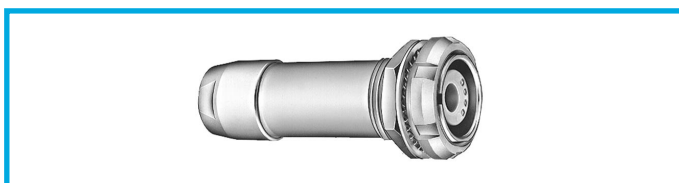

PFG Fixed socket, with two nuts, key (G) or keys (A...L and R) and cable collet, (back panel mounting)

Reference		Dimensions (mm)								
Model	Series	A	B	e	E	L	M	S1	S2	S3
PFG	2B	20	19.2	M15x1	6.5	47	3.5	13.5	12	17
PFG	3B	24	25.0	M18x1	9.0	56	4.5	16.5	14	22
PFG	4B	30	34.0	M25x1	11.0	73	4.5	23.5	20	30
PFG	5B	41	40.0	M35x1	10.0	99	5.0	33.5	30	-

Panel cut-out: **P1** (see page 45)

Note: The 3B, 4B and 5B series are delivered with a conical nut. The 5B series is delivered with a tapered washer and a round nut (see pages 94 and 95).

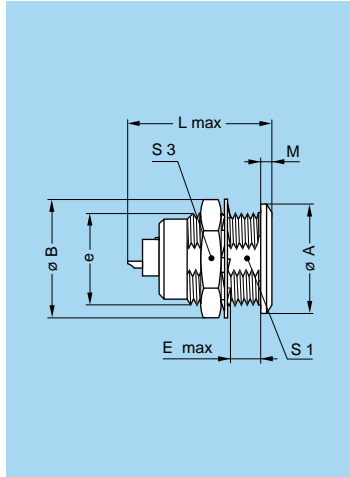

EGG Fixed socket, nut fixing, key (G) or keys (A...L and R)

Reference		Dimensions (mm)								
Model	Series	A	B	e	E	L max ¹⁾		M	S1	S3
						F1	F2			
EGG	2B	18	19.2	M15x1	8.5	27.0	37.0	1.8	13.5	17
EGG	3B	22	25.0	M18x1	11.5	30.0	37.0	2.0	16.5	22
EGG	4B	28	34.0	M25x1	12.0	34.5	38.5	2.5	23.5	30
EGG	5B	40	40.0	M35x1	11.0	36.5	38.0	3.0	33.5	-

Panel cut-out: **P1** (see page 45)

Note: ¹⁾ The overall length (L) may vary depending upon the type of electrical LV or fibre optic contact fitted. The 5B series is delivered with a tapered washer and a round nut (see pages 94 and 95).

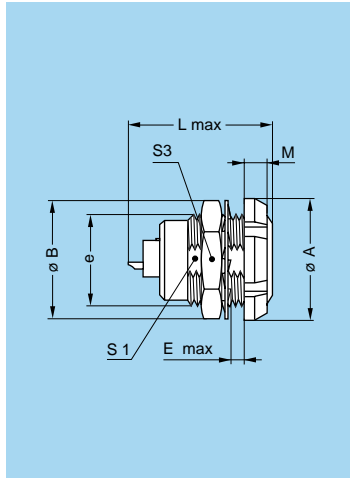

ECG Fixed socket, with two nuts, key (G) or keys (A...L and R), (back panel mounting)

Reference		Dimensions (mm)								
Model	Series	A	B	e	E	L max ¹⁾		M	S1	S3
						F1	F2			
ECG	2B	20	19.2	M15x1	6.5	27.0	37.0	3.5	13.5	17
ECG	3B	24	25.0	M18x1	9.0	30.0	37.0	4.5	16.5	22
ECG	4B	30	34.0	M25x1	10.0	34.5	38.5	4.5	23.5	30
ECG	5B	41	40.0	M35x1	9.0	36.5	38.0	5.0	33.5	-

Panel cut-out: **P1** (see page 45)

Note: ¹⁾ The overall length (L) may vary depending upon the type of electrical LV or fibre optic contact fitted. The 3B, 4B and 5B series are delivered with a conical nut. The 5B series is delivered with a tapered washer and a round nut (see pages 94 and 95).

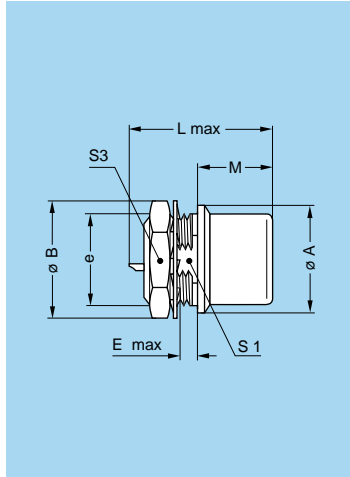

EHG Fixed socket, nut fixing, key (G) or keys (A...L and R), visible shell

Reference		Dimensions (mm)								
Model	Series	A	B	e	E	L max ¹⁾		M	S1	S3
						F1	F2			
EHG	2B	18	19.2	M15x1	5.2	27.0	37.0	12.5	13.5	17
EHG	3B	22	25.0	M18x1	4.2	30.0	37.0	12.5	16.5	22
EHG	5B	40	40.0	M35x1	2.5	36.5	38.0	28.5	33.5	-

Panel cut-out: **P1** (see page 45)

Note: ¹⁾ The overall length (L) may vary depending upon the type of electrical LV or fibre optic contact fitted. The 5B series is delivered without locking washer or tapered washer and with a round nut (see pages 94 and 95).

Plastic housing models

FGG, FGY, ENG and ENY plug and socket models are available with the outer shell and collet nut made with various insulating materials.

These connectors are particularly recommended for all applications requiring maximum electrical insulation when mated. The design, including a latch sleeve and a metal grounding crown, guarantees EMC screening efficiency to meet most requirements.

Technical Characteristics

Mechanical and Environmental

Characteristics	Value			Standard
	PEEK	PSU	PPSU	
Colour	natural (beige)	white or grey	cream	–
Endurance	> 5000 cycles	> 5000 cycles	> 5000 cycles	IEC 60512-5 test 9a
Humidity	up to 95% at 60°C			–
Temperature range	-50°C/+250°C	-50°C/+150°C	-50°C/+180°C	–
Sterilization resistance ¹⁾	~200 cycles	~20 cycles	~100 cycles	IEC 60601-1 § 44.7
Resistance to solvents	very good	limited	good	–

Note: 1) Steam sterilization

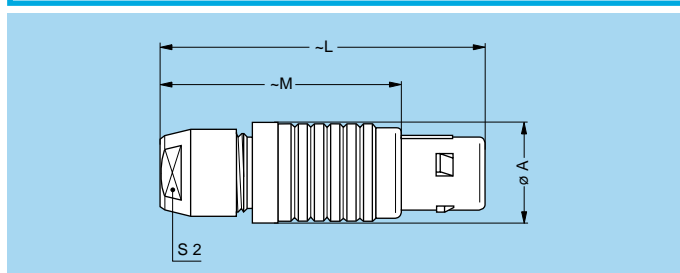
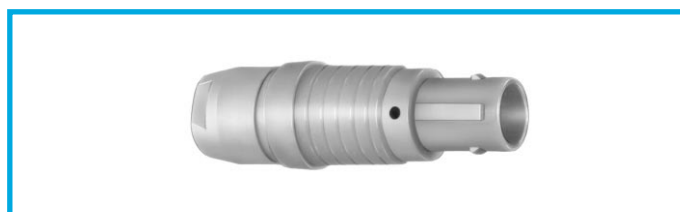

FGG Straight plug, key (G or J), cable collet, PEEK outer shell

Reference		Dimensions (mm)			
Model	Series	A	L	M	S2
FGG	3B	19.0	62.0	47.0	15
FGG	4B	26.0	78.5	60.5	20

Note: Model also available with a nut for fitting a bend relief.

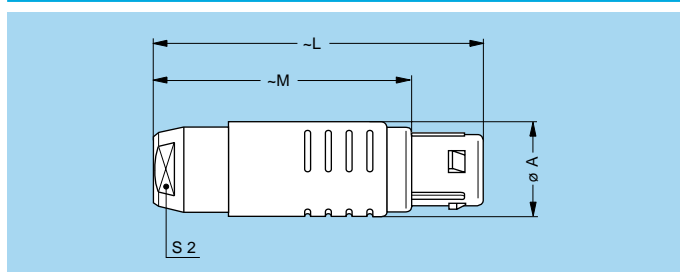
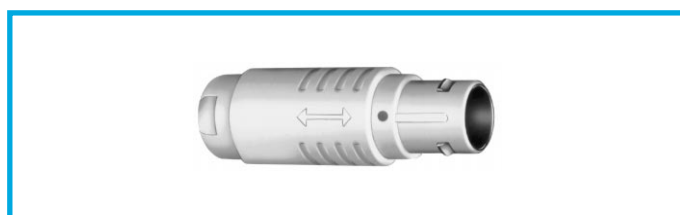

FGY Straight plug, keys (Y), cable collet and PSU or PPSU outer shell

Reference		Dimensions (mm)			
Model	Series	A	L	M	S2
FGY	2B	16.5	50.5	39.5	13
FGY	3B	19.0	58.0	43.0	15
FGY	4B	26.0	76.2	58.2	20

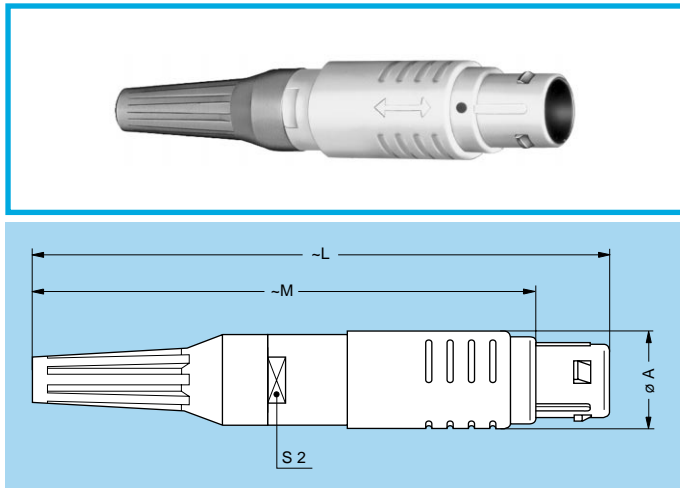

FGY Straight plug, keys (Y), cable collet and PSU or PPSU outer shell and nut for fitting a bend relief

Reference		Dimensions (mm)			
Model	Series	A	L	M	S2
FGY	2B	16.5	81	70	13
FGY	3B	19.0	94	79	15

Note: The bend relief must be ordered separately (see pages 61 and 91). The overall length dimension is with Desmopan bend relief (see pages 91 and 92).

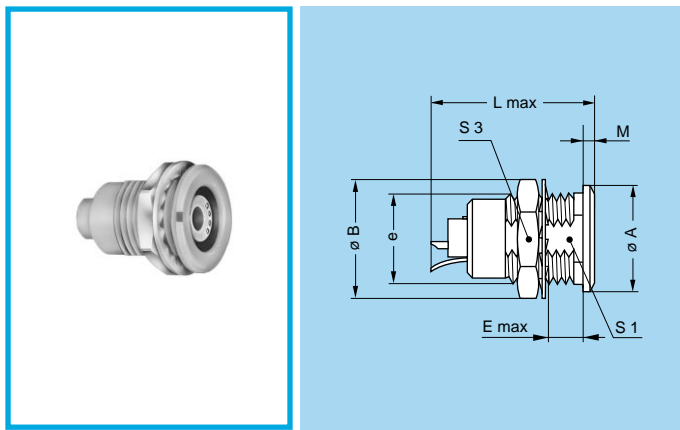

ENG Fixed socket with grounding tab, nut fixing, key (G or J), PEEK outer shell

Reference		Dimensions (mm)								
Model	Series	A	B	e	E	L max ¹⁾		M	S1	S3
						F1	F2			
ENG	3B	22	25.0	M18x1	11.5	30.0	37.0	2.0	16.5	22
ENG	4B	28	34.0	M25x1	12.0	34.5	38.5	2.5	23.5	30

Panel cut-out: **P1** (see page 45)

Note: ¹⁾ The overall length (L) may vary depending upon the type of electrical LV or fibre optic contact fitted.

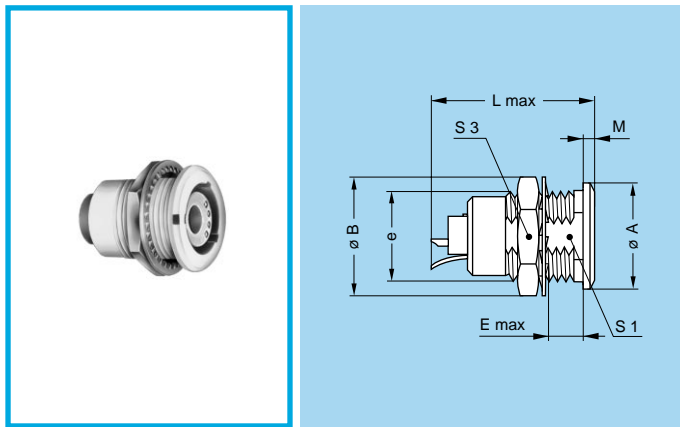

ENY Fixed socket with grounding tab, nut fixing, keys (Y), PSU or PPSU outer shell

Reference		Dimensions (mm)								
Model	Series	A	B	e	E	L max ¹⁾		M	S1	S3
						F1	F2			
ENY	2B	18	19.2	M15x1	8.5	27.0	37.0	1.8	13.5	17
ENY	3B	22	25.0	M18x1	11.5	30.0	37.0	2.0	16.5	22
ENY	4B	28	34.0	M25x1	12.0	34.5	38.5	2.5	23.5	30

Panel cut-out: **P1** (see page 45)

Note: ¹⁾ The overall length (L) may vary depending upon the type of electrical LV or fibre optic contact fitted.

Note: Other models with plastic outer shell are available on request.

▶ Tooling

Fibre optic contacts

The full range of tools for terminating fibre optic contacts F1 or F2 used with these 2B-5B series is shown on pages 103 to 106.

Consult the factory for the termination instructions.

Electrical contacts

The specific tools that may be used for the termination of crimp LV contacts or the type C coax contacts are shown on pages 100 to 102.

Panel Cut-Outs

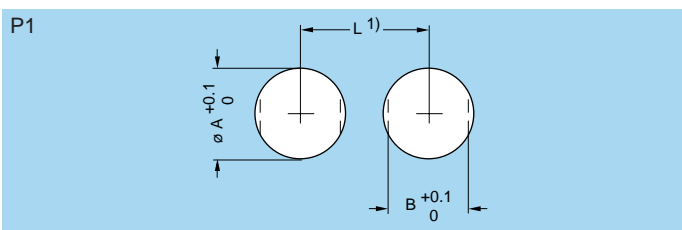

Series	Dimensions (mm)		
	A	B	L
2B	15.1	13.6	21.5
3B	18.2	16.6	27.0
4B	25.2	23.6	34.0
5B	35.2	33.6	44.0

Note: ¹⁾ Minimum distance between two neighbouring components.

Mounting torque

Series	Torque (Nm)		
	Metal shell	Metal shell with GRA insulating washer	Plastic shell
2B	6.0	0.8	0.8
3B	9.0	1.0	1.0
4B	12.0	5.0	5.0
5B	17.0	–	–

Note: The values shown in the table above are the maximum torque for each connector type.

2K-5K Series

The 2K-5K series connectors are designed to work with the LEMO **F1** or **F2** fibre optic contacts.

The main features of these series are as follows:

- Security of the LEMO Push-Pull self-latching system
- Specially designed for outdoors applications. All these models are waterproof when mated and reach a protection index of IP 66-IP 68, according to the IEC 60529 standard
- Protection against accidental contamination or damage to the fibre end face because the ferrules are recessed within the connector shell
- The alignment key (G, A...F, L and R) ensures excellent repeatability of performance during frequent matings
- A choice of configurations of multi fibre or mixed optical/electrical contacts.

The 2K-5K series consists of ten models which will accept outer cable diameters ranging from 3.6 mm to 23.5 mm.

Depending upon the type of fibre optic contact chosen, the connectors can accommodate single-mode fibres in Si/Si 9/125 or multi-mode fibres in silica or plastic with dimensions reaching 1500 µm.

Interconnections

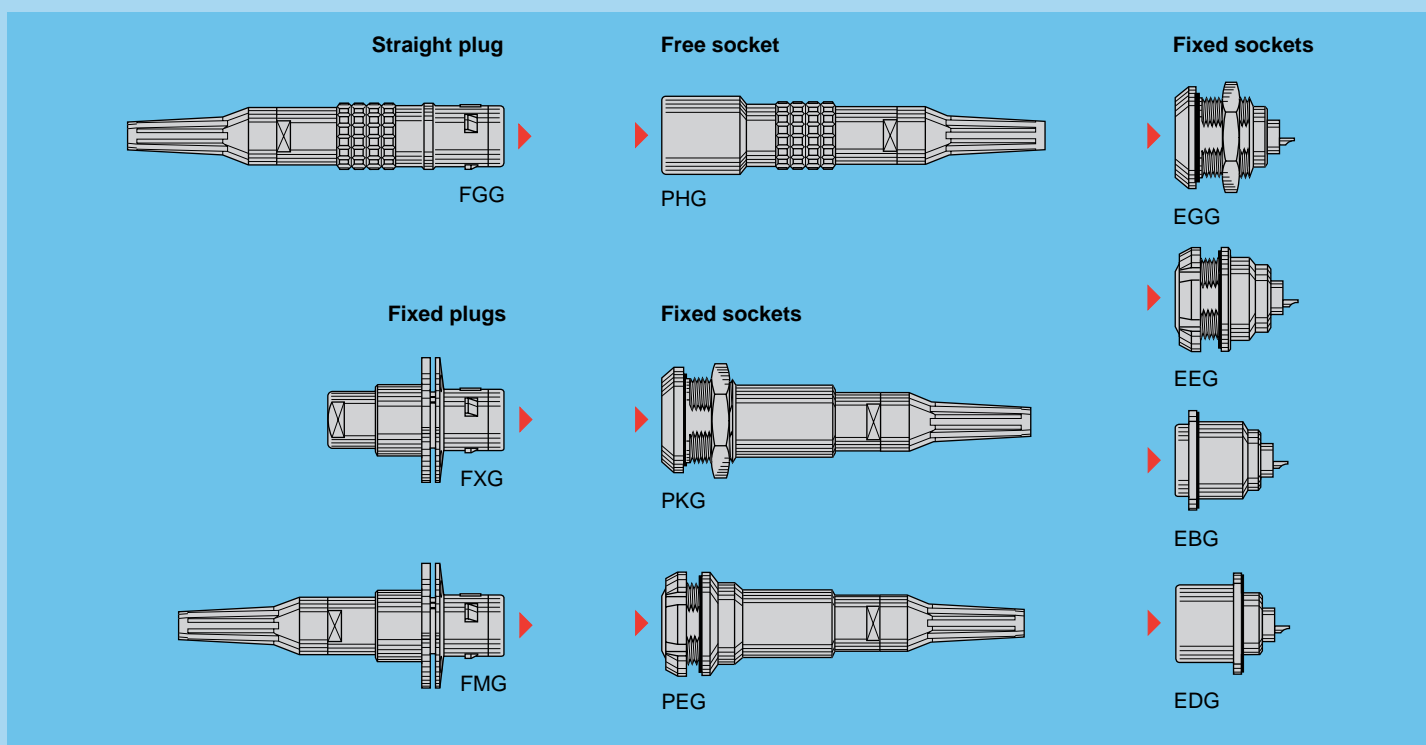

Model Description

EBG Fixed socket with square flange, key (G) or keys (A...F, L and R), four holes fixing

EDG Fixed socket with square flange, key (G) or keys (A...F, L and R), protruding shell and earthing tag, screw fixing

EEG Fixed socket, nut fixing, key (G) or keys (A...F, L and R) (back panel mounting)

EGG Fixed socket, nut fixing, key (G) or keys (A...F, L and R)

FGG Straight plug, key (G) or keys (A...F, L and R), cable adapter and nut for fitting a bend relief

FMG Fixed plug with round flange, four holes fixing, key (G) or keys (A...F, L and R), cable adapter and nut for fitting a bend relief

FXG Fixed plug with round flange, four holes fixing, key (G) or keys (A...F, L and R)

PKG Fixed socket, nut fixing, key (G) or keys (A...F, L and R), cable adapter and nut for fitting a bend relief (back panel mounting)

PHG Free socket, key (G) or keys (A...F, L and R), cable adapter and nut for fitting a bend relief

PEG Fixed socket, nut fixing, key (G) or keys (A...F, L and R), cable adapter and nut for fitting a bend relief

Part Section Showing Internal Components

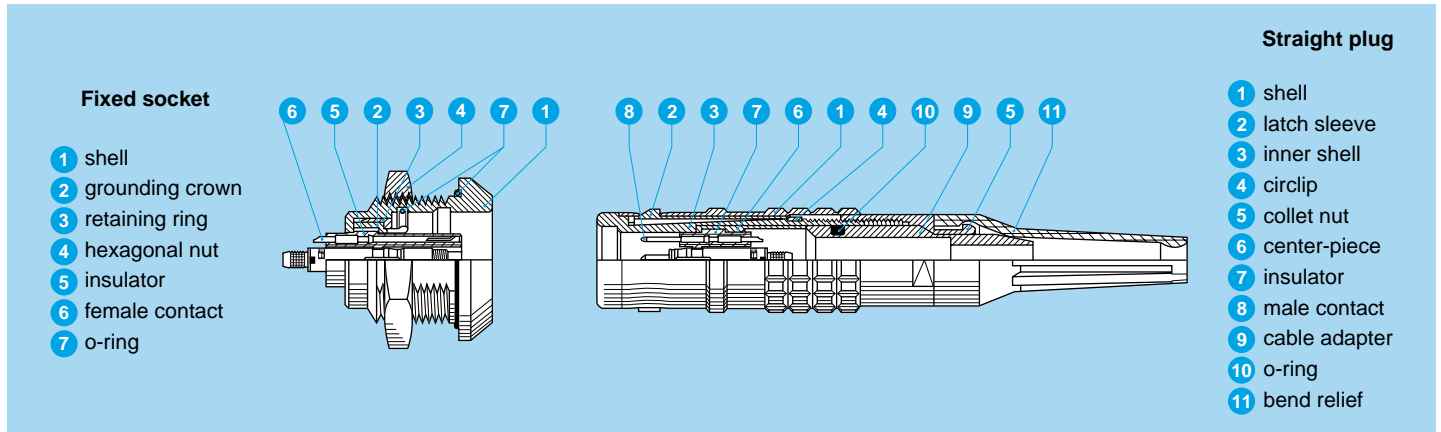

Technical Characteristics

Mechanical and Environmental

Characteristics	Value	Standard
Mating durability	> 5000 cycles	IEC 60512-5 test 9a
Humidity	up to 95% at 60°C	
Temperature range	-50°C + 200°C	
Resistance to vibrations	10-2000 Hz, 15 g	IEC 60512-4 test 6d
Shock resistance	100 g, 6 ms	IEC 60512-4 test 6c
Salt spray corrosion test ¹⁾	> 144h	IEC 60512-6 test 11f
Protection index (mated)	IP 68/IP 66	IEC 60529

Note: 1) The outer shells are in chrome-plated brass (Cr1). The various tests have been carried out with FGG and EGG connector pairs, with chrome-plated brass shell, PEEK insulator and silicone O-ring. Detailed electrical characteristics, as well as materials and treatment are presented in the chapter Technical Characteristics on page 107.

Electrical

Characteristics	Value	Standard
Shielding efficiency	at 10 MHz	> 95 dB
	at 1 GHz	> 80 dB
		IEC 60169-1-3
		IEC 60169-1-3

Optical

Note: Detailed optical performances for F1 or F2 fibre optic contacts are given on pages 109 to 111.

Alignment Key and Polarized Keying Systems

Front view of a socket 	Model	No of keys	Angles	Series				Type of electrical or fibre optic contact		Note
				2K	3K	4K	5K	Plug	Socket	
	●●G	1	α	0°	0°	0°	0°	male	female	●
	●●A	2		30°	30°	30°	30°	male	female	●
	●●B	2		45°	45°	45°	45°	male	female	●
	●●C	2		60°	60°	60°	60°	male	female	●
	●●D	2	γ	95°	95°	95°	95°	male	female	○
	●●E	2	β	120°	120°	120°	120°	male	female	○
	●●F	2	β	145°	145°	145°	145°	male	female	○
	●●L	2	γ	75°	75°	75°	75°	female	male	●

Front view of a socket 	Model	No of keys	Angles	Series				Type of electrical or fibre optic contact		Note
				2K	3K	4K	5K	Plug	Socket	
	●●R	5	α	–	95°	–	–	male	female	●
			β	–	115°	–	–			
			γ	–	35°	–	–			
			δ	–	25°	–	–			

● First choice alternative ○ Special order alternative

Part Number Example

A different part number structure is applicable for each of the following product types:

- Plugs and free sockets for assembly onto cables
- Fixed sockets.

Straight plug with bend relief

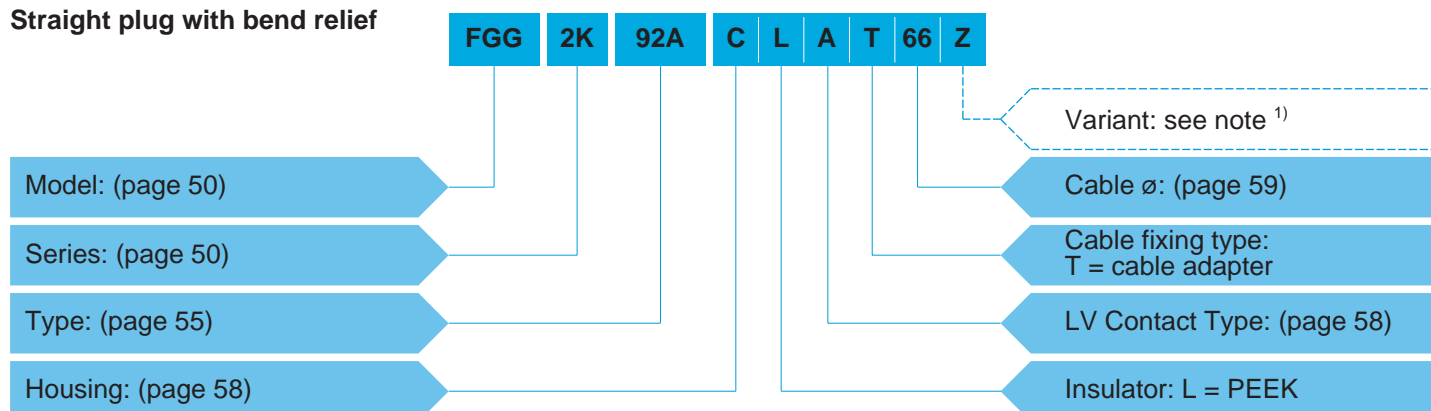

FGG.2K.92A.CLAT66Z = Straight plug with key (G), 2K series, mixed type to accept 1 F2 type fibre optic contact and 2 low voltage contacts, chrome-plated brass housing, PEEK insulator, 2 male solder electrical contacts, cable fixing type T for 6.5 mm diameter cable, and nut for fitting a bend relief.

Free socket with bend relief

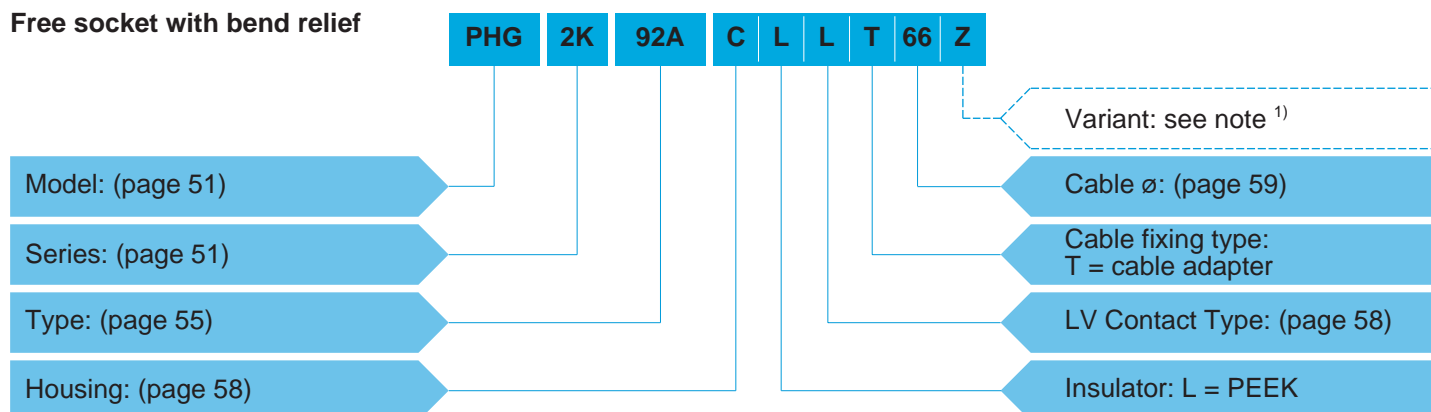

PHG.2K.92A.CLLT66Z = Free socket with key (G), 2K series, mixed type to accept 1 F2 type fibre optic contact and 2 low voltage contacts, chrome-plated brass housing, PEEK insulator, 2 female solder electrical contacts, cable fixing type T for 6.5 mm diameter cable, and nut for fitting a bend relief.

Fixed socket

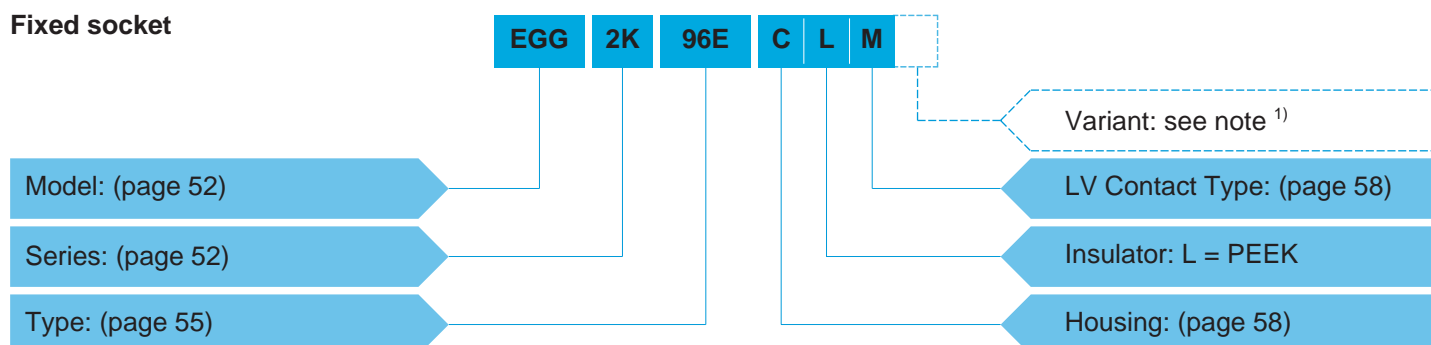

EGG.2K.96E.CLM = Fixed socket with key (G), 2K series, mixed type to accept take 1 F1 type fibre optic contact and 6 low voltage contacts, chrome-plated brass housing, PEEK insulator, 6 female crimp electrical contacts.

Connectors are delivered without fibre optic contacts, therefore they must be ordered separately according to the size and type of fibre (see pages 77 and 79). In case of hybrid (with coax contacts type C), connectors are delivered without the coax contact. See page 58 for ordering.

Note: ¹⁾ The «Variant» position in the reference is used to indicate the presence of a collet nut for fitting the bend relief. For models with the «T» type of cable adapter the «Z» should always be indicated and a bend relief can be ordered separately as indicated in the «Accessories» section. An order for a connector with bend relief should thus include two part numbers.

Models - Series

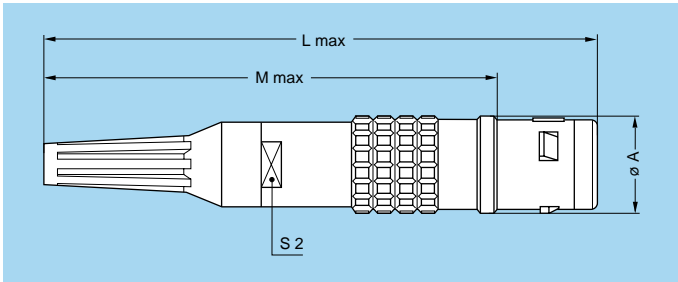
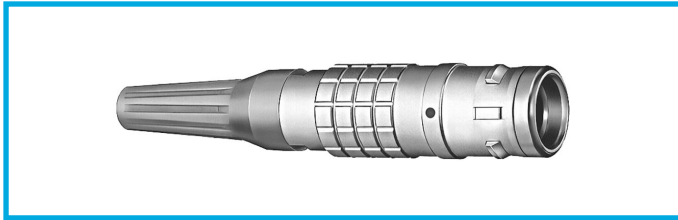

FGG Straight plug, key (G) or keys (A...F, L and R), cable adapter and nut for fitting a bend relief

Reference		Dimensions (mm)			
Model	Series	A	L	M	S2
FGG	2K	16	101	85.0	12
FGG	3K	19	109	89.0	15
FGG	4K	25	131	110.5	19
FGG	5K	38	160	135.0	30

Note: The overall length dimension is with Desmopan bend relief (see pages 91 and 92).

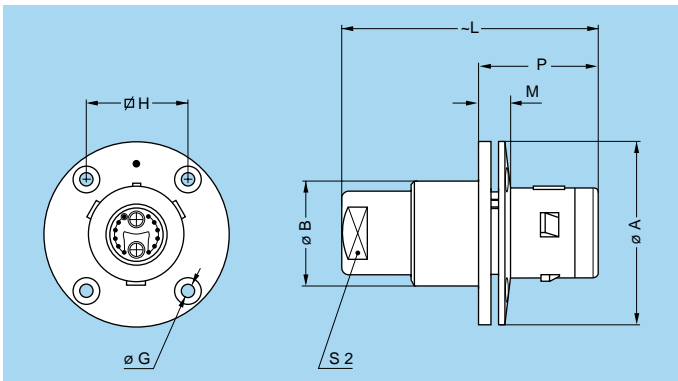
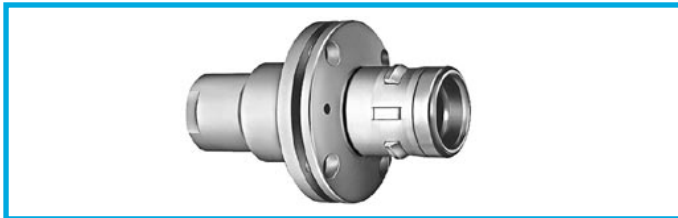

FXG Fixed plug with round flange, four holes fixing, key (G) or keys (A...F, L and R)

Reference		Dimensions (mm)							
Model	Series	A	B	G	H	L	M	P	S2
FXG	3K	38	22.5	3.4	20.6	61	10.0	30.0	15
FXG	4K	47	28.5	3.4	27.0	71	11.0	32.0	19
FXG	5K	65	42.5	4.4	38.0	100	12.5	38.5	30

Panel cut-out: **P2** (see page 53)

Note: This model does not include an O-ring behind the flange, it allows the device on which it is fitted to reach only IP50 protection index. It does not have a cable adapter.

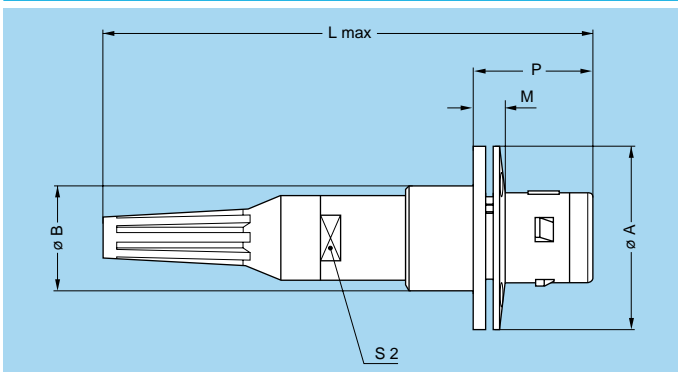
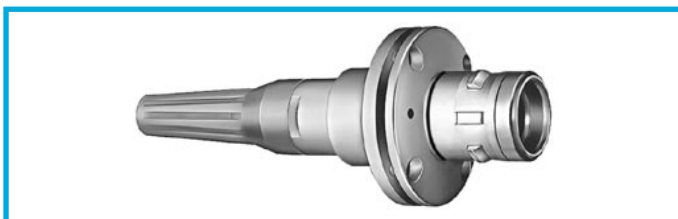

FMG Fixed plug with round flange, four hole fixing, key (G) or keys (A...F, L and R), cable adapter and nut for fitting a bend relief

Reference		Dimensions (mm)								
Model	Series	A	B	G ¹⁾	H ¹⁾	L	M	P	S2	
FMG	3K	38	22.5	3.4	20.6	109.0	10.0	30.0	15	
FMG	4K	47	28.5	3.4	27.0	131.0	11.0	32.0	19	
FMG	5K	65	42.5	4.4	38.0	163.5	12.5	38.5	30	

Panel cut-out: **P2** (see page 53)

Note: ¹⁾ See FXG drawing for front view. This model does not include an O-ring behind the flange, it allows the device on which it is fitted to reach only IP50 protection index. The overall length dimension is with Desmopan bend relief (see pages 91 and 92).

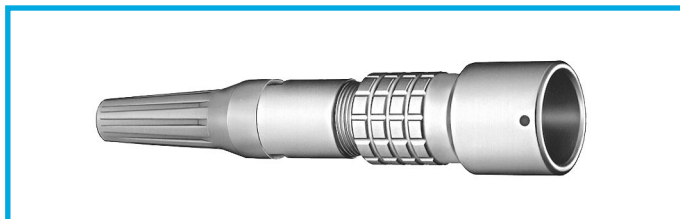

PHG Free socket, key (G) or keys (A...F, L and R), cable adapter and nut for fitting a bend relief

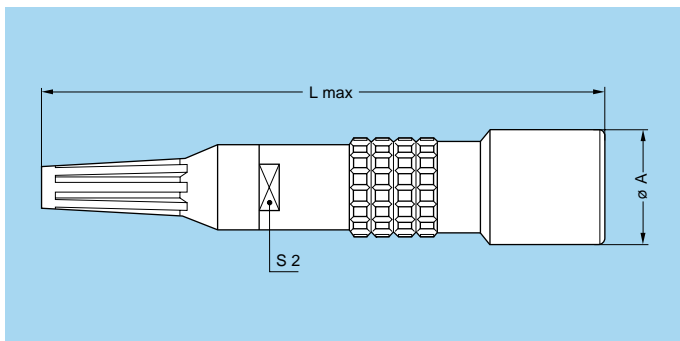

Reference		Dimensions (mm)		
Model	Series	A	L	S2
PHG	2K	19	103.0	12
PHG	3K	23	113.0	15
PHG	4K	29	135.5	19
PHG	5K	42	164.0	30

Note: The overall length dimension is with Desmopan bend relief (see pages 91 and 92).

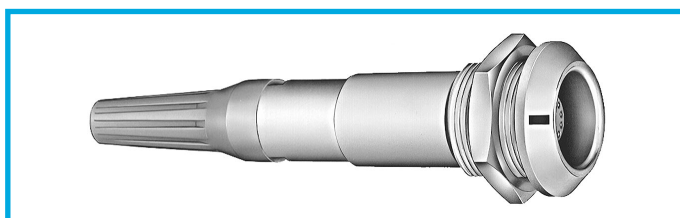

PKG Fixed socket, nut fixing, key (G) or keys (A...F, L and R) and cable adapter and nut for fitting a bend relief

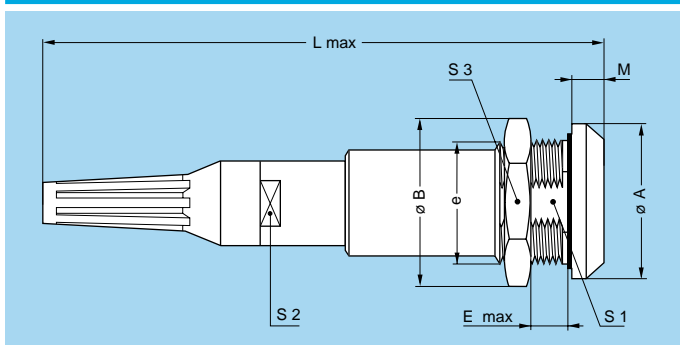

Reference		Dimensions (mm)								
Model	Series	A	B	e	E	L	M	S1	S2	S3
PKG	2K	25	27.0	M20x1.0	9	103.0	5.0	18.5	12	24
PKG	3K	31	34.0	M24x1.0	11	113.0	6.0	22.5	15	30
PKG	4K	37	40.5	M30x1.0	9	135.5	6.5	28.5	19	36
PKG	5K	55	54.0	M45x1.5	15	164.0	9.0	42.5	30	-

Panel cut-out: **P1** (see page 53)

Note: The 5K series is delivered with a round nut (see page 95). The overall length dimension is with Desmopan bend relief (see pages 91 and 92).

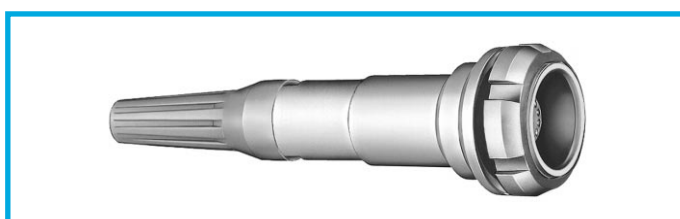

PEG Fixed socket, nut fixing, key (G) or keys (A...F, L and R), cable adapter and nut for fitting a bend relief (back panel mounting)

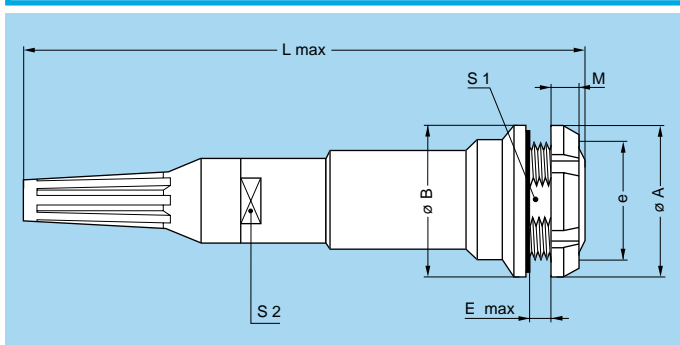

Reference		Dimensions (mm)							
Model	Series	A	B	e	E	L	M	S1	S2
PEG	2K	25	25	M20x1.0	4.0	103	3.5	18.5	12
PEG	3K	30	31	M24x1.0	7.5	113	4.5	22.5	15

Panel cut-out: **P1** (see page 53)

Note: The 3K series is delivered with a conical nut (see page 95). The overall length dimension is with Desmopan bend relief (see pages 91 and 92).

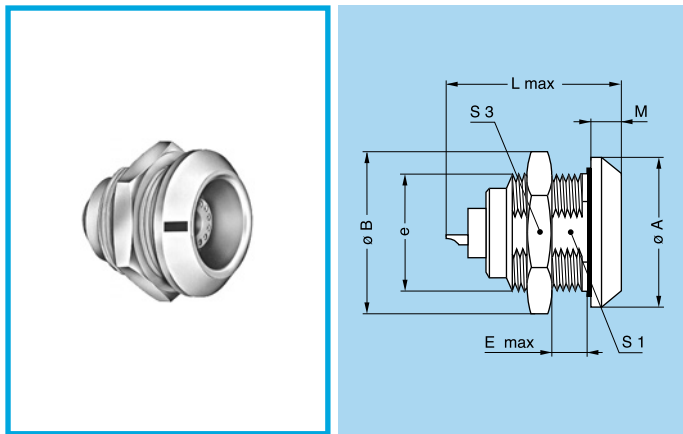

EGG Fixed socket, nut fixing, key (G) or keys (A...F, L and R)

Reference		Dimensions (mm)								
Model	Series	A	B	e	E	L max ¹⁾		M	S1	S3
						F1	F2			
EGG	2K	25	27.0	M20x1.0	9	31.0	41.0	5.0	18.5	24
EGG	3K	31	34.0	M24x1.0	11	35.5	42.5	6.0	22.5	30
EGG	4K	37	40.5	M30x1.0	9	37.0	41.0	6.5	28.5	36
EGG	5K	55	54.0	M45x1.5	10	40.5	42.0	9.0	42.5	-

Panel cut-out: **P1** (see page 53)

Note: ¹⁾ The overall length (L) may vary depending upon the type of electrical LV or fibre optic contact fitted.
The 5K series is delivered with a round nut (see page 95).

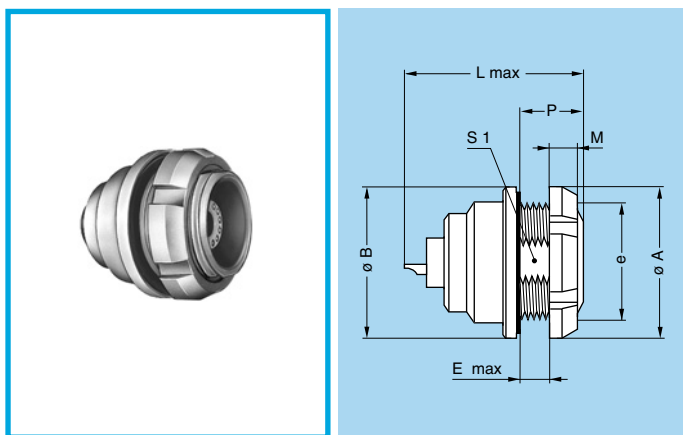

EEG Fixed socket, nut fixing, key (G) or keys (A...F, L and R) (back panel mounting)

Reference		Dimensions (mm)								
Model	Series	A	B	e	E	L max ¹⁾		M	P	S1
						F1	F2			
EEG	2K	25	25	M20x1	5.0	31.0	41.0	3.5	10	18.5
EEG	3K	30	31	M24x1	7.5	35.5	42.5	4.5	12	22.5

Panel cut-out: **P1** (see page 53)

Note: ¹⁾ The overall length (L) may vary depending upon the type of electrical LV or fibre optic contact fitted.
The 3K series is delivered with a conical nut (see page 95).

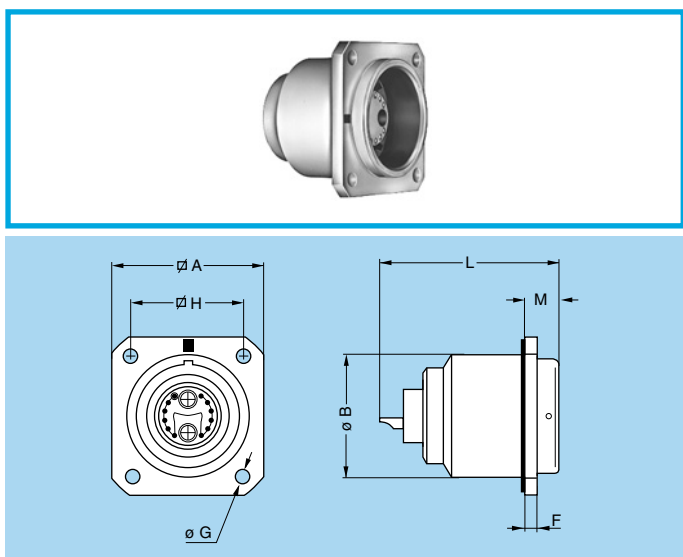

EBG Fixed socket with square flange, key (G) or keys (A...F, L and R), four holes fixing

Reference		Dimensions (mm)							
Model	Series	A	B	F	G	H	L max ¹⁾		M
							F1	F2	
EBG	3K	29	23	3	3.4	23	35.5	42.5	6.0
EBG	4K	37	30	3	3.4	29	37.0	41.0	6.5

Panel cut-out: **P3** (see page 53)

Note: ¹⁾ The overall length (L) may vary depending upon the type of electrical LV or fibre optic contact fitted.

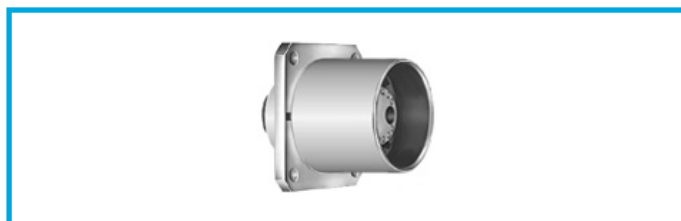

EDG Fixed socket with square flange, key (G) or keys (A...F, L and R), protruding shell and earthing tag, screw fixing

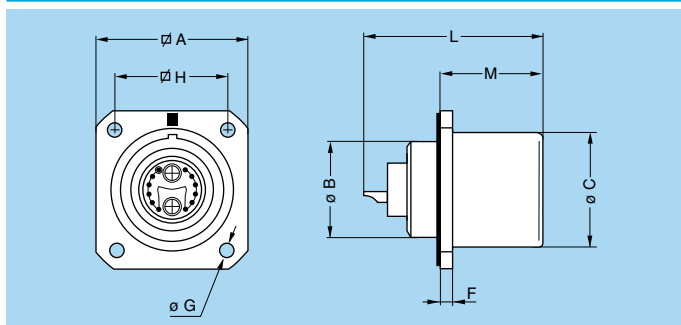

Reference		Dimensions (mm)								
Model	Series	A	B	C	F	G	H	L max ¹⁾		M
								F1	F2	
EDG	3K	29	18	23	3	3.4	23	35.5	42.5	22.5

Panel cut-out: **P4** (see page 53)

Note: ¹⁾ The overall length (L) may vary depending upon the type of electrical LV or fibre optic contact fitted.

Tooling

Fibre optic contacts

The full range of tools for terminating fibre optic contacts F1 or F2 used with these 2K-5K series is shown on pages 103 to 106.

Consult the factory for the termination instructions.

Electrical contacts

The specific tools that may be used for the termination of crimp LV contacts or the type C coax contacts are shown on pages 100 to 102.

Panel Cut-Outs

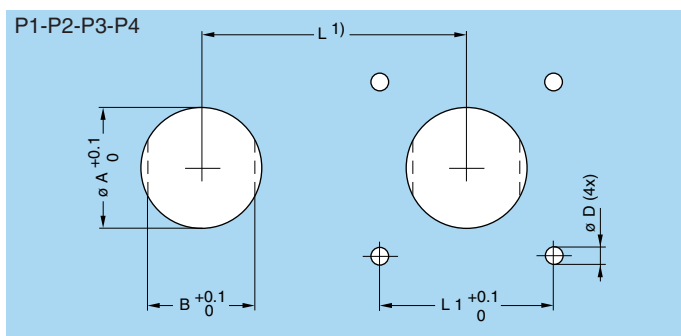

Series	P1			P2			
	$\varnothing A$	B	L	$\varnothing A$	D	L	L1
2K	20.2	18.6	29.0	-	-	-	-
3K	24.2	22.6	35.5	22.6	M3	40.0	20.6
4K	30.2	28.6	43.0	28.6	M3	49.0	27.0
5K	45.2	42.6	57.0	42.6	M4	67.0	38.0

Series	P3				P4			
	$\varnothing A$	D	L	L1	$\varnothing A$	D	L	L1
3K	23.1	M3	31.0	23.0	18.1	M3	31.0	23.0
4K	30.1	M3	39.0	29.0	-	-	-	-

Note: ¹⁾ Minimum distance between two neighbouring components.

Mounting torque

Series	Torque (Nm)	
	Nut	Screws
2K	9	-
3K	12	1 to 2 ¹⁾
4K	17	1 to 2 ¹⁾
5K	22	1 to 2 ¹⁾

Note: ¹⁾ Depends on screw material selected. The values shown in the table above are the maximum torque for each connector type.

Cut-out types

Model	Type	Model	Type
EBG	P3	FMG	P2
EDG	P4	FXG	P2
EEG	P1	PEG	P1
EGG	P1	PKG	P1

Types

Multi fibre and Mixed fibre optic (F1 or F2 contact) + LV

		Reference FO Contact Type		Low Voltage contact									
		F1	F2	Fibre optic No	Contact No	ø A (mm)	Contact type		Solder contact		Crimp contact		Rated current (A)
							Solder	Crimp	Test voltage (kV rms) ¹⁾ Contact-contact	Test voltage (kV rms) ¹⁾ Contact-shell	Test voltage (kV rms) ¹⁾ Contact-contact	Test voltage (kV rms) ¹⁾ Contact-shell	
Male solder contacts		Female solder contacts											
Male crimp contacts		Female crimp contacts											
2B 2K			96A 92A	1	2	0.9	●	●	1.75	1.60	1.85	1.60	9.0
			96C 92C	1	4	0.7	●	●	0.85	1.20	0.85	1.25	6.0
			96E 92E	1	6	0.7	●	●	0.85	1.20	0.85	1.25	6.0
			96J 92J	1	10	0.7	●	●	1.15	1.35	1.30	1.05	6.0
3B 3K			07A 03A	2	-	-	-	-	-	-	-	-	-
			97C 93B	2	4	0.9	●	●	1.20	1.05	1.00	0.80	8.0
			97E 93E	2	6	0.9	●	●	1.20	1.05	1.00	0.80	8.0
			97J 93J	2	10	0.7	●	●	0.95	0.75	0.85	0.65	6.0
			97R 93R	2	16	0.7	●	●	0.80	0.70	0.80	0.75	5.5
			96X 92X	1	22	0.7	●	●	0.80	0.70	0.80	0.75	5.0
4B 4K			07C 03C	4	-	-	-	-	-	-	-	-	-
			- 95D	4	5	1.3	●	●	1.20	1.30	1.30	1.05	13
			99H -	4	9	0.7	●	●	1.00	1.00	0.80	0.80	8
			98E 94E	3	6	0.7	●	●	0.90	0.95	0.80	0.80	8
			98L 94L	3	12	0.7	●	●	0.90	0.95	0.80	0.80	6
			- 93E	2	2 4	0.9 1.3	-	●	-	-	1.90 1.85	1.60 2.55	8 12

● First choice alternative ○ Special order alternative Note: 1) See calculation method, caution and suggested standard on page 114.

Multi fibre and Mixed fibre optic (F1 or F2 contact) + LV

		Reference FO Contact Type		Low Voltage contact													
		F1	F2	Fibre optic No	Contact No	ø A (mm)	Contact type		Solder contact		Crimp contact		Rated current (A)				
							Solder	Crimp	Test voltage (kV rms) ¹⁾ Contact-contact	Test voltage (kV rms) ¹⁾ Contact-shell	Test voltage (kV rms) ¹⁾ Contact-contact	Test voltage (kV rms) ¹⁾ Contact-shell					
Male solder contacts Female solder contacts		Male crimp contacts Female crimp contacts		Reference FO Contact Type F1 F2													
								2	3 4	0.9 1.3	-	●	-	-	1.15 1.85	1.50 2.55	8 12
						97L 93L		2	12	0.9	●	●	0.95	0.85	0.90	1.20	10
						97R 93R		2	16	0.9	●	●	0.95	0.85	0.85	0.85	10
		97T 93T		2	18	0.7	●	●	0.90	0.95	0.85	0.75	8				
		07J 03J		10	-	-	-	-	-	-	-	-	-				
		- 03N		14	-	-	-	-	-	-	-	-	-				
		- 99B		9	1 2	4 2	●	-	2.55 2.55	2.05 2.05	-	-	35 18				
		- 94B		3	10	2	●	●	2.10	2.00	2.05	1.75	18				

● First choice alternative ○ Special order alternative Note: 1) See calculation method, caution and suggested standard on page 114.

Note: The above mentioned multi fibre and mixed fibre optic + LV connectors are delivered **without** fibre optic contacts (See pages 77 and 79 for ordering).

Mixed fibre optic (F2 contact) + HV + LV

				Reference	High Voltage contact						Low Voltage contact								
					Fibre optic F2 No	Contact No	ø A (mm)	Crimp	Cont type		Rated current (A)	Contact No	ø A (mm)	Contact type		Rated current (A)			
									Test voltage (kV rms) ¹⁾ Contact-contact	Test voltage (kV rms) ¹⁾ Contact-shell				Solder	Crimp		Test voltage (kV rms) ¹⁾ Contact-contact	Test voltage (kV rms) ¹⁾ Contact-shell	Solder/ crimp cont.
		 Male solder contacts		 Female solder contacts															
		 Male crimp contacts		 Female crimp contacts															
3K	 		 		93C	2	2	1.3	●	2.25	2.25	10	2	0.9	-	●	1.00	1.00	3
	5B 5K	 		 		90C	6	4	1.6	●	2.05	1.75	15	2	1.3	●	-	1.85	2.55
		 		 		956	12	2	1.6	●	2.05	1.75	18	1	2.0	-	●	2.05	1.75

● First choice alternative ○ Special order alternative **Note:** ¹⁾ See calculation method, caution and suggested standard on page 114.

Note: The above mentioned mixed fibre optic + HV + LV connectors are delivered **without** fibre optic contacts (See page 79 for ordering). More informations about the 3K.93C series are detailed on page 71.

Mixed fibre optic (F2 contact) + coaxial + LV

				Reference	Coaxial contact						Low Voltage contact								
					Fibre optic F2 No	Contact No	Impedance (Ω)	Type	Cable group	Contact No	ø A (mm)	Contact type		Solder contact		Crimp contact		Rated current (A)	
												Solder	Crimp	Test voltage (kV rms) ¹⁾ Contact-contact	Test voltage (kV rms) ¹⁾ Contact-shell	Test voltage (kV rms) ¹⁾ Contact-contact	Test voltage (kV rms) ¹⁾ Contact-shell		
		 Male solder contacts		 Female solder contacts															
		 Male crimp contacts		 Female crimp contacts															
3B 3K	 		 		82E	1	1	50	C	1 2 3	6	0.9	●	●	1.30	1.20	0.85	0.95	10
		 		 		82R	1	1	50	C	1 2 3	16	0.7	●	●	0.85	0.85	0.60	0.80
4B 4K	 		 		05C	2	2	50	C	1 2 3	-	-	-	-	-	-	-	-	-
		 		 		88E	2	1	50	C	1 2 3	6	0.7	●	●	1.05	1.05	0.80	0.80

● First choice alternative ○ Special order alternative **Note:** ¹⁾ See calculation method, caution and suggested standard on page 114.

Note: The above mentioned mixed fibre optic + coaxial + LV connectors are delivered **without** coax contacts (See page 58 for ordering). Other configurations are available. All insulators designed for F1 F.O. contacts can accept both F1 F.O. or type C coax contacts.

Housing

Ref.	Material	Surface treatment		Note
		Outer shell and collet nut	Latch sleeve and grounding crown	
C	Brass	chrome	nickel	●
N	Brass	nickel	nickel	○
K	Brass	black chrome	nickel	●
T	Stainless steel	without treatment	stainless steel	○
L	Aluminium alloy ¹⁾	anodized	nickel-plated brass	○
G	PEEK ²⁾	without treatment	nickel-plated brass	●
P	PSU ³⁾	without treatment	nickel-plated brass	●
R	PPSU ⁴⁾	without treatment	nickel-plated brass	●

Note: Detailed characteristics of these materials and treatments are presented on page 107.

1) The «variant» position of the reference is used to specify the anodized colour.

2) Only available for FGG and ENG models of the B series.

3) Only available for ENY and FGY models of the B series. For the colour, see the «variant» position.

4) Only available for ENY and FGY models of the B series.

● First choice alternative ○ Special order alternative

Coaxial Contact

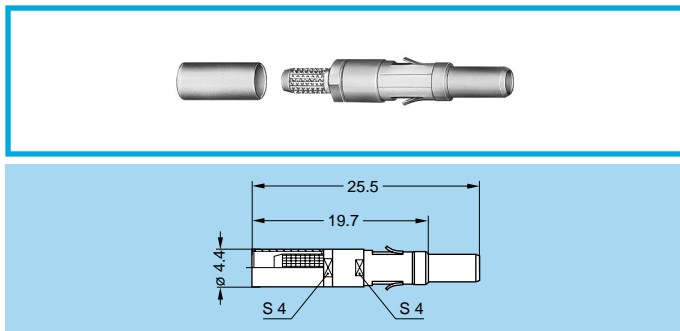

FFS Male coaxial contact type C

Part number	Cable group ¹⁾
FFS.2B.250.ZTCE24	2
FFS.2B.250.ZTCE30	1
FFS.2B.250.ZTCE31	3

Note: ¹⁾ See page 9 for cable group.

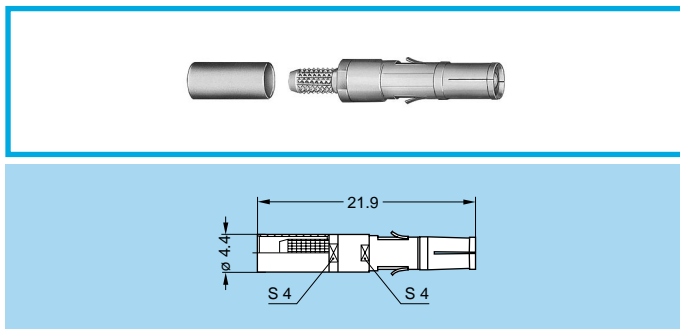

PSS Female coaxial contact type C

Part number	Cable group ¹⁾
PSS.2B.250.ZTME24	2
PSS.2B.250.ZTME30	1
PSS.2B.250.ZTME31	3

Note: ¹⁾ See page 9 for cable group.

Note: Detailed characteristics of these contacts are presented on page 113.

Electrical Contact

Contact for plug, socket, and fixed socket

Ref.	Contact type
A	male solder
C	male crimp
L	female solder
M	female crimp
Z	no contact

Collets (B and K series)

D and M type collets



	Reference		Collet \varnothing		Cable \varnothing		Collet part number ¹⁾	Reducer part number ²⁾	Reducing cone part number ²⁾	Collet nut part number
	Type	\varnothing	$\varnothing A$	$\varnothing B$	max.	min.				
2B	M	21	2.1	–	2.2	1.4	FGG.0B.722.DN	FGG.2B.138.LN	FGG.2B.158.LN	FGG.2B.130.LC
	M	31	3.1	–	3.2	> 2.2	FGG.0B.732.DN	FGG.2B.138.LN	FGG.2B.158.LN	FGG.2B.130.LC
	D	42	4.2	–	4.2	> 3.2	FGG.0B.742.DN	FGG.2B.138.LN	FGG.2B.158.LN	FGG.2B.130.LC
	D	52	5.2	–	5.2	> 4.2	FGG.2B.752.DN	–	–	FGG.2B.130.LC
	D	62	6.2	–	6.2	> 5.2	FGG.2B.762.DN	–	–	FGG.2B.130.LC
	D	72	7.2	–	7.2	> 6.2	FGG.2B.772.DN	–	–	FGG.2B.130.LC
	D	82	8.2	–	8.2	> 7.2	FGG.2B.782.DN	–	–	FGG.2B.130.LC
	D	92	9.2	8.6	9.2	> 8.2	FGG.2B.792.DN	–	–	FGG.2B.130.LC
	D	99	9.9	8.6	9.9	> 9.2	FGG.2B.799.DN ³⁾	–	–	FGG.2B.132.LC
3B	M	52	5.2	–	5.2	> 4.2	FGG.1B.752.DN	FGG.3B.138.LN	FGG.3B.158.LN	FGG.3B.130.LC
	D	62	6.2	–	6.2	4.9	FGG.3B.762.DN	–	–	FGG.3B.130.LC
	D	72	7.2	–	7.7	> 6.2	FGG.3B.777.DN	–	–	FGG.3B.130.LC
	D	82	8.2	–	9.2	> 7.7	FGG.3B.792.DN	–	–	FGG.3B.130.LC
	D	92	9.2	–	9.2	> 7.7	FGG.3B.792.DN	–	–	FGG.3B.130.LC
	D	10	10.2	–	10.7	> 9.2	FGG.3B.710.DN	–	–	FGG.3B.130.LC
	D	11	11.2	10.2	11.9	> 10.7	FGG.3B.712.DN ³⁾	–	–	FGG.3B.130.LC
	D	12	11.9	10.2	11.9	> 10.7	FGG.3B.712.DN ³⁾	–	–	FGG.3B.132.LC
4B	M	62	6.2	–	6.0	5.1	FGG.2B.762.DN	FGG.4B.138.LN	FGG.4B.158.LN	FGG.4B.130.LC
	M	72	7.2	–	7.0	6.1	FGG.2B.772.DN	FGG.4B.138.LN	FGG.4B.158.LN	FGG.4B.130.LC
	M	82	8.2	–	8.0	7.1	FGG.2B.782.DN	FGG.4B.138.LN	FGG.4B.158.LN	FGG.4B.130.LC
	M	92	9.2	8.6	9.0	8.1	FGG.2B.792.DN	FGG.4B.138.LN	FGG.4B.158.LN	FGG.4B.130.LC
	D	10	10.8	–	10.5	9.1	FGG.4B.710.DN	–	–	FGG.4B.130.LC
	D	12	12.3	–	12.0	10.6	FGG.4B.712.DN	–	–	FGG.4B.130.LC
	D	13	13.8	12.5	13.5	12.1	FGG.4B.713.DN	–	–	FGG.4B.130.LC
	D	15	15.3	12.5	15.0	13.6	FGG.4B.715.DN	–	–	FGG.4B.130.LC
	D	16	16.3	12.5	16.0	15.1	FGG.4B.716.DN ³⁾	–	–	FGG.4B.132.LC
5B	D	11	11.8	–	11.5	9.6	FGG.5B.711.DN	–	–	FGG.5B.130.LC
	D	13	13.8	–	13.5	11.6	FGG.5B.713.DN	–	–	FGG.5B.130.LC
	D	15	15.8	–	15.5	13.6	FGG.5B.715.DN	–	–	FGG.5B.130.LC
	D	17	17.8	–	17.5	15.6	FGG.5B.717.DN ³⁾	–	–	FGG.5B.130.LC
	D	19	19.8	–	19.5	17.6	FGG.5B.719.DN ³⁾	–	–	FGG.5B.130.LC
	D	21	21.8	–	21.5	19.6	FGG.5B.721.DN ³⁾	–	–	FGG.5B.130.LC
	D	23	23.8	21.8	23.5	21.6	FGG.5B.723.DN ³⁾	–	–	FGG.5B.130.LC
	D	25	25.3	21.8	25.0	23.6	FGG.5B.725.DN ³⁾	–	–	FGG.5B.132.LC

Note:

- ¹⁾ For ordering collet separately.
- ²⁾ For ordering an M type collet, a reducer and its reducing cone should also be ordered.
- ³⁾ These collets cannot be used for connector models with collet nut for fitting a bend relief.

All dimensions are in millimeters.

Bend relief collet nut and bend relief

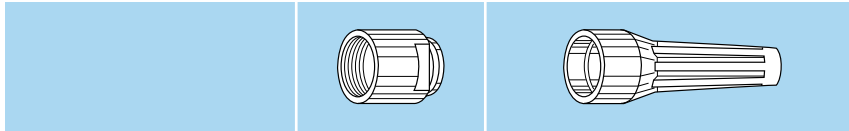

Reference		Collet nut part number	Bend relief to be used ¹⁾	
Type	ø			
2B	M	21 and 31	FFM.2B.132.LC	GMA.0B.●●●●●
	D	42	FFM.2B.130.LC	GMA.2B.●●●●●
	D	52 to 92	FFM.2B.130.LC	GMA.2B.●●●●●
3B	M	52	FFM.3B.131.LC	GMA.1B.●●●●●
	D	62 to 10	FFM.3B.130.LC	GMA.3B.●●●●●
4B	M	62 and 72	FFM.4B.132.LC	GMA.2B.●●●●●
	M	82 and 92	FFM.4B.130.LC	GMA.4B.●●●●●
	D	10 to 15	FFM.4B.130.LC	GMA.4B.●●●●●
5B	D	11 to 15	FFM.5B.130.LC	GMA.4B.●●●●●

Note: ¹⁾ The bend relief is to be ordered separately (see pages 91 and 92).

All dimensions are in millimeters.

T type cable adapter

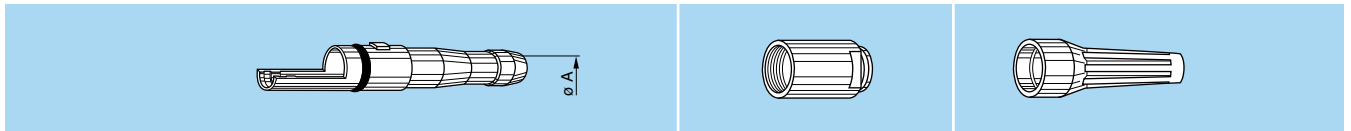

Reference	Type	ø	Adapter ø A	Cable ø		Adapter with gasket part number	Collet nut part number	Bend relief to be used ¹⁾	Note
				max.	min.				
2K	T	46	4.6	4.5	3.6	FGG.2K.846.TNV	FFM.2K.130.LC	GMA.2B.040.D●	●
	T	51	5.1	5.0	4.1	FGG.2K.851.TNV	FFM.2K.130.LC	GMA.2B.045.D●	○
	T	56	5.6	5.5	4.6	FGG.2K.856.TNV	FFM.2K.130.LC	GMA.2B.050.D●	●
	T	61	6.1	6.0	5.1	FGG.2K.861.TNV	FFM.2K.130.LC	GMA.2B.057.R●	○
	T	66	6.6	6.5	5.6	FGG.2K.866.TNV	FFM.2K.130.LC	GMA.2B.060.D●	●
3K	T	46	4.6	4.5	3.6	FGG.3K.846.TNV	FFM.3K.134.LC	GMA.2B.040.D●	●
	T	51	5.1	5.0	4.1	FGG.3K.851.TNV	FFM.3K.134.LC	GMA.2B.045.D●	○
	T	56	5.6	5.5	4.6	FGG.3K.856.TNV	FFM.3K.134.LC	GMA.2B.050.D●	●
	T	61	6.1	6.0	5.1	FGG.3K.861.TNV	FFM.3K.134.LC	GMA.2B.057.R●	○
	T	66	6.6	6.5	5.6	FGG.3K.866.TNN	FFM.3K.134.LC	GMA.2B.060.D●	●
	T	71	7.1	7.0	6.1	FGG.3K.871.TNN	FFM.3K.130.LC	GMA.3B.060.D●	●
	T	76	7.6	7.5	6.6	FGG.3K.876.TNN	FFM.3K.130.LC	GMA.3B.070.D●	●
	T	81	8.1	8.0	7.1	FGG.3K.881.TNN	FFM.3K.130.LC	GMA.3B.070.D●	○
	T	86	8.6	8.5	7.6	FGG.3K.886.TNN	FFM.3K.130.LC	GMA.3B.080.D●	●
	T	91	9.1	9.0	8.1	FGG.3K.891.TNN	FFM.3K.130.LC	GMA.3B.080.D●	●
4K	T	46	4.6	4.5	3.6	FGG.4K.846.TNV	FFM.4K.132.LC	GMA.2B.040.D●	●
	T	51	5.1	5.0	4.1	FGG.4K.851.TNV	FFM.4K.132.LC	GMA.2B.045.D●	●
	T	56	5.6	5.5	4.6	FGG.4K.856.TNV	FFM.4K.132.LC	GMA.2B.050.D●	●
	T	61	6.1	6.0	5.1	FGG.4K.861.TNV	FFM.4K.132.LC	GMA.2B.057.R●	○
	T	66	6.6	6.5	5.6	FGG.4K.866.TNV	FFM.4K.132.LC	GMA.2B.060.D●	●
	T	71	7.1	7.0	6.1	FGG.4K.871.TNV	FFM.4K.133.LC	GMA.3B.060.D●	●
	T	76	7.6	7.5	6.6	FGG.4K.876.TNV	FFM.4K.133.LC	GMA.3B.070.D●	●
	T	81	8.1	8.0	7.1	FGG.4K.881.TNV	FFM.4K.133.LC	GMA.3B.070.D●	○
	T	86	8.6	8.5	7.6	FGG.4K.886.TNV	FFM.4K.133.LC	GMA.3B.080.D●	●
	T	91	9.1	9.0	8.1	FGG.4K.891.TNV	FFM.4K.133.LC	GMA.3B.080.D●	○
	T	96	9.6	9.5	8.6	FGG.4K.896.TNV	FFM.4K.132.LC	GMA.4B.010.D● ²⁾	●
	T	10	10.6	10.5	9.6	FGG.4K.810.TNV	FFM.3K.132.LC	GMA.4B.010.D●	●
	T	11	11.6	11.5	10.6	FGG.4K.811.TNV	FFM.3K.132.LC	GMA.4B.011.D●	●
T	12	12.6	12.5	11.6	FGG.4K.812.TNV	FFM.3K.132.LC	GMA.4B.012.D●	●	
T	13	13.6	13.5	12.6	FGG.4K.813.TNV	FFM.3K.132.LC	GMA.4B.013.D●	●	

Note: ¹⁾ The bend relief is to be ordered separately (see pages 91 and 92).

● First choice alternative ○ Special order alternative

²⁾ Add a short piece of heat-shrink tubing under the bend relief.

T type cable adapter



Reference	Adapter		Cable \varnothing		Adapter with gasket part number	Collet nut part number	Bend relief to be used ¹⁾	Note	
	Type	\varnothing	max.	min.					
5K	T	46	4.6	4.5	3.6	FGG.5K.846.TNV	FFM.5K.132.LC	GMA.2B.040.D●	○
	T	51	5.1	5.0	4.1	FGG.5K.851.TNV	FFM.5K.132.LC	GMA.2B.045.D●	○
	T	56	5.6	5.5	4.6	FGG.5K.856.TNV	FFM.5K.132.LC	GMA.2B.050.D●	○
	T	61	6.1	6.0	5.1	FGG.5K.861.TNV	FFM.5K.132.LC	GMA.2B.057.R●	●
	T	66	6.6	6.5	5.6	FGG.5K.866.TNV	FFM.5K.132.LC	GMA.2B.060.D●	●
	T	71	7.1	7.0	6.1	FGG.5K.871.TNV	FFM.5K.131.LC	GMA.3B.060.D●	●
	T	76	7.6	7.5	6.6	FGG.5K.876.TNV	FFM.5K.131.LC	GMA.3B.070.D●	○
	T	81	8.1	8.0	7.1	FGG.5K.881.TNV	FFM.5K.131.LC	GMA.3B.070.D●	●
	T	86	8.6	8.5	7.6	FGG.5K.886.TNV	FFM.5K.131.LC	GMA.3B.080.D●	○
	T	91	9.1	9.0	8.1	FGG.5K.891.TNV	FFM.5K.131.LC	GMA.3B.080.D●	●
	T	96	9.6	9.5	8.6	FGG.5K.896.TNV	FFM.5K.133.LC	GMA.4B.010.D● ²⁾	○
	T	10	10.6	10.5	9.6	FGG.5K.810.TNV	FFM.5K.133.LC	GMA.4B.010.D●	●
	T	11	11.6	11.5	10.6	FGG.5K.811.TNV	FFM.5K.133.LC	GMA.4B.011.D●	●
	T	12	12.6	12.5	11.6	FGG.5K.812.TNV	FFM.5K.133.LC	GMA.4B.012.D●	●
	T	13	13.6	13.5	12.6	FGG.5K.813.TNV	FFM.5K.133.LC	GMA.4B.013.D●	○
	T	14	14.6	14.5	13.6	FGG.5K.814.TNV	FFM.5K.133.LC	GMA.4B.013.D●	●
	T	15	15.6	15.5	14.6	FGG.5K.815.TNV	FFA.5K.131.LC	heat-shrink tube ³⁾	●
	T	16	16.6	16.5	15.6	FGG.5K.816.TNV	FFA.5K.131.LC	heat-shrink tube	●
	T	17	17.6	17.5	16.6	FGG.5K.817.TNV	FFA.5K.131.LC	heat-shrink tube	●
	T	18	18.6	18.5	17.6	FGG.5K.818.TNV	FFA.5K.134.LC	heat-shrink tube	●
	T	19	19.6	19.5	18.6	FGG.5K.819.TNV	FFA.5K.134.LC	heat-shrink tube	●
	T	20	20.6	20.5	19.6	FGG.5K.820.TNV	FFA.5K.134.LC	heat-shrink tube	●
	T	21	21.6	21.5	20.6	FGG.5K.821.TNV	FFA.5K.132.LC	heat-shrink tube	●
T	22	22.6	22.5	21.6	FGG.5K.822.TNV	FFA.5K.132.LC	heat-shrink tube	●	
T	23	23.6	23.5	22.6	FGG.5K.823.TNV	FFA.5K.132.LC	heat-shrink tube	●	

Note:

- 1) The bend relief is to be ordered separately (see pages 91 and 92).
- 2) Add a short piece of heat-shrink tubing under the bend relief.
- 3) The heat-shrink tube is supplied.

● First choice alternative ○ Special order alternative

All dimensions are in millimeters.



The «variant» position of the reference is used to specify the colour of the shell, the anodized colour according to the table below or the cable group.

Colour of connectors shell made of plastic material

Ref.	Colour
B ¹⁾	white
G ¹⁾	grey

Note: ¹⁾ PSU connector shells are only available in white or grey colours.

Anodized colour

Part number for connector with standard collet nut

Ref.	Anodized colour	Ref.	Anodized colour
A	blue	R	red
J	yellow	T	natural
N	black	V	green

Part number for connector with collet nut for bend relief

Ref.	Anodized colour
L	black
X	natural

Note: Other anodizing colours are available for connectors with collet nut for bend relief. Please consult the factory.

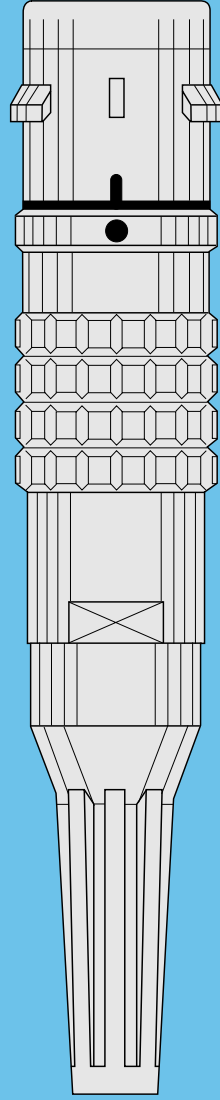
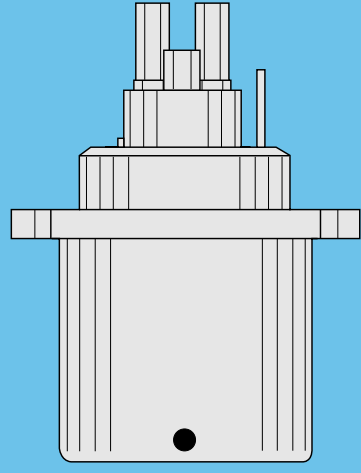

3K.93C SERIES

3K.93C Series

The LEMO 3K.93C connectors with keys (W) were developed to meet the critical requirements of the new generation of digital HDTV cameras.

The main features of this series are as follows:

- Security of the LEMO Push-Pull self-latching system
- Fitted with the standard LEMO F2 fibre optic contacts.
- Conforms to the Japanese ARIB technical report BTA S-1005B, to the ANSI/SMPTE 304 M-1998 and 311M-1998 standards and to the European EBU Technical Recommendation R100-1999.
- Qualified for use in UL approved equipment such as those specified in UL 1419 «Professional Video and Audio Equipment».
- Cabled connectors have obtained the EC Attestation of conformity No: N8 00 03 39058 001 from the German TÜV Product Service.

The 3K.93C series consists of eleven models which will accept cables specific to this application. It includes the HEAVY DUTY line with stainless steel shells that is guaranteed to at least 20,000 mating cycles and offer more resistance to heavy wear conditions.

Interconnections

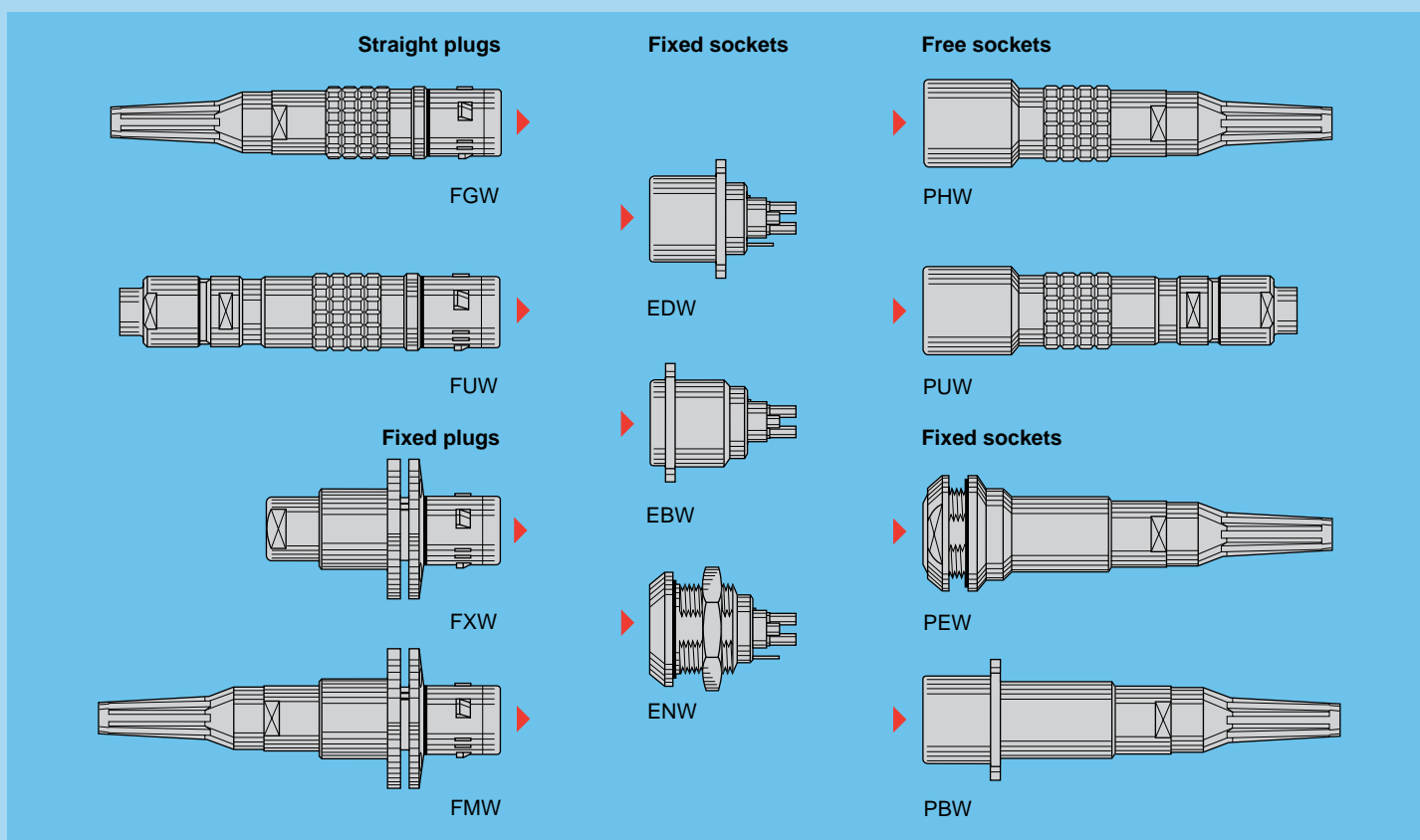

Model Description

- | | | |
|--|---|--|
| FGW Straight plug, keys (W), cable adapter, with bend relief | EDW Fixed socket with rear square flange (4 holes fixing), keys (W), and earthing tag | PUW Free socket, keys (W), cable collet adapter and long shell for fitting a bend relief with cap (with enhanced screen efficiency) |
| FMW Fixed plug with round flange (4 holes fixing), keys (W), cable adapter, with bend relief | ENW Fixed socket, nut fixing, keys (W), and earthing tag | |
| FUW Straight plug, keys (W), cable collet adapter and long shell for fitting a bend relief with cap (with enhanced screen efficiency) | PBW Fixed socket with rear square flange (4 holes fixing), keys (W), cable adapter, with bend relief | |
| FXW Fixed plug with round flange (4 holes fixing), keys (W) | PEW Fixed socket, nut fixing, keys (W), cable adapter, with bend relief (back panel mounting) | |
| EBW Fixed socket with front square flange (4 holes fixing), keys (W) | PHW Free socket, keys (W), cable adapter, with bend relief | |

Part Section Showing Internal Components

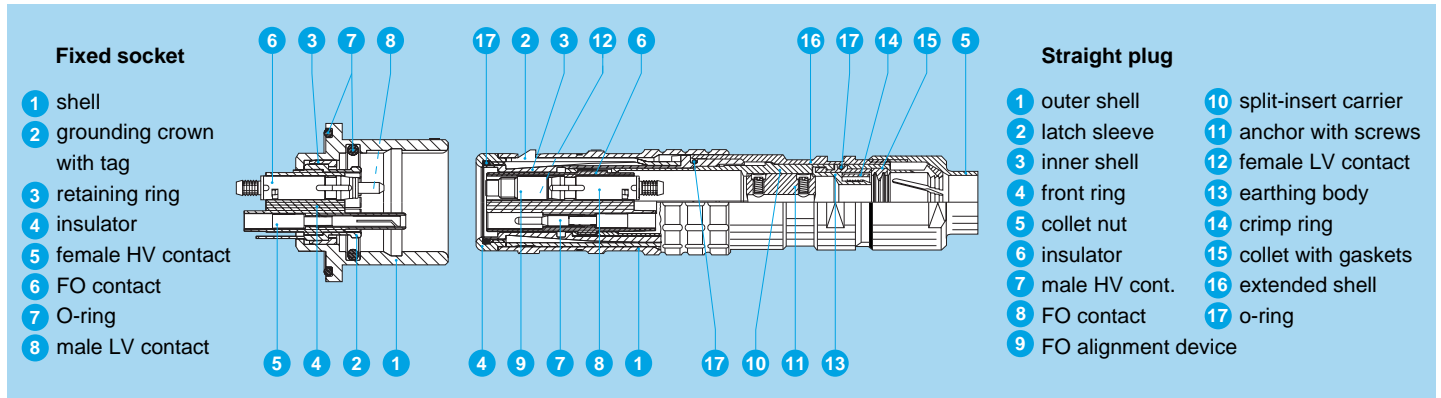

Technical Characteristics

Materials and Treatments

Component	Material (Standard)	Surface treatment (µm)								
		chrome			nickel		gold			
		Cu	Ni	Cr	Cu	Ni	Cu	Ni	Au	
Outer shell, collet nut and oversized collet	Brass (UNS C 38500)	0.5	3	0.3	–	–	–	–	–	
	Stainless steel (AISI 303)	without treatment								
Grounding crown	Special brass	–	–	–	0.5	3	–	–	–	
	Stainless steel (AISI 416)	without treatment								
Latch sleeve	Special brass	0.5	3	0.3	–	–	–	–	–	
	Stainless steel (AISI 416)	without treatment								
Locking washer	Bronze (UNS C 52100)	–	–	–	0.5	3	–	–	–	
Hexagonal or round nut	Brass (UNS C 38500)	–	–	–	0.5	3	–	–	–	
Male crimp contact	Brass (UNS C 34500)	–	–	–	–	–	0.5	3	1.0	
Female crimp contact	Bronze (UNS C 54400)	–	–	–	–	–	0.5	3	1.5	
Clips	Cu-Be (FS QQ-C-530)	without treatment								
Insulator	PEEK	–								
Crimping tube	Copper (UNS C 18700)	–	–	–	0.5	3	–	–	–	
Other metallic components	Brass (UNS C 38500)	–	–	–	0.5	3	–	–	–	
	Stainless steel (AISI 303)	without treatment								
O-ring and gaskets	Silicone MQ/MVQ, FPM/FKM (Viton®) or Nitril NBR	–								

Notes: Standards for surface treatment are as follows:
 – Chrome-plated: FS QQ-C-320B;
 – Nickel-plated: FS QQ-N-290A, or MIL-C-26074C;
 – Gold-plated: ISO 4523

Mechanical and Environmental

Characteristic	Value	Standard
Mating durability (Brass+Brass)	10,000 cycles	IEC 61300-02-02
Mating durability (Brass+Stainless steel)	8,000 cycles	IEC 61300-02-02
Mating durability (Stainless steel+St. steel)	20,000 cycles	IEC 61300-02-02
Damp heat steady state	Up to 95% at 60°C	IEC 61300-02-19
High temperature	+80°C	IEC 61300-02-18
Low temperature	-40°C	IEC 61300-02-17
Temperature cycling	-55°C + 90°C	
Cable retention	1000 N	IEC 61300-02-04
Impact (Method A)	2 m onto concrete floor	IEC 61300-02-12
Shock (3 cycles in 2 directions)	100 g, 10-50 ms; 20 g 6-9 ms	IEC 61300-02-09
Vibration (7 cycles)	Diagram 2 page 111	IEC 61300-02-01
Water resistance (Depth of 1.8 for 48 h)	IP 68	IEC 60529
Salt spray corrosion test ¹⁾	> 144h	IEC 60512-6 test 11f

Optical

Characteristic	Value	Standard	Method
Average insertion loss fibre 9/125 µm	0.10 dB	IEC 61300-03-04	Insertion Method B
Return loss fibre 9/125 µm (UPC)	≥45 dB	IEC 61300-03-06	Branching Device Met.
Return loss fibre 9/125 µm (Hand polish)	~30 dB	IEC 61300-03-06	Branching Device Met.

Electrical

Characteristic	Value	Standard	Section
Insulation resistance	> 10 ¹² Ω	IEC 60512-2	test 3a
Shell electrical continuity	< 1.6 mΩ	IEC 60512-2	test 2f
Contact resistance (signal)	< 4.8 mΩ	IEC 60512-2	test 2a
Contact resistance (power)	< 3.6 mΩ	IEC 60512-2	test 2a
Radiated emission ¹⁾	freq. 30-220 MHz	< 30 dBµV/m	EN 55022 class B
	freq. 220-1000 MHz	< 37 dBµV/m	EN 55022 class B

Note: ¹⁾ for FUW and PUW model only.
 Detailed characteristics are presented on pages 109 to 111.

Note: ¹⁾ the outer shells are in chrome-plated brass (Cr1).

Alignment Key and Polarized Keying Systems

	Model	No of keys	Angles	
	●●W	5	α	95°
			β	115°
			γ	20°
			δ	30°

Recommended cables

Cable group	Type	Utilisation	Sheath outer \varnothing
1	2SM-8.6-37.5	outdoor	8.6 ± 0.3
2	2SM-9.2-37.5	outdoor	9.2 ± 0.3
3	2SM-12-15	long distances	12.0 ± 0.4
4 ¹⁾	2SM-16-37.5	indoor	16.0 ± 0.5

Note: ¹⁾ The outer sheath shall be removed for assembly.

Part Number Example

A different part number structure is applicable for each of the following product types:

- Plugs and sockets for assembly onto cables
- Fixed plugs and sockets.

Straight plug with cable adapter

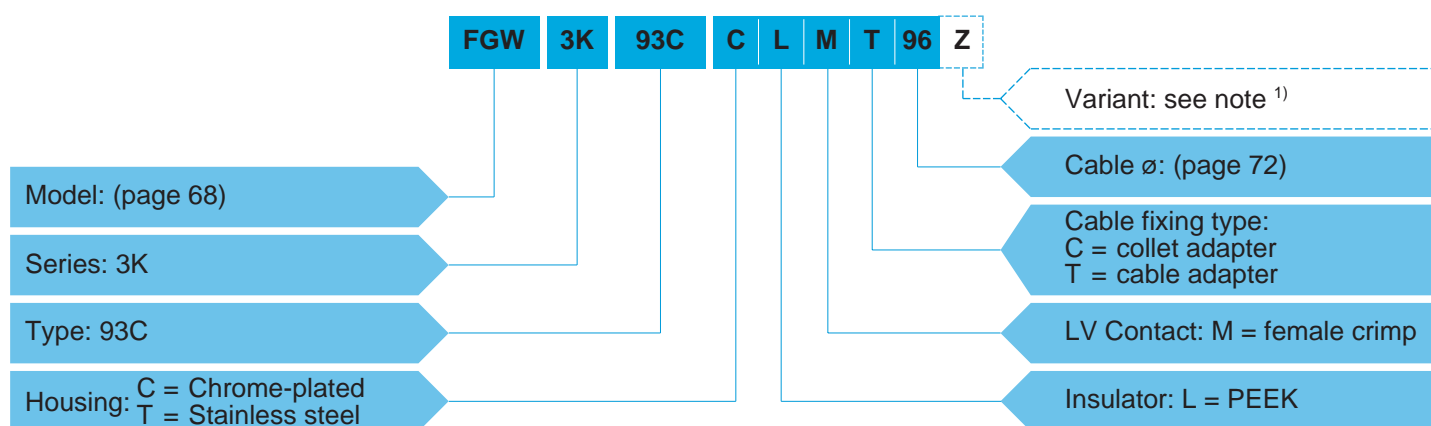

FGW.3K.93C.CLMT96Z = Straight plug with keys (W), 3K series, mixed type to accept 2 F2 type fibre optic contacts, 2 power and 2 signal electrical contacts, chrome-plated brass housing, PEEK insulator, female crimp signal contacts, cable fixing type T for 9.2 mm diameter cable, and nut for fitting a bend relief.

Fixed socket

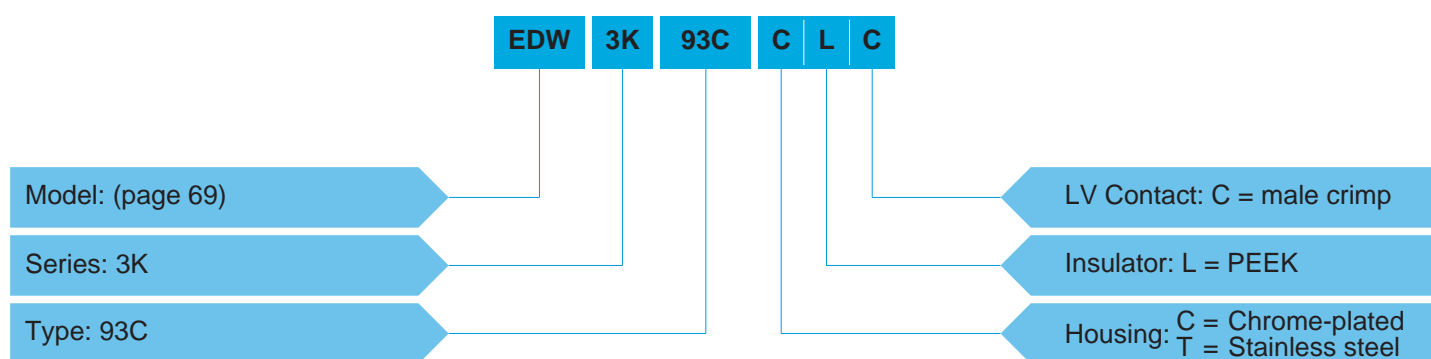

EDW.3K.93C.CLC = Fixed socket with rear square flange, keys (W), 3K series, mixed type to accept 2 F2 type fibre optic contacts, 2 power and 2 signal electrical contacts, chrome-plated brass housing, PEEK insulator, male crimp signal contacts.

The fibre optic contacts must be ordered separately (see page 79).

Note: ¹⁾ The «Variant» position in the reference is used to indicate the presence of a collet nut for fitting the bend relief. For models with the «T» type of cable adapter the «Z» should always be indicated and a bend relief can be ordered separately as indicated in the «Accessories» section. An order for a connector with bend relief should thus include two part numbers.

Model - Series

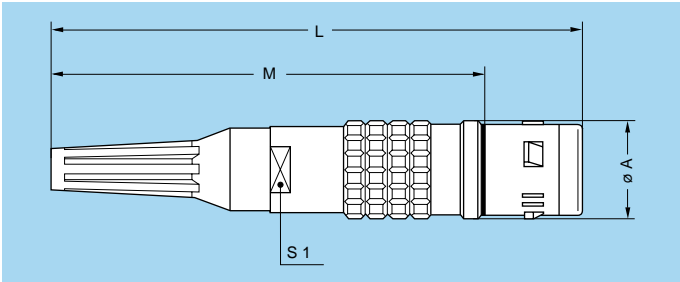
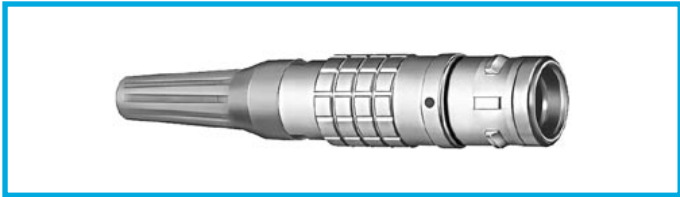

FGW.3K Straight plug, keys (W), cable adapter, with bend relief

Part Number	Cable group	Dimension (mm)			
		A	L	M	S1
FGW.3K.93C.CLMT90Z	1	19	101	81	15
FGW.3K.93C.CLMT96Z	2, 4	19	101	81	15
FGW.3K.93C.CLMT12Z	3	19	135	115	20

Note: The bend relief must be ordered separately (see page 91). The overall length dimension is with Desmopan bend relief (see pages 91 and 92).

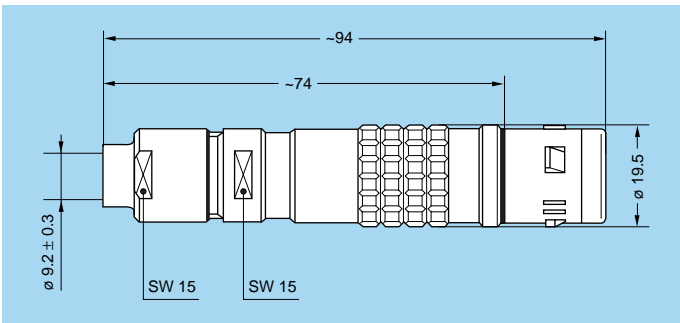
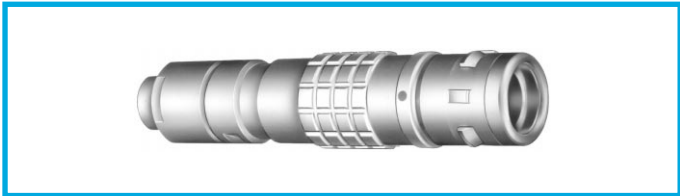

FUW.3K Straight plug, keys (W), cable collet adapter and long shell for fitting a bend relief with cap (with enhanced screen efficiency)

Part Number	Cable group	Note
FUW.3K.93C.CLMC96	2, 4	-
FUW.3K.93C.TLMC96	2, 4	HEAVY DUTY LINE

Note: The bend relief with cap must be ordered separately (see page 91).

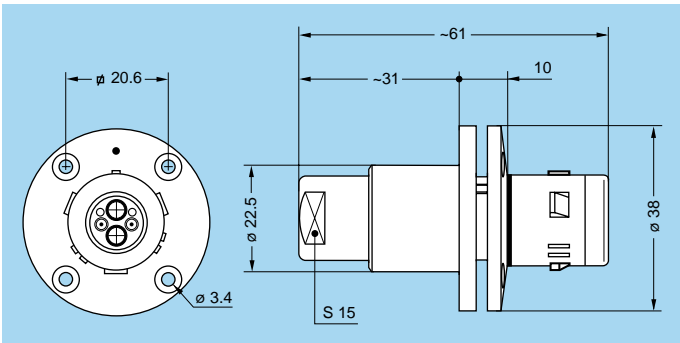
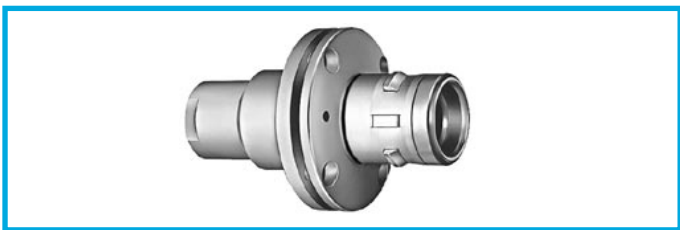

FXW.3K Fixed plug with round flange (4 holes fixing), keys (W)

Part Number	Note
FXW.3K.93C.CL	-
FXW.3K.93C.TLM	HEAVY DUTY LINE

Panel cut-out (page 76)

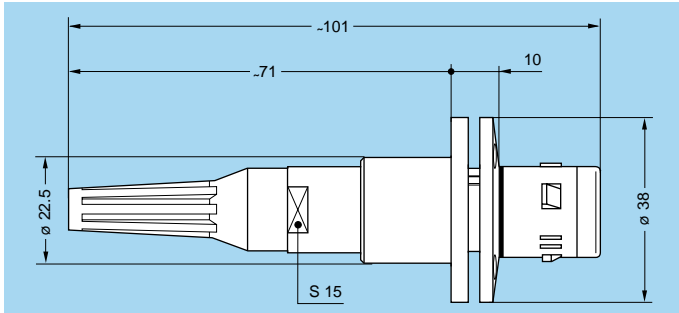
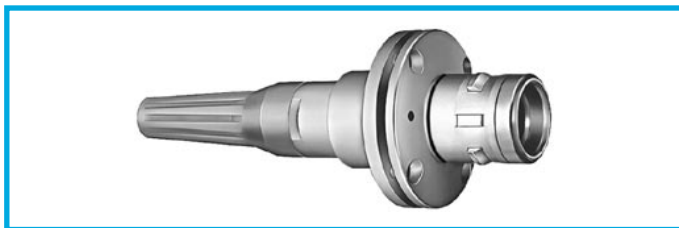

FMW.3K Fixed plug with round flange (4 holes fixing), keys (W), cable adapter, with bend relief

Part Number	Cable group	Note
FMW.3K.93C.CLMT90Z	1	-
FMW.3K.93C.CLMT96Z	2, 4	-
FMW.3K.93C.TLMT96Z	2, 4	HEAVY DUTY LINE

Panel cut-out (page 76)

Note: See FXW drawing for front view. The bend relief must be ordered separately (see page 91). The overall length dimension is with Desmopan bend relief (see pages 91 and 92).

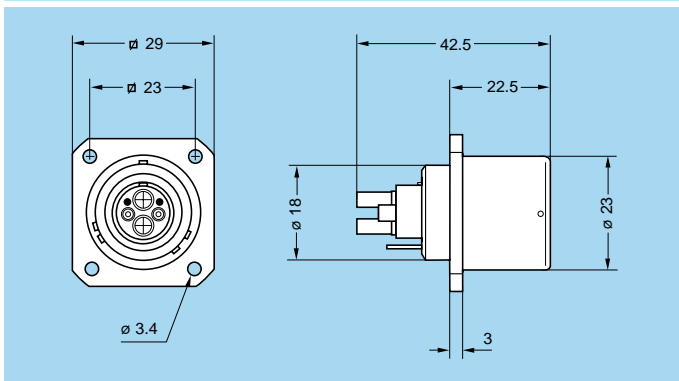

EDW.3K Fixed socket with rear square flange (4 holes fixing), keys (W), and earthing tag

Part Number	Note
EDW.3K.93C.CLC	-
EDW.3K.93C.TLC	HEAVY DUTY LINE

Panel cut-out (page 76)

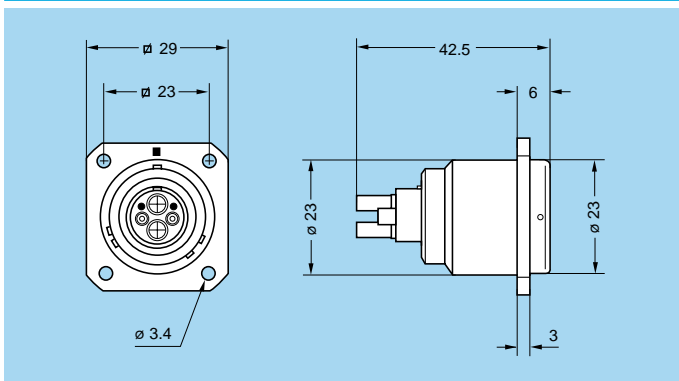

EBW.3K Fixed socket with front square flange (4 holes fixing), keys (W)

Part Number
EBW.3K.93C.CLC

Panel cut-out (page 76)

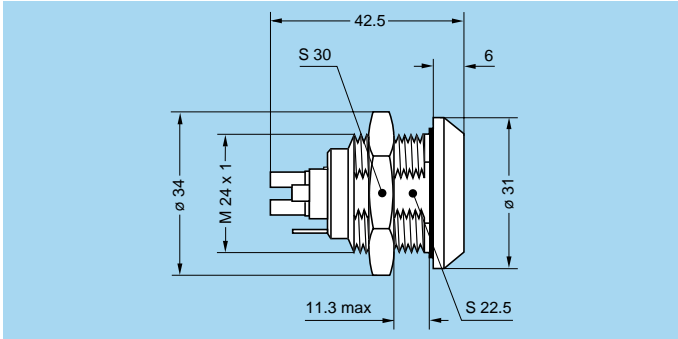

ENW.3K Fixed socket, nut fixing, keys (W), and earthing tag

Part Number

ENW.3K.93C.CLC

Panel cut-out (page 76)

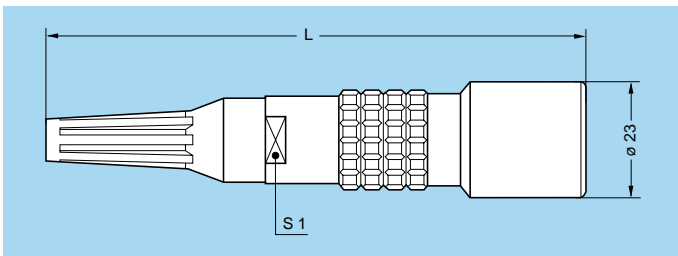
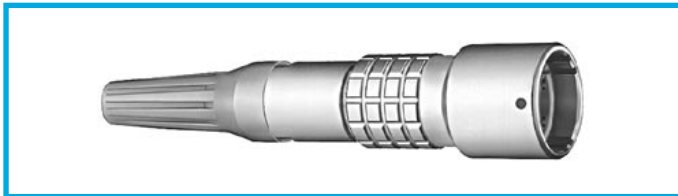

PHW.3K Free socket, keys (W), cable adapter, with bend relief

Part Number	Cable group	Dimension (mm)	
		L	S1
PHW.3K.93C.CLCT90Z	1	105	15
PHW.3K.93C.CLCT96Z	2, 4	105	15
PHW.3K.93C.CLCT12Z	3	139	20

Note: The bend relief must be ordered separately (see page 91). The overall length dimension is with Desmopan bend relief (see pages 91 and 92).

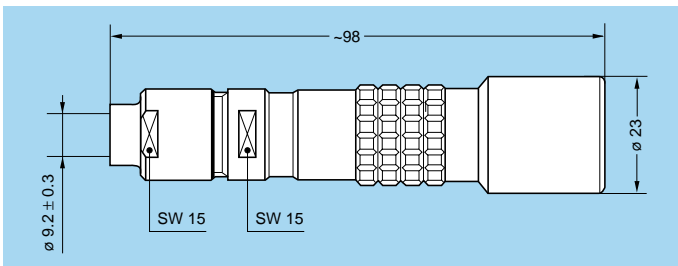
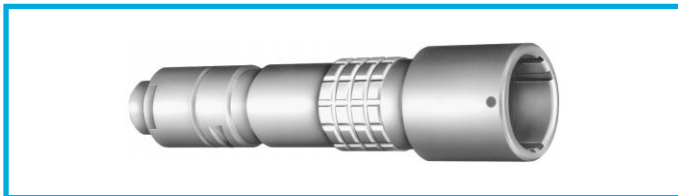

PUW.3K Free socket, keys (W), cable collet adapter and long shell for fitting a bend relief with cap (with enhanced screen efficiency)

Part Number	Cable group	Note
PUW.3K.93C.CLCC96	2, 4	–
PUW.3K.93C.TLCC96	2, 4	HEAVY DUTY LINE

Note: The bend relief with cap must be ordered separately (see page 91).

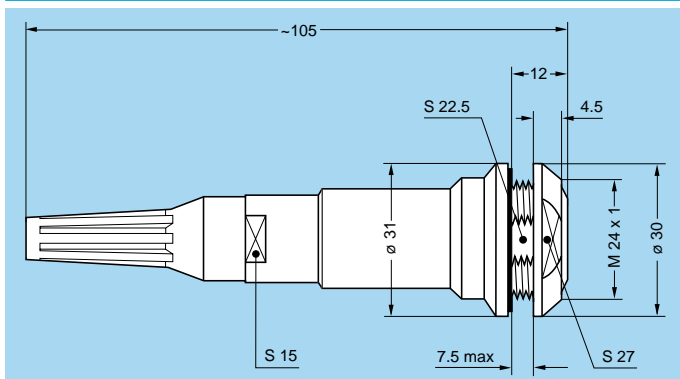
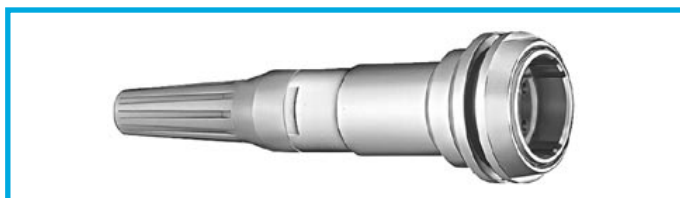

PEW.3K Fixed socket, nut fixing, keys (W), cable adapter, with bend relief (back panel mounting)

Part Number	Cable group	Note
PEW.3K.93C.CLCT90Z	1	-
PEW.3K.93C.CLCT96Z	2, 4	-
PEW.3K.93C.TLCT96Z	2, 4	HEAVY DUTY LINE

Panel cut-out (page 76)

Note: The bend relief must be ordered separately (see page 91). The overall length dimension is with Desmopan bend relief (see pages 91 and 92).

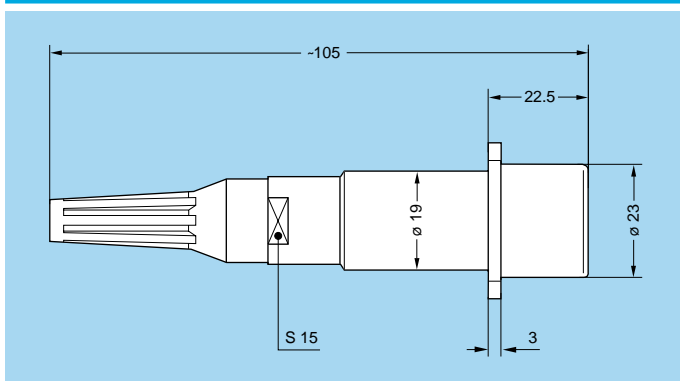
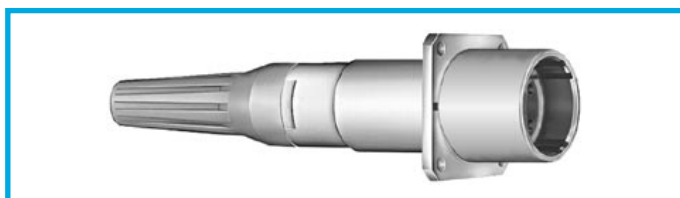

PBW.3K Fixed socket with rear square flange (4 holes fixing), keys (W), cable adapter, with bend relief

Part Number	Cable group
PBW.3K.93C.CLCT90Z	1
PBW.3K.93C.CLCT96Z	2, 4

Panel cut-out (page 76)

Note: See EDW drawing for front view. The bend relief must be ordered separately (see page 91). The overall length dimension is with Desmopan bend relief (see pages 91 and 92).

Types

Socket insulator	Plug insulator	Reference	Fibre optic contact		Electrical crimp contacts										
			Fibre optic F2 No	Contact type for plug	Fibre core/cladding (µm)	Ferrule bore inside ø (µm)	No of contacts	Contact function	Contact type for plug	Contact ø A (mm)	AWG range	Creepage distance and air clearance (mm)	Working voltage (V rms)	Test voltage (V rms)	Rated current (A)
		93C	2	fem.	9/125	125	2	signal	L.V. fem.	0.9	20-24	-	≤42	1000	3
							2	power	H.V. male	1.3	14-18	>6.5	≤600	2250	10

Fibre Optic Contact

FFS.F2 Male F2 Fibre Optic Contact

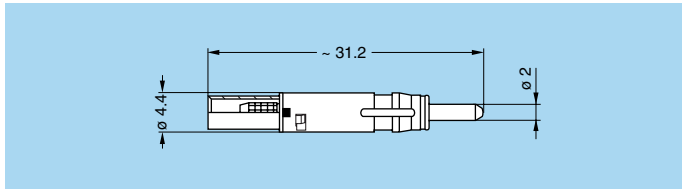
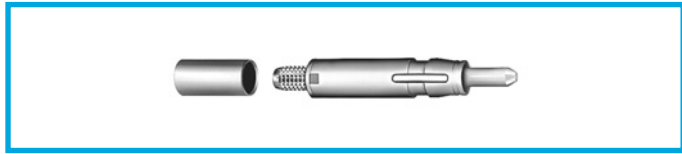

Part number	Models
FFS.F2.BA2.LCT10	PHW, PEW, PBW, PUW
FFS.F2.BA2.LCE30	EDW, ENW, EBW

PSS.F2 Female F2 Fibre Optic Contact

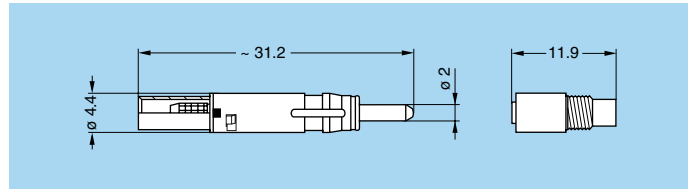
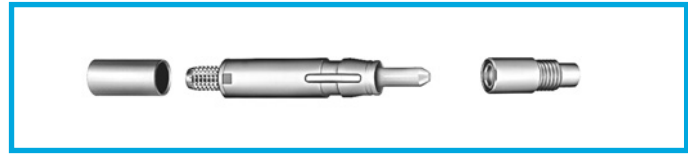

Part number	Models
PSS.F2.BA2.LCT10	FGW, FMW, FUW
PSS.F2.BA2.LCE30	FXW

Note: The above contacts are fitted with a 125 micron bore ferrules. If as an alternative 126 micron bore ferrule is required the «BA2» in the part number should be replaced with the reference «BB2».

Accessories

Cable adapter type «T» for FGW, FMW, PHW, PEW and PBW

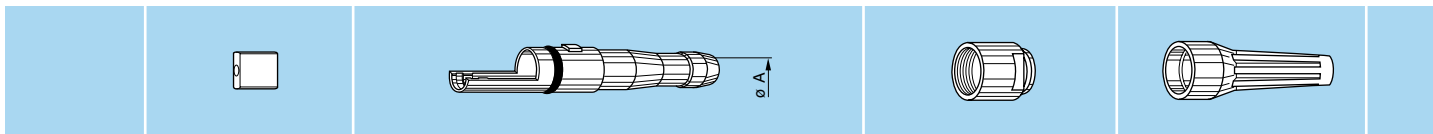

Reference Type	Part number of the anchor with screws	Adapter ø A	Cable ø		Part number of the adapter with gasket	Part number of the collet nut	Bend relief to be used ¹⁾	Cable group
			max.	min.				
T 90	FGW.3K.145.ZZA	9.1	9.0	8.1	FGW.3K.890.TNN	FFM.3E.130.●●	GMA.3B.080.DN	1
T 96	FGW.3K.146.ZZA	9.6	9.5	8.6	FGW.3K.896.TNN	FFM.3K.131.●●	GMA.3B.090.DN	2, 4
T 12	FGW.3K.147.ZZA	12.6	12.5	11.6	FGW.3K.812.TNV	FFM.3K.132.●●	GMA.4B.011.DN	3

Note: ¹⁾ The last letter «N» on the part number indicates black colour of the bend relief. For ordering a bend relief with another colour see table on page 92 and replace the letter «N» by the letter of the colour required.

Collet adapter type «C» for FUW and PUW

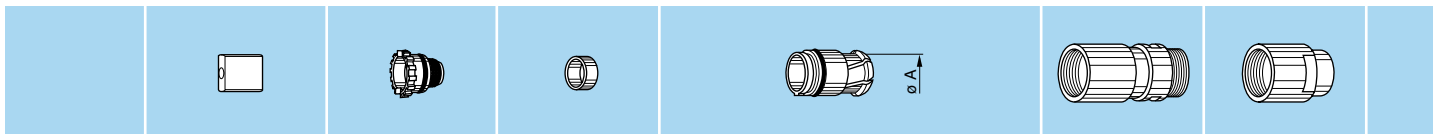

Reference Type	Part number of the anchor with screws	Part number of earthing body with o-ring	Part number of crimp ring	Collet ø A	Cable ø		Part number of collet with gaskets	Part number of extended shell	Part number of the collet nut	Cable group
					max.	min.				
C 96	FGW.3K.146.ZZA	FFS.3K.130.LNV	FFS.3K.160.DN	9.6	9.5	8.6	FUW.3K.796.ZZS	FUW.3K.137.●●	FUW.3K.130.●●	2, 4

Note:
 ●● = LC for chrome-plated brass version
 ●● = AZ for stainless steel version

All dimensions are in millimeters.

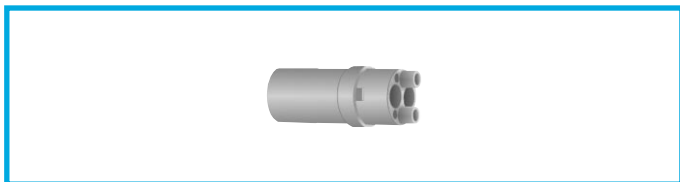

Insulator for plug

Part number	Contact type	
	Signal	Power
EGW.3K.444.EL	Female	Male

Note: Insulator should be ordered as replacement item.

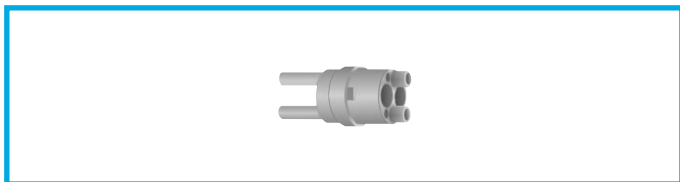

Insulator for socket

Part number	Contact type	
	Signal	Power
FGW.3K.344.EL	Male	Female

Note: Insulator should be ordered as replacement item.

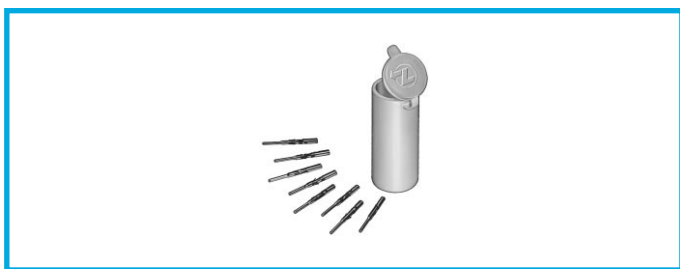

Crimp contacts

∅ Contact LV	Contact function	Contact part number	
		Male	Female
0.9	Signal	FGG.3B.560.ZZC	EGG.3B.660.ZZM
1.3	Power 1)	FGW.3K.565.ZZC	EGW.3K.666.ZZM

Note: 1) Power contacts are special with an oversized crimp barrel. Crimp contacts should be ordered as replacement items.

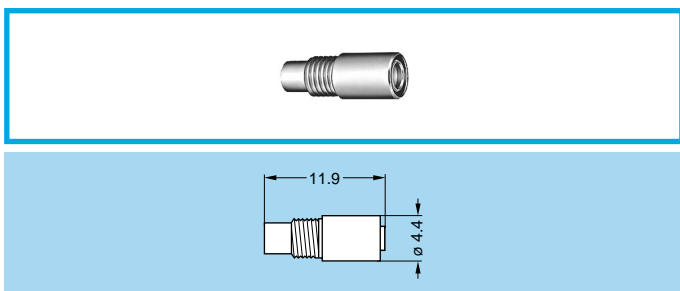

PSS Alignment device for F2 fibre optic contacts

Part number
PSS.F2.290.NZZ

Note: Alignment device should be ordered as replacement item.



GMF.3K Bend relief with cap for FUW plug

Part number
GMF.3K.085.EANZ

● Material: black EPDM

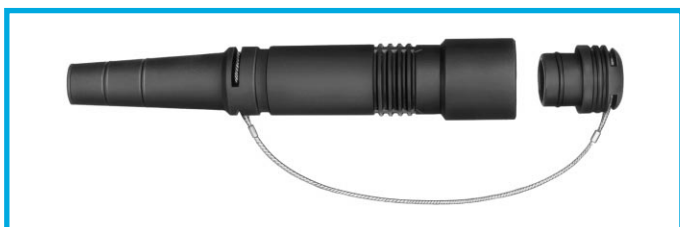

GMP.3K Bend relief with cap for PUW free socket

Part number
GMP.3K.085.EANZ

● Material: black EPDM

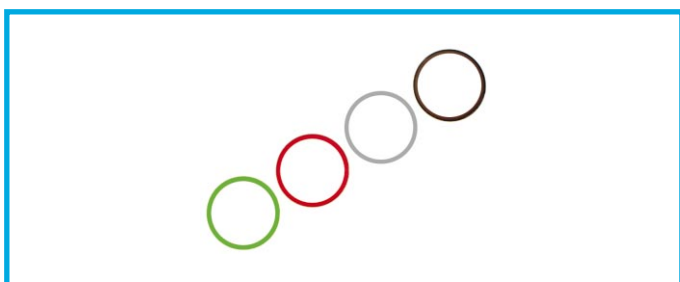

GMF.3K Coloured ring for bend relief with cap

Part number	Colour
GMF.3K.265.RG	grey
GMF.3K.265.RN	black
GMF.3K.265.RR	red
GMF.3K.265.RV	green

● Material: Silicone

Tooling

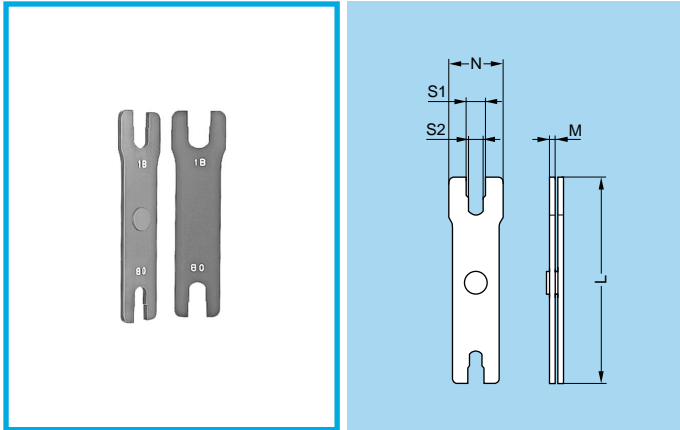

DCP Spanner for tightening collet nut

Part number	Series	Dimensions (mm)				
		L	M	N	S1	S2
DCP.91.023.TN	2K	115	3.0	30	13.1	12.1
	3K	115	3.0	35	15.1	14.1

- Material: Blackened steel



DPF Pliers for assembling plugs or free sockets

Part number	Dimensions (mm)	
	A	B
DPF.91.033.TA	18	23
Model	plugs	free sockets

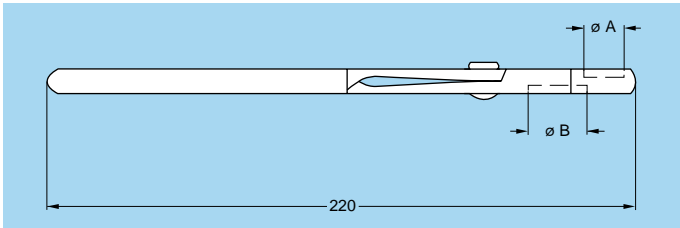

Example for use

The plug or socket end must be held in the pliers while the nut is tightened with the spanner.

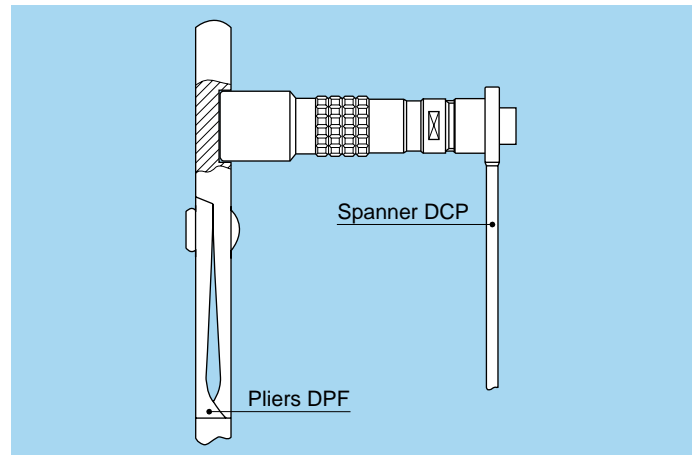
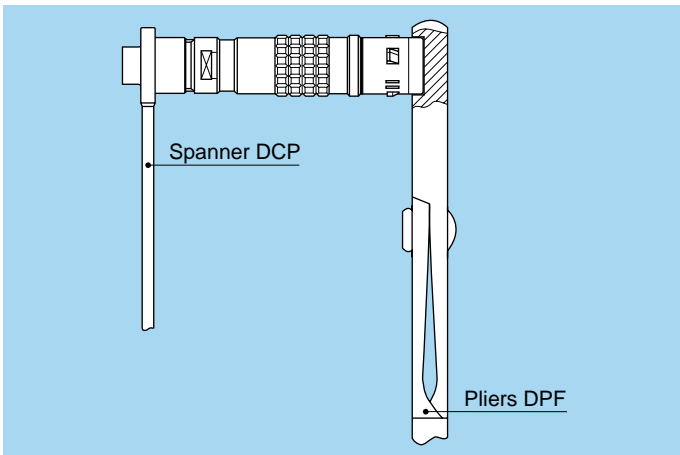

DPD Crimping tool for screen crimping on FUW and PUW

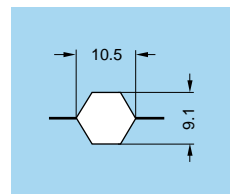

Part number
DPD.99.010.5K

Fibre Optic Tooling

The full range of tools for terminating fibre optic contacts is shown on pages 103 to 106.

Crimping Tools for Electrical Contacts

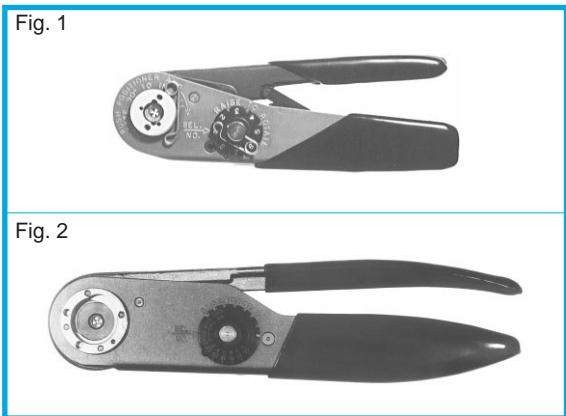

Manual crimping tools

Supplier	Part number	
	signal contacts ø 0.9	power contacts ø 1.3
LEMO	DPC.91.701.V ¹⁾	DPC.91.101.A ²⁾
DANIELS	MH860 ¹⁾	AF8 ²⁾
BALMAR	23-000	55-000
BUCHANAN	616336 ¹⁾	615708 ²⁾

1) According to specification MIL-C-22520/7-01.
2) According to specification MIL-C-22520/1-01.

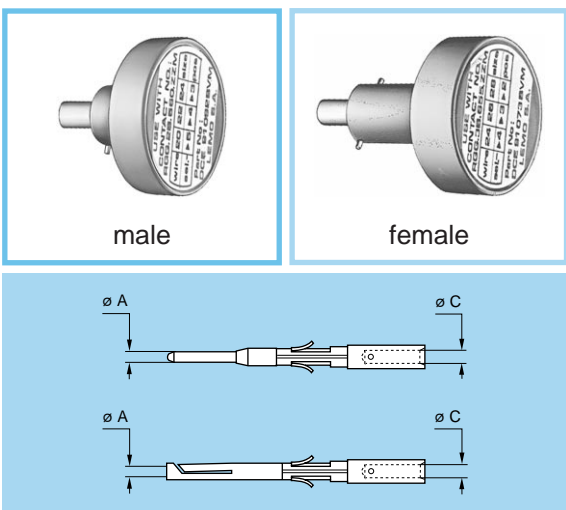

DCE Positioners for signal contacts ø 0.9 mm

Contacts dimensions ø A ø C		Conductor AWG	Selector Pos.	Positioners part number	
				For male contact	For female contact
0.9	1.1	20-22-24	6-5-5	DCE.91.093.BVC	DCE.91.093.BVM

Note: These positioners are suitable for use with both manual and pneumatic crimping tools according to the MIL-C-22520/7-01 standard.

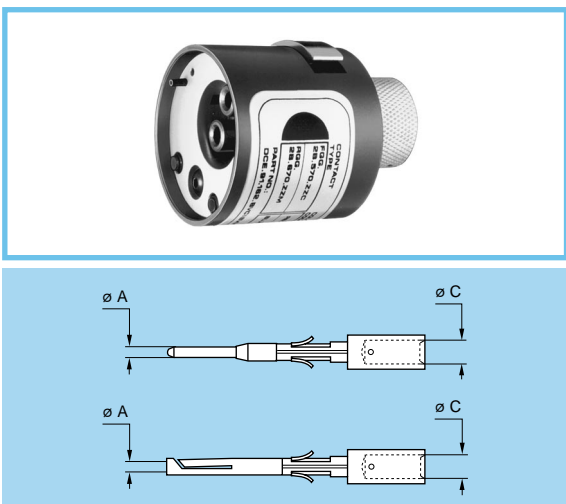

DCE Turret for power contacts ø 1.3 mm

Power contacts are special with an oversized crimp barrel.

Contacts dimensions ø A ø C		Conductor AWG	Selector Pos.	Positioners part number
				For male and female contact
1.3	1.9	14-16-18	7-6-5	DCE.91.133.BVCW

Note: These turrets can be used with manual crimping tool according to MIL-C-22520/1-01 standard.

Termination Instruction



Part Number	Models
DOC.FO.W3K.93CO	All

Panel Cut-Outs

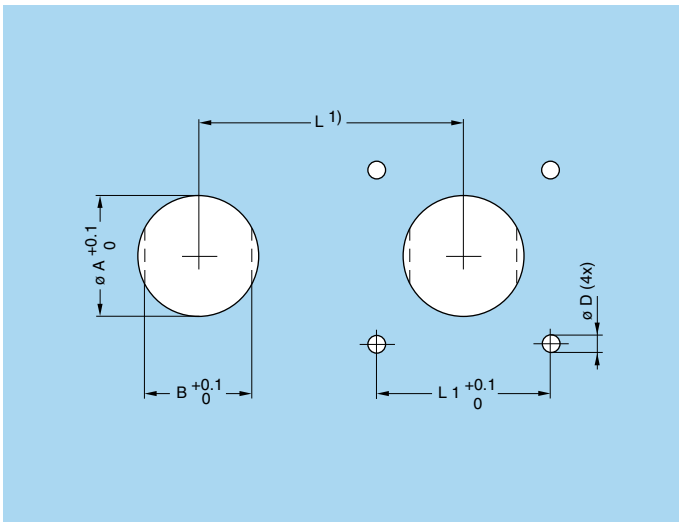

Models	Dimension (mm)				
	A	B	D	L	L1
FMW, FXW	22.6	–	3.2 or M3	39	20.6
EBW	23.1	–	3.2 or M3	30	23.0
EDW	18.1	–	3.2 or M3	30	23.0
ENW, PEW	24.2	22.6	–	32	–
PBW	19.2	–	3.2 or M3	30	23.0

Note: ¹⁾ Minimum distance between two neighbouring components.

Mounting torque

Series	Torque (Nm)	
	Nut	Screws
3K	12	1 to 2 ¹⁾

Note: ¹⁾ Depends on screw material selected. The values shown in the table above are the maximum torque for each connector type.

F1 Fibre Optic Contact

Introduction

The F1 type contact is designed for fitting into multi fibre or mixed fibre optical/electrical connectors from the 2B to 5B, 2K to 5K series.

Its main features are as follows:

- Simple and proven construction with a metallic or ceramic ferrule
- Polishing with specific tooling ensuring a minimum gap between fibres which are not in physical contact
- After mounting on the cable, the contact is installed in the main connector insulator, and retained with a metallic clip.

This contact is suitable for use with multi-mode fibres in Si/Si or plastic, ranging in sizes from 100/140 to 1500 μm .

Part Section Showing Internal Components

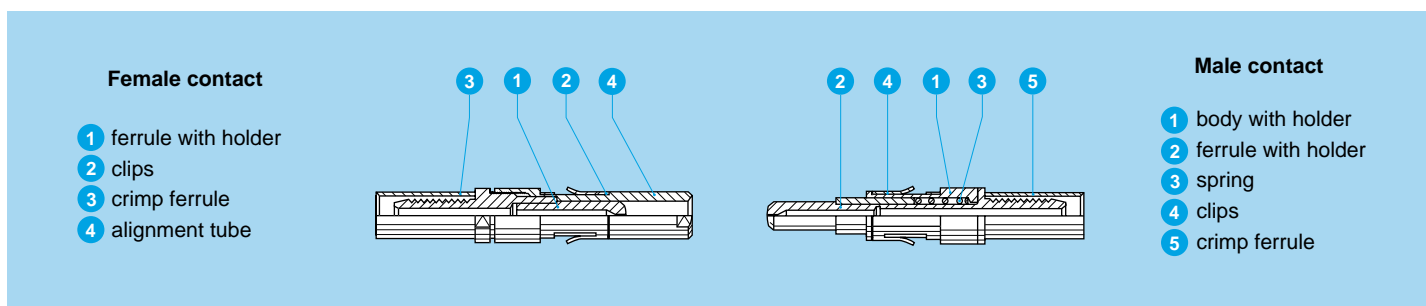

Technical Characteristics

Material and treatment of the Fibre Optic Contact

Component	Material	Surface treatment (μm)	
		Cu	Ni
Body and holder	Alloy CuNiZn	without treatment	
Ferrule	Alloy CuNiZn or ceramic	without treatment	
Spring	Stainless steel	without treatment	
Clip	Cu-Be	without treatment	
Crimp ferrule	Cu 99	0.5	3
Alignment tube	Alloy CuNiZn	without treatment	

Mechanical and Environmental

Characteristic	Value	Standard
Mating durability	1000 cycles	IEC 61300-02-02
Damp heat steady state	up to 95 % at 60°C	IEC 61300-02-19
High temperature	+80°C	IEC 61300-02-18
Low temperature	-40°C	IEC 61300-02-17
Cable retention	100 N	IEC 61300-02-04

Optical

Characteristic	Value	Standard	Method
Average insertion loss fibre 200/230 μm	1.13 dB	IEC 61300-03-04	Insertion Method B

Note: Detailed characteristics are presented on pages 109 to 111.

Part Number Example

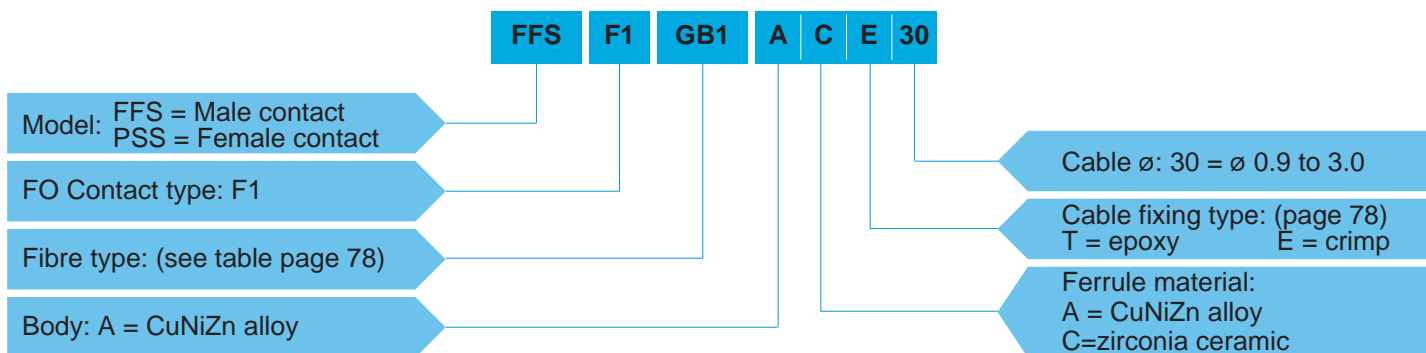

FFS.F1.GB1.ACE30 = Male F1 type fibre optic contact, ferrule bore diameter of 235 μm , ferrule made of zirconia ceramic, crimp type cable fixing for a cable diameter of 0.9 mm to 3.0 mm.

Model - FO Contact Type

FFS.F1 Male F1 Fibre Optic Contact

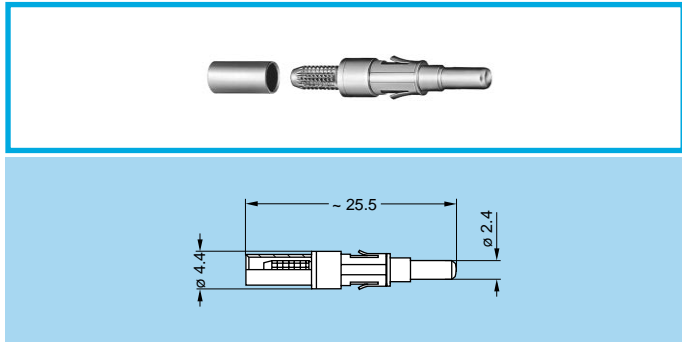

PSS.F1 Female F1 Fibre Optic Contact

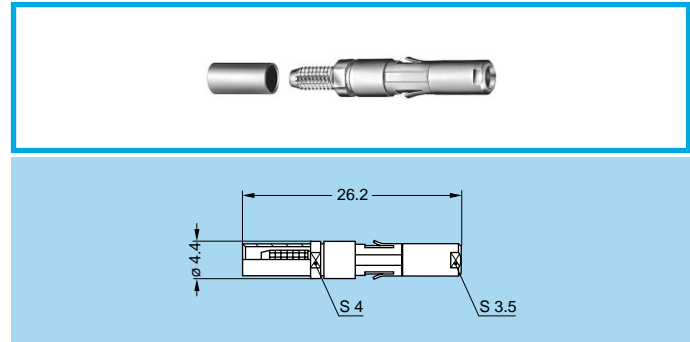

Fibre Type

The choice of the ferrule hole diameter is dependent upon the fibre cladding size. LEMO offers a range of ferrule hole diameters to suit the users' specific requirements.

Reference	Core/cladding \varnothing (μm)	Ferrule hole \varnothing (μm)	Ferrule material	Material ref.	Fibre type	Cable fixing type	Note
FB1	100/140	144	Ceramic	C	Silica	E	●
GA1	200/230	230	Ceramic	C	HCS	E	○
GB1	200/230	235	Ceramic	C	HCS	E	●
HA1	300/330	330	Ceramic	C	HCS	E	○
HB1	300/330	335	Ceramic	C	HCS	E	●
JA1	400/430	430	Metal	A	HCS	E	○
JB1	400/430	435	Metal	A	HCS	E	●
KA1	600/630	630	Metal	A	HCS	E	○
KB1	600/630	640	Metal	A	HCS	E	●
LA1	800/830	830	Metal	A	HCS	E	○
LB1	800/830	845	Metal	A	HCS	E	●
MA1	1000/1035	1035	Metal	A	HCS	E	○
MB1	1000/1035	1050	Metal	A	HCS	E	●
NA1	500	500	Metal	A	Polymer	E	○
NB1	500	550	Metal	A	Polymer	E	●
PA1	750	750	Metal	A	Polymer	E	○
PB1	750	825	Metal	A	Polymer	E	●
RA1	1000	1000	Metal	A	Polymer	E	○
RB1	1000	1100	Metal	A	Polymer	E	●
RK1	1400	1430	Metal	A	Polymer	E	●
SA1	1500	1500	Metal	A	Polymer	T	○
SB1	1500	1650	Metal	A	Polymer	T	●
TA1	200/380	380	Metal	A	PCS	E	○
TB1	200/380	410	Metal	A	PCS	E	●
VA1	300/440	440	Metal	A	PCS	E	○
VB1	300/440	475	Metal	A	PCS	E	●
WA1	600/750	750	Metal	A	PCS	E	●
WB1	600/750	810	Metal	A	PCS	E	●

● First choice alternative
○ Special order alternative

F2 Fibre Optic Contact

Introduction

The F2 type contact is designed for fitting into single fibre 0K series, multi fibre connectors or mixed fibre optical/electrical connectors from 2B to 5B, 2K to 5K series.

Its main features are as follows:

- Assembly uses pre-domed ceramic ferrules
- Simple and fast polishing ensuring the physical contact of the fibre end face
- After mounting on the cable, the contact is very easily installed in the main connector insulator, the particular shape of the contact body retains it in the insulator
- Unique cable assembly independent of the connector shell
- The alignment tube can be easily removed in order to clean the fibre end face.

This contact makes it possible to use single fibre cables with single-mode or multi-mode fibres of the following sizes; 9/125, 50/125, 62.5/125, 100/125 and 100/140 μm .

Part Section Showing Internal Components

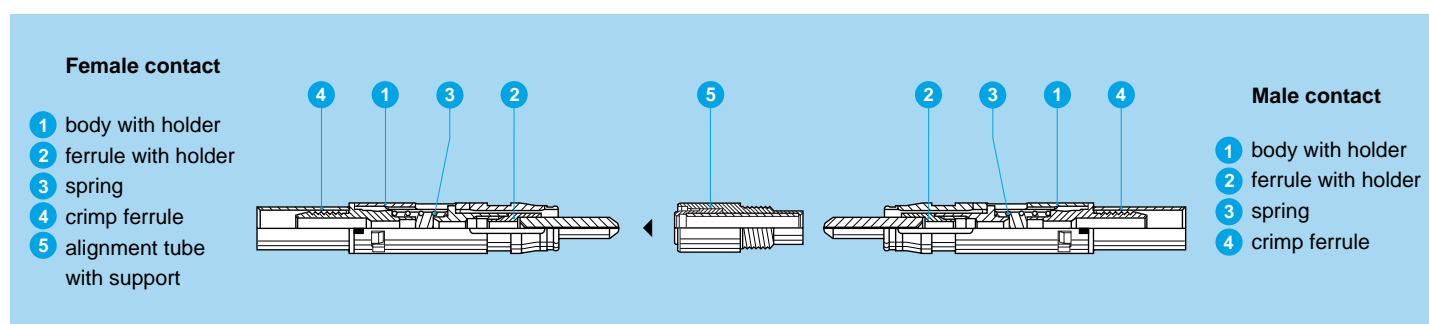

Technical Characteristics

Material and Treatment

Component	Material	Surface treatment (μm)	
		Cu	Ni
Body	PEEK	without treatment	
Ferrule	Ceramic	without treatment	
Holder	Alloy CuNiZn	without treatment	
Crimp holder	Brass	0.5	3
Spring	Stainless steel	without treatment	
Crimp ferrule	Cu 99	0.5	3
Support	Alloy CuNiZn	without treatment	
Alignment tube	Ceramic	without treatment	

Optical

Characteristic	Value	Standard	Method
Average insertion loss fibre 9/125 μm	0.10 dB	IEC 61300-03-04	Insertion Method B
Average insertion loss fibre 50/125 μm	0.25 dB	IEC 61300-03-04	Insertion Method B
Return loss fibre 9/125 μm (UPC)	≥ 45 dB	IEC 61300-03-06	Branching Device Met.
Return loss fibre 9/125 μm (Hand polish)	~ 30 dB	IEC 61300-03-06	Branching Device Met.

Note: Detailed characteristics are presented on pages 109 to 111.

Mechanical and Environmental

Characteristic	Value	Standard
Mating durability	10,000 cycles	IEC 61300-02-02
Damp heat steady state	up to 95 % at 60°C	IEC 61300-02-19
High temperature	+80°C	IEC 61300-02-18
Low temperature	-40°C	IEC 61300-02-17
Cable retention	100 N	IEC 61300-02-04
Impact (Method A)	1 m onto concrete floor	IEC 61300-02-12
Shock (3 cycles in 2 directions)	100 g, 10-50 ms; 20 g 6-9 ms	IEC 61300-02-09
Vibration (7 cycles)	Diagram 2 page 111	IEC 61300-02-01

Part Number Example

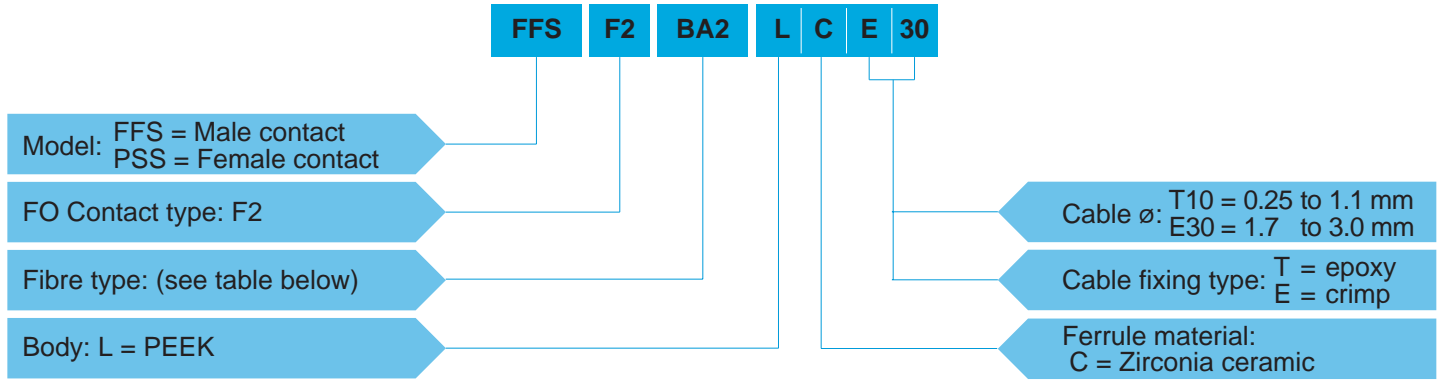

FFS.F2.BA2.LCE30 = Male F2 type fibre optic contact, ferrule bore diameter of 125 μm , PEEK body, Zirconia ceramic ferrule, crimp cable fixing, for tight jacket cable with a diameter between 1.7 to 3.0 mm.

Model - FO Contact Type

FFS.F2 Male F2 Fibre Optic Contact

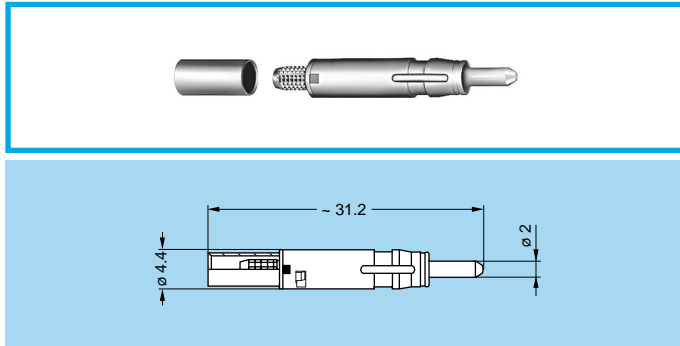

PSS.F2 Female F2 Fibre Optic Contact

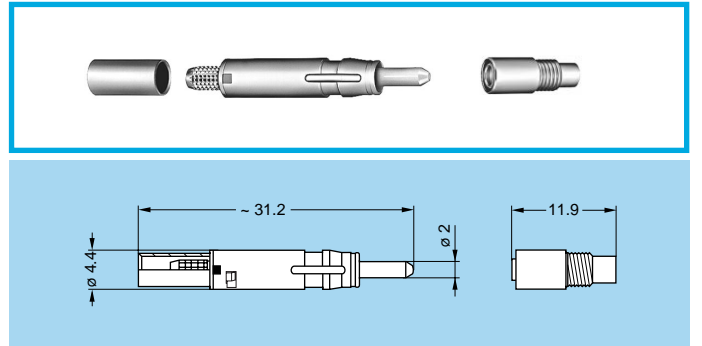

Fibre Type

The choice of the ferrule hole diameter is dependent upon the fibre cladding size. LEMO offers a range of ferrule hole diameters to suit the users' specific requirements.

Reference	\varnothing Core/Cladding (μm)	Ferrule hole diameter (μm)	Note 1)
BA2	9/125	125	●
BB2	50/125	126	●
BC2	62.5/125	127	○
BD2	100/125	128	○
FA2	100/140	140	○
FB2	100/140	144	●

● First choice alternative ○ Special order alternative

Note: ¹⁾ The BA2 type (ferrule hole 125 μm) is recommended for single-mode fibres. The BB2 type (ferrule hole 126 μm) is commonly used with multi-mode fibres.

Cable Fixing Type



Reference		Cable Structure	Cable ø
Cable fixing	Reference ø		
T	10	Buffer coated fibre	0.25 to 1.1
E	30	Tight jacket cable	1.7 to 3.0

Accessory

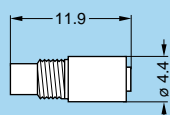

PSS Alignment device for F2 fibre optic contact

Part number

PSS.F2.290.NZZ

Note: Alignment device should be ordered as replacement item.

Insertion and Extraction of the Fibre Optic Contacts

Cable Termination

Detailed instructions for terminating single fibre cables with LEMO F2 fibre optic contacts are given in the reference manual DOC.FO.CF2.0000 supplied with the complete termination workstation (see page 103). After termination contacts shall be introduced in the main insulator as shown below. For purpose of cleaning they can also be removed.

Insertion and Extraction of the F1 Type Contact

Insertion

The fibre optic contact, male or female, terminated on the cable, must be inserted into the connector insulator from the back end until it comes to a stop (step 1 and 2). Check that the contact is correctly retained by gently pulling on it (step 3).

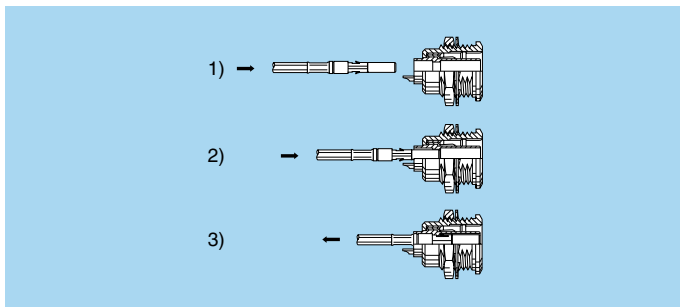

Extraction

Introduce the extractor, reference DCC.91.312.5LA (see page 105), in the insulator around the contact and push until it comes to a stop (step 1 and 2). Gently remove the fibre optic contact by pulling on the cable (step 3).

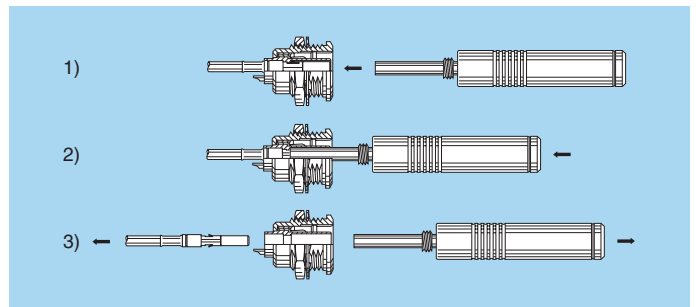

Insertion and Extraction of the F2 Type Contact

Insertion

The male fibre optic contact terminated on the cable must be inserted into the connector insulator from the back end until it comes to a stop. Make sure that the contact is correctly positioned into the inner antirotation key. Key is in line with the red dot on the rear of the contact (step 1). Check that the contact is correctly retained by gently pulling on it (step 2).

For female contacts, the alignment device shall be clipped onto the fibre optic contacts which is already fitted into female insulator. This procedure is performed using the alignment device, reference DCS.F2.035.PN. The alignment device shall be first installed onto threaded end of the alignment device (step 3). Then clip the adapter (step 4), unscrew and remove the alignment device (step 5).

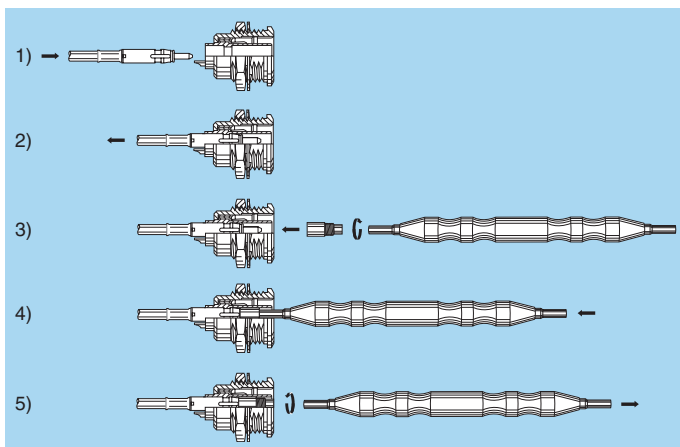

Extraction

Reverse the order of the operation previously described. For female contact remove first the alignment device. Screw the threaded end of the alignment device reference, DCS.F2.035.PN (step 1), onto the alignment device and pull out strongly (step 2). Then use the extractor reference, DCC.91.312.5LA, introduce it into the insulator and push until it comes to a stop to compress the contact body (step 3 and 4). Gently remove the fibre optic contact by pulling on the cable (step 5).

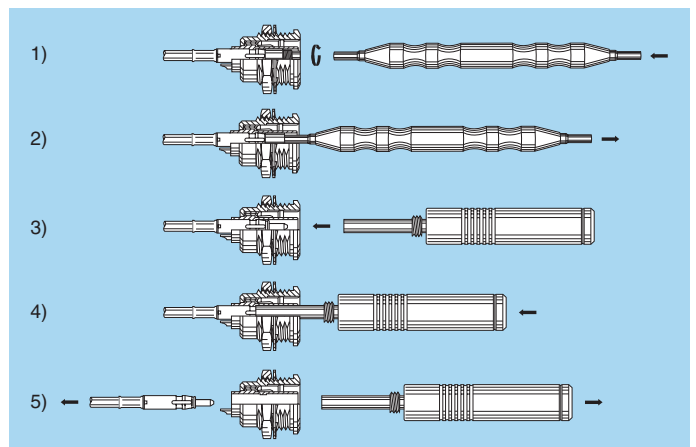

Note: The life time installation of the alignment device is minimum 300 cycles.

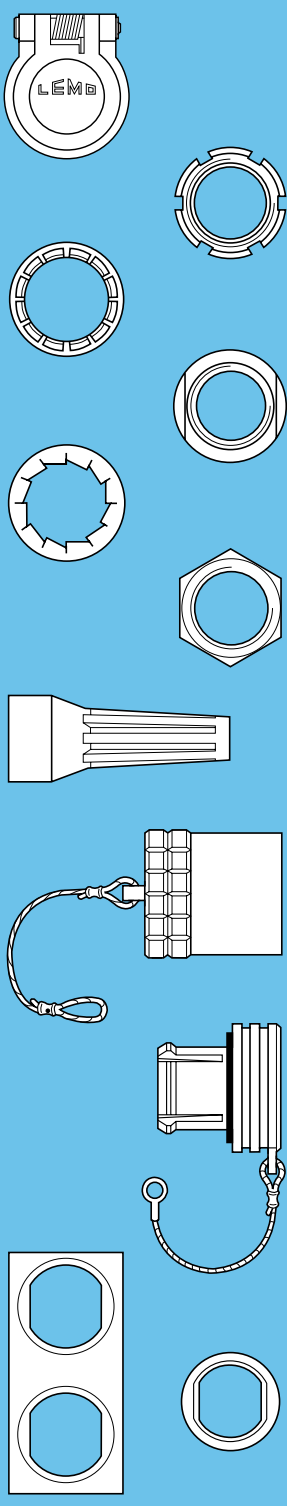

ACCESSORIES

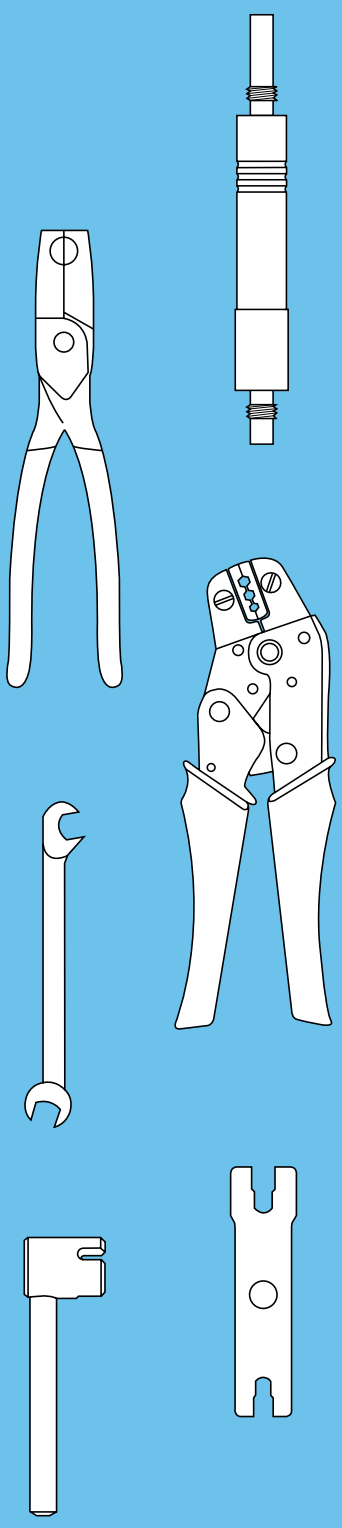

TOOLING

Accessories



male



female

FGG-EGG Insulators

Insulators for 2B-5B and 2K-5K series vary according to the fibre optic contact type chosen.

They are only necessary as replacement item when electrical crimp contacts are available.

	FO Contact		Insulator part number	
	Type F1		Male contact	Female contact
2B 2K	96A		FGG.2B.302.XLY	EGG.2B.402.XLY
	96C		FGG.2B.304.XLY	EGG.2B.404.XLY
	96E		FGG.2B.306.XLY	EGG.2B.406.XLY
	96J		FGG.2B.310.XL	EGG.2B.410.XL
3B 3K	07A		FGG.3B.302.CL	EGG.3B.402.CL
	96X		FGG.3B.322.XL	EGG.3B.422.XL
	97C		FGG.3B.344.XL	EGG.3B.444.XL
	97E		FGG.3B.346.XL	EGG.3B.446.XL
	97J		FGG.3B.350.XL	EGG.3B.450.XL
	97R		FGG.3B.356.XL	EGG.3B.456.XL
4B 4K	07C		FGG.4B.304.CL	EGG.4B.404.CL
	99H		FGG.4B.379.XL	EGG.4B.479.XL
	97F		FGG.4B.347.XL	EGG.4B.447.XL
	97L		FGG.4B.352.XL	EGG.4B.452.XL
	97R		FGG.4B.356.XL	EGG.4B.456.XL
	97T		FGG.4B.358.XL	EGG.4B.458.XL
	98E		FGG.4B.366.XL	EGG.4B.466.XL
	98L		FGG.4B.385.XL	EGG.4B.485.XL
5B 5K	07J		FGG.5B.340.CL	EGG.5B.440.CL

	FO Contact		Insulator part number	
	Type F2		Male contact	Female contact
2B 2K	92A		FGG.2B.302.EL	EGG.2B.402.EL
	92C		FGG.2B.304.EL	EGG.2B.404.EL
	92E		FGG.2B.306.EL	EGG.2B.406.EL
	92J		FGG.2B.310.EL	EGG.2B.410.EL
3B 3K	03A		FGG.3B.302.EL	EGG.3B.402.EL
	92X		FGG.3B.322.EL	EGG.3B.422.EL
	93B		FGG.3B.344.EL	EGG.3B.444.EL
	93E		FGG.3B.346.EL	EGG.3B.446.EL
	93J		FGG.3B.350.EL	EGG.3B.450.EL
	93R		FGG.3B.356.EL	EGG.3B.456.EL
	87E		FGG.3B.376.WL	EGG.3B.476.WL
	87R		FGG.3B.386.WL	EGG.3B.486.WL
4B 4K	03C		FGG.4B.304.EL	EGG.4B.404.EL
	95D		FGG.4B.375.EL	EGG.4B.475.EL
	93E		FGG.4B.346.EL	EGG.4B.446.EL
	93L		FGG.4B.352.EL	EGG.4B.452.EL
	93R		FGG.4B.356.EL	EGG.4B.456.EL
	93T		FGG.4B.358.EL	EGG.4B.458.EL
	94E		FGG.4B.366.EL	EGG.4B.466.EL
	94L		FGG.4B.385.EL	EGG.4B.485.EL
5B 5K	05C		FGG.4B.304.WL	EGG.4B.404.WL
	88E		FGG.4B.366.WL	EGG.4B.466.WL
	03J		FGG.5B.340.EL	EGG.5B.440.EL
	03N		FGG.5B.354.EL	EGG.5B.454.EL
	956		FGG.5B.356.WLL	EGG.5B.456.WLL
	94B		FGG.5B.383.EL	EGG.5B.483.EL



FGG-EGG Crimp electrical contacts

	FO Contact		ø A Contact LV	Contact part number	
	Types			Male	Female
	F1	F2			
2B 2K	96A	92A	0.9	FGG.2B.560.ZZC	EGG.2B.660.ZZM
	96C	92C	0.7	FGG.2B.555.ZZC	EGG.2B.655.ZZM
	96E	92E	0.7	FGG.2B.555.ZZC	EGG.2B.655.ZZM
	96J	92J	0.7	FGG.2B.555.ZZC	EGG.2B.655.ZZM
3B 3K	97C	93B	0.9	FGG.3B.560.ZZC	EGG.3B.660.ZZM
	97E	93E	0.9	FGG.3B.560.ZZC	EGG.3B.660.ZZM
	-	87E	0.9	FGG.3B.560.ZZC	EGG.3B.660.ZZM
	97J	93J	0.7	FGG.3B.555.ZZC	EGG.3B.655.ZZM
	97R	93R	0.7	FGG.3B.555.ZZC	EGG.3B.655.ZZM
	96X	92X	0.7	FGG.3B.555.ZZC	EGG.3B.655.ZZM
	-	87R	0.7	FGG.3B.555.ZZC	EGG.3B.655.ZZM

	FO Contact		ø A Contact LV +HV	Contact part number	
	Types			Male	Female
	F1	F2			
4B 4K	-	95D	1.3	FGG.4B.565.ZZC	EGG.4B.665.ZZM
	-	93E	1.3 ¹⁾	FGG.4K.565.ZZCY	EGG.3B.665.ZZM
	-		0.9	FGG.4B.560.ZZC	EGG.4B.660.ZZM
	97F	-	1.3	FGG.4B.565.ZZC	EGG.4B.665.ZZM
	97R	93R	0.9	FGG.4B.560.ZZC	EGG.4B.660.ZZM
	97L	93L	0.9	FGG.4B.560.ZZC	EGG.4B.660.ZZM
	98L	94L	0.7	FGG.4B.555.ZZC	EGG.4B.655.ZZM
	97T	93T	0.7	FGG.4B.555.ZZC	EGG.4B.655.ZZM
	-	88E	0.7	FGG.4B.555.ZZC	EGG.4B.655.ZZM
	99H	-	0.7	FGG.4B.555.ZZC	EGG.4B.655.ZZM
	98E	94E	0.7	FGG.4B.555.ZZC	EGG.4B.655.ZZM
	5B 5K	-	94B	2.0	FGG.5B.575.ZZC
-		956	2.0 ¹⁾	FGG.3B.575.ZZC	EGG.4B.675.ZZM
-			1.6 ¹⁾	FGG.4B.570.ZZC	EGG.2B.670.ZZM
-		90C	1.6 ¹⁾	FGG.4B.570.ZZC	EGG.2B.670.ZZM

Note: 1) Arrangements with special contact length.

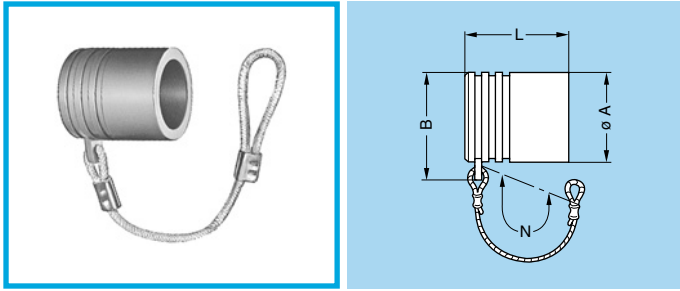

- Body material: Polyoxymethylene (POM) grey (or black)
- Cord material: Polyamide 6, grey (or black)
- Crimp ferrule material: Nickel-plated brass
- Gasket material: Silicone rubber
- Maximum operating temperature: 100°C
- Watertightness: IP61 according to IEC 60529

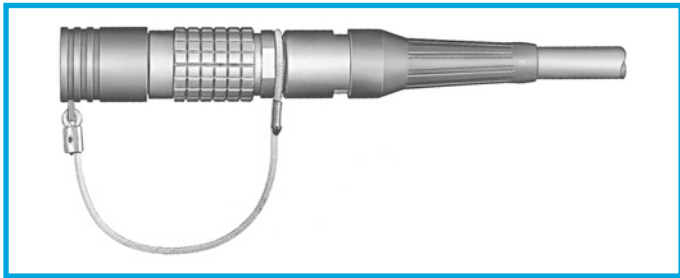

BFG Plug caps

Part number	Series	Dimensions (mm)			
		A	B	L	N
BFG.00.100.PCSG	00	7.5	9.8	10.0	60
BFG.0B.100.PCSG	0B	9.5	12.0	12.2	85
BFG.2B.100.PCSG	2B	15.0	18.0	15.0	85
BFG.3B.100.PCSG	3B	18.5	22.0	18.5	95

Note: This cap is available only with an alignment key (G). Upon request this cap can be supplied in black and the last letter «G» of the part number should be replaced with «N».

Fitting the cord

Slide the plug into the loop of the cord. Place the loop into the groove in front of the collet nut and tighten the loop.

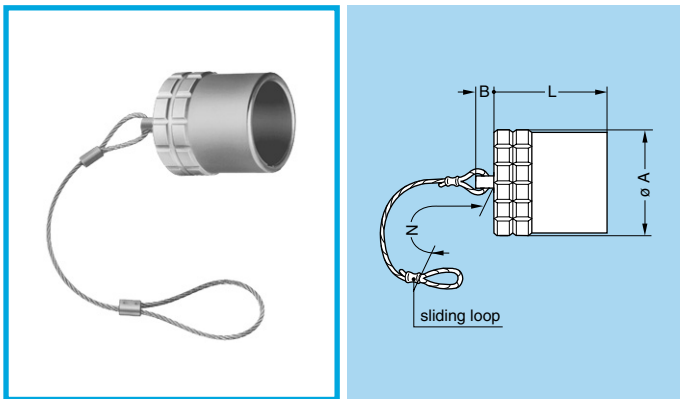

- Body material: Nickel-plated brass (Ni 3µm)
- Lanyard material: Stainless steel
- Crimp ferrule material: Nickel-plated brass + polyolefin
- O-ring material: Silicone rubber or FPM
- Maximum operating temperature: 135°C
- Watertightness: IP68 according to IEC 60529 for K series

BFG Plug caps with key (G)

Part number	Series	Dimensions (mm)			
		A	B	L	N
BFG.0K.100.NAS	0K	14.0	6	12.5	85
BFG.2K.100.NAS	2K	19.5	6	17.5	85
BFG.3K.100.NAS	3K	23.0	6	22.0	120
BFG.4B.100.NAS	4B	25.0	10	20.2	120
BFG.4K.100.NAS	4K	29.0	10	22.5	120
BFG.5B.100.NAS	5B	36.0	10	27.2	150
BFG.5K.100.NAS	5K	44.0	10	27.0	150

Note: This cap is available only with an alignment key (G). The last letter «S» of the part number stands for the material of the O-ring (silicone rubber). O-rings made from FPM are also available; if required, replace the letter «S» by «V».

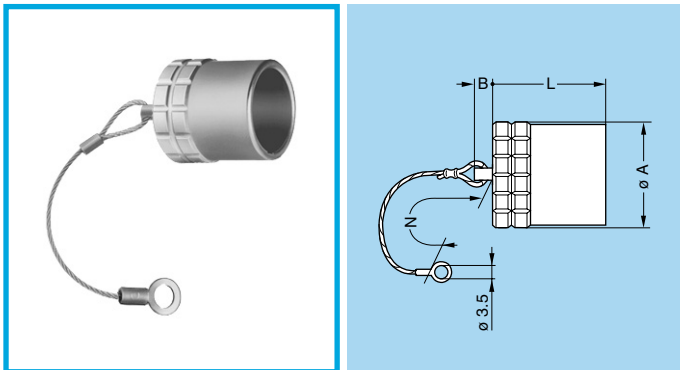

- Body material: Nickel-plated brass (Ni 3µm)
- Lanyard material: Stainless steel
- Crimp ferrule material: Nickel-plated brass + polyolefin
- O-ring material: Silicone rubber or FPM
- Maximum operating temperature: 135°C
- Watertightness: IP68 according to IEC 60529 for K series

BHG Plug caps, nut fixing or flange

Part number	Series	Dimensions (mm)			
		A	B	L	N
BHG.0K.100.NAS	0K	14.0	6	12.5	85
BHG.2K.100.NAS	2K	19.5	6	17.5	85
BHG.3K.100.NAS	3K	23.0	6	22.0	120
BHG.4B.100.NAS	4B	25.0	10	20.2	120
BHG.4K.100.NAS	4K	29.0	10	22.5	120
BHG.5B.100.NAS	5B	36.0	10	27.2	150
BHG.5K.100.NAS	5K	44.0	10	27.0	150

Note: This cap is available only with an alignment key (G). The last letter «S» of the part number stands for the material of the O-ring (silicone rubber). O-rings made from FPM are also available; if required, replace the letter «S» by «V».

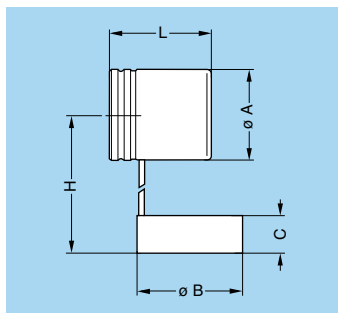

BFA Plug cap

Part number	Series	Dimensions (mm)				
		A	B	C	H	L
BFA.3K.170.800EN	3K	24	28	10	80	27

- Material: black EPDM

Note: These caps are suitable for use with any alignment key configuration.

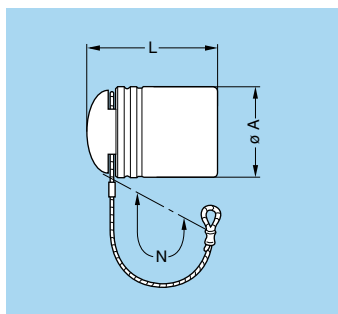

BFG Plug cap

Part number	Series	Dimensions (mm)		
		A	L	N
BFG.3K.100.EAN	3K	24	30	155

- Material: black EPDM
- Lanyard material: Stainless steel
- Crimp ferrule material: Nickel-plated brass + polyolefin

Note: These caps are suitable for use with any alignment key configuration.

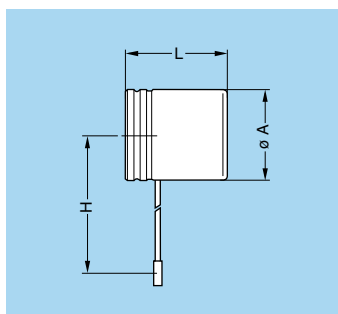

BHA Plug cap

Part number	Series	Dimensions (mm)		
		A	H	L
BHA.3K.100.715EN	3K	24	80	27

- Material: black EPDM

Note: These caps are suitable for use with any alignment key configuration.

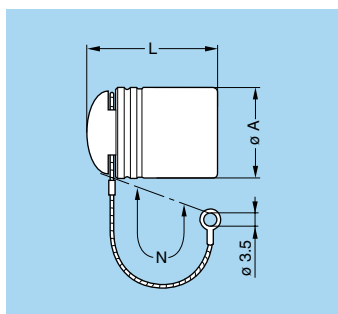

BHA Plug cap

Part number	Series	Dimensions (mm)		
		A	L	N
BHA.3K.100.EAN	3K	24	30	120

- Material: black EPDM
- Lanyard material: Stainless steel
- Crimp ferrule material: Nickel-plated brass + polyolefin

Note: These caps are suitable for use with any alignment key configuration.

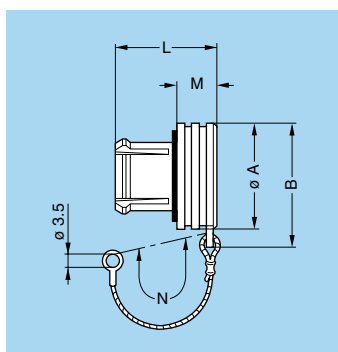

BRA Blanking caps for fixed sockets and free straight sockets

Part number	Series	Dimensions (mm)				
		A	B	L	M	N
BRA.00.200.PCSG	00	7.5	9.8	9.0	3.5	60
BRA.0B.200.PCSG	0B	10.0	12.5	11.0	4.8	60
BRA.2B.200.PCSG	2B	18.0	21.0	14.5	6.0	60
BRA.3B.200.PCSG	3B	22.0	25.5	17.0	7.0	60

Note: These caps are suitable for use with any alignment key configuration. On request this cap can be supplied in black. If so, replace the last letter «G» of the part number by «N».

- Body material: Polyoxymethylene (POM) grey (or black)
- Cord material: Polyamide 6, grey (or black)
- Crimp ferrule material: Nickel-plated brass
- Gasket material: Silicone rubber
- Maximum operating temperature: 100°C
- Watertightness: IP61 according to IEC 60529

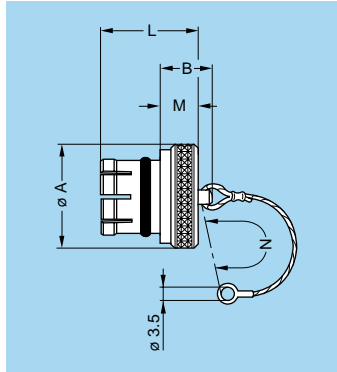

- Body material: Nickel-plated brass (Ni 3 μ m)
- Lanyard material: Stainless steel
- Crimp ferrule material: Nickel-plated brass + polyolefin
- O-ring material: Silicone rubber or FPM
- Maximum operating temperature: 135°C

BRE Blanking caps for fixed and free sockets

Part number	Series	Dimensions (mm)				
		A	B	L	M	N
BRE.00.200.NAS	00	8	9.5	8.8	3.5	60
BRE.0S.200.NAS	0B	10	10.5	10.5	4.5	85
BRE.2S.200.NAS	2B	18	12.0	14.0	6.0	85
BRE.3S.200.NAS	3B	22	14.0	18.0	8.0	120
BRE.4S.200.NAS	4B	28	20.0	23.0	10.0	120
BRE.5S.200.NAS	5B	40	22.0	30.0	12.0	150

Note: These caps are suitable for use with any alignment key configuration. The last letter «S» of the part number stands for the O-ring material (silicone rubber). O-rings made from FPM are also available; if required, replace the letter «S» by «V».

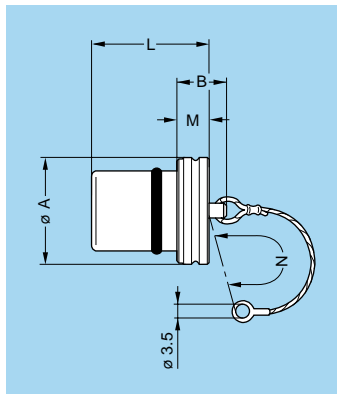

- Body material: Nickel-plated brass (Ni 3 μ m)
- Lanyard material: Stainless steel
- Crimp ferrule material: Nickel-plated brass + polyolefines
- O-ring material: Silicone rubber or FPM
- Maximum operating temperature: 135°C
- Watertightness: IP68 according to IEC 60529

BRE Blanking caps for fixed and free sockets

Part number	Series	Dimensions (mm)				
		A	B	L	M	N
BRE.0K.200.NAS	0K	15.0	10	15.0	4	85
BRE.2K.200.NAS	2K	20.5	14	24.0	8	85
BRE.3K.200.NAS	3K	24.0	14	28.0	8	120
BRE.4K.200.NAS	4K	30.0	20	30.5	10	120
BRE.5K.200.NAS	5K	44.0	22	37.0	12	150

Note: These caps are suitable for use with any alignment key configuration. The last letter «S» of the part number stands for the O-ring material (silicone rubber). O-rings made from FPM are also available; if required, replace the letter «S» by «V».

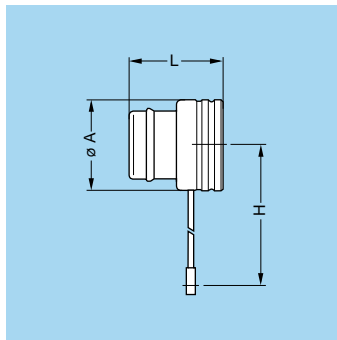

BRA Blanking cap for free sockets

Part number	Series	Dimensions (mm)		
		A	H	L
BRA.3K.100.715EN	3K	24	80	25

- Material: black EPDM

Note: These caps are suitable for use with any alignment key configuration.

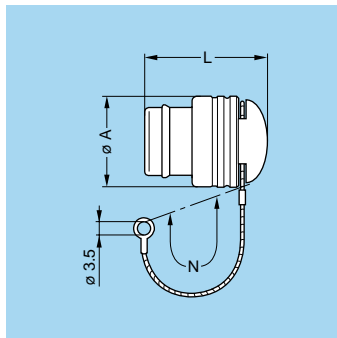

BRA Blanking cap for free sockets

Part number	Series	Dimensions (mm)		
		A	L	N
BRA.3K.200.EAN	3K	24	26	120

- Material: black EPDM
- Lanyard material: Stainless steel
- Crimp ferrule material: Nickel-plated brass + polyolefin

Note: These caps are suitable for use with any alignment key configuration.

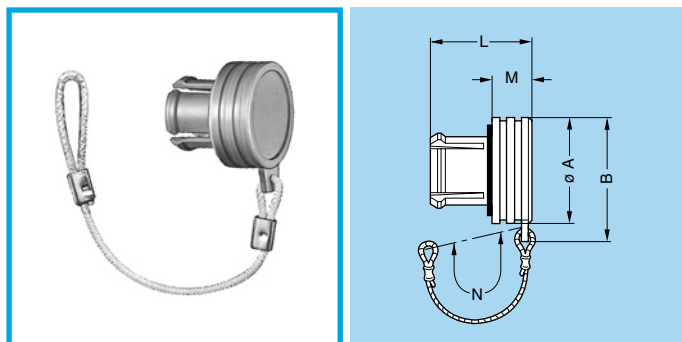

- Body material: Polyoxymethylene (POM) grey (or black)
- Cord material: Polyamide 6, grey (or black)
- Crimp ferrule material: Nickel-plated brass
- Gasket material: Silicone rubber
- Maximum operating temperature: 100°C
- Watertightness: IP61 according to IEC 60529

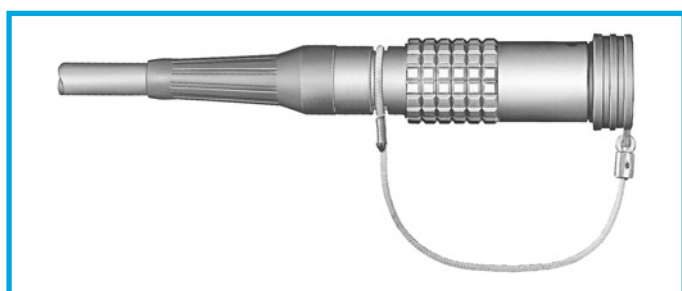

BRD Blanking caps for free sockets

Part number	Series	Dimensions (mm)				
		A	B	L	M	N
BRD.00.200.PCSG	00	7.5	9.8	9.0	3.5	85
BRD.0B.200.PCSG	0B	10.0	12.5	11.0	4.8	85
BRD.2B.200.PCSG	2B	18.0	21.0	14.5	6.0	85
BRD.3B.200.PCSG	3B	22.0	25.5	17.0	7.0	95

Note: On request this cap is available in black. If required, replace the last letter «G» of the part number by «N».

Fitting the cord

Slide the socket into the loop of the cord.
Place the loop into the groove in front of the collet nut.
Tighten the loop.

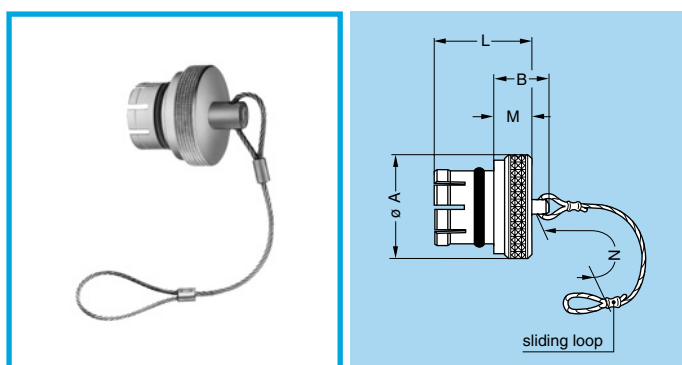

- Body material: Nickel-plated brass (Ni 3 µm)
- Lanyard material: Stainless steel
- Crimp ferrule material: Nickel-plated brass + polyolefin
- O-ring material: Silicone rubber or FPM
- Maximum operating temperature: 135°C

BRF Blanking caps for free sockets

Part number	Series	Dimensions (mm)				
		A	B	L	M	N
BRF.00.200.NAS	00	8	7.5	8.8	3.5	85
BRF.0S.200.NAS	0B	10	9.5	10.5	4.5	85
BRF.2S.200.NAS	2B	18	12.0	14.0	6.0	85
BRF.3S.200.NAS	3B	22	14.0	18.0	8.0	120
BRF.4S.200.NAS	4B	28	20.0	23.0	10.0	120
BRF.5S.200.NAS	5B	40	22.0	30.0	12.0	150

Note: These caps are suitable for use with any alignment key configuration. The last letter «S» of the part number stands for the O-ring material (silicone rubber). O-rings made from FPM are also available; if required, replace the letter «S» by «V».

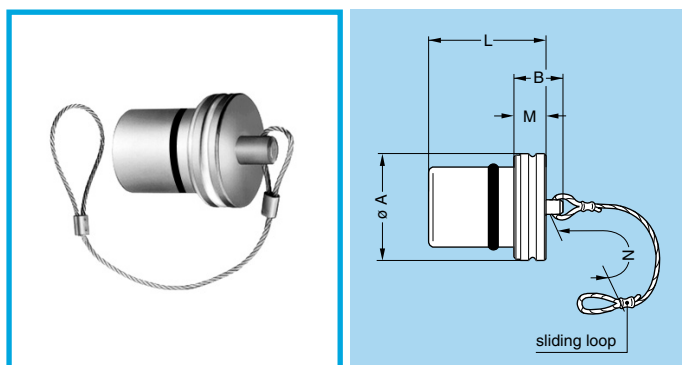

- Body material: Nickel-plated brass (Ni 3 µm)
- Lanyard material: Stainless steel
- Crimp ferrule material: Nickel-plated brass + polyolefin
- O-ring material: Silicone rubber or FPM

BRF Blanking caps for free sockets

Part number	Series	Dimensions (mm)				
		A	B	L	M	N
BRF.0K.200.NAS	0K	15.0	10	15.0	4	85
BRF.2K.200.NAS	2K	20.5	14	24.0	8	85
BRF.3K.200.NAS	3K	24.0	14	28.0	8	120
BRF.4K.200.NAS	4K	30.0	20	30.5	10	120
BRF.5K.200.NAS	5K	44.0	22	37.0	12	150

Note: These caps are suitable for use with any alignment key configuration. The last letter «S» of the part number stands for the O-ring material (silicone rubber). O-rings made from FPM are also available; if required, replace the letter «S» by «V».

- Maximum operating temperature: 135°C
- Watertightness: IP68 according to IEC 60529

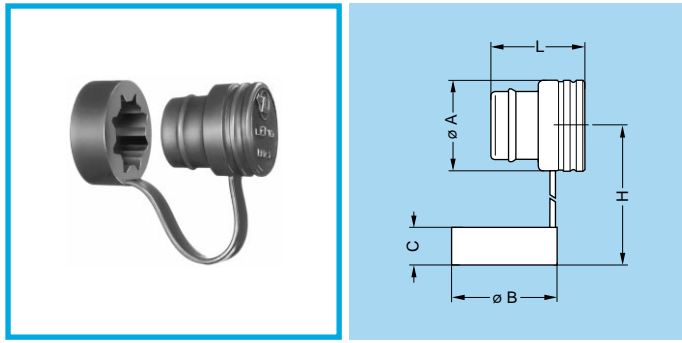

BRD Blanking caps for free sockets

Part number	Series	Dimensions (mm)				
		A	B	C	H	L
BRD.3K.170.800EN	3K	24	28	10	80	25

- Material: black EPDM

Note: These caps are suitable for use with any alignment key configuration.

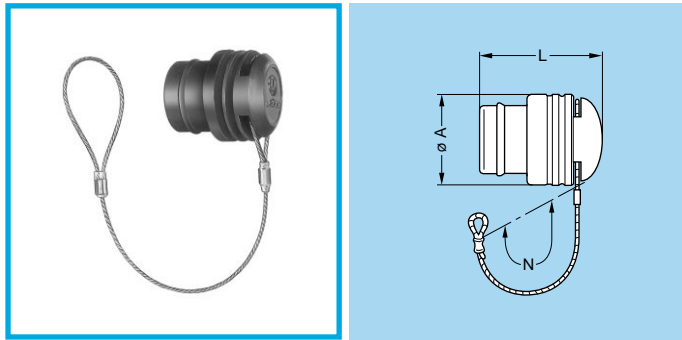

BRF Blanking caps for free sockets

Part number	Series	Dimensions (mm)		
		A	L	N
BRF.3K.200.EAN	3K	24	26	155

- Material: black EPDM
- Lanyard material: Stainless steel
- Crimp ferrule material: Nickel-plated brass + polyolefin

Note: These caps are suitable for use with any alignment key configuration.

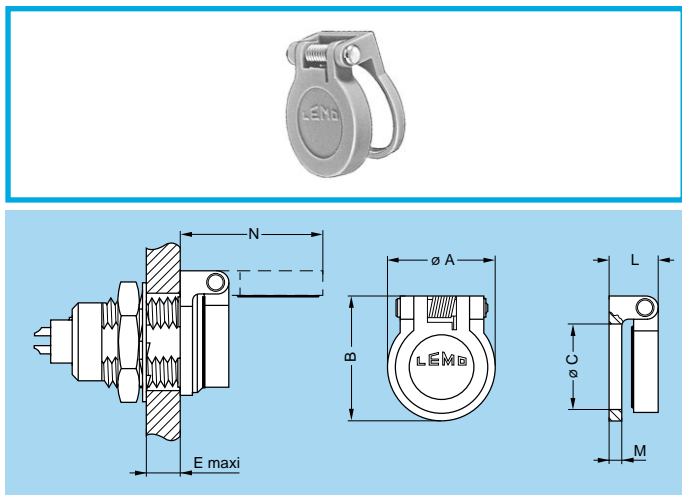

BRR Spring loaded dust caps for ERA, ERN and EG sockets or PSA and PK fixed sockets

Part number	Series	Dimensions (mm)						
		A	B	C	E	L	M	N
BRR.0S.200.PZSG	0B	11.0	13.3	9.0	5.8	5.0	1.2	15.3
BRR.2S.200.PZSG	2B	18.6	22.4	15.2	6.5	8.2	2.0	26.2
BRR.3S.200.PZSG	3B	22.5	26.5	18.2	9.0	8.8	2.5	30.8

Note: On request, this cap is available in black. If so replace the last letter «G» of the part number by «N».

- Body material: Polyoxymethylene (POM) grey (or black)
- Gasket material: Silicone rubber
- Spring material: Stainless steel
- Axes material: Nickel-plated brass
- Maximum operating temperature: 100°C
- Watertightness: IP61 according to IEC 60529

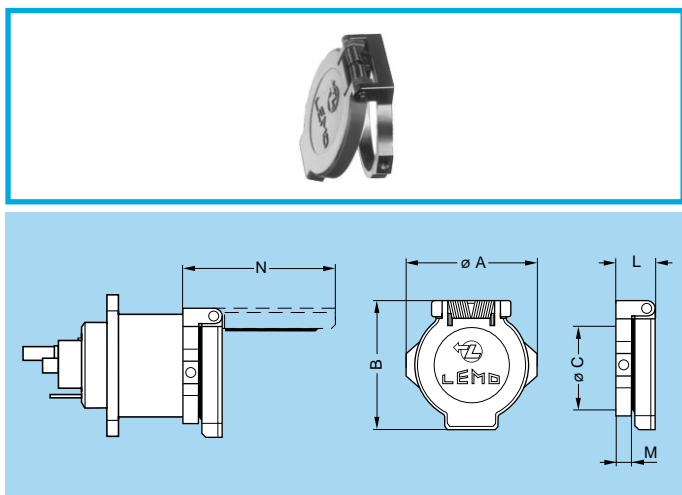

BRR Spring loaded dust cap for ED and EB fixed sockets

Part number	Series	Dimensions (mm)					
		A	B	C	L	M	N
BRR.3K.200.PZSG	3K	29	29	23	8.1	3	33.2

Note: On request, this cap is available in black. If so replace the last letter «G» of the part number by «N».

- Cap material: Polyoxymethylene (POM) grey (or black)
- Body material: Nickel-plated brass
- Gasket material: Silicone rubber
- Spring material: Stainless steel
- Axes material: Nickel-plated brass
- Maximum operating temperature: 100°C
- Watertightness: IP61 according to IEC 60529

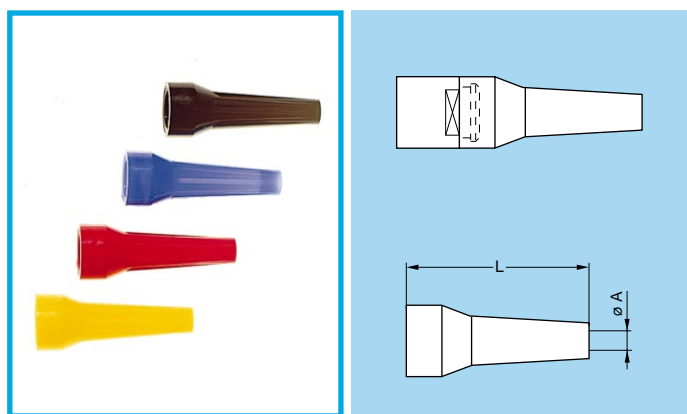

GM• Bend reliefs (Polyurethane)

A bend relief made from thermoplastic polyurethane elastomer (Desmopan 786) can be fitted over LEMO plugs and sockets that are supplied with a specially fitted nut. These are available in nine different colours that match with the GRA insulating washers (see page 93).

Use the part numbers shown below to order this accessory separately.

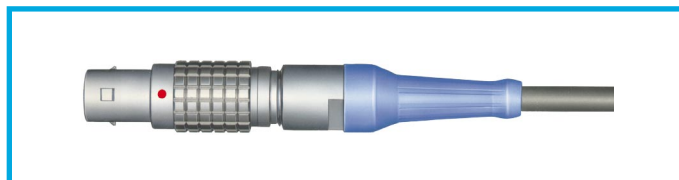

Main characteristics

- Material: Polyurethane elastomer
- Temperature range in dry atmosphere: -40°C to +80°C

Part number	Dimensions (mm)				Series	Part number of nut for fitting the bend relief
	Bend relief		Cable ø			
	A	L	max.	min.		
GMA.00.012.DG	1.2	22	1.4	1.1	00	FFM.00.131.LC
GMA.00.018.DG	1.8	22	2.1	1.8		
GMD.00.025.DG	2.5	22	2.8	2.5		
GMD.00.028.DG	2.8	22	3.1	2.8		
GMD.00.032.DG	3.2	22	3.5	3.2		
GMA.0B.025.DG	2.5	24	2.9	2.5	0B	FFM.0B.130.LC
GMA.0B.030.DG	3.0	24	3.4	3.0	2B	FFM.2B.132.LC ¹⁾
GMA.0B.035.DG	3.5	24	3.9	3.5		
GMA.0B.040.DG	4.0	24	4.4	4.0	0K	FFM.0E.130.LC
GMA.0B.045.DG	4.5	24	5.2	4.5		
GMA.1B.040.DG	4.0	30	4.4	4.0	3B	FFM.3B.131.LC ²⁾
GMA.1B.045.DG	4.5	30	4.9	4.5		
GMA.1B.054.DG	5.4	30	6.0	5.4		
GMA.2B.040.DG	4.0	36	4.5	4.0	2B	FFM.2B.130.LC
GMA.2B.045.DG	4.5	36	5.0	4.5	4B	FFM.4B.132.LC ³⁾
GMA.2B.050.DG	5.0	36	5.5	5.0	2K	FFM.2E.130.LC
GMA.2B.060.DG	6.0	36	6.5	6.0	3K	FFM.3K.133.LC
GMA.2B.070.DG	7.0	36	7.7	7.0	4K	FFM.4K.132.LC
GMA.2B.080.DG	7.8	36	8.8	7.8	5K	FFM.5K.132.LC
GMA.3B.050.DG	4.5	42	5.2	4.5	3B	FFM.3B.130.LC
GMA.3B.060.DG	6.0	42	6.9	6.0		
GMA.3B.070.DG	7.0	42	7.9	7.0	3K	FFM.3E.130.LC
GMA.3B.080.DG	8.0	42	8.9	8.0	4K	FFM.4K.133.LC
GMA.3B.090.DG	9.0	42	10.0	9.0	5K	FFM.5K.131.LC
GMA.4B.080.DG	8.0	60	9.0	8.0	4B	FFM.4B.130.LC
GMA.4B.010.DG	10.0	60	10.9	10.0		
GMA.4B.011.DG	11.0	60	11.9	11.0	4K	FFM.3K.132.LC
GMA.4B.012.DG	12.0	60	13.0	12.0	5K	FFM.5K.133.LC
GMA.4B.013.DG	13.5	60	14.5	13.5		

Note: The last letter «G» of the part number indicates the grey colour of the bend relief. For ordering a bend relief with another colour, see table on page 92 and replace the letter «G» by the letter of the required colour.

See also detailed information for each series: B series on page 61; K series on page 61.

¹⁾ For use only with connectors from series 2B equipped with cable fixing type M and where a bend relief from series 0B is used.

²⁾ For use only with connectors from series 3B equipped with cable fixing type M and where a bend relief from series 1B is used.

³⁾ For use only with connectors from series 4B equipped with cable fixing type M and where a bend relief from series 2B is used.

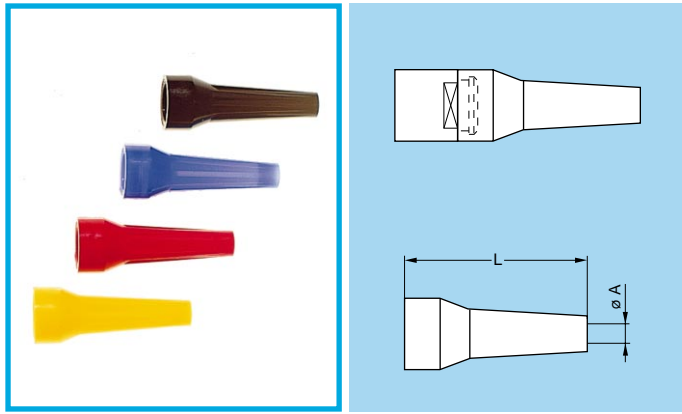

GM Bend reliefs (Silicone)

A bend relief has been designed for connectors used in applications at high temperature or requiring vapor sterilization.

These bend reliefs are different from previous ones; their material, a silicone elastomer, is noted for its retention of flexibility over a wide temperature range. They are available in nine colours.

Use the part numbers shown below to order this accessory separately.

Main characteristics

- Material: Silicone elastomer VMQ
- Temperature range in dry atmosphere: -60°C to +200°C
- Temperature range in water steam: +140°C
- Inflammability: not flammable (no UL classification)

Part number	Dimensions (mm)				Series	Part number of nut for fitting the bend relief
	Bend relief		Cable \varnothing			
	A	L	max.	min.		
GMA.0B.025.RG	2.5	27	2.9	2.5	0B	FFM.0B.130.LC
GMA.0B.030.RG	3.0	27	3.4	3.0		
GMA.0B.035.RG	3.5	27	3.9	3.5	2B	FFM.2B.132.LC ¹⁾
GMA.0B.040.RG	4.0	27	4.4	4.0		
GMA.0B.045.RG	4.5	27	5.2	4.5	0K	FFM.0E.130.LC
GMA.1B.040.RG	4.0	34	4.4	4.0	3B	FFM.3B.131.LC ²⁾
GMA.1B.045.RG	4.5	34	5.0	4.5		
GMA.2B.040.RG	4.0	41	4.4	4.0	2B	FFM.2B.130.LC
GMA.2B.045.RG	4.5	41	5.0	4.5	4B	FFM.4B.132.LC ³⁾
GMA.2B.051.RG	5.1	41	5.6	5.1		
GMA.2B.057.RG	5.7	41	6.2	5.7	2K	FFM.2E.130.LC
GMA.2B.063.RG	6.3	41	7.0	6.3	3K	FFM.3K.133.LC
GMA.2B.071.RG	7.1	41	7.9	7.1	4K	FFM.4K.132.LC
GMA.2B.080.RG	8.0	41	9.0	8.0	5K	FFM.5K.132.LC

Note: The last letter «G» of the part number indicates the grey colour of the bend relief. For ordering a bend relief with another colour, see table on page 92 and replace the letter «G» by the letter of the required colour.

See also detailed information for each series: B series on page 61; K series on page 61.

¹⁾ For use only with connectors from series 2B equipped with cable fixing type M and where a bend relief from series 0B is used.

²⁾ For use only with connectors from series 3B equipped with cable fixing type M and where a bend relief from series 1B is used.

³⁾ For use only with connectors from series 4B equipped with cable fixing type M and where a bend relief from series 2B is used.

Note: The selection of pigments, which should remain stable at high temperature, is limited by new regulations. For this reason, some colours will be a shade different from those used for Desmopan bend reliefs. The selected solutions represent the best possible compromise.

Ref.	Colour	Ref.	Colour
A	blue	N	black
B	white	R	red
G	grey	S	orange
J	yellow	V	green
M	brown		

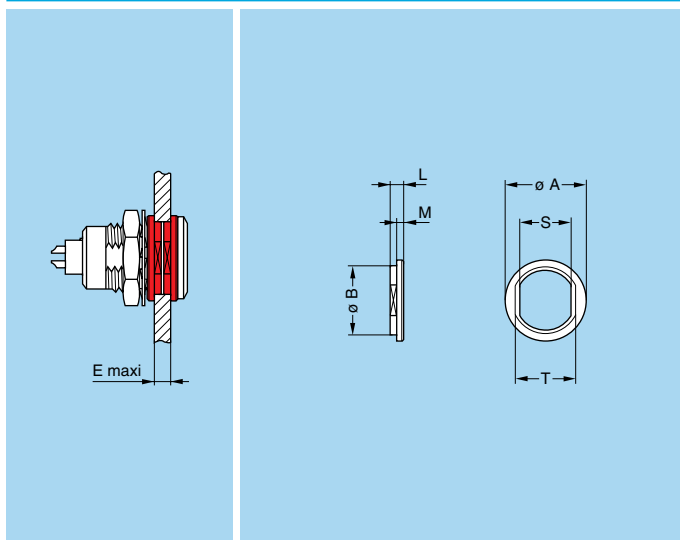

- Material: Polyamide
- Maximum operating temperature: 90°C

GRA Insulating washers

Sockets or plugs mounted on panels can be fitted with insulating washers. The nine colours available combined with those for the overall protective coverings with bend relief makes colour coding possible.

Part number	Series	Dimensions (mm)						
		A	B	E	L	M	S	T
GRA.00.269.GG	00	10.0	8.8	4.5	1.8	1.0	6.4	8.0
GRA.0S.269.GG	0B	12.0	10.8	6.0	1.8	1.0	8.3	9.9
GRA.2S.269.GG	2B	21.1	17.9	7.3	2.3	1.3	13.6	16.2
GRA.3S.269.GG	3B	25.0	21.8	10.3	2.2	1.2	16.7	20.2
GRA.4S.269.GG	4B	31.9	28.7	10.5	2.5	1.5	23.6	27.1

Note: Insulating washers for series 5B are available on request.

Caution: These insulating washers can be used with fixed and straight sockets with across flat dimension S1 equivalent to the S dimension of the washer.

Ref.	Colour	Ref.	Colour
A	blue	N	black
B	white	R	red
G	grey	S	orange
J	yellow	V	green
M	brown		

Note: The last letter «G» of the part number indicates the colour grey for the insulating washer. To obtain an insulating washer of another colour, refer to the table above and change the letter «G» of the part number to the corresponding letter of the colour required.

For the panel cut-out, please consult chapter «Panel cut-out» on pages 18, 26 and 45.

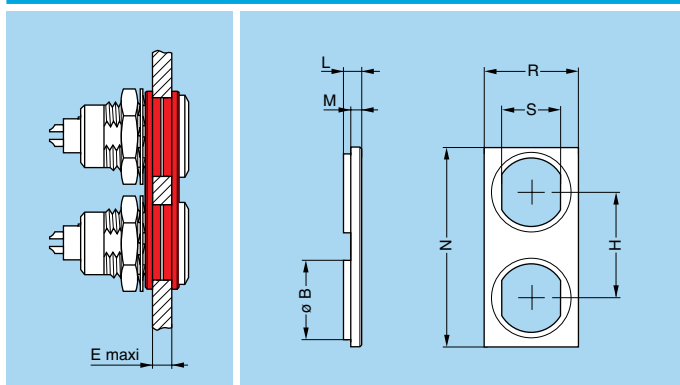

- Material: Polyamide
- Maximum operating temperature: 90°C

GRC Double panel washers

Double panel washers have been designed to make the drilling of panel holes easier for mounting fixed and straight sockets. The combination of the nine different colours of the double panel washers and of the overall protective coverings with bend relief makes colour coding possible.

Part number	Series	Dimensions (mm)							
		B	E	H	L	M	N	R	S
GRC.0S.260.HG	0B	10.9	5	14	2.5	1.5	26.5	12.5	8.3

Caution: These double panel washers can be used with fixed or free sockets with across flat dimension S1 equivalent to the S dimension of the washer.

Ref.	Colour	Ref.	Colour
A	blue	N	black
B	white	R	red
G	grey	S	orange
J	yellow	V	green
M	brown		

Note: The last letter «G» of the washer's part number indicates the colour grey. For other colours, refer to the above table and replace letter «G» by the one corresponding to the colour required.

For the panel cut-out, please consult chapter «Panel cut-out» on page 26.

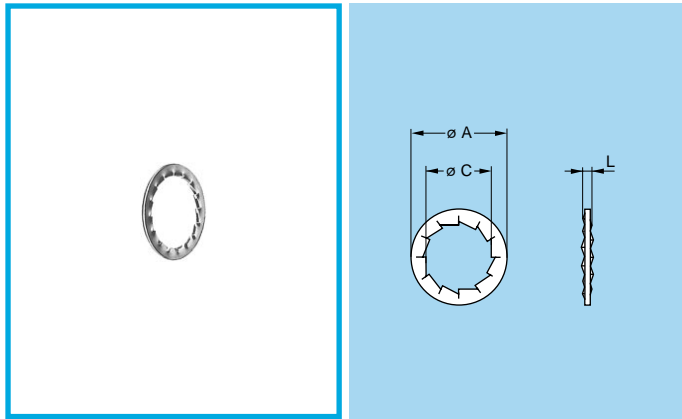

- Material: Nickel-plated bronze (3 μm)

GBA Locking washers

Part number	Series	Dimensions (mm)		
		A	C	L
GBA.00.250.FN	00	9.5	7.1	1.0
GBA.0S.250.FN	0B	12.5	9.1	1.0
GBA.2S.250.FN	2B	19.5	15.1	1.2
GBA.3S.250.FN	3B	25.0	18.1	1.4
GBA.4S.250.FN	4B	32.0	25.1	1.4

Note: To order this accessory separately, use the above part numbers.

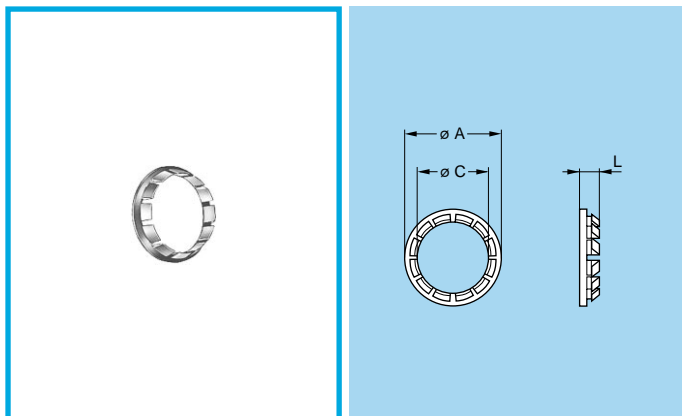

- Material: Nickel-plated brass (3 μm)

GBB Tapered washers

Part number	Series	Dimensions (mm)		
		A	C	L
GBB.00.250.LN	00	9	7.1	2.0
GBB.0S.250.LN	0B	11	9.1	2.5
GBB.2S.250.LN	2B	18	15.1	4.0
GBB.3S.250.LN	3B	22	18.1	4.5
GBB.4S.250.LN	4B	28	25.2	5.0
GBB.5S.250.LN	5B	40	35.2	7.5

Note: Sockets of series 5B are always supplied with a tapered washer. To order this accessory separately, use the above part numbers.

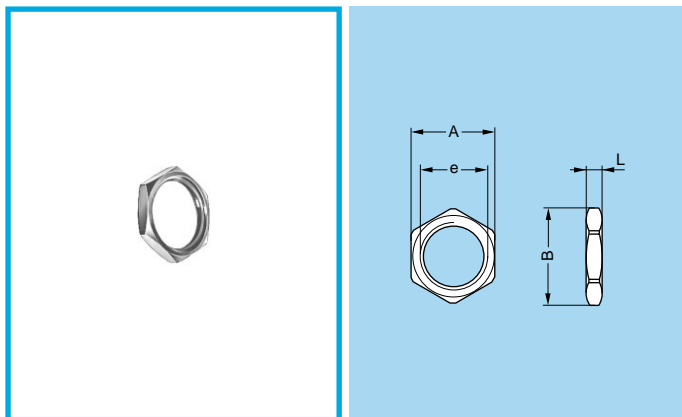

- Material:
 - Nickel-plated brass (3 μm)
 - Natural anodized aluminium alloy
 - Stainless steel

GEA Hexagonal nuts

Part number	Series	Dimensions (mm)			
		A	B	e	L
GEA.00.240.LN	00	9	10.2	M7 x 0.50	2.0
GEA.0S.240.LN	0B	11	12.4	M9 x 0.60	2.0
GEA.0E.240.LN	0K	17	19.2	M14 x 1.00	2.5
GEA.2S.240.LN	2B	17	19.2	M15 x 1.00	2.7
GEA.2E.240.LN	2K	24	27.0	M20 x 1.00	4.0
GEA.3S.240.LN	3B	22	25.0	M18 x 1.00	3.0
GEA.3E.240.LN	3K	30	34.0	M24 x 1.00	5.0
GEA.4S.240.LN	4B	30	34.0	M25 x 1.00	5.0
GEA.4E.240.LN	4K	36	40.5	M30 x 1.00	7.0

Note: To order this part separately, use the above part numbers. The last letters «LN» of the part number refer to the nut material and treatment. If a nut in aluminium alloy or stainless steel is desired, replace the last letters of the part number by «PT» or «AZ» respectively.

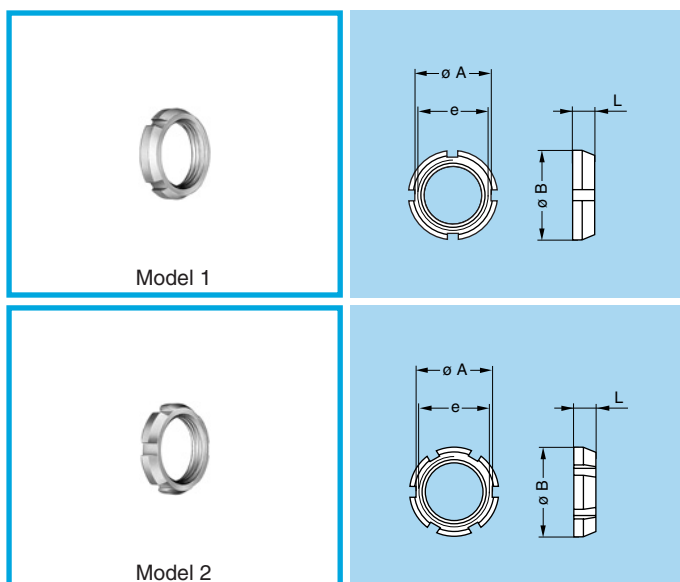

GEG Notched nuts

Part number	Series	Model	Dimensions (mm)			
			A	B	e	L
GEG.00.240.LC	00	1	8.7	10	M7 x 0.5	2.5
GEG.0S.240.LC	0B	1	10.5	12	M9 x 0.6	2.5
GEG.0E.240.LC	0K	1	15.8	18	M14 x 1.0	3.5
GEG.2S.240.LC	2B	2	17.5	20	M15 x 1.0	3.5
GEG.2E.240.LC	2K	2	22.5	25	M20 x 1.0	3.5

- Material: Chrome-plated brass (Ni 3 μm + Cr 0.3 μm)

Note: 00, 0B and 2B series fixed and free sockets for back panel mounting are always delivered with this notched nut. To order this accessory separately, use the above part numbers.

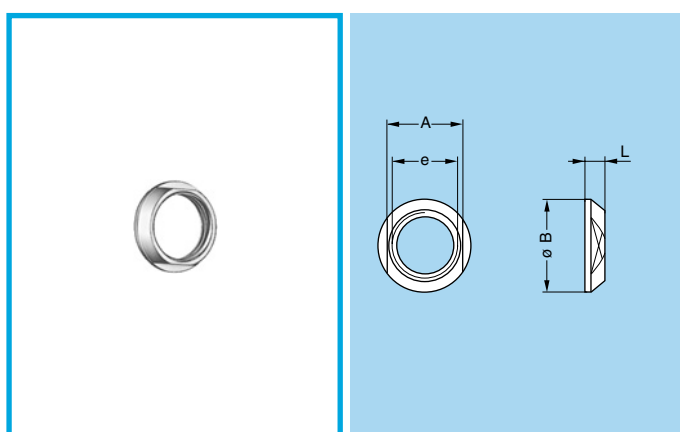

GEC Conical nuts

Part number	Series	Dimensions (mm)				
		A	B	e	L	S1
GEC.00.240.LC	00	8	10.0	M7 x 0.5	2.5	8
GEC.0S.240.LC	0B	10	12.0	M9 x 0.6	2.5	10
GEC.0E.240.LC	0K	16	18.0	M14 x 1.0	3.0	16
GEC.2S.240.LC	2B	17	20.0	M15 x 1.0	3.8	17
GEC.2E.240.LC	2K	22	25.0	M20 x 1.0	5.0	22
GEC.3S.240.LC	3B	20	24.0	M18 x 1.0	4.5	20
GEC.3E.240.LC	3K	27	30.0	M24 x 1.0	4.5	27
GEC.4S.240.LC	4B	27	30.0	M25 x 1.0	4.5	27
GEC.4K.241.LC	4K	32	35.5	M30 x 1.0	5.0	32
GEC.5S.240.LC	5B	37	41.0	M35 x 1.0	5.0	37

- Material: Chrome-plated brass (Ni 3 μm + Cr 0.3 μm)

Note: 3B, 3K, 4B, 4K, 5B and 5K series fixed and free sockets for back panel mounting are always delivered with a conical nut. To order this accessory separately, use the part numbers in the table above.

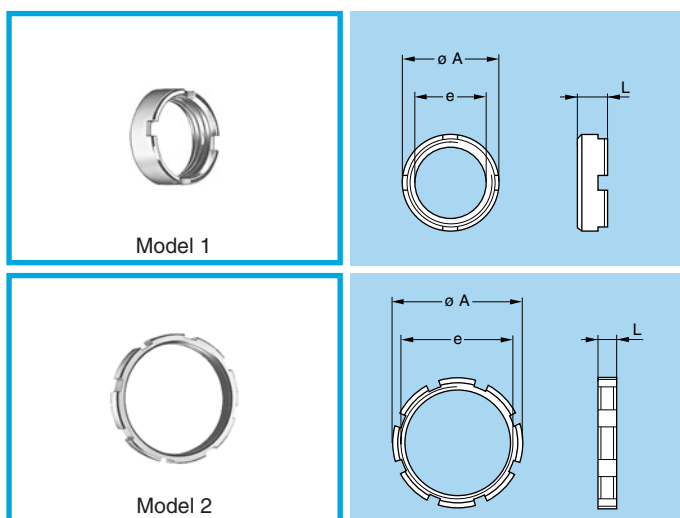

GEB Round nuts

Part number	Series	Model	Dimensions (mm)		
			A	e	L
GEB.00.240.LN	00	1	9.0	M7 x 0.50	4.0
GEB.0S.240.LN	0B	1	11.0	M9 x 0.60	4.0
GEB.2S.240.LN	2B	1	18.0	M15 x 1.00	5.5
GEB.3S.240.LN	3B	1	22.0	M18 x 1.00	5.5
GEB.4S.240.LN	4B	1	28.0	M25 x 1.00	6.0
GEB.5S.240.LN	5B	2	40.0	M35 x 1.00	8.0
GEB.5E.240.LN	5K	2	54.0	M45 x 1.50	8.0

- Material: Nickel-plated brass (3 μm)

Note: 5B and 5K series sockets are always supplied with model 2 round nuts. To order this accessory separately, use the part numbers in the table above.

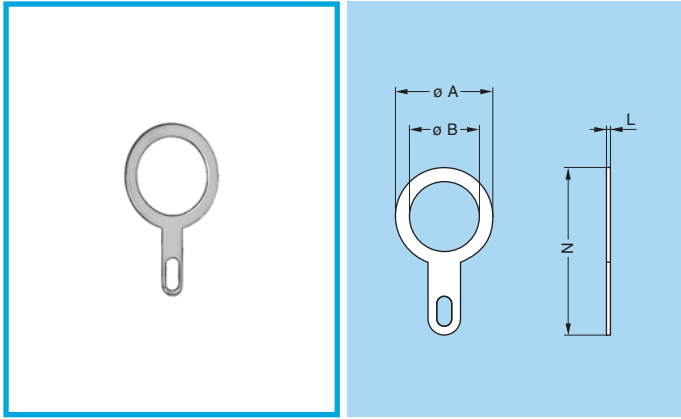

GCA Earthing washers

Part number	Series	Dimensions (mm)			
		A	B	L	N
GCA.00.255.LT	00	9.5	7.1	0.4	18.2
GCA.0S.255.LT	0B	13.0	9.1	0.4	22.0
GCA.0E.255.LT	0K	17.0	14.1	0.5	27.5
GCA.2S.255.LT	2B	20.0	15.2	0.5	32.0
GCA.2E.255.LT	2K	25.0	20.2	0.5	39.0
GCA.3S.255.LT	3B	25.0	18.2	0.5	39.0
GCA.4S.255.LT	4B	35.0	25.6	0.6	50.0
GCA.4E.255.LT	4K	35.0	30.6	0.6	50.0
GCA.5S.255.LT	5B	42.0	35.1	0.3	57.5

- Material: CuSnZn plated brass (2 µm)

Tooling

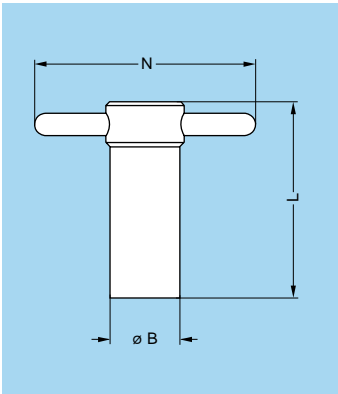

DCG Spanners for hexagonal nuts

Part number	Series	Dim. (mm)			Part number of the nut
		B	L	N	
DCG.91.149.0TN	00	14	40	50	GEA.00.240.LN
DCG.91.161.1TN	0B	16	45	52	GEA.0S.240.LN
DCG.91.231.7TN	2B	23	62	68	GEA.2S.240.LN
DCG.91.282.2TN	3B	28	76	73	GEA.3S.240.LN

● Material: Blackened steel

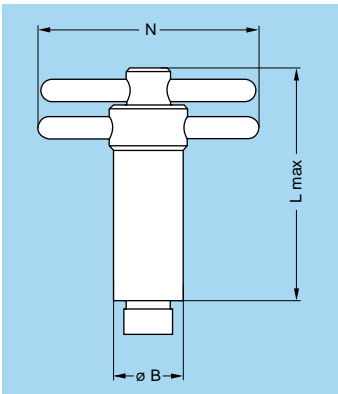
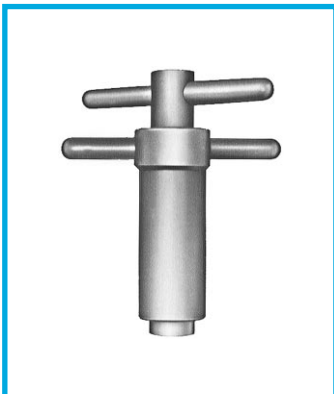

DCA Spanners for hexagonal nuts, with alignment of the sockets by the flats

Part number	Series	Dim. (mm)			Part number of the nut
		B	L	N	
DCA.91.149.0TN	00	14	65	50	GEA.00.240.LN
DCA.91.161.1TN	0B	16	73	52	GEA.0S.240.LN
DCA.91.231.7TN	2B	23	100	68	GEA.2S.240.LN
DCA.91.282.2TN	3B	28	120	73	GEA.3S.240.LN

● Material: Blackened steel

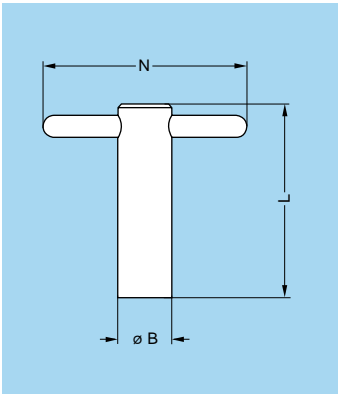
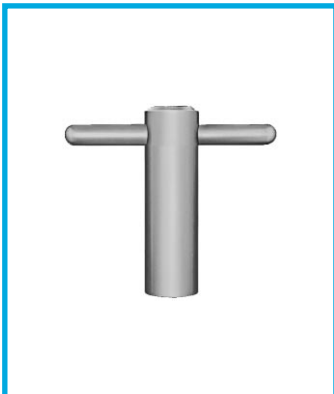

DCB Spanners type wrench for Model 1 round nuts

Part number	Series	Dim. (mm)			Part number of the nut
		B	L	N	
DCB.91.119.0TN	00	11	40	50	GEB.00.240.LN
DCB.91.131.1TN	0B	13	45	50	GEB.0S.240.LN
DCB.91.201.8TN	2B	20	62	65	GEB.2S.240.LN
DCB.91.242.2TN	3B	24	76	70	GEB.3S.240.LN

● Material: Blackened steel

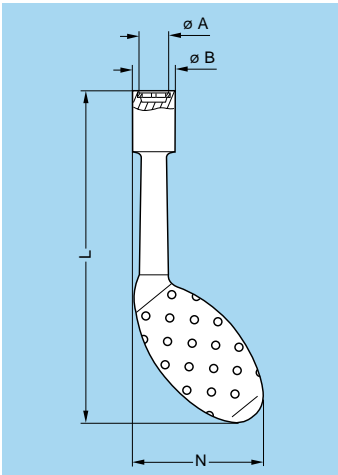

DCH Spanners for conical nut

Part number	Series	Dimensions (mm)				Part number of the nut
		A	B	L	N	
DCH.91.101.PN	00	10.1	12.8	124	48.3	GEC.00.240.LC
DCH.91.121.PN	0B	12.1	14.8	124	49.3	GEC.0S.240.LC
DCH.91.201.PN	2B	20.1	22.8	129	53.5	GEC.2S.240.LC

● Material: Dark grey polyurethane

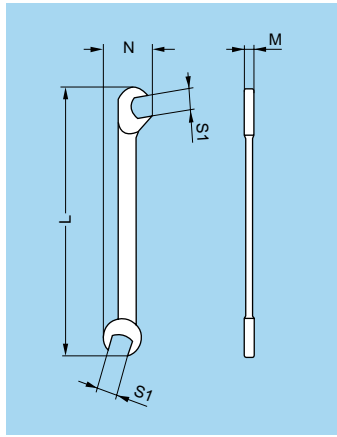
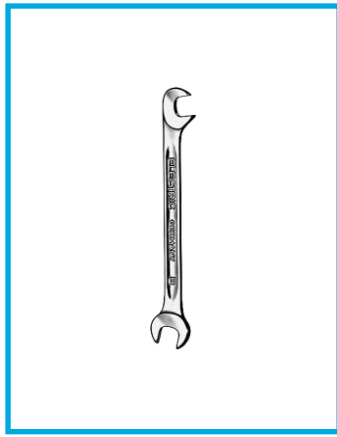

DCP Flat spanners for collet nut

Part number	Series	Dimensions (mm)			
		L	M	N	S1
DCP.99.045.TC	00	70	2	10.5	4.5
DCP.99.050.TC	00	78	2	12.6	5.0
DCP.99.055.TC	00	78	2	12.6	5.5
DCP.99.060.TC	00	78	2	12.6	6.0

- Material: Chrome-plated steel

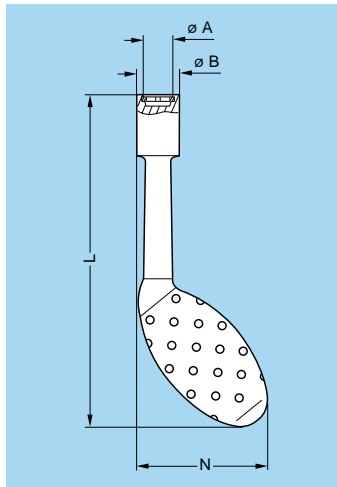

DCH Spanners for notched nuts

Part number	Series	Dimensions (mm)				Part number of the nut
		A	B	L	N	
DCH.91.101.PA	00	10.1	12.8	124	48.3	GEG.00.240.LC
DCH.91.121.PA	0B	12.1	14.8	124	49.3	GEG.0S.240.LC
DCH.91.181.PA	0K	18.1	22.8	129	53.1	GEG.0E.240.LC
DCH.91.201.PA	2B	20.1	22.8	129	53.5	GEG.2S.240.LC
DCH.91.251.PA	2K	25.1	32.8	134	55.5	GEG.2E.240.LC

- Material: Blue polyurethane

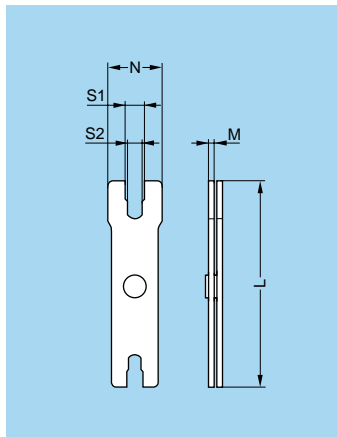

DCP Spanners for tightening collet nut

Part number	Series	Dimensions (mm)				
		L	M	N	S1	S2
DCP.91.001.TN	0B	95	2.5	21	8.1	7.1
DCP.91.023.TN	2B-2K	115	3.0	30	13.1	12.1
	3B-3K	115	3.0	35	15.1	14.1
DCP.91.045.TN	4B	130	3.5	40	21.2	20.2
	5B	130	3.5	45	31.2	30.2

- Material: Blackened steel

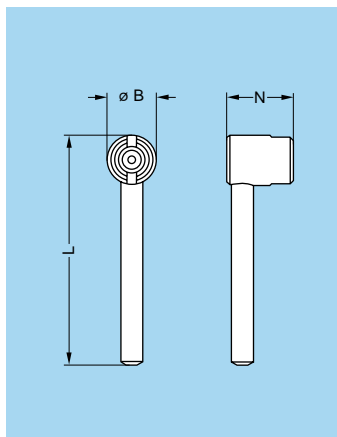

DCL Spanners for securing straight plug with two latching tabs while tightening collet nut

Part number	Series	Dimensions (mm)		
		B	L	N
DCL.91.105.0TK	00	10	45	13.5

- Material: Blackened steel



DPF Pliers for assembling plugs (series K)

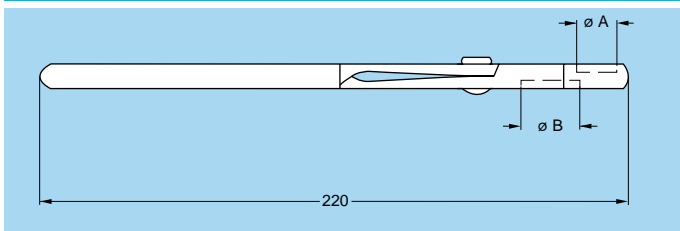

Part number	Series	Dimensions (mm)	
		A	B
DPF.91.001.TA	0K	10	–
DPF.91.023.TA	2K	15	–
	3K	–	18

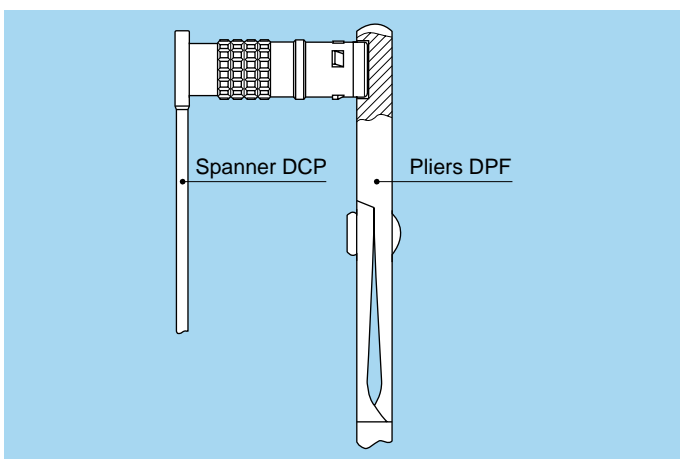

Example for use

The plug end must be held in the pliers while the nut is tightened with the spanner.

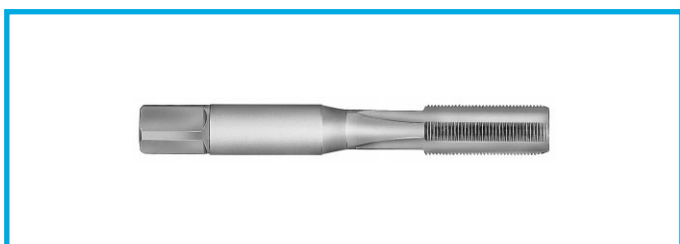

DTA Taps

Part number	Series	Thread
DTA.99.700.5Z	00	M7 x 0.5
DTA.99.900.6Z	0B	M9 x 0.6

Fig. 1

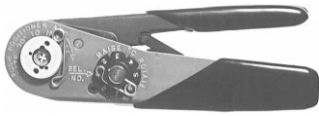
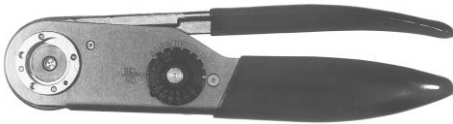

Fig. 2



Manual crimping tools

Supplier	Part number	
	contact \varnothing 0.7-0.9-1.3 (Fig. 1)	contact \varnothing 1.6-2.0 (Fig. 2)
LEMO	DPC.91.701.V ¹⁾	DPC.91.101.A ²⁾
DANIELS	MH860 ¹⁾	AF8 ²⁾
BALMAR	23-000	55-000
BUCHANAN	616336 ¹⁾	615708 ²⁾

¹⁾ According to specification MIL-C-22520/7-01.

²⁾ According to specification MIL-C-22520/1-01.



male



female

These positioners are suitable for use with manual crimping tool according to the MIL-C-22520/7-01 standard.

DCE Positioners for crimp contacts \varnothing 0.7, 0.9 and 1.3 mm

	Connector				Positioners part number	
	Type		\varnothing Contact	Conductor AWG	For male contact	For female contact
	F1	F2				
2B 2K	96A	92A	0.9	20-22-24	DCE.91.092.BVC	DCE.91.092.BVM
	96C	92C				
	96E	92E	0.7	22-24-26	DCE.91.072.BVC	DCE.91.072.BVM
	96J	92J				
3B 3K	97C	93B	0.9	20-22-24	DCE.91.093.BVC	DCE.91.093.BVM
	97E	93E				
	-	87E	0.7	22-24-26	DCE.91.073.BVC	DCE.91.073.BVM
	97J	93J				
	97R	93R				
	96X	92X				
-	87R					
4B 4K	-	95D	1.3	18-20	DCE.91.134.BVC	DCE.91.134.BVM
	-	93E		1.3 ¹⁾	18-20	DCE.91.133.BVCY
	-	-	0.9	20-22-24	DCE.91.094.BVC	DCE.91.094.BVM
	97F	-				
	-	-	1.3	18-20	DCE.91.134.BVC	DCE.91.134.BVM
	-	-				
	-	-	0.9	20-22-24	DCE.91.094.BVC	DCE.91.094.BVM
	97R	93R				
	97L	93L	0.9	20-22-24	DCE.91.094.BVC	DCE.91.094.BVM
	98L	94L				
	97T	93T	0.7	22-24-26	DCE.91.074.BVC	DCE.91.074.BVM
	-	88E				
99H	-					
98E	94E					

Note: ¹⁾ Arrangement with special contact length, special positioners are required.



These turrets are suitable for use with manual crimping tool according to the MIL-C-22520/1-01 standard.

Note: A wide variation of strand number and diameter combinations are quoted as being AWG, some of which do not have a large enough cross section to guarantee a crimp as per either MIL-C-22520/1 or /7-01. Our technical department is at your disposal to study and propose a solution to all your specific problems.

DCE Turrets for crimp contacts \varnothing 1.6 and 2.0 mm

	Connector				Turret part number	
	Type		\varnothing Contact	Conductor AWG	For male contact	For female contact
	F1	F2				
5B 5K	-	94B	2.0	12-14-16	DCE.91.205.BVCM	DCE.91.205.BVCM
	-	956		2.0 ¹⁾	12-14-16	DCE.91.203.BVCM
	-	90C	1.6 ¹⁾	14-16-18	DCE.91.164.BVCM	DCE.91.162.BVCM

Note: ¹⁾ Arrangement with special contact length, turret from another series are required.

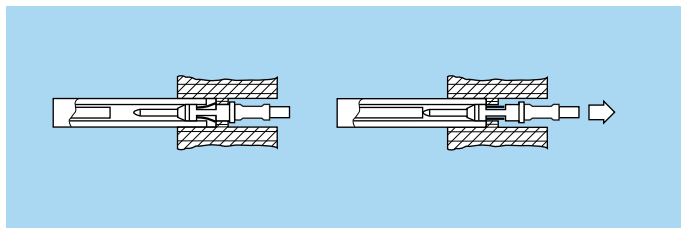
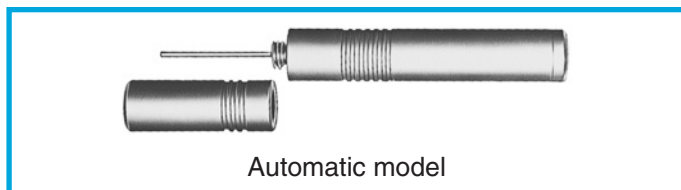
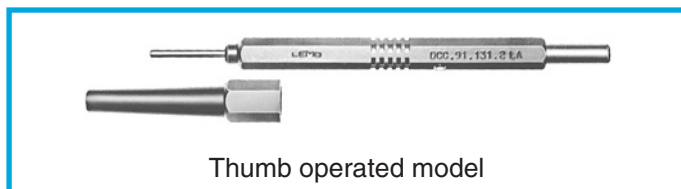

DCC Extraction tools for crimp contacts

	FO Contact		ø A Contact	Extractor	
	Types			Thumb operated model	Automatic model
	F1	F2			
2B 2K	96A	92A	0.9	DCC.91.090.5LA	DCF.91.090.2LT
	96C	92C	0.7	DCC.91.070.5LA	DCF.91.070.2LT
	96E	92E			
	96J	92J			
3B 3K	97C	93B	0.9	DCC.91.090.5LA	DCF.91.093.5LT
	97E	93E	0.7	DCC.91.070.5LA	DCF.91.073.5LT
	-	87E			
	97J	93J			
	97R	93R	0.9	DCC.91.131.5LA	DCF.91.133.5LT
	96X	92X			
-	87R				
-	95D				
4B 4K	-	93E	1.3	DCC.91.131.5LA	DCF.91.133.5LT
	-	-	0.9	DCC.91.090.5LA	DCF.91.093.5LT
	97F	-	1.3	DCC.91.131.5LA	DCF.91.133.5LT
	-	-	0.9	DCC.91.090.5LA	DCF.91.093.5LT
	97R	93R	0.9	DCC.91.090.5LA	DCF.91.093.5LT
	97L	93L			
	98L	94L			
	97T	93T	0.7	DCC.91.070.5LA	DCF.91.073.5LT
	-	88E			
	99H	-			
	98E	94E			
	5B 5K	-	94B	2.0	DCC.91.202.5LA
-		956	2.0	DCC.91.202.5LA	DCF.91.203.5LT
-			1.6	DCC.91.162.5LA	DCF.91.163.5LT
-		90C	1.6	DCC.91.162.5LA	DCF.91.163.5LT

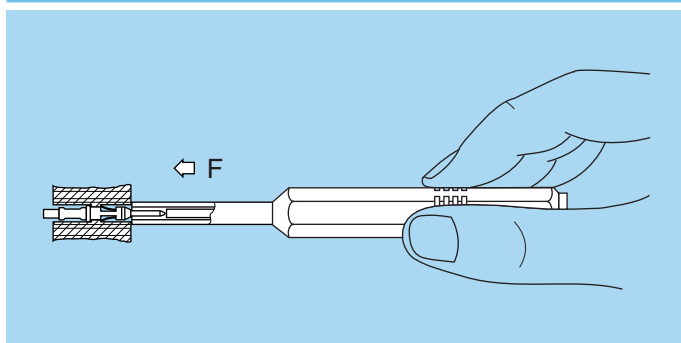
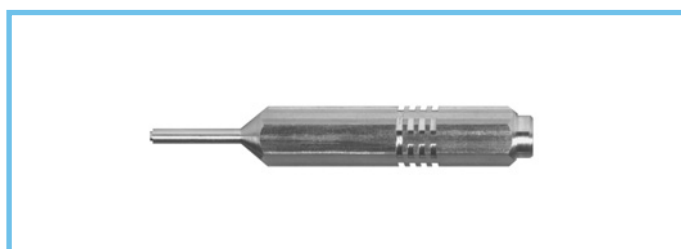

DCK Retention testing tools for crimp contacts ø 0.7, 0.9 and 1.3 mm

Contact ø A	Test force (N)	Testing tool part number	
		For male contact	For female contact
0.7	10	DCK.91.071.0LRC	DCK.91.071.0LRM
0.9	14	DCK.91.091.4LRC	DCK.91.091.4LRM
1.3	25	DCK.91.132.5LRC	DCK.91.132.5LRM

Tools for type C Coaxial Contacts

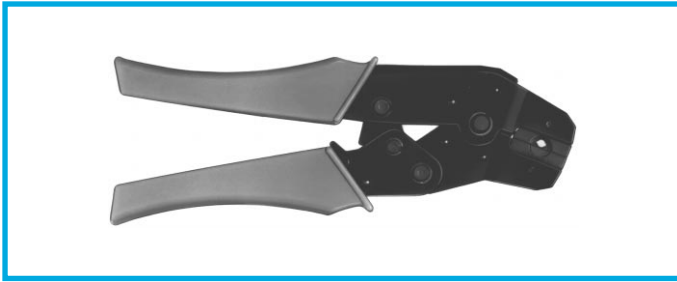

DPE Crimping tool with die

Part number	Cable group
DPE.99.103.1K	2
DPE.99.103.8K	1, 3

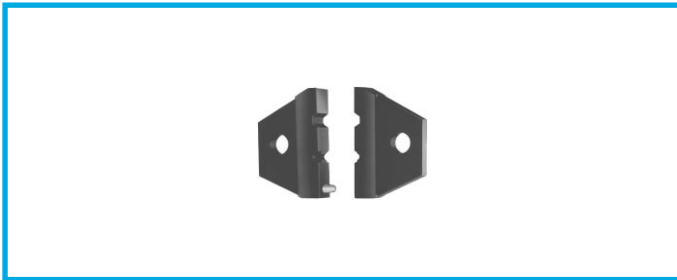

DPN Dies

Part number	Cable group	Die dimensions					
		For contacts			For shield		
		A	B	L	A	B	
DPN.99.103.1K	2	1.09	0.77	2.0	3.10	2.70	
DPN.99.103.8K	1, 3	1.09	0.77	2.0	3.80	3.30	

- Die material: Blackened steel

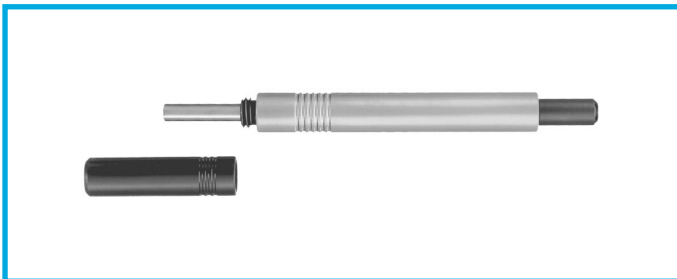
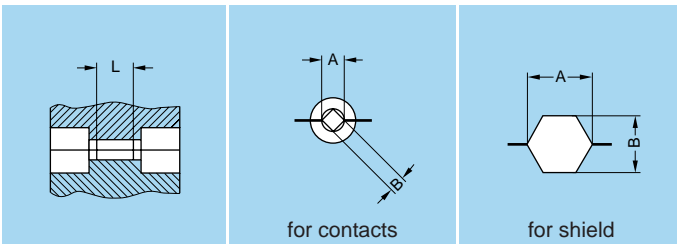

DCC Extractors

Part number	Cable group
DCC.91.384.5LA	1, 2, 3

Fibre Optic Tooling

We propose a complete range of tools for fibre optic connector cable assembly. Some tools are specific to each fibre optic contact type. When selecting necessary tooling, make sure you identify correctly the contact type used in the selected product.



DRV Complete workstation for fibre optic contact

Description

Comprehensive range of tools for terminating both single-mode and multi-mode fibres. Includes specific tools for F2 and F4 fibre optic contacts. Detachable termination case lid for use as polishing platform during field termination. Rugged but aesthetically pleasing termination case which is ideal for field use or in-house terminations. Curing oven and inspection microscope shall be ordered separately.

Part number	Contact type
DRV.91.CF2.PN	F2, F4

Workstation Contents

Part Number	Description	Quantity	Number
WST.BT.175.55PT	Plastic box	1	1
WST.BR.150.8AC	Tweezers	1	2
WST.CH.252.5SR	Lint-free Cloth	1	3
WST.CS.125.CE	Kevlar cutters	1	4
WST.CO.020.52	Cotton bud (sachet of 20 pcs)	1	5
WST.DS.290.PT	Alcohol dispenser (supplied empty)	1	6
DCC.91.312.5LA	Extraction tool for F1 and F2 contacts	1	7
DCS.91.G20.0C	Microscope adapter for F2 and F4 cont.	1	8
WST.ME.354.8R	Epoxy mixer and pad	1	9
DOC.FO.CF2.0000	Terminating instructions for F2 contacts	1	10
WST.OU.135.10SZ	Fibre scribe	1	11
DCS.91.F24.LC	Polishing tool for F2 and F4 contacts	1	12
WST.OU.452.5MN	Large cable stripper	1	13
WST.PA.105.5525	Cleaning tissues	1	14
WST.PA.012.AOJ	Lapping film 12µm (yellow)	20	15
WST.PA.005.AOM	Lapping film 5µm (brown)	20	16
WST.PA.001.AOV	Lapping film 1µm (green)	20	17
WST.PN.210.AS	Armoured cable cutter	1	18
WST.PN.145.AR	Cable cutter	1	19
WST.PN.103.OPG	Outer jacket stripper	1	20
WST.PN.203.CR	Buffer coating stripping tool	1	21
WST.PN.102.3CR	Primary coat stripper	1	22
DPE.99.524.337K	Crimp tool	1	23
WST.PL.322.5PT	Polishing platform	1	24
WST.RE.353.EPO	Epoxy resin + safety instructions	10	25
WST.SE.305.8PH	Syringe with needle	10	26
WST.TU.191.LN	Fibre shield for F2 and F4 contacts	4	27
WST.RG.150.AZ	Steel rule 6"	1	28
WST.SY.135.PA	Fibre length marking pen	1	29
WST.CS.155.AZ	Scissors	1	30

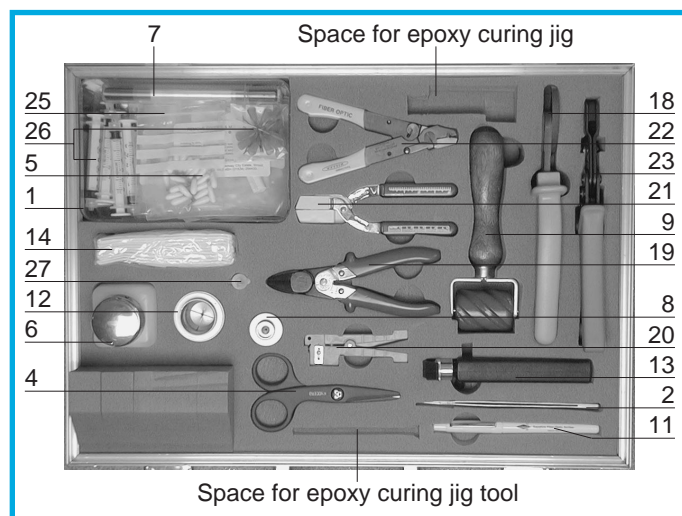
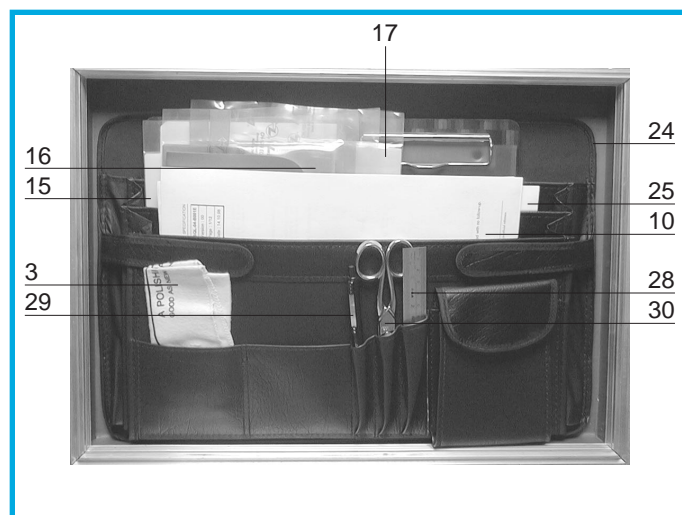

Note: The interior of the case is fitted with pre-formed plastic foam to provide secure storage of the tools.



DPE Crimping tool for fibre optic contact

Description

Crimping tool for capturing KEVLAR® strand on contact body

Part number	Contact type
DPE.99.524.337K ¹⁾	F1, F2, F3, F4

Note: ¹⁾ Included in the LEMO F2 workstation.

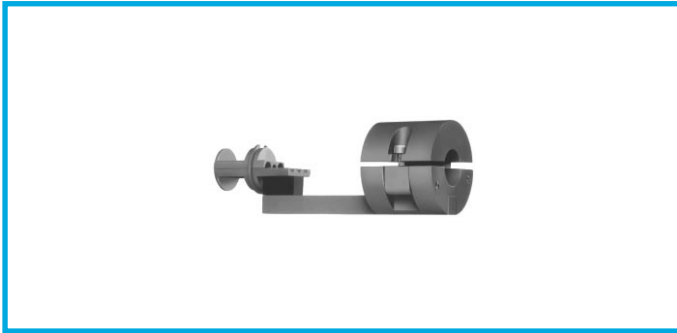
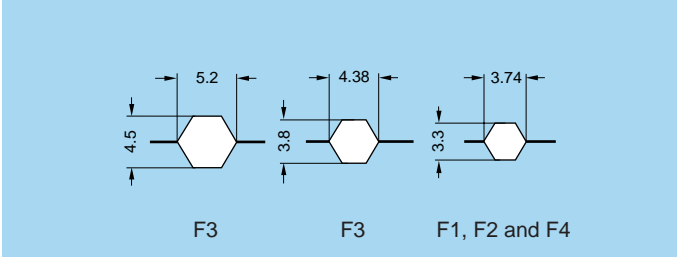

DCS Epoxy curing jig

Description

Curing positioning jig specifically designed to ease assembly of the 3K.93C series with associated camera cable

Part number	Contact type
DCS.91.F12.3LA	F2



WST Epoxy curing oven

Description

Oven for assisting in curing epoxy

Part number	Voltage	Contact type
WST.FR.220.VA	220 volts	F1, F2, F3, F4
WST.FR.110.VA	110 volts	



DCS Polishing tool for fibre optic contacts

Description

Precision spring loaded tool for polishing terminated fibre optic contacts.

Part number	Contact type
DCS.91.F13.LC	F1, F3
DCS.91.F24.LC ¹⁾	F2, F4

Note: ¹⁾ Included in the LEMO F2 workstation.



WST Fibre Inspection Microscope

Description

Microscope to assist in viewing termination operations and verifying fibre end finish.
See adaptor below.

Part number	Contact type
WST.FB.G10.4N	F1, F2, F3, F4

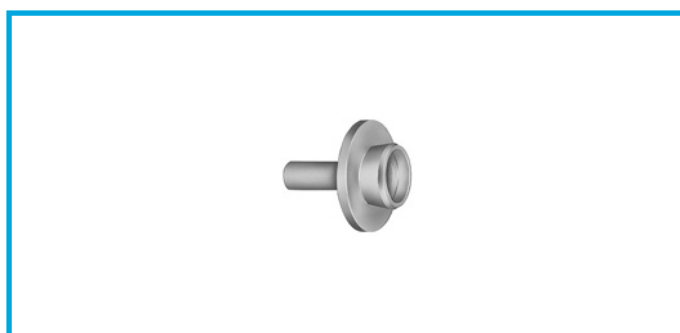

DCS Microscope adaptor for fibre optic contacts

Description

Adaptor for final inspection of fibre optic contacts.
To be used with microscope WST.FB.G10.4N

Part number	Contact type
DCS.91.G24.0C	F1, F3
DCS.91.G20.0C ¹⁾	F2, F4

Note: ¹⁾ Included in the LEMO F2 workstation.

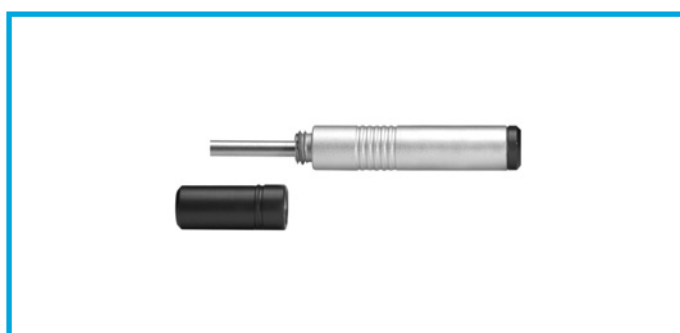

DCC Extractor for fibre optic contact

Description

Tool for extracting the F1 or F2 contact.

Part number	Contact type
DCC.91.312.5LA ¹⁾	F1, F2

Note: ¹⁾ Included in the LEMO F2 workstation.



DCS F2 contact alignment device installation/extraction tool

Description

Simple tool with two threaded end for installation/extraction of the F2 contact alignment device

Part number	Contact type
DCS.F2.035.PN	F2

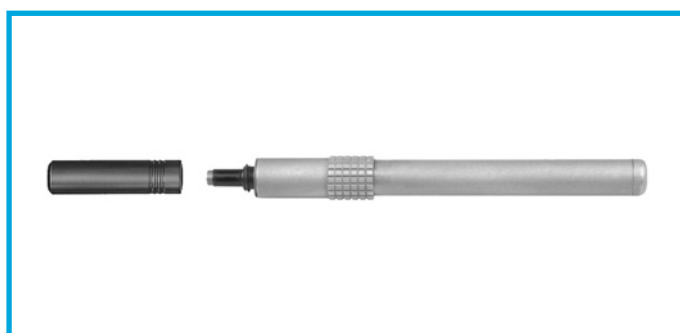

DCC F4 contact alignment device extraction tool

Description

This tool is for extraction/reinstallation of the F4 contact alignment device. It is necessary for contact cleaning only

Part number	Contact type
DCC.F4.125.7LA	F4

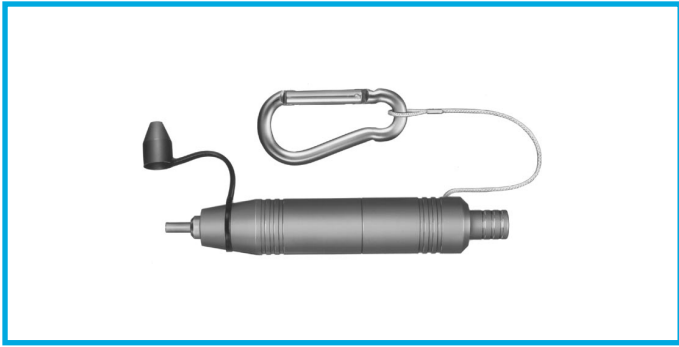

DCS Cleaning tool

Description

Used for maintenance cleaning. The tool is made with an alcohol spongy reservoir (supplied empty).
16 dry cotton buds are included.
The threaded end allows extraction/reinstallation of the F2 contact alignment device.

Part number	Contact type
DCS.91.F23.LA	F2



WST Cleaning kit

Description

Kit that includes 2 cotton buds one of them moistened with alcohol

Part number	Contact type
WST.KI.125.34	F1, F2, F3, F4

Technical characteristics

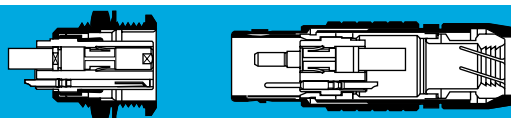

Outer shell

Brass

In most cases, LEMO connectors have a brass outer shell which is suitable for most general purpose applications, including civilian and military. The brass outer shells have a chrome nickel-plated surface which ensures very good protection against industrial atmosphere, salt air and most corrosive agents.

Alternative protective coatings are available to satisfy other specific environmental conditions:

- electrolytic nickel
- nickel-black chrome. After the black chrome treatment, the part is coated with a protective organic film.

Stainless steel

For applications where there are severe environmental conditions that may rapidly damage the surface finish, we recommend using stainless steel. The AISI 303 stainless steel is a material for general use adapted to most applications requiring a product made entirely of stainless metal.

For the broadcasting industry the heavy duty line with shell in stainless steel offers more resistance to heavy wear conditions.

Aluminium alloy

The aluminium alloy outer shells find numerous applications where light weight is a predominant factor, such as in the aeronautics and space industries, and for portable and mobile equipment.

These materials have high mechanical strength and excellent resistance to corrosion.

The shell surface is protected by anodizing which is available in six colours: blue, yellow, black, red, green, and natural.

Depending on the application, other surface finish is also available (electrolytic nickel-plating, black nickel plating).

Plastic materials

Some connector model shells of the 2B-4B series can be made of plastic. This solution offers optimum electrical insulating properties particularly suitable for medical applications.

Grey or white polysulfone (PSU) and beige PEEK offer excellent mechanical properties and is suitable for gas or vapour sterilization.

Some models are also available with an outer shell of cream-coloured polyphenylsulfone (PPSU). We recommend this material particularly for applications where products are to withstand hundreds of vapour sterilization cycles.

Other metallic components

In general, most metallic components are manufactured in brass. However, bronze or beryllium copper are used where good elasticity is required (for example: grounding crown). Depending on the application, these parts have electrolytic nickel or nickel-gold plating. These parts can also be manufactured in stainless steel (AISI 416).

Gasket and O-rings

In general, gaskets and O-rings are made of silicone rubber MQ/MVQ. However, for some products they are made of fluorosilicone rubber (FPM).

Technical characteristics of plastic materials

Type	Norme	Units	PEEK	PSU	PPSU	Silicone	FPM
Density	ASTM D 792	–	1.3-1.4	1.24	1.3	~1.2	~1.9
Tensile strength (at 23°C)	ASTM D 638/ ISO R527	MPa	92-142	70	70	> 9	> 12
Flexural strength (at 23°C)	ASTM D 790/ ISO R178	MPa	170	106	91	–	–
Dielectric strength	ASTM D 149/IEC 60243	kV/mm	19-25	17-20	15	18-30	–
Volume resis. at 50% HR and 23°C	ASTM D 257/IEC 60093	$\Omega \bullet \text{cm}$	10^{16}	5×10^{16}	–	10^{14}	–
Surface resistivity	ASTM D 257	Ω	10^{15}	–	–	–	–
Thermal conductivity	ASTM C 177	W/K \bullet m	0.25	0.26	–	–	–
Comparative tracking index	IEC 60112	V	CTI 150	CTI 150	–	–	–
Maxi. continuous service temperature	UL 746	°C	250	140	180	200	200
Min. continuous service temperature	UL 746	°C	-55	-60	-50	-50	-20
Max. short-time service temperature	–	°C	300	160	200	> 250	300
Water absorption in 24h at 23°C	ASTM D 570/ISO R62A	%	0.12	0.3	0.37	–	–
Radiation resistance	–	Gy ¹⁾	10^7	10^5	–	10^5	8×10^4
Flammability rating	ASTM D 635/UL 94	–	V-0/3.2	V-0/4.4	V-0/1.6	–	–
Resistance to steam sterilization	–	–	excel.	good	excel.	good	good

ASTM = American Society for Testing & Materials
 ISO = International Standards Organization
 UL = Underwriters Laboratories
 IEC = International Electrotechnical Commission

Note: ¹⁾ 1 Gy (Gray) = 100 rad

Materials and Treatments

Component	Material (Standard)	Surface treatment (µm)								Notes
		chrome			nickel			black chr.		
		Cu	Ni	Cr	Cu	Ni	Ni	Cr		
Outer shell, collet nut, conical nut or notched nut	Brass (UNS C 38500)	0.5	3	0.3	0.5	3	1	2		
	Stainless steel (AISI 303 or 304)	without treatment								
	Aluminium alloy (AA 6262A or AA 6023)	anodized								
	PEEK, Polyether EtherKetone, beige	-								1)
	PSU (Udel®), Polysulfone, grey or white	-								2)
Grounding crown	PPSU (Radel®), Polyphenylsulfone, cream	-								2)
	Bronze (UNS C 54400) or special brass	-	-	-	0.5	3	-	-		
Latch sleeve	Stainless steel (AISI 416)	without treatment								3)
	Special brass	0.5	3	0.3	0.5	3	-	-		
Locking washer	Stainless steel (AISI 416)	without treatment								3)
	Bronze (UNS C 52100)	-	-	-	0.5	3	-	-		
Hexagonal or round nut	Brass (UNS C 38500)	-	-	-	0.5	3	-	-		
	Stainless steel (AISI 303 or 304)	without treatment								4)
	Aluminium alloy (AA 6262A or AA 6023)	anodized natural								4)
Other metallic components	Brass (UNS C 38500)	-	-	-	0.5	3	-	-		
	Stainless steel (AISI 303 or 304)	without treatment								
O-ring and gaskets	Silicone MQ/MVQ or FPM/FKM (Viton®)	-								

Notes:

standards for surface treatment are as follows:
 Chrome-plated: FS QQ-C-320B;
 Nickel-plated: FS QQ-N-290A, or MIL-C-26074C;
 Gold-plated: ISO 4523; and
 Black chrome: MIL-C-14538C with a minimum of 10 µm of lacquer protection.

- 1) for FGG and ENG models of the 3B and 4B series
- 2) for the FGY and ENY models of the 2B, 3B and 4B series
- 3) AISI 416 steel is used with shells made of AISI 303 or 304
- 4) delivered with free and fixed sockets with aluminium alloy or stainless steel shell

Shell electrical continuity:

(measured according to IEC 60512-2 test 2f)

- Test current: 1A

	Series							
	2B	3B	4B	5B	2K	3K	4K	5K
R (mΩ)	2.2	2.2	1.5	1.5	1.8	1.6	1.4	1.4

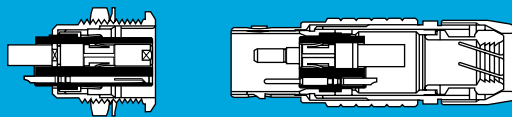

Insulator

LEMO uses PEEK (Polyether Etherketone) for the insulator material. The performance of this thermoplastic material is enhanced by the addition of glass fibres in the resin to achieve very high mechanical strength, to

increase dielectric strength and to reduce water absorption rate. The above features of PEEK plus its excellent radiation resistance makes it ideal for most applications. (See technical characteristics on page 107)

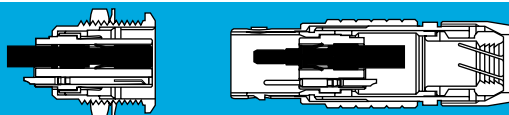

Fibre Optic Contacts

In order to ensure the highest technical performance and to provide the optimal solution for a diversity of applications, LEMO has developed the 4 types of fibre optic contacts designated F1, F2, F3, and F4.

F2 and F4 contacts are designed with fully floating pre-domed ceramic ferrule. Such contacts are mainly designed to operate with single-mode and multi-mode fibres with small core dimensions.

F1 and F3 contacts are using floating metallic or ceramic ferrules. They are ideal for use with multi-mode, silica or plastic fibres with large core diameters.

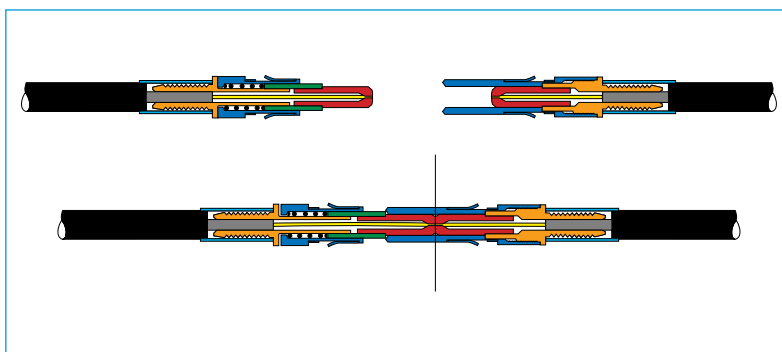

Contact F1

- Contact body: part ensuring the alignment of the two ferrules and retention of the contact into the insulator, made of rust-proof alloy. Clips is made of Cu-Be
- Crimp holder: provided for cable fixing, made of rustproof alloy
- Ferrule made of rustproof alloy or ceramic depending on the fibre diameter
- Ferrule holder made of rustproof alloy
- Stainless steel spring to guarantee mating precision of the two ferrules lengthwise
- Crimp ferrule made of Nickel-plated copper for fixing the cable onto the crimp holder
- Fibre
- Buffer
- Cable

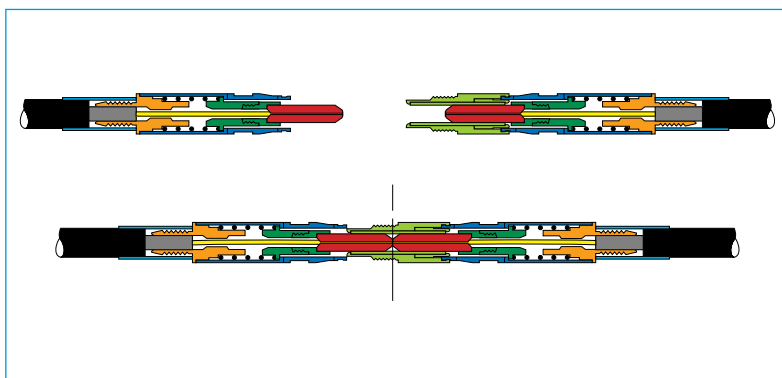

Contact F2

- Contact body: part ensuring the retention of the contact into the insulator, made of PEEK
- Crimp holder: provided for cable fixing, made of Nickel-plated brass
- Ferrule made of ceramic
- Ferrule holder made of rustproof alloy
- Stainless steel spring to guarantee physical contact of the two ferrules with correct pressure
- Crimp ferrule made of Nickel-plated copper for fixing the cable onto the crimp holder
- Alignment tube to guarantee the alignment of the two ferrules when mated, made of ceramic and rustproof alloy
- Fibre
- Buffer
- Cable

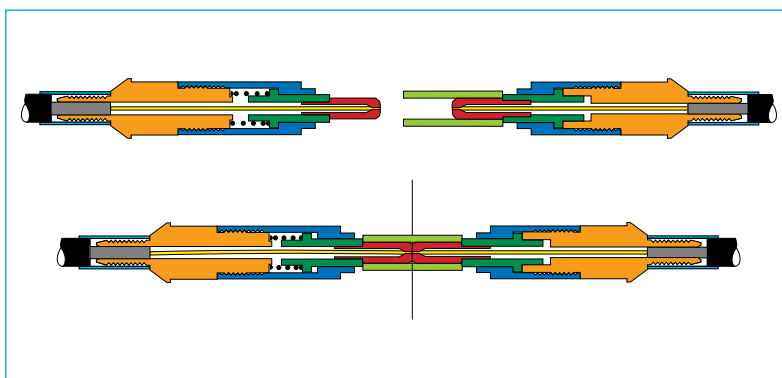

Contact F3

- Contact body: part ensuring the alignment of the contact into connector shell, made of Nickel-plated brass
- Crimp holder: provided for cable fixing, made of Nickel-plated brass
- Ferrule made of rustproof alloy or ceramic depending on the fibre diameter
- Ferrule holder made of rustproof alloy
- Stainless steel spring to guarantee mating precision of the two ferrules lengthwise
- Crimp ferrule made of Nickel-plated copper for fixing the cable onto the crimp holder
- Alignment tube to guarantee the alignment of the two ferrules when mated, made of rustproof alloy
- Fibre
- Buffer
- Cable

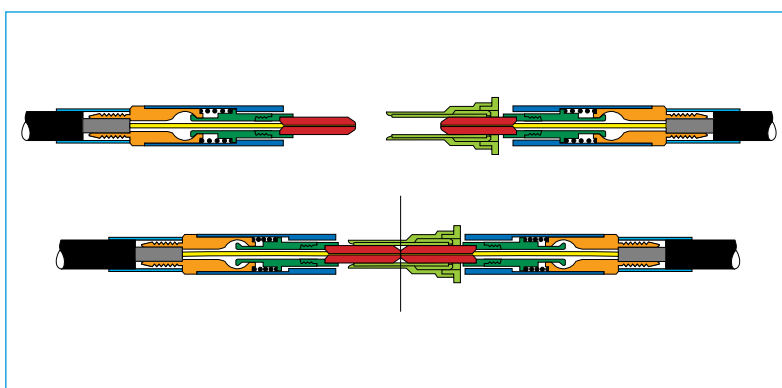

Contact F4

- Contact body: part ensuring the alignment of the contact into connector shell, made of rustproof alloy
- Crimp holder: provided for cable fixing made of Nickel-plated brass
- Ferrule made of ceramic
- Ferrule holder made of rustproof alloy
- Stainless steel spring to guarantee physical contact of the two ferrules with correct pressure
- Crimp ferrule made of Nickel-plated copper for fixing the cable onto the crimp holder
- Alignment tube to guarantee the alignment of the two ferrules when mated (always fitted into the fixed or free socket) made of ceramic and rustproof alloy
- Fibre
- Buffer
- Cable

Optical Performance for F1, F2, F3, and F4 Type Contacts

The optical performance for the fibre optic contacts relates to the insertion and return losses measured at the junction of the fibre to fibre interface. These losses are caused mainly by minute geometrical effects of the critical alignment components and deviations in the fibre core and cladding dimensions.

The insertion loss results for multi-mode and single-mode fibres are given whereas the return loss values are provided for single-mode fibres only.

Insertion and return losses are expressed in decibels (dB). The data shown in the diagrams below correspond to numerous matings using various batches of optical fibres and connectors.

Measurements with Single-mode Fibre for F2 and F4 Contacts.

Insertion loss

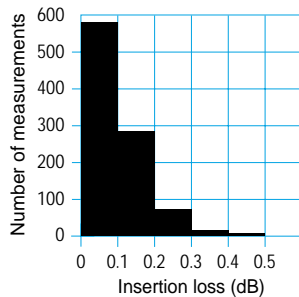

Mean = 0.10 dB
 Tested at 1300 nm
 Tested according to the standard IEC 61300-03-04,
 Insertion Method B.
 Fibre = 9/125 μm
 Ferrule bore diameter = 125 μm

Return loss

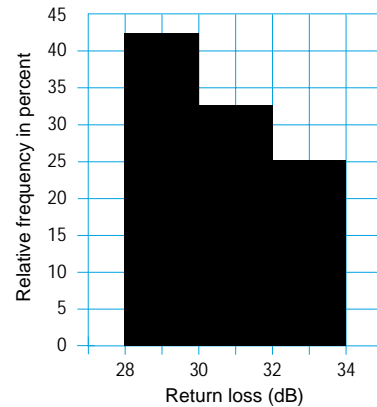

Mean = 30.42 dB
 Tested at 1300 nm
 Tested according to the standard IEC 61300-03-06,
 Branching Device Method
 Fibre = 9/125 μm , Hand Polishing

Note: It is possible to obtain return losses better than 45 dB with UPC polishing techniques. Please consult LEMO for more detailed information.

Measurements with Multi-mode Fibre for F2 and F4 Contacts

Insertion loss

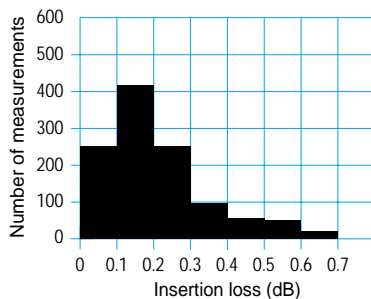

Mean = 0.25 dB
 Tested at 1300 nm
 Tested according to the standard IEC 61300-03-04,
 Insertion Method B.
 Fibre = 50/125 μm
 Ferrule bore diameter = 126 μm

Measurements with Multi-mode Fibre for F1 and F3 Contacts

Insertion loss

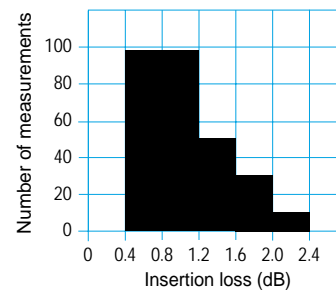

Mean = 1.13 dB
 Tested at 850 nm
 Tested according to the standard IEC 61300-03-04,
 Insertion Method B.
 Fibre = 200/230 μm
 Ferrule bore diameter = 235 μm

Change in attenuation vs. environmental and mechanical conditions

Characteristic	Value	Standard	Change in attenuation ¹⁾	
			F2-F4 Contacts	F1-F3 Contacts
High temperature	+ 80°C	IEC 61300-02-18	< 0.20 dB	< 0.20 dB
Low temperature	- 40°C	IEC 61300-02-17	< 0.20 dB	< 0.20 dB
Change of temperature (7 cycles)	Diagram 1 below	IEC 61300-02-22	< 0.20 dB	< 0.20 dB
Damp heat steady state	Up to 95 % RH, 60°C	IEC 61300-02-19	< 0.20 dB	< 0.15 dB
Mating cycles (contact F1; F2; F3)	1000	IEC 61300-02-02	< 0.15 dB	< 0.15 dB
Mating cycles (contact F4)	500	IEC 61300-02-02	< 0.15 dB	–
Cable retention ²⁾	100 N	IEC 61300-02-04	< 0.10 dB	–
Impact (Method A)	1 m onto concrete floor	IEC 61300-02-12	< 0.10 dB	< 0.15 dB
Shock (3 cycles in 2 directions)	100 g, 10-50 ms; 20 g, 6-9 ms	IEC 61300-02-09	< 0.10 dB	< 0.20 dB
Vibration (7 cycles)	Diagram 2 below	IEC 61300-02-01	< 0.20 dB	< 0.25 dB

Note:

¹⁾ The insertion loss variations were measured during the entire environmental and mechanical tests respectively.

²⁾ Value quoted is for 2.5 mm tight jacket cable. In practice the cable retention depends on many factors including the cable construction.

Diagram 1: Temperature cycles

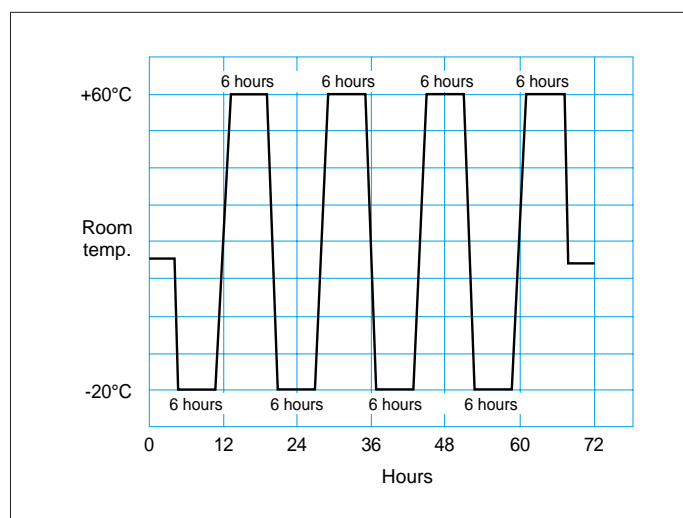
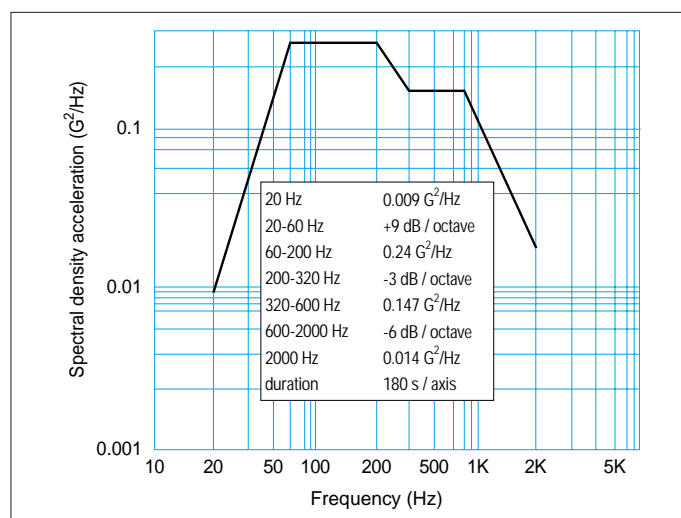
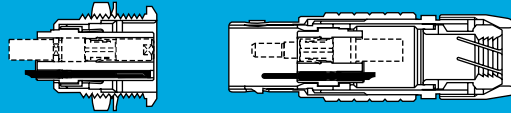

Diagram 2: Vibration





Electrical Contact

Technical description

The secure reliable electromechanical connection achieved with LEMO female cylindrical contacts is mainly due to two important design features:

1. *Prod proof entry* on the mating side which ensures perfect concentric mating even with carelessly handled connectors; and
2. *The pressure spring*, with good elasticity, maintains a constant even force on the male contact when mated. The leading edge of the pressure spring preserves the surface treatment (gold-plated) and prevents undue wear.

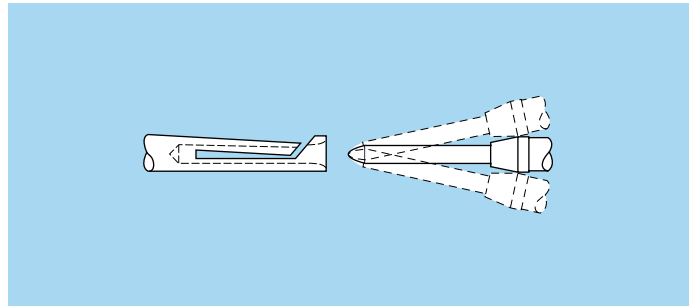

Contact material and treatment

LEMO female contacts are made of bronze (UNS C 54400). This material is chosen because of its high modulus of elasticity, its excellent electrical conductivity and a high mechanical strength.



LEMO male solder contacts are made of brass (UNS C 38500). Male crimp contacts are made of brass (UNS C 34500) or annealed brass (UNS C 38500) with optimum hardness (HV) for crimping onto the wire.

Type	Material (standard)	Surf. treatment (µm)		
		Cu	Ni	Au ¹⁾
Male crimp	Brass (UNS C 34500)	0.5	3	1.0
	Brass (UNS C 38500)			
Male solder	Brass (UNS C 38500)			
Female crimp	Bronze (UNS C 54400)	0.5	3	1.5
Female solder				
Clips	Cu-Be (FS QQ-C-530)	-	-	-
	Stainless steel			

Notes: The standard surface treatment are as follows:
 Nickel: FS QQ-N-290A or MIL-C-26074C; and Gold: ISO 4523.
¹⁾ Minimum value.

Thickness comparison between the outside and the inside of female contacts

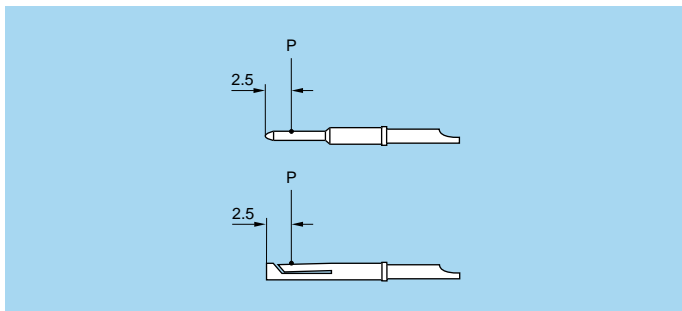

Contact ø A (mm)	Gold thickness		
	male (µm)	female	
		outside (µm)	inside (%)
0.7	1.0	1.5	70
0.9	1.0	1.5	75
1.3	1.0	1.5	75
1.6	1.0	1.5	75
2.0	1.0	1.5	75
4.0	1.0	1.5	75

Note: P = inspection point

Contact resistance with relation to the number of mating cycles

(measured according to IEC 60512-2 test 2a)

Maximum values measured after the mating cycles and the salt spray test according to IEC 60512-6 test 11f.

ø A (mm)	Contact resistance (mΩ)			ø A (mm)	Contact resistance (mΩ)		
	1000 cycles	3000 cycles	5000 cycles		1000 cycles	3000 cycles	5000 cycles
0.7	5.6	5.7	6.1	1.6	2.6	2.7	3.5
0.9	4.1	4.2	4.8	2.0	2.9	3.1	3.3
1.3	2.8	2.9	3.6	4.0	1.6	2.0	2.8

Insulation resistance between the contacts and contact/shell

(measured according to IEC 60512-2 test 3a)

Insulating material	PEEK
new	> 10 ¹² Ω
after humidity test ¹⁾	> 10 ¹⁰ Ω

Note: ¹⁾ 21 days at 95% RH according to IEC 60068-2-3.

Solder contacts

The conductor bucket of these contacts is machined at an angle to form a cup into which the solder can flow.

See page 9 for the range of cable dimensions that can be soldered.

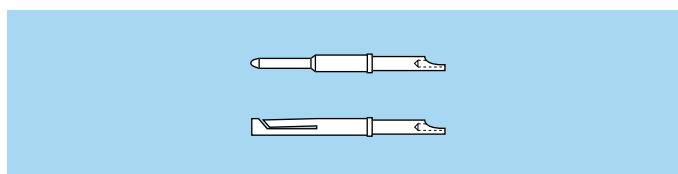

Crimp contacts

For multipole or hybrid connectors the standard four-identifier crimp method is used (MIL-C-22520F, class I, type 1).

The crimp method requires a controlled compression to obtain a symmetrical deformation of the conductor strand and of the contact material. The radial hole in the side of the contact makes it possible to check whether the conductor is correctly positioned within the contact. A good crimping is characterized by only slightly reduced conductor section and practically no gap.

For optimum crimping, the bronze or brass contacts are annealed to relieve internal stress and reduce material hardening during the crimping process.

Only the crimping zone is annealed with the help of an induction heating machine designed by the LEMO Research and Development Department.

Advantages of crimping

- practical, quick contact fixing outside the insulator
- possible use at high temperature
- no risk of heating the insulator during the conductor-contact fixing
- high tensile strength

Crimp contacts are available in standard version for mounting maximum size conductors.

For some dimensions, these crimp contacts can be produced with reduced crimp barrels for mounting reduced size conductors. Consult the factory for information.

The range of cable dimensions that can be crimped into the contacts is indicated on the table on page 9.

Coaxial contacts type C

The cable fixing is achieved with hexagonal crimping (MIL-C-22520F, type 2). This method guarantees a good electrical continuity of the shield which improves greatly the shielding efficiency of the cable/connector link. The back end of the crimp nut which receives the shield braid, is milled to ensure a good retention of the shield once crimped.

For the center contact, square form crimp method is used (MIL-C-22520F, type 2). The method requires a controlled compression to obtain a symmetrical deformation of the conductor strand and of the contact material.

The radial hole in the side of the contact enables correct positioning of the conductor within the contact to be verified. A good crimping is characterized by a small conductor section reduction and by the quite closed free spaces.

The LEMO crimp contacts are factory annealed to relieve internal stresses, and reduce the risk of the material work hardening during the crimping process.

Technical characteristics

Characteristics	Unit	Value
Impedance	Ω	50
Operating voltage at 50 Hz ¹⁾	kV rms	0.5
Test voltage at 50 Hz	kV rms	1.6
Rated current	A	2
Insulation resistance	Ω	$>10^{12}$
Contact resistance	m Ω	5.8
Shell to shell resistance	m Ω	3.7
VSWR (f=GHz)		1.04 + 0.1f
Max. working frequency	GHz	2.1

Standing wave ratio

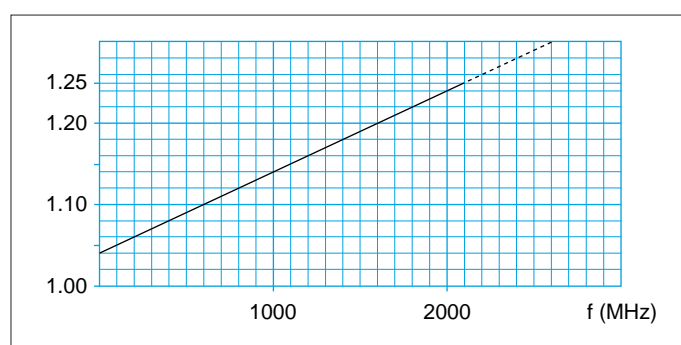

The range of coaxial cables that can be crimped into the contacts is indicated on the table on page 9.

Test voltage

Test voltage (U_e):
(measured according to the IEC 60512-2 test 4a standard).

It corresponds to 75% of the mean breakdown voltage.
Test voltage is applied at 500 V/s and the test duration is one minute.

This test has been carried out with a mated plug and receptacle, with power supply only on the plug end.

Operating voltage (U_s):
It is proposed according to the following ratio: $U_s = \frac{U_e}{3}$

Caution:
For a number of applications, safety requirements for electrical appliances are more severe with regard to operating voltage.

In such cases operating voltage is defined according to creepage distance and air clearance between live parts.

Please consult the factory for the choice of a connector by indicating the safety standard to be met by the product.

Voltage values are given in the table on insulator types for each series corresponding with values measured at sea level and are adapted to all applications up to an altitude of 2000 m.

In case a device is used at a higher altitude, air clearance between live parts has to be multiplied by the following coefficients:
(Test voltage also has to be divided by this coefficient).

altitude (m)	coefficient
2000	1.00
3000	1.14
4000	1.29
5000	1.48

Rated current

(measured according to IEC 60512-3 test 5a).

The specified rated current can be applied simultaneously to all the contacts, corresponding with an average temperature rise of 40°C of the connector.

The current values are indicated in the table of insulator types in each series. For use at higher temperatures, acceptable rated current will be lower.
It tends towards zero as the material is used at the maximum operating temperature accepted for the insulator.

In most cases, the current depends on the conductor dimension.

Caution: In general, connectors should not be unmated while live.

For connectors with PEEK insulator, maximum admissible current will follow the curve below depending on the operating temperature T.

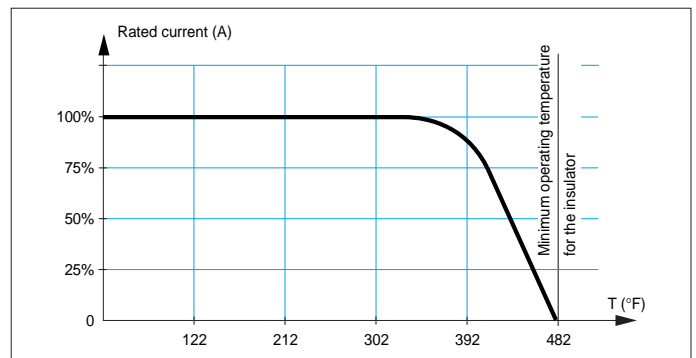



Cable fixing

Cable fixing onto LEMO connectors is determined by the cable characteristics and the connector model. This is achieved either with a cable collet system, by epoxy into a cable adapter or by hexagonal crimping (MIL-C-22520F).

Material and Treatment

Component	Material (Standard)	Surface Treatment (µm)	
		Cu	Ni
Center piece	Brass (UNS C 38500)	0.5	3
Collet	Brass (UNS C 38500)	0.5	3
Crimp ferrule or ring	Copper (UNS C 18700)	0.5	3
Reducer	Brass (UNS C 38500)	0.5	3
Reducing cone	Brass (UNS C 38500)	0.5	3
Earthing cone	Brass (UNS C 38500)	0.5	3
Metal washer	Brass (UNS C 38500)	0.5	3
Cable adapter	Brass (UNS C 38500)	0.5	3
Support tube	Stainless steel (AISI 304)	-	
Anchor	Stainless steel (AISI 303)	-	
Earthing body	Brass (UNS C 38500)	0.5	3
Gasket or o-ring	Silicone MQ/MVQ	-	
	FPM (Viton®)		

Notes:

Standards for surface treatment are as follows: Nickel-plated: FS QQ-N-290A.

Cable fixing for 00 and 0B series

In this series of single fibre connectors the fibre optic cables are held onto the contacts using the hexagonal crimping technique. The cable strength member (aramid yarn) is retained between the knurled section of the contact ④ and the crimp ferrule ②. The support tube ⑤ is used to protect the delicate optical fibre from the crimping load. Buffer coated fibres are retained into the fibre optic contact using an epoxy technique (Type T). The fibre optic contact is retained into the connector with the collet nut ①.

00 Series

Type E fixing (crimp)

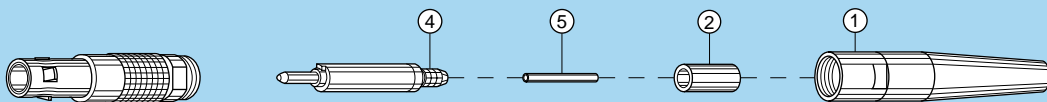

00 Series

Type T fixing (epoxy)

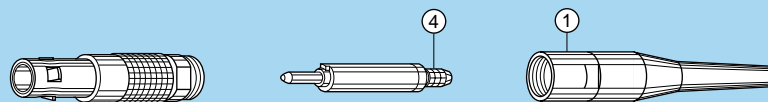

0B Series

Type E fixing (crimp)

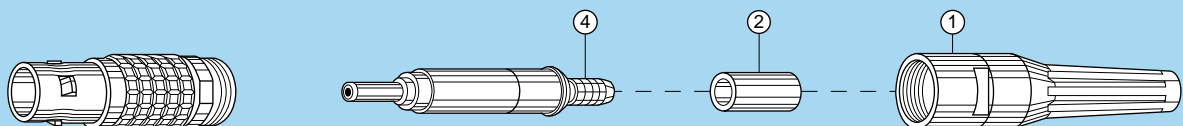

Cable fixing for 0K series

In this series of single fibre the fibre optic cable is held onto the contact using the hexagonal crimping technique. The cable strength member (aramid yarn) is retained between the knurled section of the contact ④ and the crimp ferrule ②. Then the contact is inserted into the adapter ⑤ and is retained because of its special shape. The adapter with its fibre optic contact is retained into the connector with the collet nut ①.

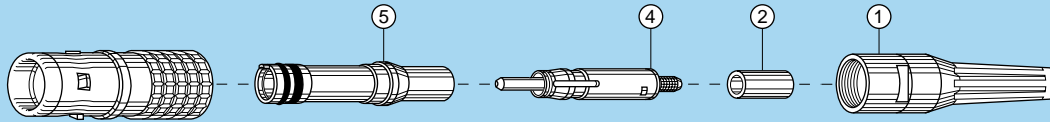

Cable clamping for 2B-3B-4B and 5B series

Type D cable clamping

This is the standard cable clamping for 2B, 3B, 4B, and 5B series. Two split insert carriers ④ position the insulator into the connector and a collet ② which is compressed by the collet nut ① ensures a good grip onto the cable. When assembling the connector, the cable shield is clamped between the split insert carrier and the collet.

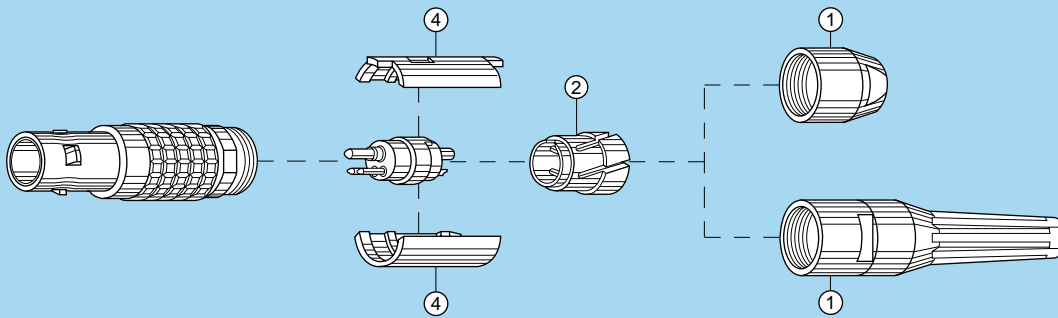

Type M cable clamping

This clamping system is adapted to cables with a diameter smaller than the smallest diameter specified for each series. It includes a reducer ⑫, a collet of a smaller series ② and a reducing cone ⑪. These parts have the same function as the D type collet.

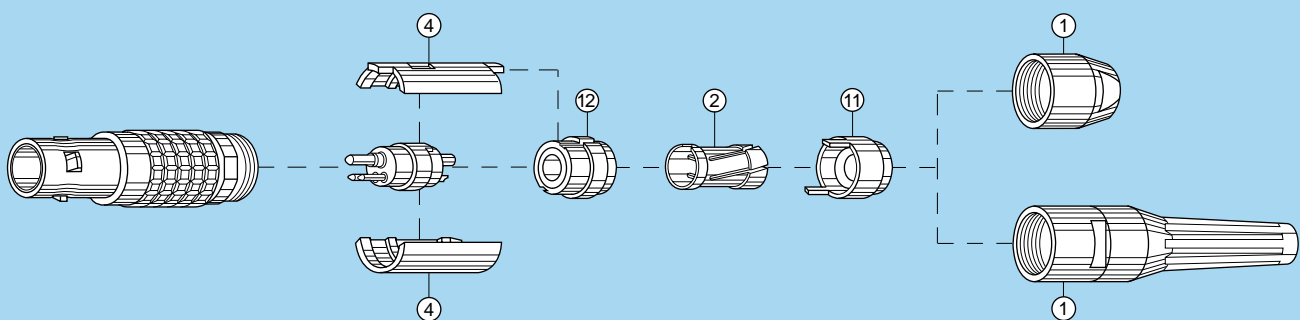

Cable fixing for 2K-3K-4K and 5K series

Type T clamping

In the watertight series the clamping system is made of a cable adapter ② which is fixed on the cable by epoxy. This solution offers superior captivation of the cable strength member (aramid yarn) and is fully watertight. The adapter is completed by a sealing o-ring ③. The insulator is positioned into the cable adapter and is correctly oriented by the split insert carrier ④. The system is retained into the connector by the collet nut with its bend relief. For some specific cables (3K.93C series) an anchor ⑥ is installed to allow retention of the cable center steel strength member. For screened cable, the shield can be soldered to the cable adapter front section.

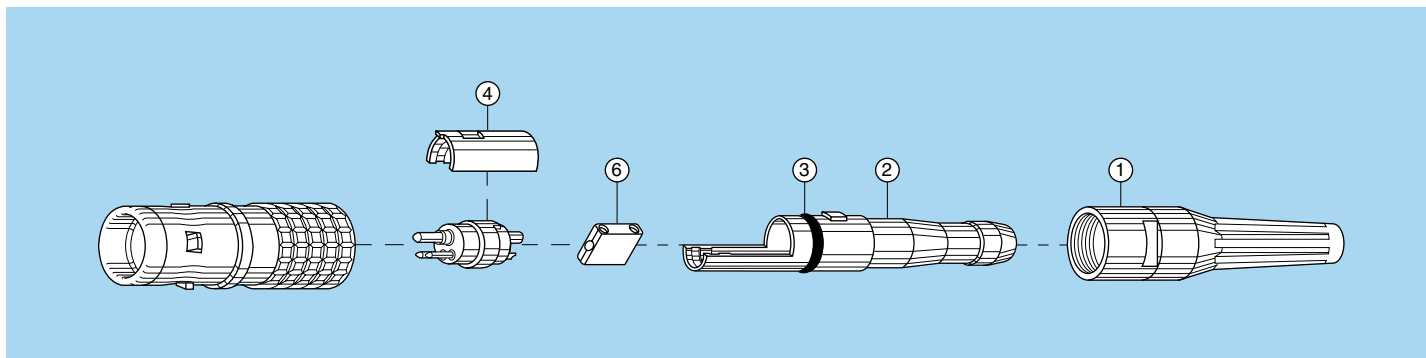

Cable clamping for the model FUW and PUW of the 3K.93C series

Type C clamping

For these 2 models the clamping is made of a collet ② located into the extender ⑩ and compressed by the collet nut ① to ensure a good grip onto the cable. A gasket, inside of the collet, provides sealing onto cable jacket. Additioned sealing is made with epoxy. To guarantee enhanced screen efficiency the shield of the cable is retained between the knurled section of the earthing body ⑦ and the crimp ring ⑤. The insulator is positioned into the two insert carrier ④. The anchor ⑥ is installed to allow retention of the cable center steel strength member.

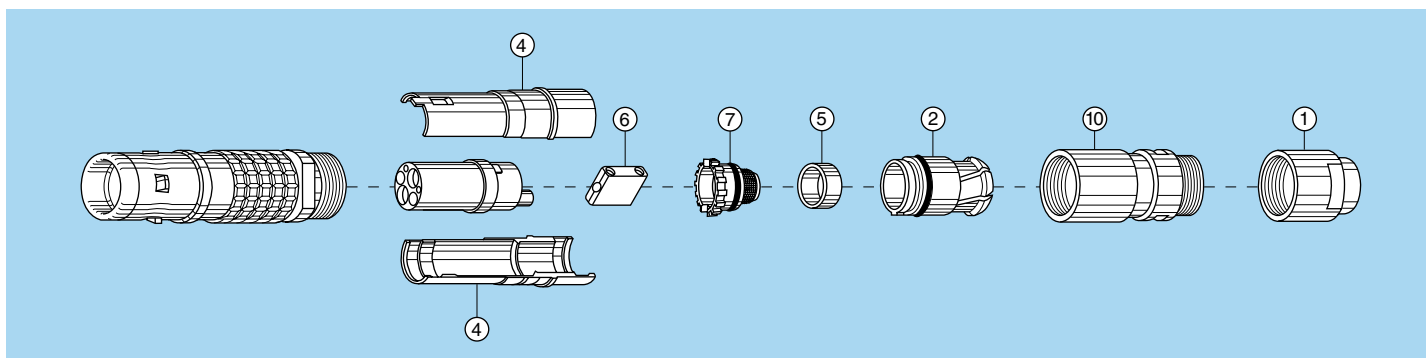

Maximum metal collet nut tightening torque

	Series										
	00	0B	0K	2B	3B	4B	5B	2K	3K	4K	5K
Torque (Nm)	0.25	0.5	0.7	2.5	4	7	10	2	3	5	8

Maximum plastic collet nut tightening torque ¹⁾

	Series		
	2B	3B	4B
Torque (Nm)	0.50	1.00	1.50

Note: ¹⁾ For applications subject to strong vibration, we recommend fixing the collet nut with epoxy resin.

Preferred fibre optic cable types

The preferred and very common cable construction for use with LEMO connectors are shown below.

- Simplex semi-tight jacket cables between 2 and 3 mm in diameter and have straight lay Kevlar® reinforcement (see fig. 1).
- 900 micron plastic buffered fibres (see fig. 2).
- Multiway «break-out» cables which have additional overall straight lay Kevlar® to provide cable pull resistance (see fig. 3).
- Multiway «premise» cables with 900 micron plastic buffered fibres and additional overall straight lay Kevlar® to provide cable pull resistance (see fig. 4).

Fig. 1



Fig. 2



Fig. 3

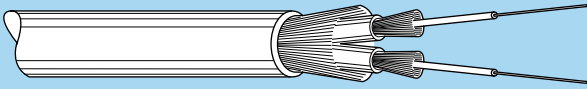
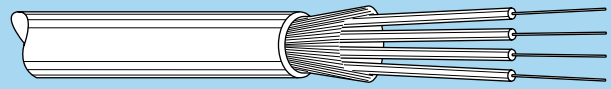

Fig. 4



For other cable construction it is recommended that you contact us directly for advice on their suitability for termination onto LEMO connectors.



Компания «ЭлектроПласт» предлагает заключение долгосрочных отношений при поставках импортных электронных компонентов на взаимовыгодных условиях!

Наши преимущества:

- Оперативные поставки широкого спектра электронных компонентов отечественного и импортного производства напрямую от производителей и с крупнейших мировых складов;
- Поставка более 17-ти миллионов наименований электронных компонентов;
- Поставка сложных, дефицитных, либо снятых с производства позиций;
- Оперативные сроки поставки под заказ (от 5 рабочих дней);
- Экспресс доставка в любую точку России;
- Техническая поддержка проекта, помощь в подборе аналогов, поставка прототипов;
- Система менеджмента качества сертифицирована по Международному стандарту ISO 9001;
- Лицензия ФСБ на осуществление работ с использованием сведений, составляющих государственную тайну;
- Поставка специализированных компонентов (Xilinx, Altera, Analog Devices, Intersil, Interpoint, Microsemi, Aeroflex, Peregrine, Syfer, Eurofarad, Texas Instrument, Miteq, Cobham, E2V, MA-COM, Hittite, Mini-Circuits, General Dynamics и др.);

Помимо этого, одним из направлений компании «ЭлектроПласт» является направление «Источники питания». Мы предлагаем Вам помощь Конструкторского отдела:

- Подбор оптимального решения, техническое обоснование при выборе компонента;
- Подбор аналогов;
- Консультации по применению компонента;
- Поставка образцов и прототипов;
- Техническая поддержка проекта;
- Защита от снятия компонента с производства.



Как с нами связаться

Телефон: 8 (812) 309 58 32 (многоканальный)

Факс: 8 (812) 320-02-42

Электронная почта: org@eplast1.ru

Адрес: 198099, г. Санкт-Петербург, ул. Калинина, дом 2, корпус 4, литера А.