

Triple DPDT, Low-Capacitance Data Switches

General Description

The MAX4996/MAX4996L triple DPDT analog switches operate from a single +2.5V to +5.5V supply, and feature 2.0Ω (typ) on-resistance, low 6pF (typ) on-capacitance, and low power-supply current consumption. The MAX4996/MAX4996L combine the low capacitance and low resistance necessary for high-frequency switching applications in portable electronics.

The MAX4996/MAX4996L have three logic inputs to control the switches in pairs. The MAX4996 has an active-high enable input (EN) to disable the switches, while the MAX4996L has an active-low enable input ($\overline{\text{EN}}$) to disable the switches. The enable input decreases the supply current and also places the COM_ outputs in a high-impedance state.

The MAX4996/MAX4996L feature a 5μA (max) supply-current consumption when the logic inputs are not rail-to-rail. This feature is especially valuable in applications where direct interface to low-voltage processors is necessary.

The MAX4996/MAX4996L are available in a space-saving 24-pin (3.5mm x 3.5mm) TQFN package and operate over the -40°C to +85°C temperature range.

Applications

- SD Card Switching
- USB Signal Switching
- UART Signal Switching
- Cell Phones
- PDA's
- GPS
- Portable Media Players (PMP)

Ordering Information

PART	PIN-PACKAGE	PACKAGE CODE
MAX4996ETG+	24 TQFN-EP*	T243A3-1
MAX4996LETG+	24 TQFN-EP*	T243A3-1

Note: All devices operate over the -40°C to +85°C extended temperature range.

+Denotes a lead-free package.

*EP = Exposed paddle.

Typical Operating Circuit appears at end of data sheet.

Features

- ◆ Multiplex SD2.0/SDIO Interfaces
- ◆ Low Power Consumption (2μA max)
- ◆ +2.5V to +5.5V Supply Voltage Range
- ◆ Rail-to-Rail Signal Handling
- ◆ Low-Capacitance Switches, 6pF (typ)
- ◆ Low On-Resistance, 2Ω (typ)
- ◆ Excellent On-Resistance Flatness Over the Range of 0V to V_{CC}
- ◆ Wide -3dB Bandwidth, 670MHz
- ◆ Small 24-Pin TQFN (3.5mm x 3.5mm)

Pin Configuration/Truth Tables

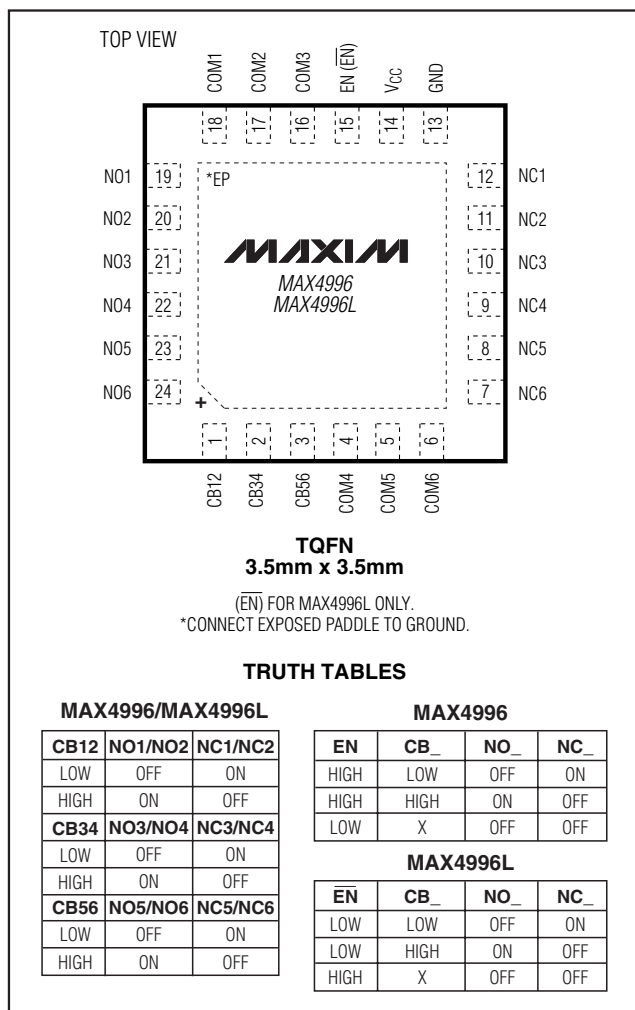

Triple DPDT, Low-Capacitance Data Switches

ABSOLUTE MAXIMUM RATINGS

V _{CC} to GND	-0.3V to +6.0V	Continuous Power Dissipation (T _A = +70°C) 24-Pin TQFN (derate 20.8mW/°C above +70°C)	1228mW
EN, $\overline{\text{EN}}$, CB ₋	-0.3V to +6.0V	Thermal Resistance (Note 1)	
All Other Pins to GND	-0.3V to V _{CC} + 0.3V	θ _{JA}	65.1°C/W
Continuous Current		θ _{JC}	5.4°C/W
NO ₋ , NC ₋ , COM ₋	±150mA	Operating Temperature Range	-40°C to +85°C
Peak Current NO ₋ , NC ₋ , COM ₋		Junction Temperature	+150°C
(pulsed at 1ms, 50% Duty Cycle)	±300mA	Storage Temperature Range	-65°C to +150°C
(pulsed at 1ms, 10% Duty Cycle)	±450mA	Lead Temperature (soldering)	+300°C
ESD per Human Body Model	±2kV		

Note 1: Package thermal resistances were obtained using the method described in JEDEC specification JESD51-7, using a four-layer board. For detailed information on package thermal considerations see www.maxim-ic.com/thermal-tutorial.

Stresses beyond those listed under "Absolute Maximum Ratings" may cause permanent damage to the device. These are stress ratings only, and functional operation of the device at these or any other conditions beyond those indicated in the operational sections of the specifications is not implied. Exposure to absolute maximum rating conditions for extended periods may affect device reliability.

ELECTRICAL CHARACTERISTICS

(V_{CC} = +2.5V to +5.5V, T_A = -40°C to +85°C, unless otherwise noted. Typical values are at V_{CC} = 2.8V, T_A = +25°C.) (Notes 2, 3)

PARAMETER	SYMBOL	CONDITIONS	MIN	TYP	MAX	UNITS
ANALOG SWITCH						
Analog Signal Range	V _{COM} , V _{NO} , V _{NC}		0		V _{CC}	V
On-Resistance	R _{ON}	V _{COM} = 0 to V _{CC} , I _{COM} = 25mA		2	4	Ω
On-Resistance Match Between Channels	ΔR _{ON}	V _{CC} = 2.8V, I _{COM} = 25mA; V _{NO} = 1.5V or V _{NC} = 1.5V (Note 4)		0.1	0.2	Ω
On-Resistance Flatness	R _{FLAT}	V _{CC} = 2.5V, I _{COM} = 25mA; V _{COM} = 0 to V _{CC} (Note 5)		0.2	0.5	Ω
Off-Leakage Current	I _{COM} (OFF)	V _{CC} = 4V, V _{COM} = 0, 4V; V _{NO} , V _{NC} = 4V, 0	-250		+250	nA
		V _{CC} = 5.5V, V _{COM} = 5.5V; V _{NO} , V _{NC} with 50μA sink current to GND			180	μA
On-Leakage Current	I _{COM} (ON)	V _{CC} = 5.5V, V _{COM} = 0, 5.5V; V _{NO} , V _{NC} unconnected	-250		+250	nA
-3dB Bandwidth	BW	R _L = R _S = 50Ω, C _L = 5pF, Figure 4		670		MHz
Off-Isolation	V _{ISO}	f = 1MHz, V _{NO} , V _{NC} = 0; C _L = 5pF, R _L = R _S = 50Ω, Figure 4 (Note 6)		-60		dB
Crosstalk	V _{CT}	f = 1MHz, V _{NO} , V _{NC} = 0; R _L = R _S = 50Ω, Figure 4 (Note 7)		-120		dB
LOGIC INPUTS						
Input Logic High	V _{IH}		1.4			V
Input Logic Low	V _{IL}				0.5	V
Input Leakage Current	I _{LEAK}	0 ≤ V ≤ V _{IL} and V _{IH} ≤ V ≤ V _{CC} ; V _{CC} = 5.5V	-250		+250	nA

Triple DPDT, Low-Capacitance Data Switches

MAX4996/MAX4996L

ELECTRICAL CHARACTERISTICS (continued)

($V_{CC} = +2.5V$ to $+5.5V$, $T_A = -40^{\circ}C$ to $+85^{\circ}C$, unless otherwise noted. Typical values are at $V_{CC} = 2.8V$, $T_A = +25^{\circ}C$.) (Notes 2, 3)

PARAMETER	SYMBOL	CONDITIONS	MIN	TYP	MAX	UNITS
SWITCH DYNAMICS						
Turn-On Time	t_{ON}	$V_{CC} = 2.7V$, $V_{NO_}$ or $V_{NC_} = 1.5V$; $R_L = 50\Omega$, $C_L = 35pF$, Figure 1			100	μs
Turn-Off Time	t_{OFF}	$V_{CC} = 2.7V$, $V_{NO_}$ or $V_{NC_} = 1.5V$; $R_L = 50\Omega$, $C_L = 35pF$, Figure 1			6	μs
Break-Before-Make Interval	t_{BBM}	$V_{CC} = 2.7V$; $V_{NO_}$ or $V_{NC_} = 1.5V$; $R_L = 50\Omega$, $C_L = 35pF$, Figure 2		10		μs
Output Skew Between Switches	t_{SKEW}	$R_L = R_S = 50\Omega$, Figure 3		40		Ps
NO or NC Off-Capacitance	$C_{NO_ (OFF)}$ $C_{NC_ (OFF)}$	$f = 10MHz$, $V_{BIAS} = 0V$, signal = 500mV _{P-P} , Figure 5		2.5		pF
COM Off-Capacitance	$C_{COM_ (OFF)}$	$f = 10MHz$, $V_{BIAS} = 0V$, signal = 500mV _{P-P} , Figure 5		4		pF
COM On-Capacitance	$C_{COM_ (ON)}$	$f = 10MHz$, $V_{BIAS} = 0V$, signal = 500mV _{P-P} , Figure 5		6		pF
Operating Power-Supply Range	V_{CC}		2.5		5.5	V
Shutdown Supply Current		$V_{EN} = 0$ (MAX4996), $V_{\overline{EN}} = V_{CC}$ (MAX4996L)		0.1	0.5	μA
V_{CC} Supply Current	I_{CC}	$V_{CB_} = 0$ or V_{CC} ; $V_{EN} = V_{CC}$ (MAX4996); $V_{\overline{EN}} = 0$ (MAX4996L)	$V_{CC} = 2.8V$	1	2	μA
			$V_{CC} = 5.5V$	5	10	
Increase in Supply Current with $V_{CB_} / V_{EN}$ Voltage		$0 \leq V_{CB_} \leq V_{IL}$ or $V_{IH} \leq V_{CB_} \leq V_{CC}$ or $0 \leq V_{EN} \leq V_{IL}$ or $V_{IH} \leq V_{EN} \leq V_{CC}$			5	μA
ESD Protection		Human Body Model		± 2		kV

Note 2: The algebraic convention is used. The most negative value is shown in the minimum column.

Note 3: Parts are 100% tested at $T_A = +25^{\circ}C$. Limits across the full temperature range are guaranteed by correlation and design.

Note 4: $\Delta R_{ON} = R_{ON(MAX)} - R_{ON(MIN)}$.

Note 5: Flatness is defined as the difference between the maximum and minimum value of on-resistance as measured over the specified analog signal ranges.

Note 6: Off-isolation = $20\log_{10} [V_{COM_} / (V_{NO_} \text{ or } V_{NC_})]$, $V_{COM_}$ = output, $V_{NO_}$ or $V_{NC_}$ = input to off switch.

Note 7: Between any two switches.

Triple DPDT, Low-Capacitance Data Switches

Typical Operating Characteristics

($V_{CC} = 3V$, $T_A = +25^\circ C$, unless otherwise noted.)

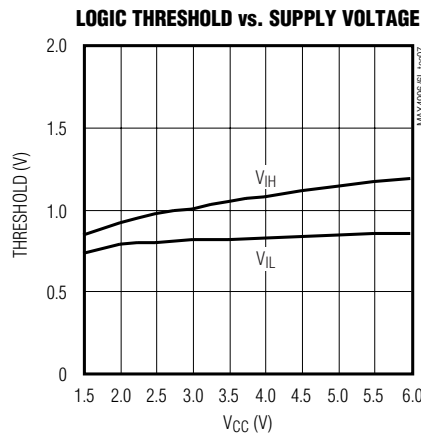
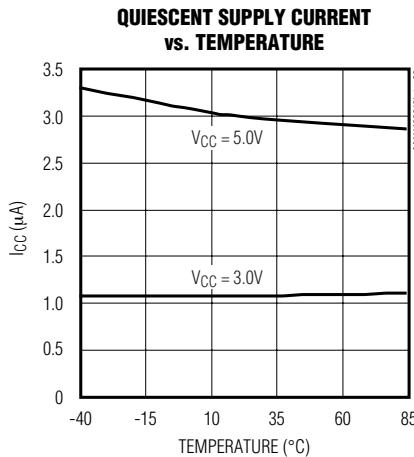
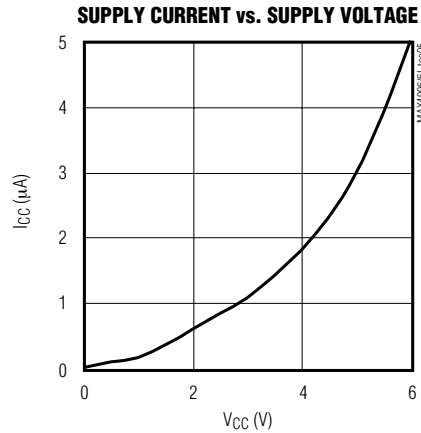
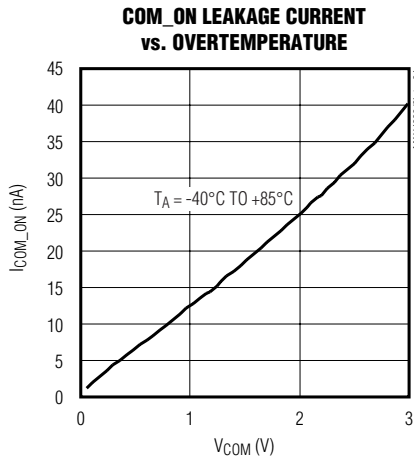
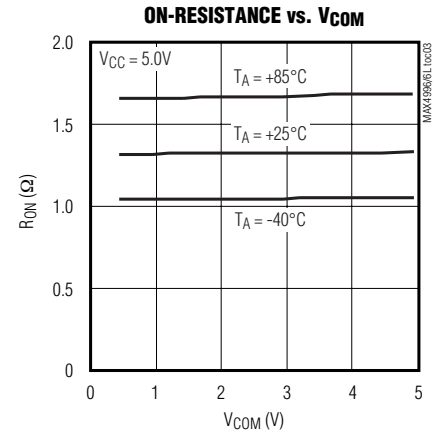
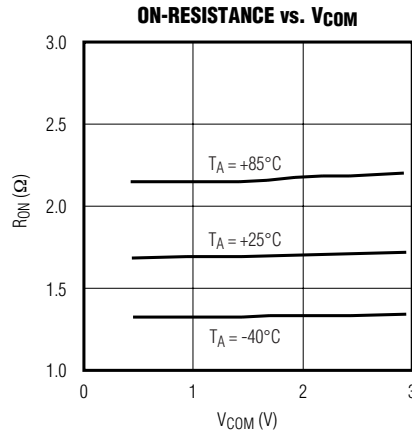
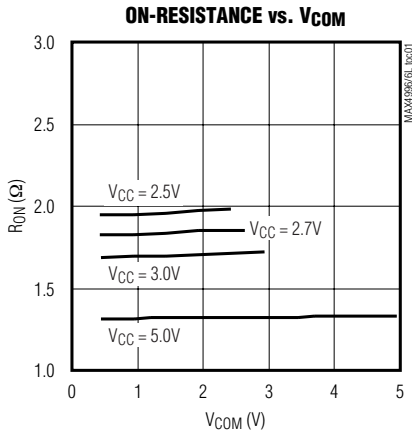

Triple DPDT, Low-Capacitance Data Switches

Typical Operating Characteristics (continued)

($V_{CC} = 3V$, $T_A = +25^\circ C$, unless otherwise noted.)

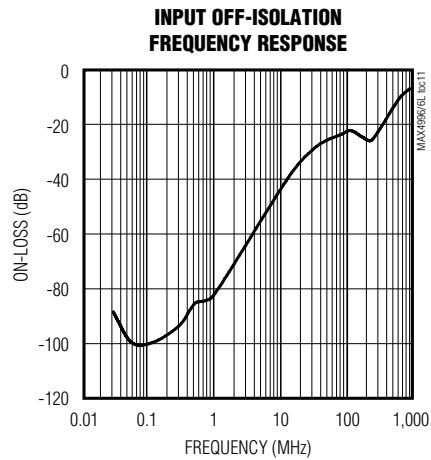
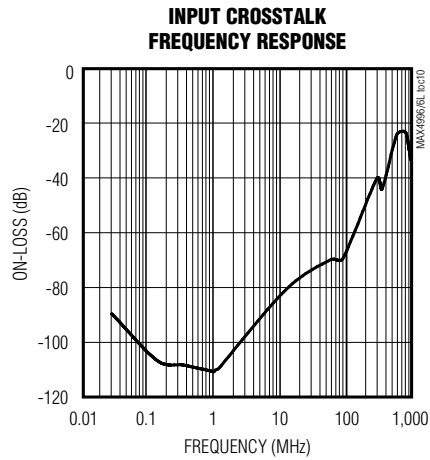
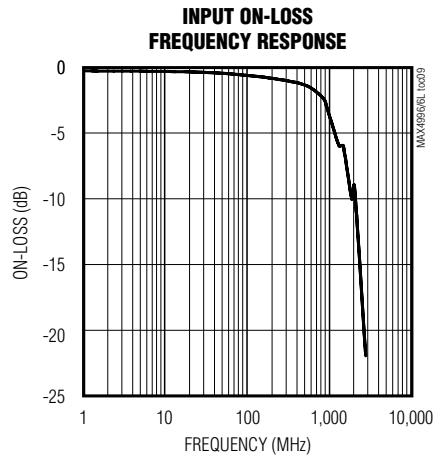
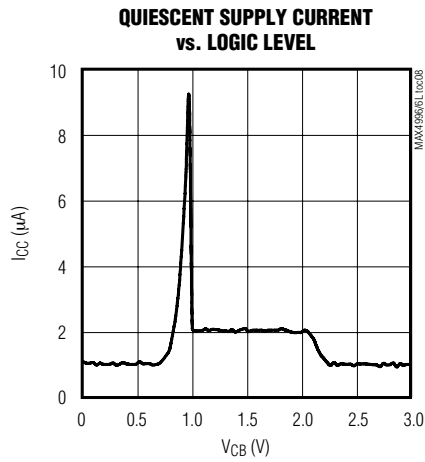

MAX4996/MAX4996L

Triple DPDT, Low-Capacitance Data Switches

Pin Description

PIN	NAME	FUNCTION
1	CB12	Digital Control Input for Analog Switches 1 and 2. Drive CB12 low to connect COM1 to NC1 and COM2 to NC2. Drive CB12 high to connect COM1 to NO1 and COM2 to NO2.
2	CB34	Digital Control Input for Analog Switches 3 and 4. Drive CB34 low to connect COM3 to NC3 and COM4 to NC4. Drive CB34 high to connect COM3 to NO3 and COM4 to NO4.
3	CB56	Digital Control Input for Analog Switches 5 and 6. Drive CB56 low to connect COM5 to NC5 and COM6 to NC6. Drive CB56 high to connect COM5 to NO5 and COM6 to NO6.
4	COM4	Analog Switch 4—Common Terminal
5	COM5	Analog Switch 5—Common Terminal
6	COM6	Analog Switch 6—Common Terminal
7	NC6	Analog Switch 6—Normally Closed Terminal
8	NC5	Analog Switch 5—Normally Closed Terminal
9	NC4	Analog Switch 4—Normally Closed Terminal
10	NC3	Analog Switch 3—Normally Closed Terminal
11	NC2	Analog Switch 2—Normally Closed Terminal
12	NC1	Analog Switch 1—Normally Closed Terminal
13	GND	Ground
14	V _{CC}	Positive Supply Voltage. Bypass V _{CC} to GND with a 0.1µF ceramic capacitor as close as possible to the device.
15	EN, $\overline{\text{EN}}$	Enable Logic Input. For the MAX4996, drive EN high to enable all the switches. Drive EN low to disable all switches. For the MAX4996L, drive $\overline{\text{EN}}$ low to enable all the switches. Drive $\overline{\text{EN}}$ high to disable all switches. COM_ is high impedance when the switch is disabled. (See <i>Pin Configuration/Truth Tables</i> .)
16	COM3	Analog Switch 3—Common Terminal
17	COM2	Analog Switch 2—Common Terminal
18	COM1	Analog Switch 1—Common Terminal
19	NO1	Analog Switch 1—Normally Open Terminal
20	NO2	Analog Switch 2—Normally Open Terminal
21	NO3	Analog Switch 3—Normally Open Terminal
22	NO4	Analog Switch 4—Normally Open Terminal
23	NO5	Analog Switch 5—Normally Open Terminal
24	NO6	Analog Switch 6—Normally Open Terminal
—	EP	Exposed Paddle. Internally connected to GND. Connect to a large ground plane to maximize thermal performance; not intended as an electrical connection point.

Triple DPDT, Low-Capacitance Data Switches

Timing Circuits/Timing Diagrams

MAX4996/MAX4996L

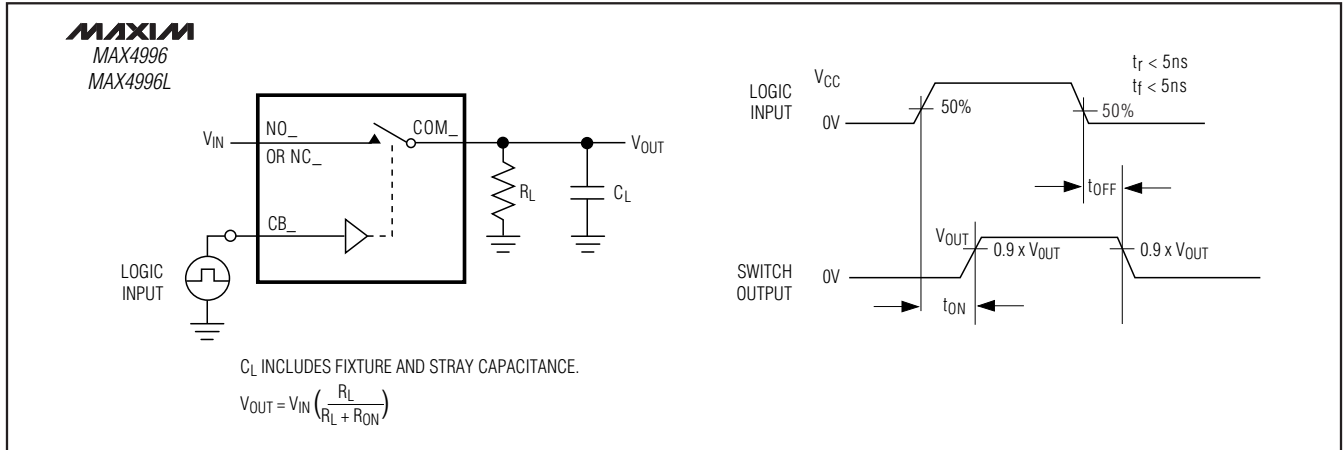

Figure 1. Switching Time

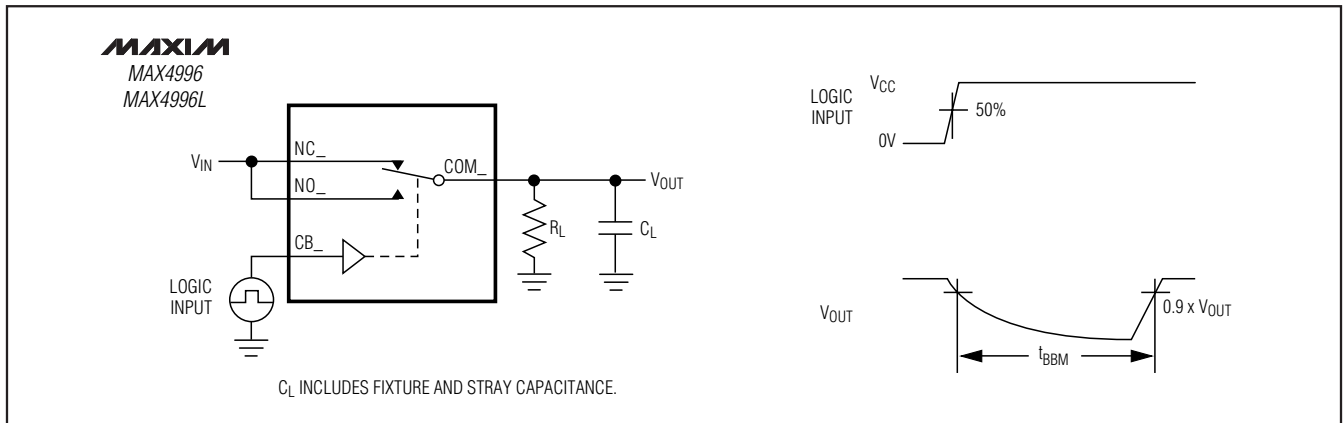

Figure 2. Break-Before-Make Interval

Triple DPDT, Low-Capacitance Data Switches

Timing Circuits/Timing Diagrams (continued)

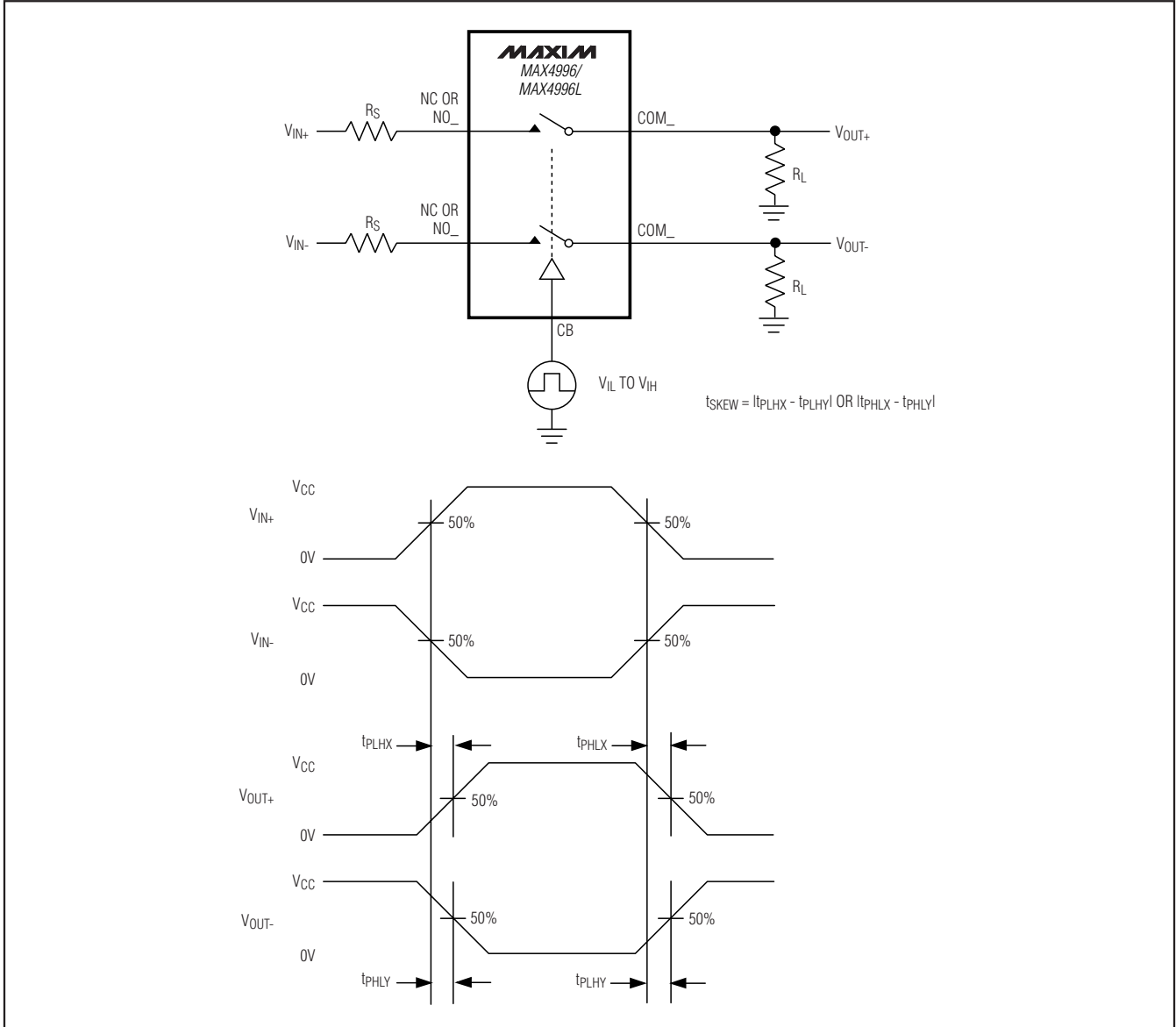

Figure 3. Input/Output Skew Timing Diagram

Triple DPDT, Low-Capacitance Data Switches

MAX4996/MAX4996L

Timing Circuits/Timing Diagrams (continued)

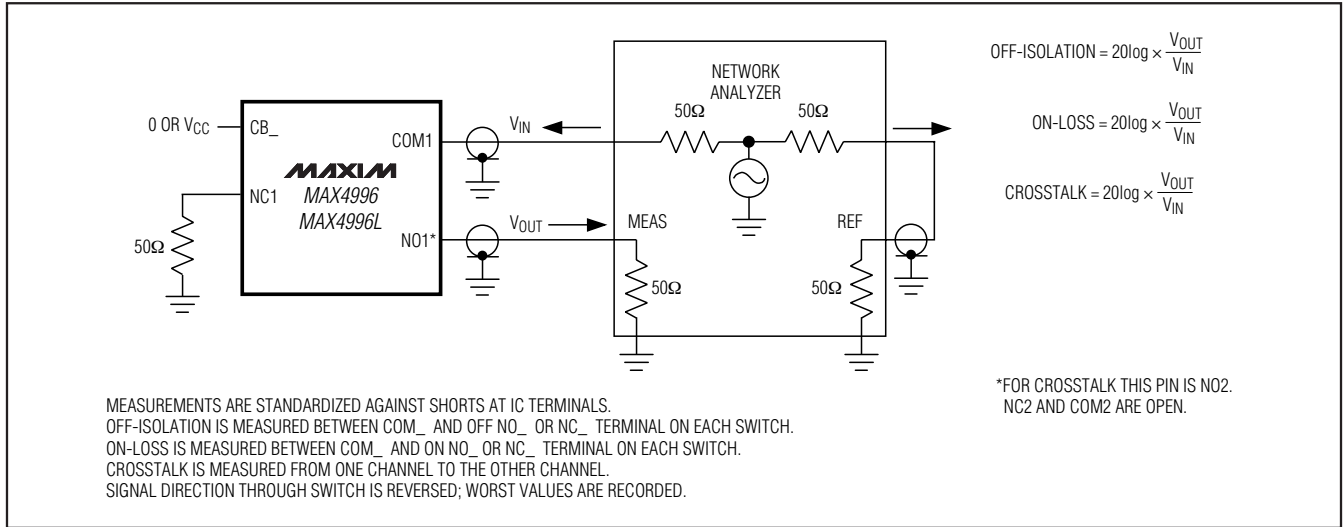

Figure 4. On-Loss, Off-Isolation, and Crosstalk

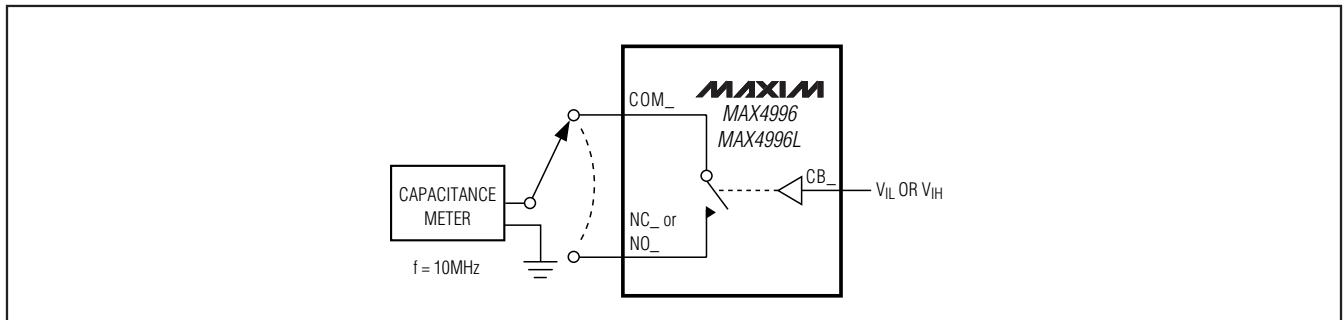

Figure 5. Channel On-/Off-Capacitance

Triple DPDT, Low-Capacitance Data Switches

Detailed Description

The MAX4996/MAX4996L triple DPDT analog switches operate from a single +2.5V to +5.5V supply and feature 2.0Ω (typ) on-resistance, low 6pF (typ) on-capacitance, and low power-supply current consumption. The combination of low resistance and low capacitance make this switch ideal for high-frequency applications.

The MAX4996 has an active-high enable input (EN) to disable the switches, while the MAX4996L has an active-low enable input (\overline{EN}) to disable the switches. The enable input decreases the supply current and also places the COM_ outputs in a high-impedance state.

Digital Control Inputs

Each pair of switches feature a digital-control logic input: CB_. CB_ controls the position of the switches as shown in the *Pin Configuration/Truth Tables*. The MAX4996/MAX4996L also feature an enable input to turn all switches on or off. Drive EN low on the MAX4996, or \overline{EN} high on the MAX4996L, to disable the switches. While disabled, the switches are high-impedance and the supply current drops to 0.1μA (typ). To enable all switches, drive EN high on the MAX4996 or \overline{EN} low on the MAX4996L.

Driving all digital inputs (CB_, EN, \overline{EN}) rail-to-rail minimizes supply current.

Analog Signal Levels

The on-resistance of the MAX4996/MAX4996L are very low and stable as the analog input signals are swept from ground to V_{CC} (see the *Typical Operating Characteristics*). These switches are bidirectional, allowing NO_, NC_, and COM_ to be configured as either inputs or outputs.

Applications Information

Power-Supply Bypassing

Power-supply bypassing improves noise margin and prevents switching noise from propagating from the V_{CC} supply to other components. A 0.1μF ceramic capacitor connected from V_{CC} to GND is adequate for most applications.

Power-Supply Sequencing

Always apply V_{CC} before the analog signals.

Functional Diagram

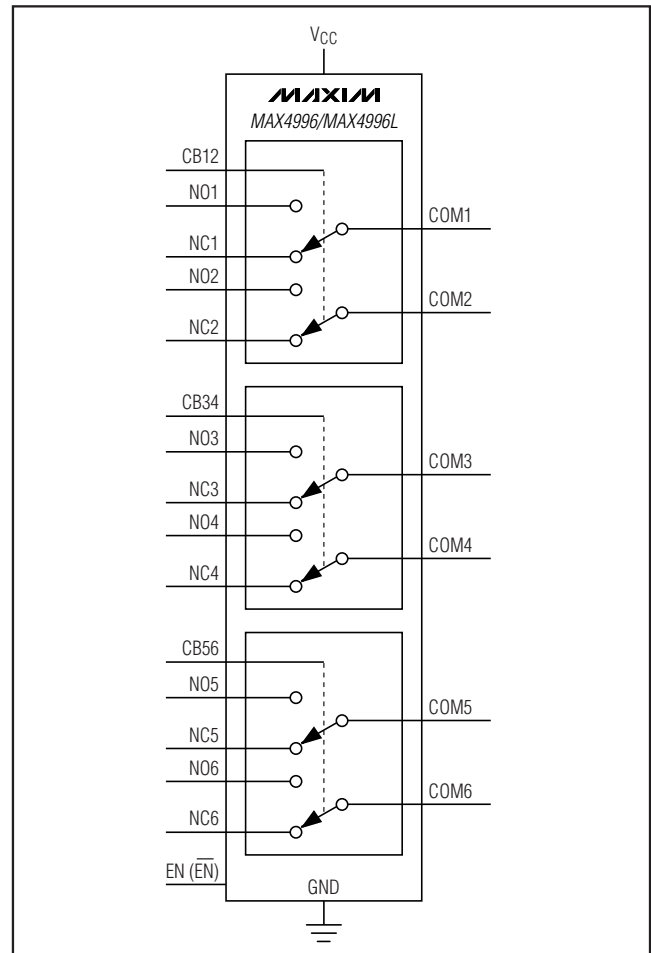

Chip Information

PROCESS: BiCMOS

Triple DPDT, Low-Capacitance Data Switches

Typical Operating Circuit

MAX4996/MAX4996L

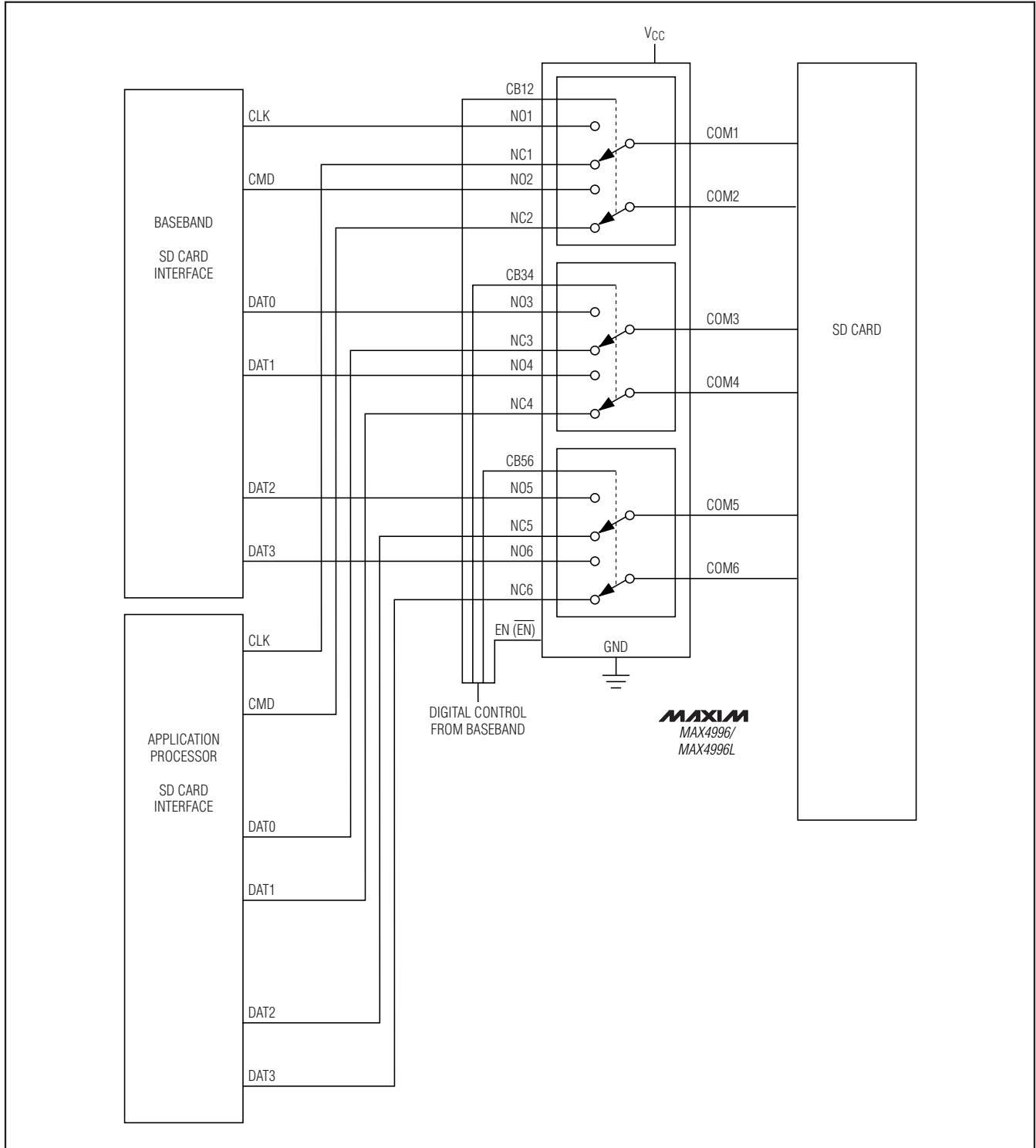

Triple DPDT, Low-Capacitance Data Switches

Package Information

(The package drawing(s) in this data sheet may not reflect the most current specifications. For the latest package outline information go to www.maxim-ic.com/packages.)

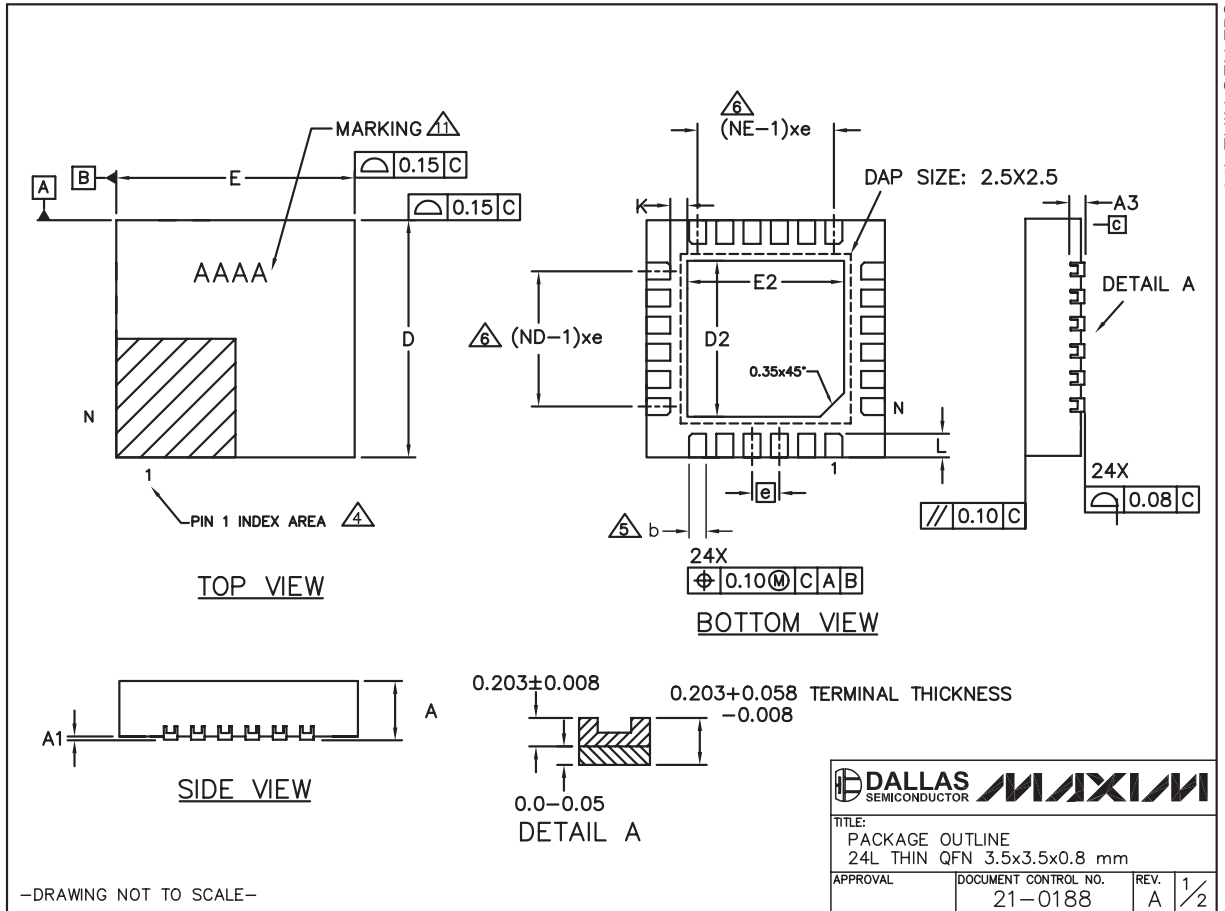

Triple DPDT, Low-Capacitance Data Switches

Package Information (continued)

(The package drawing(s) in this data sheet may not reflect the most current specifications. For the latest package outline information go to www.maxim-ic.com/packages.)

MAX4996/MAX4996L

NOTES:

1. DIMENSIONING & TOLERANCING CONFORM TO ASME Y14.5M-1994.
2. ALL DIMENSIONS ARE IN MILLIMETERS. ANGLES ARE IN DEGREES.
3. N IS THE TOTAL NUMBER OF TERMINALS.
4. THE TERMINAL #1 IDENTIFIER AND TERMINAL NUMBERING CONVENTION SHALL CONFORM TO JESD 95-1 SPP-012. DETAILS OF TERMINAL #1 IDENTIFIER ARE OPTIONAL, BUT MUST BE LOCATED WITHIN THE ZONE INDICATED. THE TERMINAL #1 IDENTIFIER MAY BE EITHER A MOLD OR MARKED FEATURE.
5. DIMENSION b APPLIES TO METALLIZED TERMINAL AND IS MEASURED BETWEEN 0.25mm AND 0.30mm FROM TERMINAL TIP.
6. ND AND NE REFER TO THE NUMBER OF TERMINALS ON EACH D AND E SIDE RESPECTIVELY.
7. DEPOPULATION IS POSSIBLE IN A SYMMETRICAL FASHION.
8. COPLANARITY APPLIES TO THE EXPOSED HEAT SINK SLUG AS WELL AS THE TERMINALS.
9. REFER TO JEDEC MO-220 EXCEPT D2, E2, & L DIMENSIONS.
10. WARPAGE SHALL NOT EXCEED 0.10mm.
11. MARKING IS FOR PACKAGE ORIENTATION PURPOSE ONLY.

COMMON DIMENSION				NOTES
REF.	MIN.	NOM.	MAX.	
A	0.70	0.75	0.80	
A1	0	-	0.05	
A3	0.20 REF			
b	0.15	0.20	0.25	
D	3.40	3.50	3.60	
E	3.40	3.50	3.60	
e	0.40 BSC.			
K	0.25	-	-	
L	0.30	0.35	0.40	
N	24			
ND	6			
NE	6			

	D2			E2		
	MIN.	NOM.	MAX.	MIN.	NOM.	MAX.
T243A3-1	2.20	2.30	2.40	2.20	2.30	2.40

-DRAWING NOT TO SCALE-

TITLE: PACKAGE OUTLINE 24L THIN QFN 3.5x3.5x0.8 mm	
APPROVAL	DOCUMENT CONTROL NO. 21-0188
REV. A	2/2

Maxim cannot assume responsibility for use of any circuitry other than circuitry entirely embodied in a Maxim product. No circuit patent licenses are implied. Maxim reserves the right to change the circuitry and specifications without notice at any time.

Maxim Integrated Products, 120 San Gabriel Drive, Sunnyvale, CA 94086 408-737-7600 13



Компания «ЭлектроПласт» предлагает заключение долгосрочных отношений при поставках импортных электронных компонентов на взаимовыгодных условиях!

Наши преимущества:

- Оперативные поставки широкого спектра электронных компонентов отечественного и импортного производства напрямую от производителей и с крупнейших мировых складов;
- Поставка более 17-ти миллионов наименований электронных компонентов;
- Поставка сложных, дефицитных, либо снятых с производства позиций;
- Оперативные сроки поставки под заказ (от 5 рабочих дней);
- Экспресс доставка в любую точку России;
- Техническая поддержка проекта, помощь в подборе аналогов, поставка прототипов;
- Система менеджмента качества сертифицирована по Международному стандарту ISO 9001;
- Лицензия ФСБ на осуществление работ с использованием сведений, составляющих государственную тайну;
- Поставка специализированных компонентов (Xilinx, Altera, Analog Devices, Intersil, Interpoint, Microsemi, Aeroflex, Peregrine, Syfer, Eurofarad, Texas Instrument, Miteq, Cobham, E2V, MA-COM, Hittite, Mini-Circuits, General Dynamics и др.);

Помимо этого, одним из направлений компании «ЭлектроПласт» является направление «Источники питания». Мы предлагаем Вам помощь Конструкторского отдела:

- Подбор оптимального решения, техническое обоснование при выборе компонента;
- Подбор аналогов;
- Консультации по применению компонента;
- Поставка образцов и прототипов;
- Техническая поддержка проекта;
- Защита от снятия компонента с производства.



Как с нами связаться

Телефон: 8 (812) 309 58 32 (многоканальный)

Факс: 8 (812) 320-02-42

Электронная почта: org@eplast1.ru

Адрес: 198099, г. Санкт-Петербург, ул. Калинина, дом 2, корпус 4, литера А.