



Series 291

Precision, Long-life 12mm Optical Encoder

- Available with 4, 6, 8, 24,32, 64 Pulses per Revolution
- Optional Momentary Switch
- Multiple options for terminations, resolution, cable lengths, and operating voltage



Description

The 291 Series allows versatility in design applications by providing highly reliable, precise digital output and long rotational life with our non-contacting design. This product provides flexibility in resolution, power consumption, and operating temperatures. The options of Schmitt trigger, detents, momentary switch, shaft & bushing length, dual shaft, termination styles, torque, operating voltage, and IP ratings provide flexibility to meet your exacting design requirements.

Ordering Information

Series	Termination	Bushing Length	Shaft Length	Shaft Trim	Output Combination	Operating Voltage	Switch	Schmitt Trigger & Locating Lug
291	V1	0	22	F	832	A	B	A

Code	Termination
V1	.050" pitch pins Rear facing .132" length(not for 64 PPR)
P1	.10" pitch pins Rear facing .236" length
*C4	4" ribbon cable With .050" pitch connector terminals (not for 64 PPR)
*C5	5" ribbon cable With .050" pitch connector terminals (not for 64 PPR)
*C6	6" ribbon cable With .050" pitch connector terminals (not for 64 PPR)

Code	Shaft Length "L"
Single shaft structure	
22	.687"
24	.875"
Dual shaft structure	
DD	Outer shaft: .685" Inner shaft: 1.059" (Not available with locating lug, 32 and 64 PPR, see page 8 for additional details)

Code	Spec.
F	Flat
S	Slotted

Code	Spec.
A	None
B	Momentary (not for 64 P)

Code	Spec.
BLANK	Without Schmitt trigger, With locating lug (not for 32, 64 PPR)
A	Without Schmitt trigger, Without locating lug (not for 32, 64 PPR)
S	With Schmitt trigger, Without locating lug
B	With Schmitt trigger, With locating lug

Code	Spec.
A	5.0V
B	3.3V (not for 64 PPR)

Code	Output	Combination
832	8 PPR, 32 Detents	
624	6 PPR, 24 Detents	
416	4 PPR, 16 Detents	
800	8 PPR, No Detents	
600	6 PPR, No Detents	
400	4 PPR, No Detents	
X00	24 PPR, No Detents (only available with Schmitt trigger)	
X24	24 PPR, 24 Detents (only available with Schmitt trigger)	
Y00	32 PPR, No Detents (only available with Schmitt trigger)	
Z00	64 PPR, No Detents (only available with Schmitt trigger)	

Code	Bushing Length "B"
0	.312" For single shaft construction
D	.256" For dual shaft construction (not for 32, 64 PPR)

Note: * Cable connector for C4, C5, C6 is AMP P/N 215083-6 or Equivalent

Electrical Specifications

Encoder Function					
Parameter	Conditions & Remarks	Min	Nominal	Max	Unit
Voltage (4, 6, 8, 24, 32 PPR)		4.75	5.0	5.25	VDC
		3.175	3.3	3.425	
Voltage (64 PPR)		4.5	5.0	5.5	VDC
Output Code	2-Bit Quadrature Channel A leads Channel B by 90° during clockwise rotation				
Sink Current	5.0 VDC	2.0mA			
	3.3 VDC	1.0mA			
Power Consumption	5.0 VDC			150	mW
	3.3 VDC			80	mW
Resolution	4, 6, 8, 24, 32, 64				Pulses per Revolution

Mechanical and Environmental

Manual Soldering	Maximum temperature of 350°C for 5 seconds				
RoHS	Lead-Free. Fully compliant to RoHS Directive				
Shock :	Per MIL-STD-883F (100G's)				
Vibration :	Per MIL-STD-883F (15G's)				
IP Rating (4, 6, 8, 24, 32 PPR):	IP 50				
IP Rating (64 PPR):	IP 40				
Packaging :	Standard anti-static tray packaging				
Operating Temperature:	-40°C to +85°C				
Storage Temperature:	-55°C to +100°C				
Storage Temperature: (32, 64 PPR)	-40°C to +100°C				
Rotational Life	No detent @ 30 RPM	3 Million Cycles			
	With detent @ 30 RPM	1 Million Cycles			
Push-Pull Strength of Shaft (4,6,8,24, 32 PPR) (64 PPR)	10 seconds	20 kg			
	10 seconds	13.6 kg			
Terminal Pull-out Strength	10 seconds	6 kg			
Rotational Torque	(4, 6, 8, 24 PPR)	Running	10 to 30 gf-cm		
		(32 PPR)	Running	30 gf-cm Max.	
	(64 PPR)	Running	100 gf-cm Max.		
Rotational Torque	24 Detents	90 to 190 gf-cm			
	16, 32 Detents	50 to 150 gf-cm			
Detent Options	0, 16, 24, 32				

Optional Momentary Switch Function:

Parameter	Conditions & Remarks	Min.	Nominal	Max	Unit
Switch contact resistance				10	ohms
Switch rating	5 VDC @10 mA				
Switch travel		0.25	0.5	0.75	mm
Actuation Force		400	510	620	grams
Switch Life	Standard	1 Million			Actuations
Switch Life	Consult CTS for custom life requirements				

Mechanical Specifications

Figure 1 – 291V1... – Without Schmitt Trigger, With Left Locating Lug, .050” Pitch Pins Facing Rear

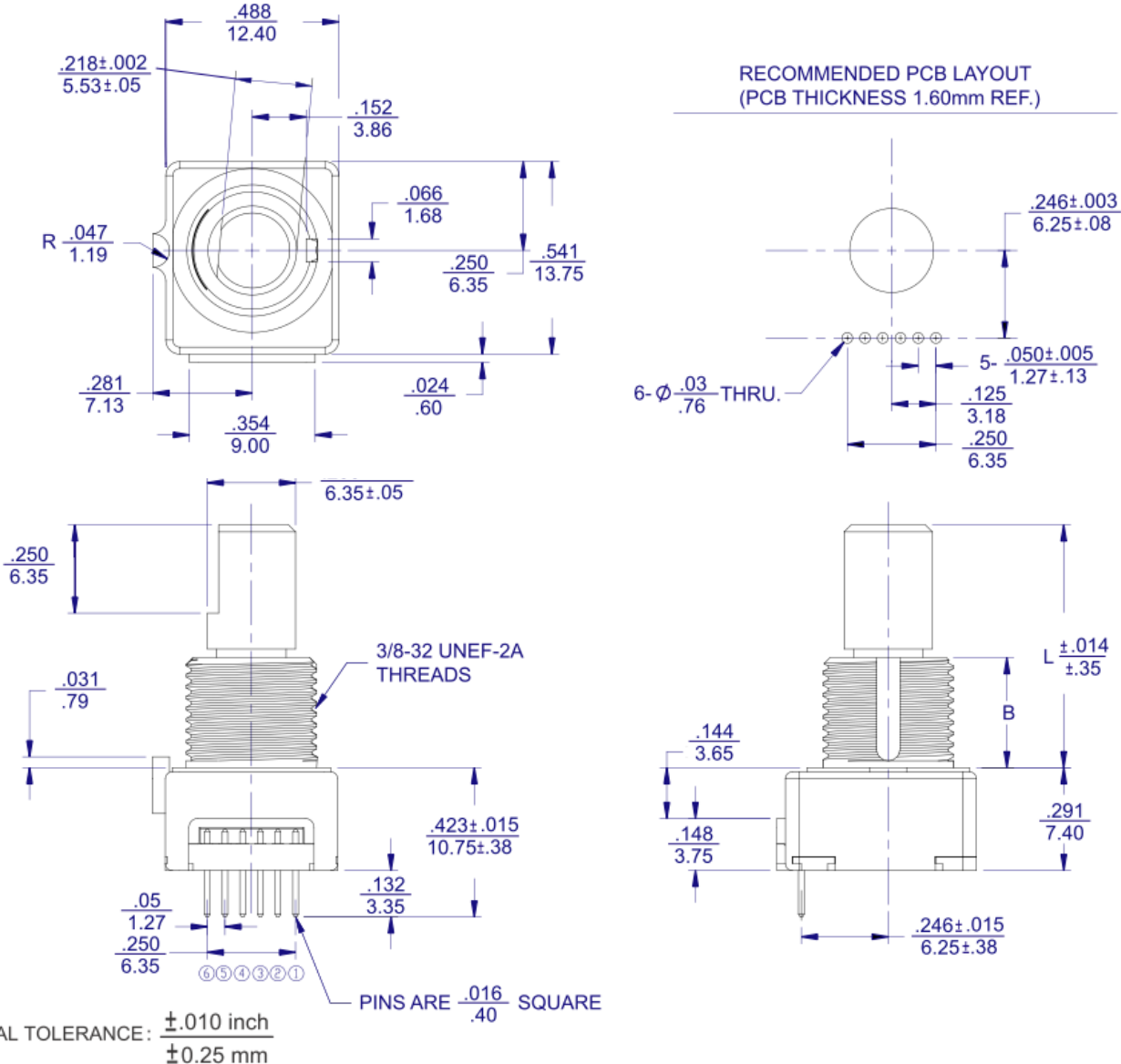
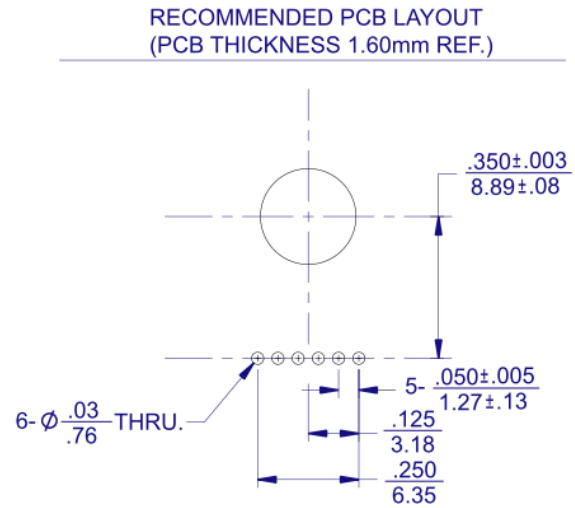

Figure 2 – 291V1...S – With Schmitt Trigger, Without Locating Lug, .050" Pitch Pins Facing Rear



GENERAL TOLERANCE: $\pm .010$ inch
 ± 0.25 mm

Figure 3 – 291V1...A – Without Schmitt Trigger, Without Locating Lug, .050" Pitch Pins Facing Rear



GENERAL TOLERANCE: $\pm .010$ inch
 ± 0.25 mm

Figure 4 – 291V1...B – With Schmitt Trigger, With Locating Lug, .050" Pitch Pins Facing Rear

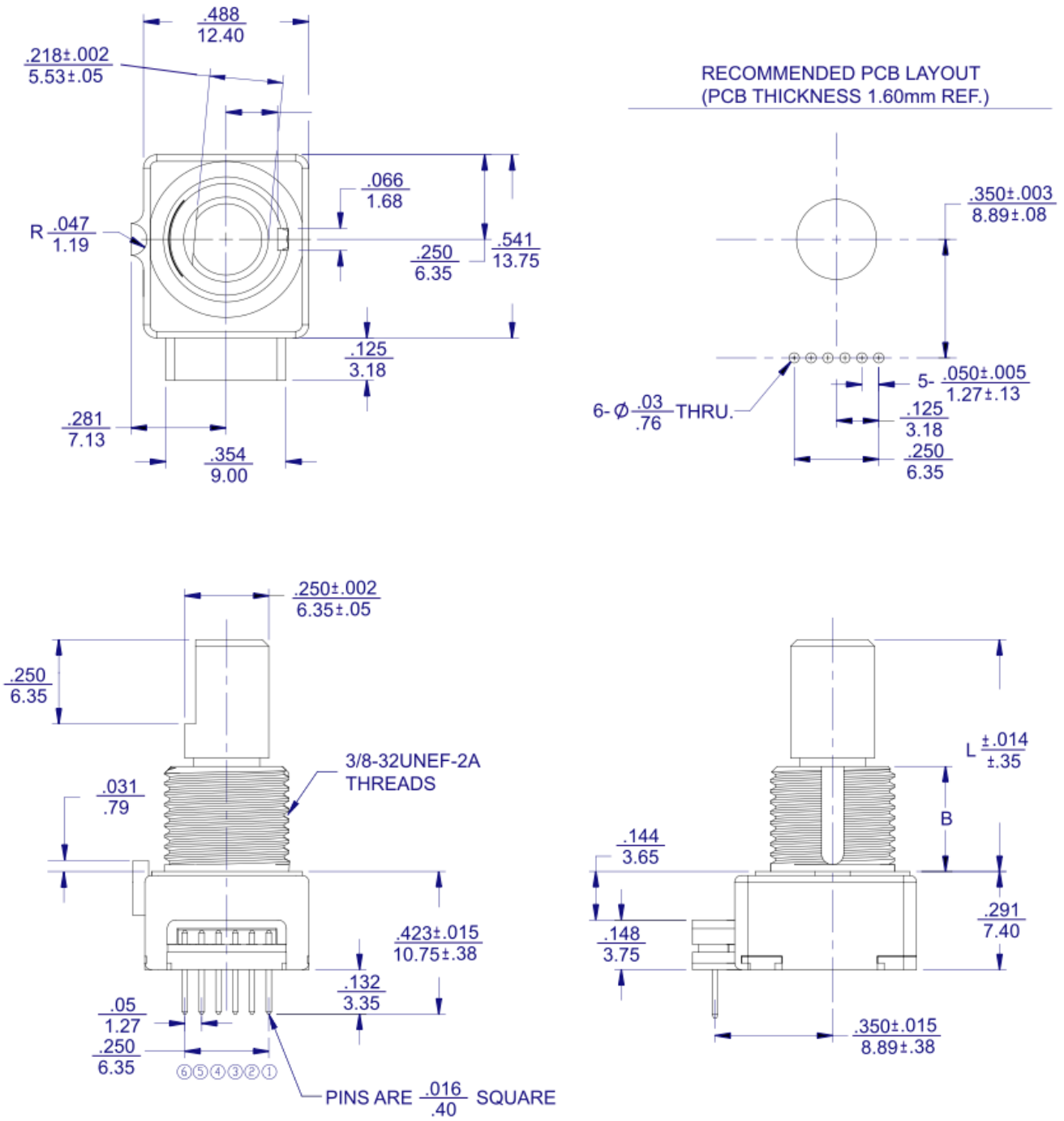

GENERAL TOLERANCE: $\pm .010$ inch
 ± 0.25 mm

Figure 5 – 291P1...A – Without Schmitt Trigger, Without Locating Lug, .100" Pitch Pins Facing Rear
291P1...S – With Schmitt Trigger, Without Locating Lug, .100" Pitch Pins Facing Rear



Figure 6 –291P1... – Without Schmitt Trigger, With Locating Lug, .100" Pitch Pins Facing Rear
291P1...B – With Schmitt Trigger, With Locating Lug, .100" Pitch Pins Facing Rear



GENERAL TOLERANCE: $\pm .010$ inch
 ± 0.25 mm

Figure 7 –291C... – Without Schmitt Trigger, With Locating Lug, With Ribbon Cable
291C...B – With Schmitt Trigger, With Locating Lug, With Ribbon Cable



GENERAL TOLERANCE: $\pm .010$ inch
 ± 0.25 mm

Figure 8 – 291C...A – Without Schmitt Trigger, Without Locating Lug, With Ribbon Cable
291C...S – With Schmitt Trigger, Without Locating Lug, With Ribbon Cable



Figure 9 – 291P1...Z00AA – 64 PPR, With Schmitt Trigger, With Locating Lug, .100" Pitch Pins Facing Rear, Without Momentary Switch

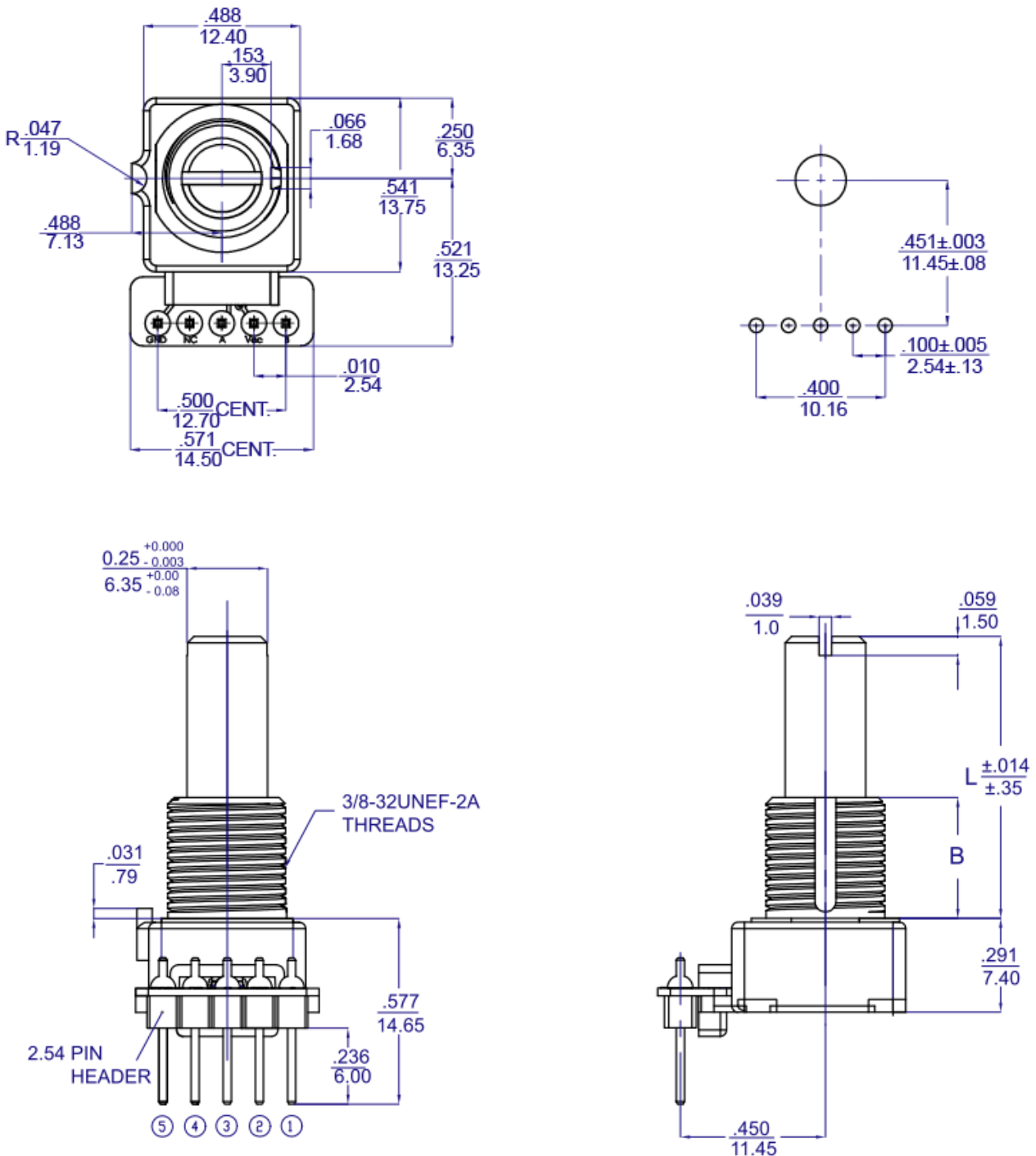

GENERAL TOLERANCE: $\pm .010$ inch $\frac{\text{inch}}{\text{mm}}$
 ± 0.25 mm

4, 6, 8, 24 PPR

**Electric Circuit And Waveform
(Without Schmitt Trigger Design)**

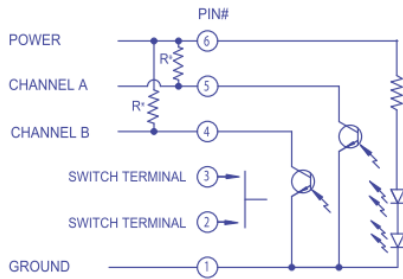

*Product will function properly with external 2.2KΩ pull up resistors.

Standard Quadrature 2-Bit Code

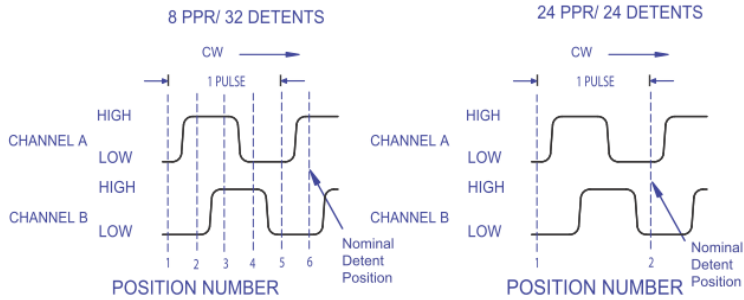

1. 8 PPR/32 detents is shown
2. Code repeats every 4 positions
3. Channel A Leads Channel B in CW direction and lags in CCW direction

1. 24 PPR/24 detents is shown
2. The nominal detent position is located when both Channel A and B are low
3. Channel A Leads Channel B in CW direction and lags in CCW direction

4, 6, 8, 24, 32 PPR

**Electric Circuit And Waveform
(With Schmitt Trigger Design)**

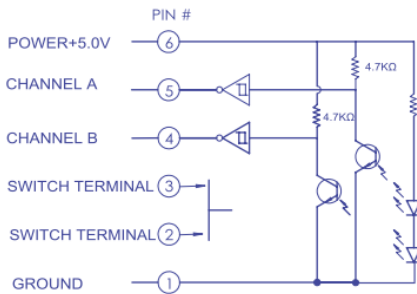

*Schmitt trigger and pull-up resistor (4.7KΩ) are integrated inside CTS optical encoder, so it's not necessary to have external pull-up resistors for application circuit.

Standard Quadrature 2-Bit Code

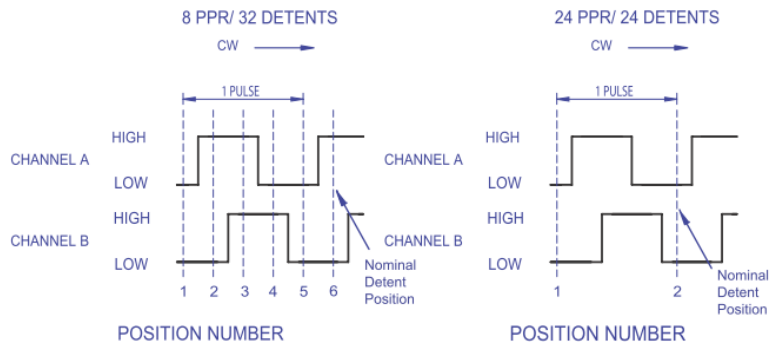

1. 8 PPR/32 detents is shown
2. Code repeats every 4 positions
3. Channel A Leads Channel B in CW direction and lags in CCW direction

1. 24 PPR/24 detents is shown
2. The nominal detent position is located when both Channel A and B are low
3. Channel A Leads Channel B in CW direction and lags in CCW direction

64 PPR

**Electric Circuit And Waveform
(With Schmitt Trigger Design)**

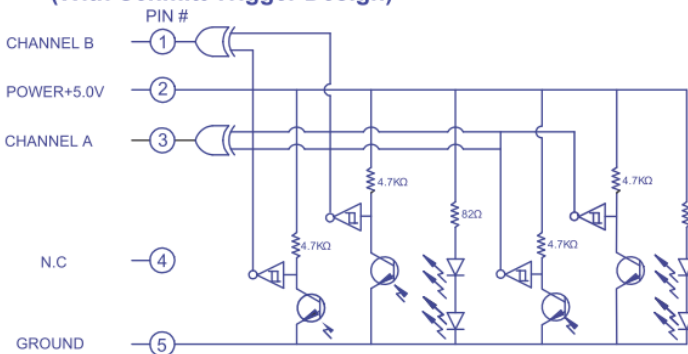

*Open collector with integrated XOR Gate, schmitt trigger and 4.7KΩ pull-up resistor are inside CTS optical encoder, so it's not necessary to have external pull-up resistors for application circuit.

Standard Quadrature 2-Bit Code

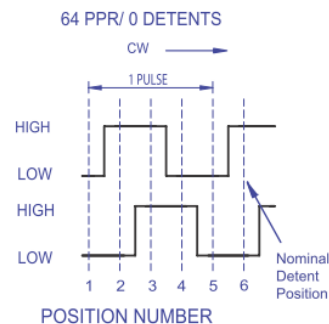

1. 64 PPR/0 detents is shown
2. Code repeats every 4 positions
3. Channel A Leads Channel B in CW direction and lags in CCW direction

Dual Shaft Construction



OUTER FLATTED SHAFT DIMENSION

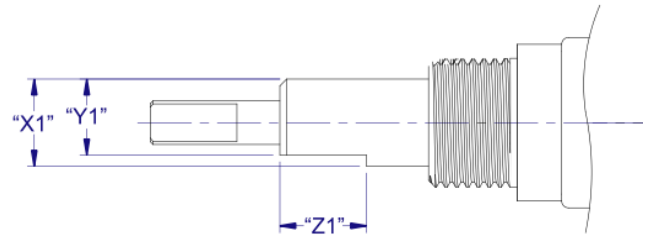

D - DUAL

	X	Y	Z	B
Imperial	.125"	.094"	.250"	.256"
Metric	3.18	2.40	6.35	6.50

Single Shaft Trim Options

FLATTED

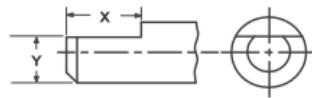

Shaft Trim	Diameter	X	Y
F	.250" (6.35 mm)	.250" (6.35 mm)	.218" (5.53 mm)

SD SLOT



Shaft Trim	Diameter	X	Y
S	.250" (6.35 mm)	.059" (1.5mm)	.039" (1.0mm)

Mouser Electronics

Authorized Distributor

Click to View Pricing, Inventory, Delivery & Lifecycle Information:

CTS:

[291C6022F624AB](#) [291C6022F832AB](#) [291V1022F624AB](#) [291V1022F832AB](#) [291P1024SZ00AAB](#)
[291P1022FX24ABB](#) [291P1022FY00ABB](#)



Компания «ЭлектроПласт» предлагает заключение долгосрочных отношений при поставках импортных электронных компонентов на взаимовыгодных условиях!

Наши преимущества:

- Оперативные поставки широкого спектра электронных компонентов отечественного и импортного производства напрямую от производителей и с крупнейших мировых складов;
- Поставка более 17-ти миллионов наименований электронных компонентов;
- Поставка сложных, дефицитных, либо снятых с производства позиций;
- Оперативные сроки поставки под заказ (от 5 рабочих дней);
- Экспресс доставка в любую точку России;
- Техническая поддержка проекта, помощь в подборе аналогов, поставка прототипов;
- Система менеджмента качества сертифицирована по Международному стандарту ISO 9001;
- Лицензия ФСБ на осуществление работ с использованием сведений, составляющих государственную тайну;
- Поставка специализированных компонентов (Xilinx, Altera, Analog Devices, Intersil, Interpoint, Microsemi, Aeroflex, Peregrine, Syfer, Eurofarad, Texas Instrument, Miteq, Cobham, E2V, MA-COM, Hittite, Mini-Circuits, General Dynamics и др.);

Помимо этого, одним из направлений компании «ЭлектроПласт» является направление «Источники питания». Мы предлагаем Вам помощь Конструкторского отдела:

- Подбор оптимального решения, техническое обоснование при выборе компонента;
- Подбор аналогов;
- Консультации по применению компонента;
- Поставка образцов и прототипов;
- Техническая поддержка проекта;
- Защита от снятия компонента с производства.



Как с нами связаться

Телефон: 8 (812) 309 58 32 (многоканальный)

Факс: 8 (812) 320-02-42

Электронная почта: org@eplast1.ru

Адрес: 198099, г. Санкт-Петербург, ул. Калинина, дом 2, корпус 4, литера А.