

MPL115A2

Miniature I²C digital barometer, 50 to 115 kPa

Rev. 10 — 10 October 2017

Data sheet: technical data

1 General description

The MPL115A2 is an absolute pressure sensor with a digital I²C output targeting low cost applications. A miniature 5 x 3 x 1.2 mm LGA package is ideally suited for the space constrained requirements of portable electronic devices. Low current consumptions of 5 μ A during Active mode and 1 μ A during Shutdown (Sleep) mode are essential when focusing on low-power applications. The wide operating temperature range spans from –40 °C to +105 °C to fit demanding environmental conditions.

The MPL115A2 employs a MEMS pressure sensor with a conditioning IC to provide accurate pressure measurements from 50 to 115 kPa. An integrated ADC converts pressure and temperature sensor readings to digitized outputs via a I²C port. Factory calibration data is stored internally in an on-board ROM. Utilizing the raw sensor output and calibration data, the host microcontroller executes a compensation algorithm to render *Compensated Absolute Pressure* with ± 1 kPa accuracy.

The MPL115A2 pressure sensor's small form factor, low power capability, precision, and digital output optimize it for barometric measurement applications.

2 Features

- Digitized pressure and temperature information together with programmed calibration coefficients for host micro use.
- Factory calibrated
- 50 kPa to 115 kPa absolute pressure
- ± 1 kPa accuracy
- 2.375 V to 5.5 V supply
- Integrated ADC
- I²C Interface (operates up to 400 kHz)
- 7-bit I²C address = 60h
- Monotonic pressure and temperature data outputs
- Surface mount RoHS compliant package

3 Applications

- Barometry (portable and desktop)
- Altimeters
- Weather stations
- Hard-disk drives (HDD)
- Industrial equipment
- Health monitoring
- Air control systems



4 Ordering information

Table 1. Ordering information

Type number	Package		Version
	Name	Description	
MPL115A2	TSON8	LGA 8 I/O, 3 X 5 X 1.25 PITCH, SENSOR 1.2MAX MM PKG	SOT1769-1

4.1 Ordering options

Table 2. Ordering options

Device Name	Package Options	# of Ports			Pressure Type			Digital Interface
		None	Single	Dual	Gauge	Differential	Absolute	
MPL115A2	Tray	•					•	I ² C
MPL115A2T1	Tape & Reel (1000)	•					•	I ² C

5 Block diagram

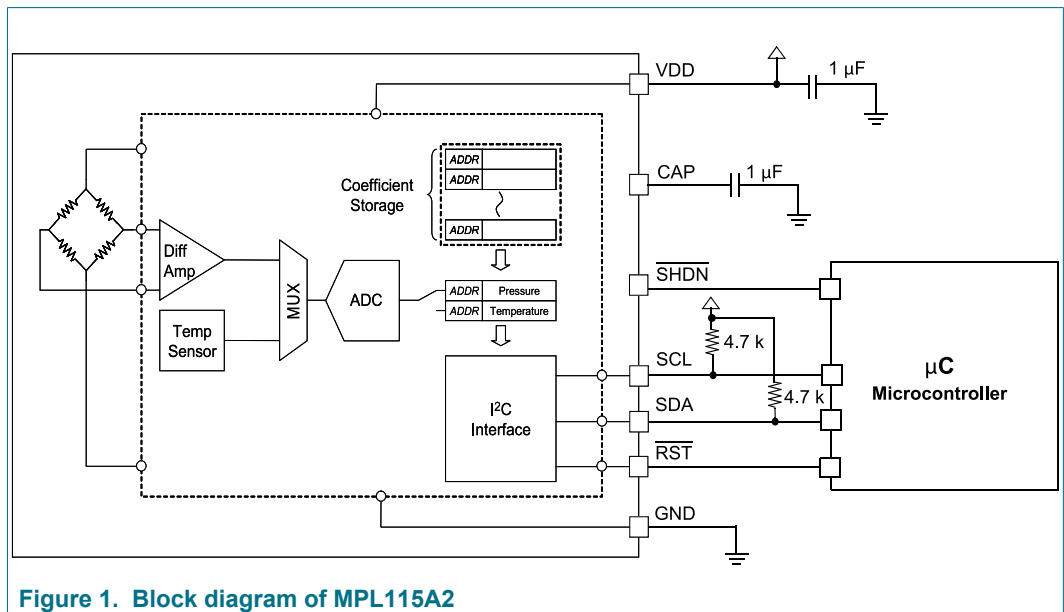
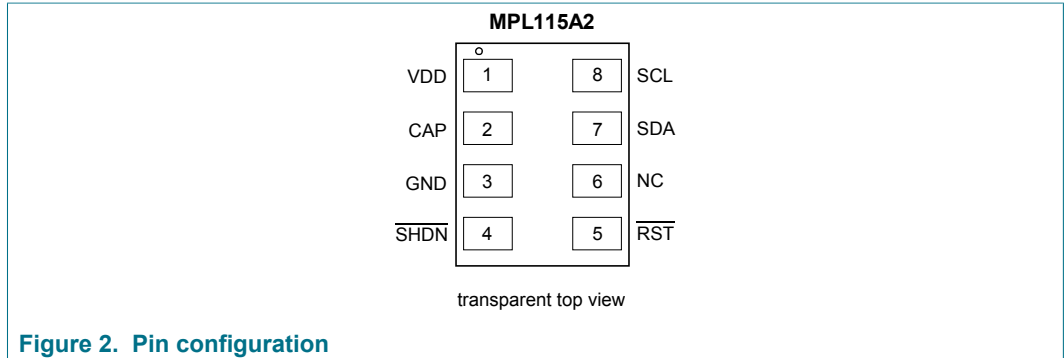

Figure 1. Block diagram of MPL115A2

6 Pinning information

6.1 Pinning



6.2 Pin description

Table 3. Pin description

Pin	Name	Function
1	VDD	Power Supply Connection: VDD range is 2.375 V to 5.5 V.
2	CAP	1 μF connected to ground.
3	GND	Ground
4	$\overline{\text{SHDN}}$	Shutdown: Connect to GND to disable the device. When in shutdown, the part draws no more than 1 μA supply current and all communications pins ($\overline{\text{RST}}$, SCL, SDA) are high impedance. Connect to VDD for normal operation.
5	RST	Reset: Connect to ground to disable I ² C communications.
6	NC	No connection
7	SDA ^[1]	Serial data I/O line
8	SCL ^[1]	Serial clock input.

[1] Use 4.7 k Ω pullup resistors for I²C communication.

7 Handling and Board Mount Recommendations

The sensor die is sensitive to light exposure. Direct light exposure through the port hole can lead to varied accuracy of pressure measurement. Avoid such exposure to the port during normal operation.

7.1 Methods of Handling

Components can be picked from the carrier tape using either the vacuum assist or the mechanical type pickup heads. A vacuum assist nozzle type is most common due to its lower cost of maintenance and ease of operation. The recommended vacuum nozzle configuration should be designed to make contact with the device directly on the metal cover and avoid vacuum port location directly over the vent hole in the metal cover of the

device. Multiple vacuum ports within the nozzle may be required to effectively handle the device and prevent shifting during movement to placement position.

Vacuum pressure required to adequately support the component should be approximately 25 inches Hg (85 kPa). This level is typical of in-house vacuum supply. Pickup nozzles are available in various sizes and configurations to suit a variety of component geometries. To select the nozzle best suited for the specific application, it is recommended that the customer consult their pick and place equipment supplier to determine the correct nozzle. In some cases it may be necessary to fabricate a special nozzle depending on the equipment and speed of operation.

Tweezers or other mechanical forms of handling that have a sharp point are not recommended since they can inadvertently be inserted into the vent hole of the device. This can lead to a puncture of the MEMS element that will render the device inoperable.

7.2 Board Mount Recommendations

Components can be mounted using solder paste stencil, screen printed or dispensed onto the PCB pads prior to placement of the component. The volume of solder paste applied to the PCB is normally sufficient to secure the component during transport to the subsequent reflow soldering process. Use of adhesives to secure the component is not recommended, but where necessary can be applied to the underside of the device.

Solder pastes are available in variety of metal compositions, particle size and flux types. The solder paste consists of metals and flux required for a reliable connection between the component lead and the PCB pad. Flux aids the removal of oxides that may be present on PCB pads and prevents further oxidation from occurring during the solder process.

The use of a No-Clean (NC) flux is recommended for exposed cavity components. Using pressure spray, wire brush, or other methods of cleaning is not recommended since it can puncture the MEMS device and render it unusable. If cleaning of the pcb is performed, Water Soluble (WS) flux can be used. However, it is recommended the component cavity is protected by adhesive Kapton tape, vinyl cap or other means prior to the cleaning process. This covering will prevent damage to the MEMS device, contamination, and foreign materials from being introduced into device cavity as result of cleaning processes.

Ultrasonic cleaning is not recommended as the frequencies can damage wire bond interconnections and the MEMS device.

8 Functional description

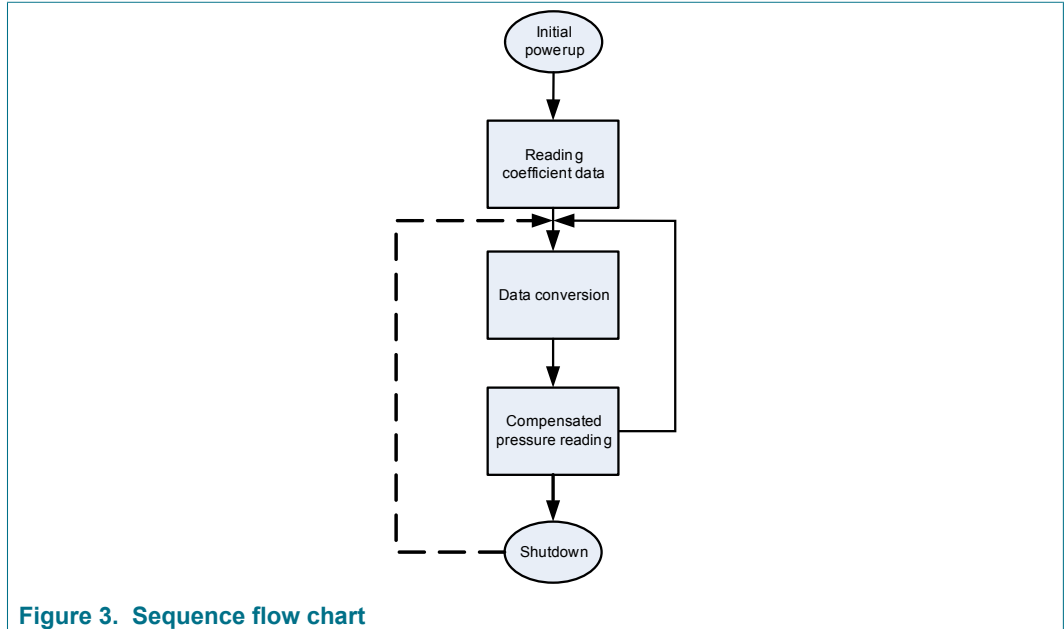

Figure 3. Sequence flow chart

The MPL115A interfaces to a host (or system) microcontroller in the user’s application. All communications are via I²C. A typical usage sequence is as follows:

Initial power-up

All circuit elements are active. I²C port pins are high impedance and associated registers are cleared. The device then enters standby mode.

Reading coefficient data

The user then typically accesses the part and reads the coefficient data. The main circuits within the slave device are disabled during read activity. The coefficients are usually stored in the host microcontroller local memory but can be re-read at any time.

It is not necessary to read the values stored in the host microcontroller multiple times because the coefficients within a device are constant and do not change. However, note that the coefficients will be different from device to device, and cannot be used for another part.

Data conversion

This is the first step that is performed each time a new pressure reading is required which is initiated by the host sending the CONVERT command. The main system circuits are activated (wake) in response to the command and after the conversion completes, the result is placed into the Pressure and Temperature ADC output registers.

The conversion completes within the maximum conversion time, t_c (see row 7, in Table 10). The device then enters standby mode.

Compensated pressure reading

After the conversion has been given sufficient time to complete, the host microcontroller reads the result from the ADC output registers and calculates the Compensated Pressure, a barometric/atmospheric pressure value which is compensated for changes in temperature and pressure sensor linearity. This is done using the coefficient data from the MPL115A and the raw sampled pressure and temperature ADC output values, in a compensation equation (detailed later). Note that this is an absolute pressure measurement with a vacuum as a reference.

From this step the host controller may either wait and then return to the Data Conversion step to obtain the next pressure reading or it may go to the Shutdown step.

Shutdown

For longer periods of inactivity the user may assert the $\overline{\text{SHDN}}$ input by driving this pin low to reduce system power consumption. This removes power from all internal circuits, including any registers. In the shutdown state, the Pressure and Temperature registers will be reset, losing any previous ADC output values.

This step is exited by taking the $\overline{\text{SHDN}}$ pin high. Wait for the maximum wakeup time, t_w (see row 8, in Table 10), after which another pressure reading can be taken by transitioning to the data Conversion step.

Table 4. Device memory map

Address	Name	Description
00h	Padc_MSB	10-bit Pressure ADC output value MSB
01h	Padc_LSB	10-bit Pressure ADC output value LSB
02h	Tadc_MSB	10-bit Temperature ADC output value MSB
03h	Tadc_LSB	10-bit Temperature ADC output value LSB
04h	a0_MSB	a0 coefficient MSB
05h	a0_LSB	a0 coefficient LSB
06h	b1_MSB	b1 coefficient MSB
07h	b1_LSB	b1 coefficient LSB
08h	b2_MSB	b2 coefficient MSB
09h	b2_LSB	b2 coefficient LSB
0Ah	c12_MSB	c12 coefficient MSB
0Bh	c12_LSB	c12 coefficient LSB
0Ch	reserved ^[1]	—
0Dh	reserved ^[1]	—
0Eh	reserved ^[1]	—
0Fh	reserved ^[1]	—

Address	Name	Description
10h	reserved	—
11h	reserved	—
12h	CONVERT	Start Pressure and Temperature Conversion

[1] This register is set to 00h. It is reserved, and was previously utilized as Coefficient values, c11 and c22, which were always 00h.

For values with less than 16 bits, the lower LSBs are zero. For example, c12 is 14 bits and is stored into 2 bytes as follows:

$$c12 \text{ MS byte} = c12[13:6] = [c12_{b13}, c12_{b12}, c12_{b11}, c12_{b10}, c12_{b9}, c12_{b8}, c12_{b7}, c12_{b6}]$$

$$c12 \text{ LS byte} = c12[5:0] \& \text{"00"} = [c12_{b5}, c12_{b4}, c12_{b3}, c12_{b2}, c12_{b1}, c12_{b0}, 0, 0]$$

8.1 Pressure, temperature and coefficient bit-width specifications

The table below specifies the initial coefficient bit-width specifications for the compensation algorithm and the specifications for Pressure and Temperature ADC values.

Table 5. Pressure, temperature and compensation coefficient specifications

	a0	b1	b2	c12	Padc	Tadc
Total Bits	16	16	16	14	10	10
Sign Bits	1	1	1	1	0	0
Integer Bits	12	2	1	0	10	10
Fractional Bits	3	13	14	13	0	0
dec pt zero pad	0	0	0	9	0	0

Example Binary Format Definitions:

a0 Signed, Integer Bits = 12, Fractional Bits = 3 :	Coeff a0 = S I ₁₁ I ₁₀ I ₉ I ₈ I ₇ I ₆ I ₅ I ₄ I ₃ I ₂ I ₁ I ₀ . F ₂ F ₁ F ₀
b1 Signed, Integer Bits = 2, Fractional Bits = 13 :	Coeff b1 = S I ₁ I ₀ . F ₁₂ F ₁₁ F ₁₀ F ₉ F ₈ F ₇ F ₆ F ₅ F ₄ F ₃ F ₂ F ₁ F ₀
b2 Signed, Integer Bits = 1, Fractional Bits = 14 :	Coeff b2 = S I ₀ . F ₁₃ F ₁₂ F ₁₁ F ₁₀ F ₉ F ₈ F ₇ F ₆ F ₅ F ₄ F ₃ F ₂ F ₁ F ₀
c12 Signed, Integer Bits = 0, Fractional Bits = 13, dec pt zero pad = 9 :	Coeff c12 = S 0 . 000 000 000 F ₁₂ F ₁₁ F ₁₀ F ₉ F ₈ F ₇ F ₆ F ₅ F ₄ F ₃ F ₂ F ₁ F ₀
Padc Unsigned, Integer Bits = 10 :	Padc U = I ₉ I ₈ I ₇ I ₆ I ₅ I ₄ I ₃ I ₂ I ₁ I ₀
Tadc Unsigned, Integer Bits = 10 :	Tadc U = I ₉ I ₈ I ₇ I ₆ I ₅ I ₄ I ₃ I ₂ I ₁ I ₀

Note: Negative coefficients are coded in 2's complement notation.

8.2 Compensation

The 10-bit compensated pressure output, Pcomp, is calculated as follows:

$$P_{comp} = a_0 + (b_1 + c_{12} \cdot T_{adc}) \cdot P_{adc} + b_2 \cdot T_{adc} \tag{1}$$

Where:

- P_{adc} is the 10-bit pressure ADC output of the MPL115A
- T_{adc} is the 10-bit temperature ADC output of the MPL115A
- a₀ is the pressure offset coefficient
- b₁ is the pressure sensitivity coefficient
- b₂ is the temperature coefficient of offset (TCO)
- c₁₂ is the temperature coefficient of sensitivity (TCS)

P_{comp} will produce a value of 0 with an input pressure of 50 kPa and will produce a full-scale value of 1023 with an input pressure of 115 kPa.

$$\text{Pressure (kPa)} = P_{comp} \cdot \left[\frac{115-50}{1023} \right] + 50 \tag{2}$$

8.3 Evaluation sequence, arithmetic circuits

The following is an example of the calculation for P_{comp}, the compensated pressure output. Input values are in **bold**.

$$\begin{aligned} c_{12}x_2 &= \mathbf{c_{12}} \cdot \mathbf{T_{adc}} \\ a_1 &= \mathbf{b_1} + c_{12}x_2 \\ a_1x_1 &= a_1 \cdot \mathbf{P_{adc}} \\ y_1 &= \mathbf{a_0} + a_1x_1 \\ a_2x_2 &= \mathbf{b_2} \cdot \mathbf{T_{adc}} \\ P_{comp} &= y_1 + a_2x_2 \end{aligned}$$

This can be calculated as a succession of Multiply Accumulates (MACs) operations of the form $y = a + b \cdot x$:

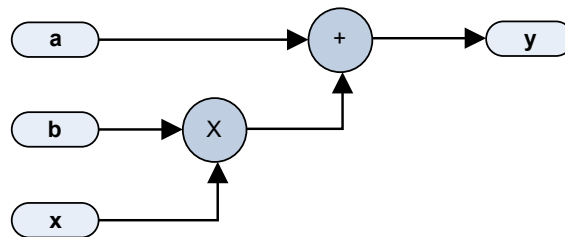

The polynomial can be evaluated ([Equation 1](#)) as a sequence of 3 MACs:

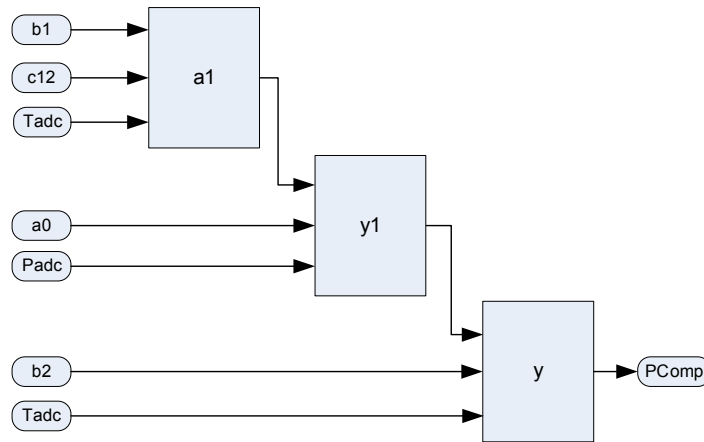

Please refer to NXP application note AN3785 for more detailed notes on implementation.

8.4 I²C device read/write operations

All device read/write operations are memory mapped. Device actions, for example, Start Conversions, are controlled by writing to the appropriate memory address location.

- For I²C the 7-bit device address (from Table 2) has a read/write toggle bit, where the least significant bit is '1' for read operations or '0' for write operations. The Device Address is C0h for a *Write* and the Device Address is C1h for a *Read*.
- The most significant bit in the Command tables below is not used and is don't care (X). In examples given it's set to '0'.

Refer to Sensor I²C Setup and FAQ Application Note AN4481 for more information on I²C communication between the sensor and host controller.

Table 6. I²C write commands

Legend: X - don't care

Command	Binary	HEX ^[1]
Devices Address + Write bit	1100 0000	C0h
Start Conversions	X001 0010	12h

[1] The command byte needs to be paired with a 00h as part of the I²C exchange to complete the passing of Start Conversions.

The actions taken by the part in response to each command are as follows:

Table 7. I²C write command description

Command	Action Taken
Start Conversions	Wake main circuits. Start clock. Allow supply stabilization time. Select pressure sensor input. Apply positive sensor excitation and perform A to D conversion. Select temperature input. Perform A to D conversion. Load the Pressure and Temperature registers with the result. Shut down main circuits and clock.

Table 8. I²C read command description

Legend: X - don't care

Command	Binary	HEX
Device Address + Read bit	1100 0001	C1h
Read Pressure MSB	X000 0000	00h
Read Pressure LSB	X000 0001	01h
Read Temperature MSB	X000 0010	02h
Read Temperature LSB	X000 0011	03h
Read Coefficient data byte 1	X000 0100	04h

These are MPL115A2 I²C commands to read coefficients, execute pressure and temperature conversions, and to read pressure and temperature data. The sequence of the commands for the interaction is given as an example to operate the MPL115A2.

Utilizing this gathered data, an example of the calculating the compensated pressure reading is given in floating point notation.

I²C commands (simplified for communication)

- Device Address + write bit "To Write" = C0h
- Device Address + read bit "To Read" = C1h
- Command to Write "Convert Pressure and Temperature" = 12h
- Command to Read "Pressure ADC High byte" = 00h
- Command to Read "Pressure ADC Low byte" = 01h
- Command to Read "Temperature ADC High byte" = 02h
- Command to Read "Temperature ADC Low byte" = 03h
- Command to Read "Coefficient data byte 1 High byte" = 04h

Read coefficients

[C0h], [04h], [C1h], [3Eh], [CEh], [B3h], [F9h], [C5h], [17h], [33h], [C8h]

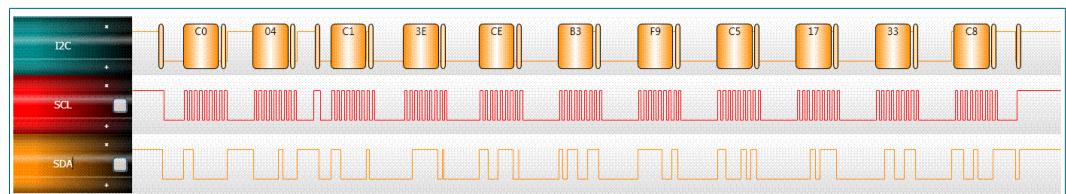
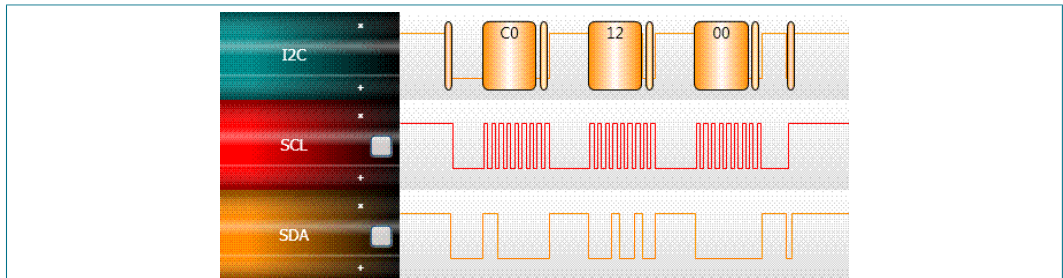

Figure 4. I²C read coefficient datagram

a0 coefficient MSB	=	3Eh			
a0 coefficient LSB	=	CEh	a0 coefficient	=	3ECEh = 2009.75
b1 coefficient MSB	=	B3h			
b1 coefficient LSB	=	F9h	b1 coefficient	=	B3F9h = -2.37585
b2 coefficient MSB	=	C5h			
b2 coefficient LSB	=	17h	b2 coefficient	=	C517h = -0.92047
c12 coefficient MSB	=	33h			
c12 coefficient LSB	=	C8h	c12 coefficient	=	33C8h = 0.000790



Command to I²C start conversion, 12h

Figure 5. I²C Start conversion datagram

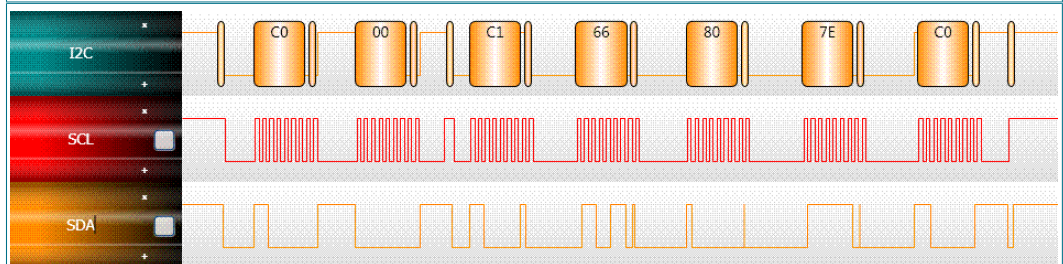

Figure 6. I²C read results datagram

Pressure MSB	=	66h			
Pressure LSB	=	80h	Pressure	=	6680h = 0110 0110 1100 0000
					= 410 ADC counts
Temperature MSB	=	7Eh			
Temperature LSB	=	C0h	Temperature	=	7EC0h = 0111 1110 1100 0000
					= 507 ADC counts

8.5 Example of pressure compensated calculation in floating-point notation

a0 coefficient = 2009.75
 b1 coefficient = -2.37585
 b2 coefficient = -0.92047
 c12 coefficient = 0.000790

Pressure = 410 ADC counts
 Temperature = 507 ADC counts

Pressure compensation

$$P_{comp} = a0 + (b1 + c12 \cdot T_{adc}) \cdot P_{adc} + b(c)$$

Using the evaluation sequence

The evaluation sequence is located in [Section 8.3](#).

c12x2 = c12 * Tadc = 0.000790 * 507 = 0.40053
 a1 = b1 + c12x2 = -2.37585 + 0.40053 = -1.97532
 a1x1 = a1 * Padc = -1.97532 * 410 = -809.8812
 y1 = a0 + a1x1 = 2009.75 + (-809.8812) = 1199.8688
 a2x2 = b2 * Tadc = -0.92047 * 507 = -466.67829
 PComp = y1 + a2x2 = 1199.8688 + (-466.67829) = 733.19051

$$\text{Pressure (kPa)} = P_{comp} \cdot \left[\frac{115-50}{1023} \right] + 50$$

$$= 96.59 \text{ kPa}$$

$$= 733.19 \cdot \left[\frac{115-50}{1023} \right] + 50$$

9 Maximum ratings

Table 9. Maximum ratings

Voltage (with respect to GND unless otherwise noted)

Symbol	Value	Units
V _{DD}	-0.3 to +5.5	V
$\overline{\text{SHDN}}$, RST, SDA, SCL	-0.3 to V _{DD} + 0.3	V
Operating Temperature Range	-40 to +105	°C
Storage Temperature Range	-40 to +125	°C
Overpressure	1000	kPa

10 Mechanical and electrical characteristics

Table 10. Mechanical and electrical characteristics

V_{DD} = 2.375 V to 5.5 V, T_A = -40 °C to +105 °C, unless otherwise noted. Typical values are at V_{DD} = 3.3 V, T_A = +25 °C.

Ref	Parameters	Symbol	Conditions	Min	Typ	Max	Units
1	Operating Supply Voltage	V _{DD}		2.375	3.3	5.5	V
2	Supply Current	I _{DD}	Shutdown ($\overline{\text{SHDN}}$ = GND)	—	—	1	μA
			Standby	—	3.5	10	μA
			Average – at one measurement per second	—	5	6	μA
Pressure Sensor							
3	Range			50	—	115	kPa
4	Resolution			—	0.15	—	kPa
5	Accuracy		-20 °C to 85 °C	—	—	±1	kPa
6	Power Supply Rejection		Typical operating circuit at DC		0.1	—	kPa/V
			100 mV p-p 217 Hz square wave plus 100 mV pseudo random noise with 10 MHz bandwidth		0.1	—	kPa
7	Conversion Time (Start Pressure and Temperature Conversion)	t _c	Time between start convert command and data available in the Pressure and Temperature registers	—	1.6	3	ms
8	Wakeup Time	t _w	Time between leaving Shutdown mode ($\overline{\text{SHDN}}$ goes high) and communicating with the device to issue a command or read data.	—	3	5	ms
I²C I/O Stages: SCL, SDA							
9	SCL Clock Frequency	f _{SCL}		—	—	400	kHz
10	Low Level Input Voltage	V _{IL}		—	—	0.3V _{DD}	V
11	High Level Input Voltage	V _{IH}		0.7V _{DD}	—	—	V

Ref	Parameters	Symbol	Conditions	Min	Typ	Max	Units
I²C Outputs: SDA							
12	Data Setup Time	t _{SU}	Setup time from command receipt to ready to transmit	0	—	0.4	s
I²C Addressing							
MPL115A2 uses 7-bit addressing, does not acknowledge the general call address 0000000. Slave address has been set to 60h or 1100000.							

11 Package outline

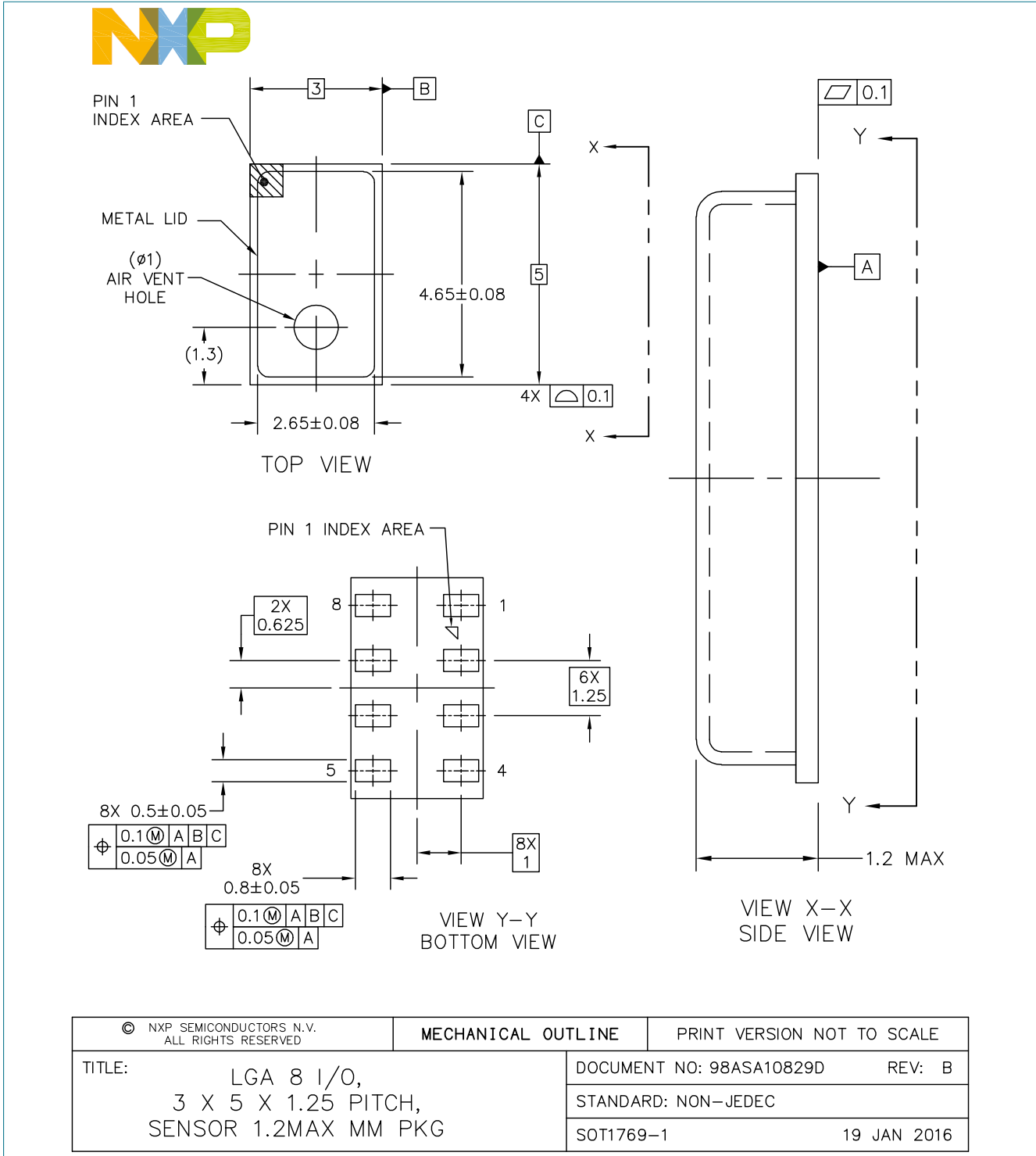



NOTES:

1. ALL DIMENSIONS IN MILLIMETERS.
2. DIMENSIONING AND TOLERANCING PER ASME Y14.5M-1994
3. STYLE:

PIN 1: VDD	PIN 5: CS
PIN 2: CAP	PIN 6: DOUT
PIN 3: GND	PIN 7: DIN
PIN 4: SHDN	PIN 8: SCLK

© NXP SEMICONDUCTORS N.V. ALL RIGHTS RESERVED	MECHANICAL OUTLINE	PRINT VERSION NOT TO SCALE
TITLE: LGA 8 I/O, 3 X 5 X 1.25 PITCH SENSOR 2.0MM PKG	DOCUMENT NO: 98ASA10829D STANDARD: NON-JEDEC SOT1769-1	REV: B 19 JAN 2016

Figure 7. Package outline SOT1769-1 (TSON8)

12 Packing information

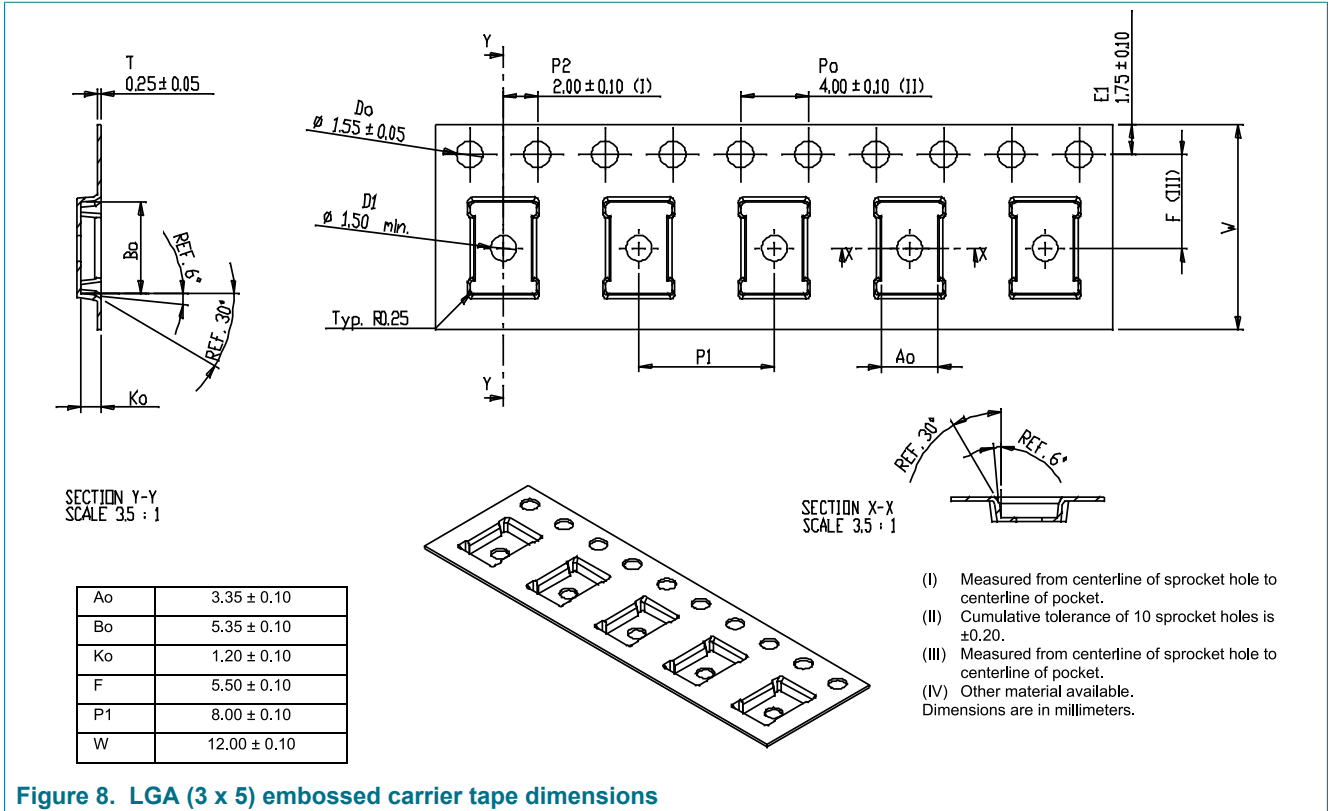

Figure 8. LGA (3 x 5) embossed carrier tape dimensions

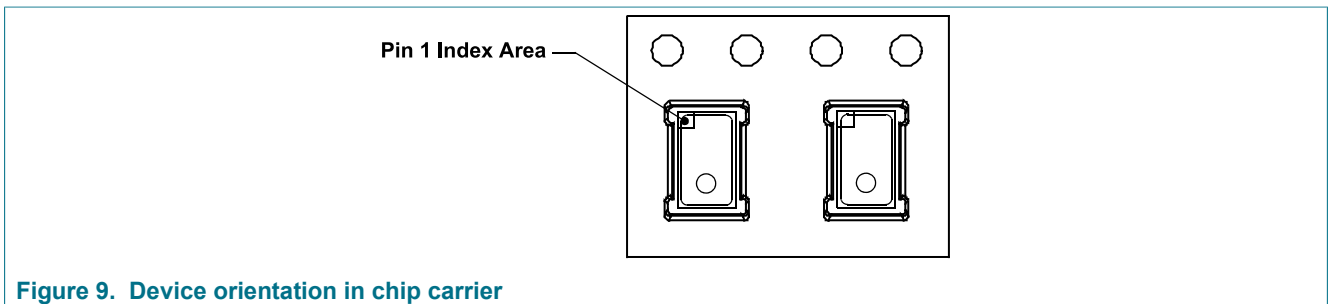

Figure 9. Device orientation in chip carrier

13 Soldering

1. Use SAC solder alloy, i.e., Sn-Ag-Cu, with a melting point of about 217 °C. It is recommended to use SAC305, i.e., Sn-3.0 wt.% Ag-0.5 wt.% Cu.
2. Reflow
 - Ramp up rate: 2 to 3 °C/s.
 - Preheat flat (soak): 110 to 130 s.
 - Reflow peak temperature: 250 °C to 260 °C (depends on exact SAC alloy composition).
 - Time above 217°C: 40 to 90s (depends on board type, thermal mass of the board/ quantities in the reflow).
 - Ramp down: 5 to 6 °C/s.
 - Using an inert reflow environment (with O₂ level about 5 to 15 ppm).

Note: *The stress level and signal offset of the device also depends on the board type, board core material, board thickness and metal finishing of the board.*

Please refer to NXP application note AN3150, Soldering Recommendations for Pressure Sensor Devices for any additional information.

14 Soldering/landing pad information

The LGA package is compliant with the RoHS standard. It is recommended to use a no-clean solder paste to reduce cleaning exposure to high pressure and chemical agents that can damage or reduce life span of the Pressure sensing element.

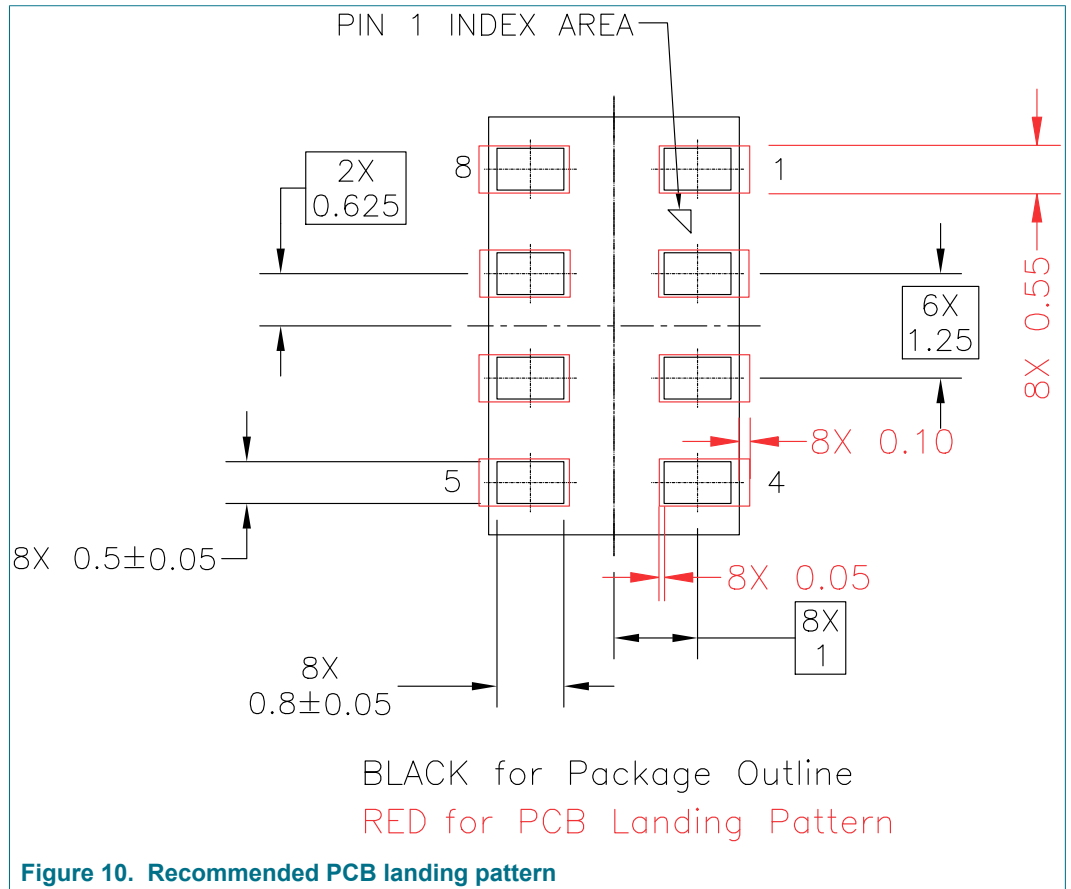

15 Revision history

Table 11. Revision history

Document ID	Release date	Data sheet status	Change notice	Supersedes
MPL115A2 v.10	20171010	Technical data	—	MPL115A2 v.9
Modifications:	<ul style="list-style-type: none"> • The format of this data sheet has been redesigned to comply with the new identity guidelines of NXP Semiconductors. • Legal texts have been adapted to the new company name where appropriate. • Removed the first paragraph of Section 7. • Added Section 7.1 and Section 7.2 in Section 7 "Handling and Board Mount Recommendations" • Updated Figure 7. No technical changes. 			
MPL115A2 v.9	10/2012	Technical data	—	MPL115A2 v.8
MPL115A2 v.8	06/2012	Technical data	—	—

16 Legal information

16.1 Data sheet status

Document status ^{[1][2]}	Product status ^[3]	Definition
[short] Data sheet: product preview	Development	This document contains certain information on a product under development. NXP reserves the right to change or discontinue this product without notice.
[short] Data sheet: advance information	Qualification	This document contains information on a new product. Specifications and information herein are subject to change without notice.
[short] Data sheet: technical data	Production	This document contains the product specification. NXP Semiconductors reserves the right to change the detail specifications as may be required to permit improvements in the design of its products.

[1] Please consult the most recently issued document before initiating or completing a design.

[2] The term 'short data sheet' is explained in section "Definitions".

[3] The product status of device(s) described in this document may have changed since this document was published and may differ in case of multiple devices. The latest product status information is available on the Internet at URL <http://www.nxp.com>.

16.2 Definitions

Draft — The document is a draft version only. The content is still under internal review and subject to formal approval, which may result in modifications or additions. NXP Semiconductors does not give any representations or warranties as to the accuracy or completeness of information included herein and shall have no liability for the consequences of use of such information.

Short data sheet — A short data sheet is an extract from a full data sheet with the same product type number(s) and title. A short data sheet is intended for quick reference only and should not be relied upon to contain detailed and full information. For detailed and full information see the relevant full data sheet, which is available on request via the local NXP Semiconductors sales office. In case of any inconsistency or conflict with the short data sheet, the full data sheet shall prevail.

Product specification — The information and data provided in a technical data data sheet shall define the specification of the product as agreed between NXP Semiconductors and its customer, unless NXP Semiconductors and customer have explicitly agreed otherwise in writing. In no event however, shall an agreement be valid in which the NXP Semiconductors product is deemed to offer functions and qualities beyond those described in the technical data data sheet.

16.3 Disclaimers

Limited warranty and liability — Information in this document is believed to be accurate and reliable. However, NXP Semiconductors does not give any representations or warranties, expressed or implied, as to the accuracy or completeness of such information and shall have no liability for the consequences of use of such information. NXP Semiconductors takes no responsibility for the content in this document if provided by an information source outside of NXP Semiconductors. In no event shall NXP Semiconductors be liable for any indirect, incidental, punitive, special or consequential damages (including - without limitation - lost profits, lost savings, business interruption, costs related to the removal or replacement of any products or rework charges) whether or not such damages are based on tort (including negligence), warranty, breach of contract or any other legal theory. Notwithstanding any damages that customer might incur for any reason whatsoever, NXP Semiconductors' aggregate and cumulative liability towards customer for the products described herein shall be limited in accordance with the Terms and conditions of commercial sale of NXP Semiconductors.

Right to make changes — NXP Semiconductors reserves the right to make changes to information published in this document, including without

limitation specifications and product descriptions, at any time and without notice. This document supersedes and replaces all information supplied prior to the publication hereof.

Suitability for use — NXP Semiconductors products are not designed, authorized or warranted to be suitable for use in life support, life-critical or safety-critical systems or equipment, nor in applications where failure or malfunction of an NXP Semiconductors product can reasonably be expected to result in personal injury, death or severe property or environmental damage. NXP Semiconductors and its suppliers accept no liability for inclusion and/or use of NXP Semiconductors products in such equipment or applications and therefore such inclusion and/or use is at the customer's own risk.

Applications — Applications that are described herein for any of these products are for illustrative purposes only. NXP Semiconductors makes no representation or warranty that such applications will be suitable for the specified use without further testing or modification. Customers are responsible for the design and operation of their applications and products using NXP Semiconductors products, and NXP Semiconductors accepts no liability for any assistance with applications or customer product design. It is customer's sole responsibility to determine whether the NXP Semiconductors product is suitable and fit for the customer's applications and products planned, as well as for the planned application and use of customer's third party customer(s). Customers should provide appropriate design and operating safeguards to minimize the risks associated with their applications and products. NXP Semiconductors does not accept any liability related to any default, damage, costs or problem which is based on any weakness or default in the customer's applications or products, or the application or use by customer's third party customer(s). Customer is responsible for doing all necessary testing for the customer's applications and products using NXP Semiconductors products in order to avoid a default of the applications and the products or of the application or use by customer's third party customer(s). NXP does not accept any liability in this respect.

Limiting values — Stress above one or more limiting values (as defined in the Absolute Maximum Ratings System of IEC 60134) will cause permanent damage to the device. Limiting values are stress ratings only and (proper) operation of the device at these or any other conditions above those given in the Recommended operating conditions section (if present) or the Characteristics sections of this document is not warranted. Constant or repeated exposure to limiting values will permanently and irreversibly affect the quality and reliability of the device.

Terms and conditions of commercial sale — NXP Semiconductors products are sold subject to the general terms and conditions of commercial sale, as published at <http://www.nxp.com/profile/terms>, unless otherwise agreed in a valid written individual agreement. In case an individual agreement is concluded only the terms and conditions of the respective agreement shall apply. NXP Semiconductors hereby expressly objects to

applying the customer's general terms and conditions with regard to the purchase of NXP Semiconductors products by customer.

No offer to sell or license — Nothing in this document may be interpreted or construed as an offer to sell products that is open for acceptance or the grant, conveyance or implication of any license under any copyrights, patents or other industrial or intellectual property rights.

Export control — This document as well as the item(s) described herein may be subject to export control regulations. Export might require a prior authorization from competent authorities.

Non-automotive qualified products — Unless this data sheet expressly states that this specific NXP Semiconductors product is automotive qualified, the product is not suitable for automotive use. It is neither qualified nor tested in accordance with automotive testing or application requirements. NXP Semiconductors accepts no liability for inclusion and/or use of non-automotive qualified products in automotive equipment or applications. In the event that customer uses the product for design-in and use in automotive applications to automotive specifications and standards, customer (a) shall

use the product without NXP Semiconductors' warranty of the product for such automotive applications, use and specifications, and (b) whenever customer uses the product for automotive applications beyond NXP Semiconductors' specifications such use shall be solely at customer's own risk, and (c) customer fully indemnifies NXP Semiconductors for any liability, damages or failed product claims resulting from customer design and use of the product for automotive applications beyond NXP Semiconductors' standard warranty and NXP Semiconductors' product specifications.

Translations — A non-English (translated) version of a document is for reference only. The English version shall prevail in case of any discrepancy between the translated and English versions.

16.4 Trademarks

Notice: All referenced brands, product names, service names and trademarks are the property of their respective owners.

NXP — is a trademark of NXP B.V.

Tables

Tab. 1.	Ordering information	2	Tab. 6.	I2C write commands	9
Tab. 2.	Ordering options	2	Tab. 7.	I2C write command description	9
Tab. 3.	Pin description	3	Tab. 8.	I2C read command description	10
Tab. 4.	Device memory map	6	Tab. 9.	Maximum ratings	13
Tab. 5.	Pressure, temperature and compensation coefficient specifications	7	Tab. 10.	Mechanical and electrical characteristics	13
			Tab. 11.	Revision history	20

Figures

Fig. 1.	Block diagram of MPL115A2	2	Fig. 7.	Package outline SOT1769-1 (TSON8)	15
Fig. 2.	Pin configuration	3	Fig. 8.	LGA (3 x 5) embossed carrier tape dimensions	17
Fig. 3.	Sequence flow chart	5	Fig. 9.	Device orientation in chip carrier	17
Fig. 4.	I2C read coefficient datagram	10	Fig. 10.	Recommended PCB landing pattern	19
Fig. 5.	I2C Start conversion datagram	11			
Fig. 6.	I2C read results datagram	11			

Contents

1	General description	1
2	Features	1
3	Applications	1
4	Ordering information	2
4.1	Ordering options	2
5	Block diagram	2
6	Pinning information	3
6.1	Pinning	3
6.2	Pin description	3
7	Handling and Board Mount Recommendations	3
7.1	Methods of Handling	3
7.2	Board Mount Recommendations	4
8	Functional description	5
8.1	Pressure, temperature and coefficient bit-width specifications	7
8.2	Compensation	7
8.3	Evaluation sequence, arithmetic circuits	8
8.4	I2C device read/write operations	9
8.5	Example of pressure compensated calculation in floating-point notation	12
9	Maximum ratings	13
10	Mechanical and electrical characteristics	13
11	Package outline	15
12	Packing information	17
13	Soldering	18
14	Soldering/landing pad information	18
15	Revision history	20
16	Legal information	21

Please be aware that important notices concerning this document and the product(s) described herein, have been included in section 'Legal information'.

© NXP B.V. 2017.

All rights reserved.

For more information, please visit: <http://www.nxp.com>

For sales office addresses, please send an email to: salesaddresses@nxp.com

Date of release: 10 October 2017
Document identifier: MPL115A2



Компания «ЭлектроПласт» предлагает заключение долгосрочных отношений при поставках импортных электронных компонентов на взаимовыгодных условиях!

Наши преимущества:

- Оперативные поставки широкого спектра электронных компонентов отечественного и импортного производства напрямую от производителей и с крупнейших мировых складов;
- Поставка более 17-ти миллионов наименований электронных компонентов;
- Поставка сложных, дефицитных, либо снятых с производства позиций;
- Оперативные сроки поставки под заказ (от 5 рабочих дней);
- Экспресс доставка в любую точку России;
- Техническая поддержка проекта, помощь в подборе аналогов, поставка прототипов;
- Система менеджмента качества сертифицирована по Международному стандарту ISO 9001;
- Лицензия ФСБ на осуществление работ с использованием сведений, составляющих государственную тайну;
- Поставка специализированных компонентов (Xilinx, Altera, Analog Devices, Intersil, Interpoint, Microsemi, Aeroflex, Peregrine, Syfer, Eurofarad, Texas Instrument, Miteq, Cobham, E2V, MA-COM, Hittite, Mini-Circuits, General Dynamics и др.);

Помимо этого, одним из направлений компании «ЭлектроПласт» является направление «Источники питания». Мы предлагаем Вам помощь Конструкторского отдела:

- Подбор оптимального решения, техническое обоснование при выборе компонента;
- Подбор аналогов;
- Консультации по применению компонента;
- Поставка образцов и прототипов;
- Техническая поддержка проекта;
- Защита от снятия компонента с производства.



Как с нами связаться

Телефон: 8 (812) 309 58 32 (многоканальный)

Факс: 8 (812) 320-02-42

Электронная почта: org@eplast1.ru

Адрес: 198099, г. Санкт-Петербург, ул. Калинина, дом 2, корпус 4, литера А.