

**PLEASE CHECK WWW.MOLEX.COM FOR LATEST PART INFORMATION**

**Part Number:** [5009130402](#)

**Status:** **Active**

**Description:** 0.40mm (.016") Pitch SlimStack™ Board-to-Board Receptacle, Surface Mount, Dual Row, Vertical Stacking, Mated Height of 1.80mm (071"), with Solder Tabs, 40 Circuits, Lead-free

**Documents:**

[3D Model](#)

[Drawing \(PDF\)](#)

[Product Specification PS-500913-001 \(PDF\)](#)

[RoHS Certificate of Compliance \(PDF\)](#)

**General**

Product Family	PCB Receptacles
Series	500913
Application	Board-to-Board
Comments	Solder Tab Plating: Lead-Free, Tin
Product Name	SlimStack™

**Physical**

Circuits (Loaded)	40
Circuits (maximum)	40
Color - Resin	Black
Durability (mating cycles max)	30
Glow-Wire Compliant	No
Lock to Mating Part	Yes
Mated Height (in)	0.071 In
Mated Height (mm)	1.80 mm
Material - Metal	Phosphor Bronze
Material - Plating Mating	Gold
Material - Plating Termination	Gold
Material - Resin	High Temperature Thermoplastic
Number of Rows	2
Orientation	Vertical
PC Tail Length (in)	0.000 In
PC Tail Length (mm)	0.00 mm
PCB Locator	No
PCB Retention	None
PCB Thickness Recommended (in)	0.000 In
PCB Thickness Recommended (mm)	0.00 mm
Packaging Type	Embossed Tape on Reel
Pitch - Mating Interface (in)	0.016 In
Pitch - Mating Interface (mm)	0.40 mm
Pitch - Term. Interface (in)	0.016 In
Pitch - Term. Interface (mm)	0.40 mm
Plating min: Mating (µin)	10
Plating min: Mating (µm)	0.25
Plating min: Termination (µin)	2
Plating min: Termination (µm)	0.05
Polarized to Mating Part	No
Polarized to PCB	No
Stackable	No
Surface Mount Compatible (SMC)	Yes
Temperature Range - Operating	-25°C to +85°C
Termination Interface: Style	Surface Mount

**Electrical**

Current - Maximum per Contact	0.3A
-------------------------------	------

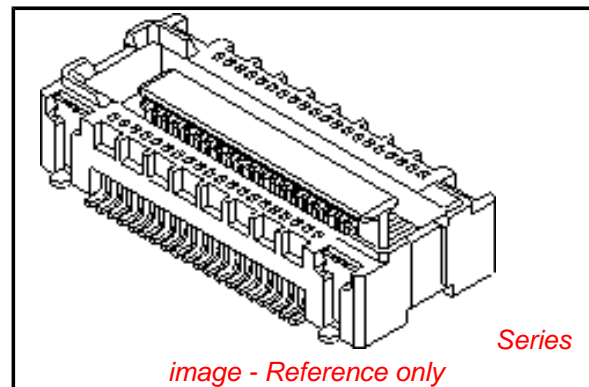

**EU RoHS**

**ELV and RoHS Compliant**

**REACH SVHC**

Not Reviewed

**Halogen-Free**

**Status**

**Not Reviewed**

**Need more information on product environmental compliance?**

Email [productcompliance@molex.com](mailto:productcompliance@molex.com)  
For a multiple part number RoHS Certificate of Compliance, [click here](#)

Please visit the [Contact Us](#) section for any non-product compliance questions.

**China RoHS**



**Search Parts in this Series**

500913Series

**Mates With**

55909 PCB Header

Voltage - Maximum

50V AC (RMS)/DC

**Material Info**

**Reference - Drawing Numbers**

Product Specification

PS-500913-001, RPS-500913-002, RPS-500913-003,  
RPS-500913-005

Sales Drawing

SD-500913-001, SD-500913-002

This document was generated on 04/19/2010

**PLEASE CHECK [WWW.MOLEX.COM](http://WWW.MOLEX.COM) FOR LATEST PART INFORMATION**

注記 NOTES:

- 使用材料 MATERIAL  
 ハウジング: 液晶ポリマー (LCP) ガラス充填 UL94V-0 (黒)  
 HOUSING: LIQUID CRYSTAL POLYMER (GLASS FILLED)  
 UL94V-0 (COLOR: BLACK)  
 ターミナル: リン青銅 (t=0.15)  
 TERMINAL: PHOSPHOR BRONZE (t=0.15)  
 金具: リン青銅 (t=0.15)  
 FITTING NAIL: PHOSPHOR BRONZE (t=0.15)
  - メッキ仕様 PLATING  
 ターミナル TERMINAL  
 金メッキ 0.2マイクロメートル以上 (コンタクト部)  
 GOLD 0.2MICROMETER MINIMUM (CONTACT AREA)  
 金メッキ 0.4マイクロメートル以下 (テール部)  
 GOLD 0.4MICROMETER MAXIMUM (TAIL AREA)  
 下地メッキ: ニッケルメッキ 1.5マイクロメートル以上  
 UNDER PLATING: NICKEL 1.5MICROMETER MINIMUM  
 \*コンタクト部とテール部はニッケルメッキによって分断されている金メッキです。  
 DIVIDE INTO PARTS THE GOLD PLATING OF THE CONTACT AND THE TAIL PART BY THE NICKEL PLATING.  
 金具 FITTING NAIL  
 錫メッキ 1.0マイクロメートル以上  
 TIN PLATING 1.0MICROMETER MINIMUM  
 下地メッキ: ニッケルメッキ 1.0マイクロメートル以上  
 UNDER PLATING: NICKEL 1.0MICROMETER MINIMUM
- △3 (全極数/2) = 偶数の場合に適用。  
 APPLY FOR (CIRCUIT/2) = EVEN.
- 嵌合相手: 55909シリーズ  
 MATE WITH: 55909 SERIES.
  - テール及び金具の平坦度は、0.1以下  
 TAIL AND FITTING NAIL COPLANARITY TO BE 0.1 MAXIMUM

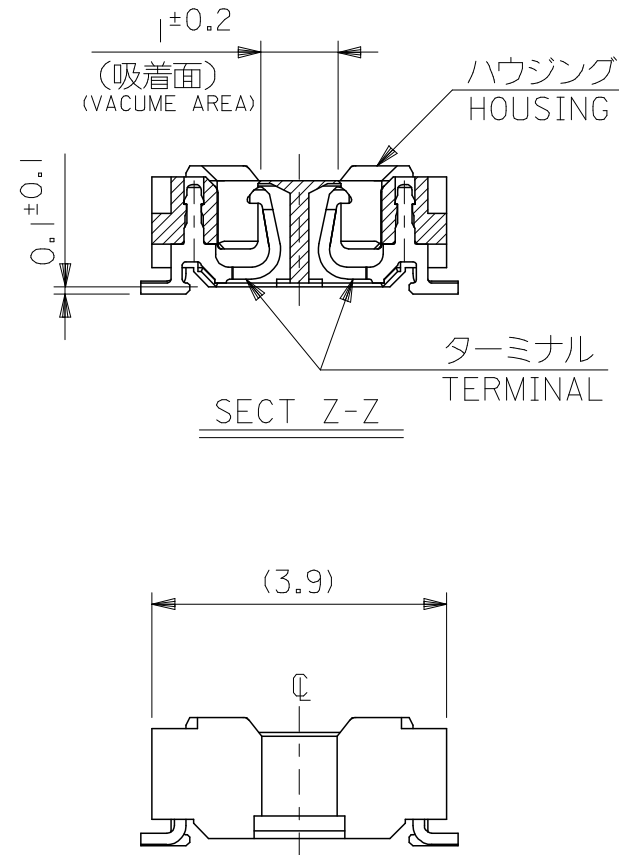
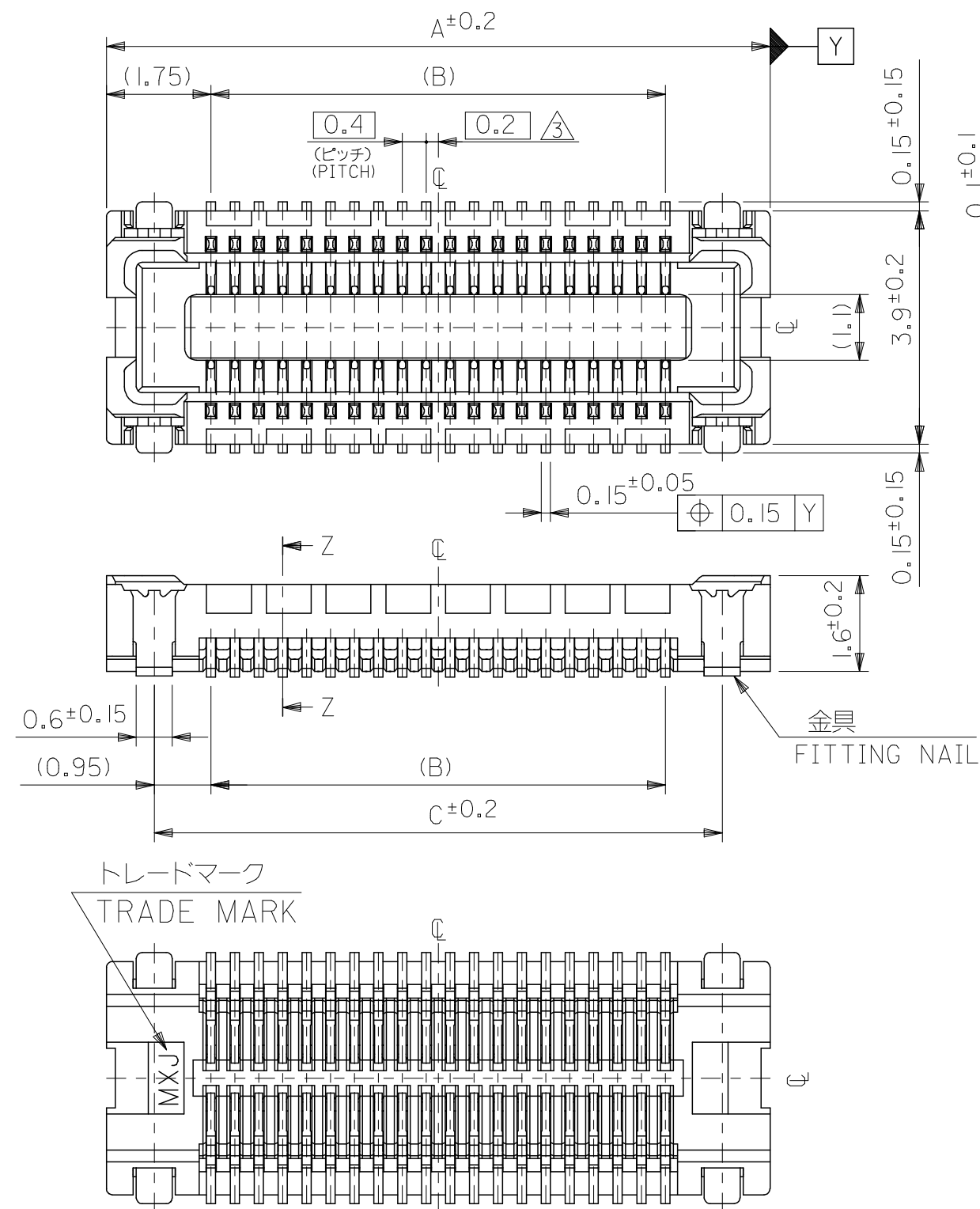

21.5	19.6	23.1	500913-1008	100
19.5	17.6	21.1	500913-0908	90
15.5	13.6	17.1	500913-0708	70
13.5	11.6	15.1	500913-0608	60
11.5	9.6	13.1	500913-0508	50
9.5	7.6	11.1	500913-0408	40
7.5	5.6	9.1	500913-0308	30
6.3	4.4	7.9	500913-0248	24
C	B	A	MATERIAL NO.	CIRCUIT

REVISED EC NO: J2007-1419 DRWN: MNABEI 2006/11/16 CHKD: KTOYODA 2006/11/20 APPR: NUKITA 2006/11/21	DESCRIPTION	GENERAL TOLERANCES (UNLESS SPECIFIED)		DIMENSION STYLE MM ONLY		500913-***8		MODEL NO.		
		10 UNDER ±---		DRAWN BY R. SUMIYA	DATE 2004/04/19	SCALE 10:1	DESIGN UNITS METRIC	THIRD ANGLE PROJECTION		
		10 <sup>OVER</sup> 30 UNDER ±---		CHECKED BY M. SASAO	DATE 2004/04/19	TITLE 0.4 B-TO-B CONN REC HSG ASSY (HGT=1.8MM) -LEAD FREE-				
		30 <sup>OVER</sup> ±---		APPROVED BY M. SASAO	DATE 2004/04/19					
		ANGULAR ±--- °		MATERIAL NO.		DOCUMENT NO.		SHEET NO.		
DRAFT WHERE APPLICABLE MUST REMAIN WITHIN DIMENSIONS		SEE CHART		SD-500913-001		1 OF 2				

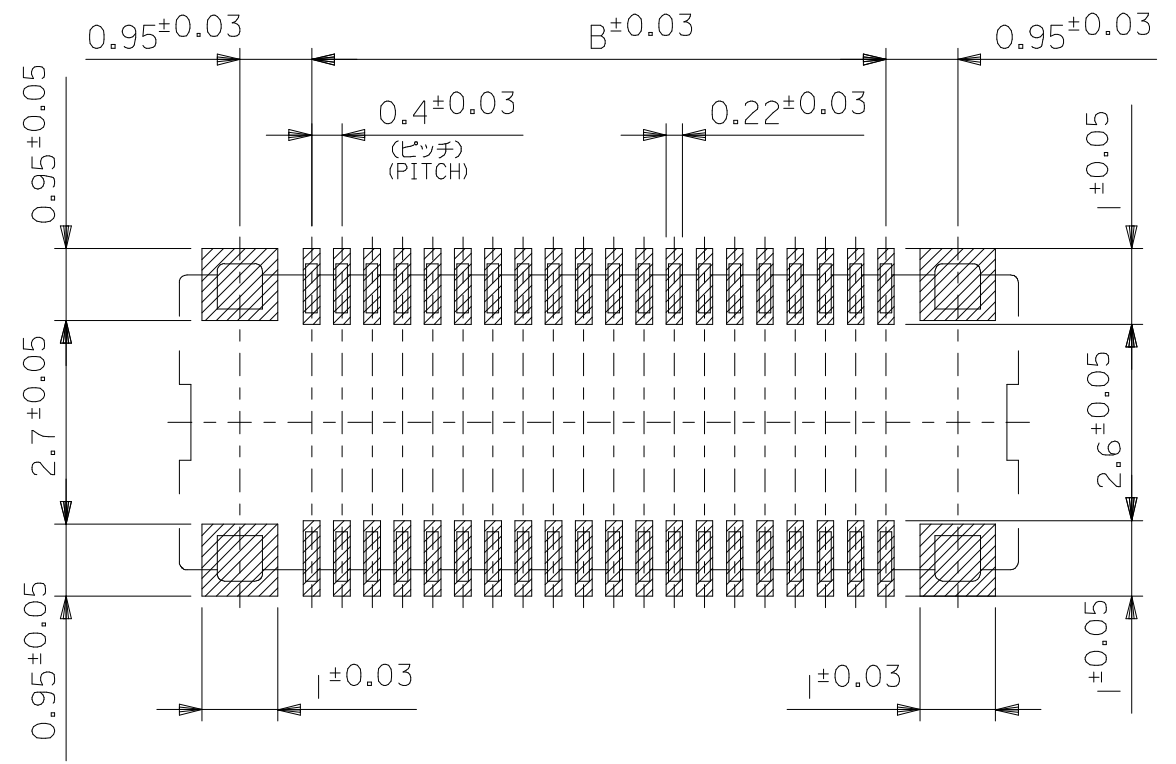

参考基板レイアウト (マウント面)  
P.C.BOARD PATTERN DIMENSION. (REFERENCE)  
(MOUNTING AREA)

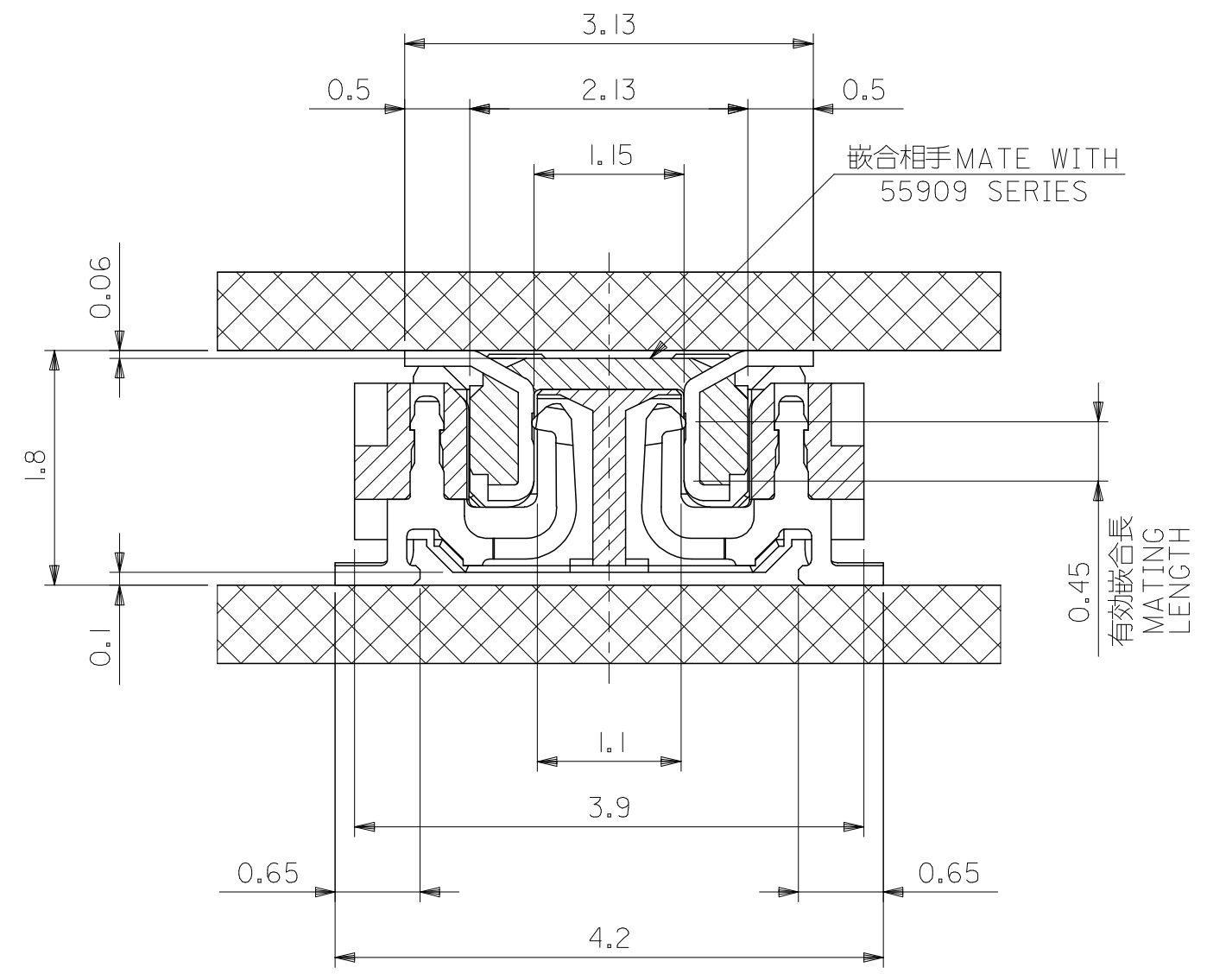

嵌合断面図 (参考)  
MATED DRAWING (REFERENCE)

REVISED EC NO: J2007-1419 DRWN: MNABEI 2006/11/16 CH'KD: KTOYODA 2006/11/20 APPR: NUKITA 2006/11/21	DESCRIPTION GENERAL TOLERANCES (UNLESS SPECIFIED)	DIMENSION STYLE MM ONLY		500913-***8 SCALE --- DESIGN UNITS METRIC		MODEL NO.	
		10 UNDER ± ---	DRAWN BY R. SUMIYA DATE 2004/04/19	TITLE 0.4 B-TO-B CONN REC HSG ASSY (HGT=1.8MM) -LEAD FREE-			
		10 <sup>OVER</sup> 30 UNDER ± ---	CHECKED BY M. SASAO DATE 2004/04/19				
		30 <sup>OVER</sup> ± ---	APPROVED BY M. SASAO DATE 2004/04/19	MOLEX MOLEX INCORPORATED			
		ANGULAR ± --- °	MATERIAL NO. SEE CHART				
DRAFT WHERE APPLICABLE MUST REMAIN WITHIN DIMENSIONS	SIZE A3	THIS DRAWING CONTAINS INFORMATION THAT IS PROPRIETARY TO MOLEX INCORPORATED AND SHOULD NOT BE USED WITHOUT WRITTEN PERMISSION					

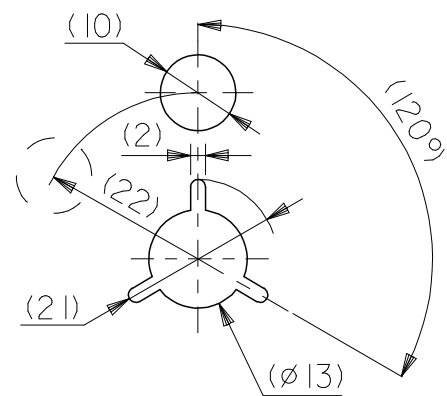
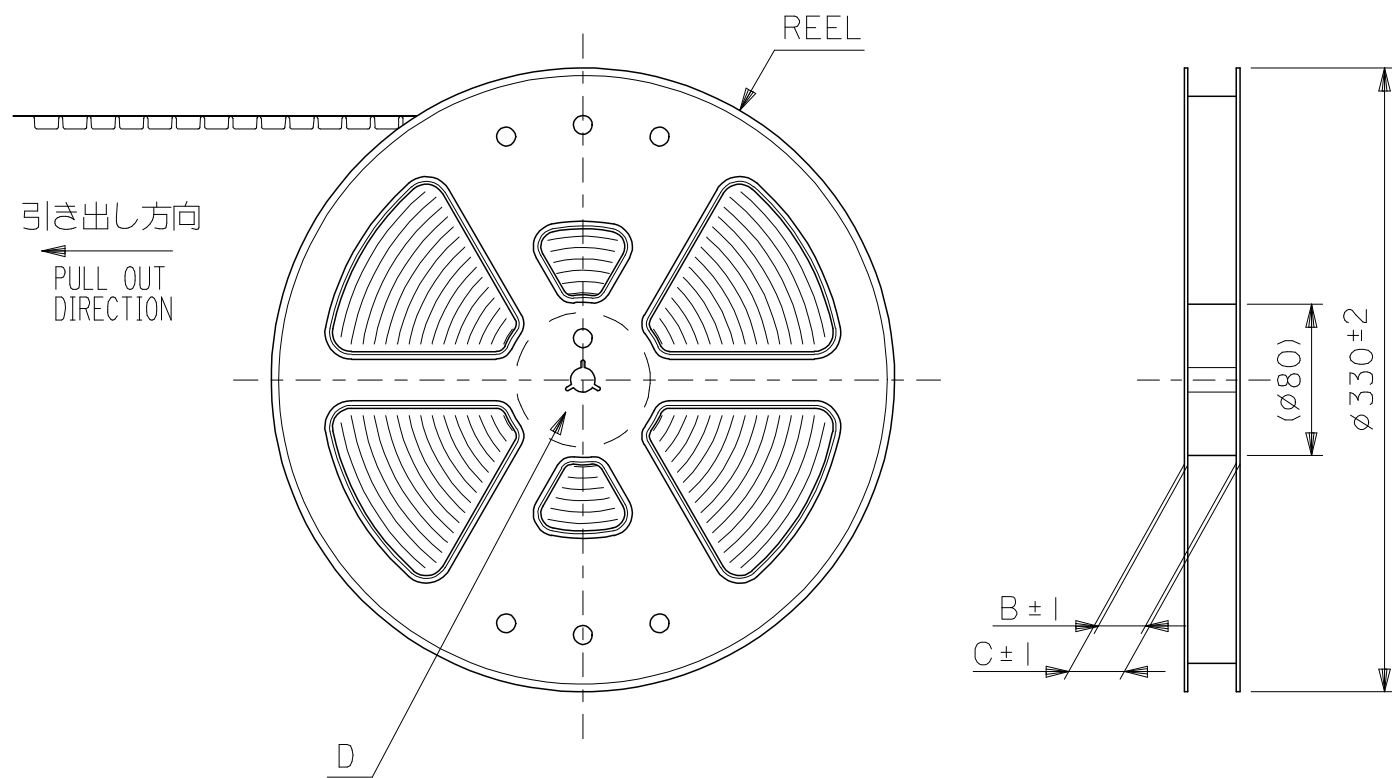

DETAIL D

NOTES

- 1. 製品詳細寸法については製品単体図面SD-500913-001を参照下さい。  
RE DETAILED DIMENSION, SEE PRODUCT DRAWING NO. SD-500913-001.
- 2. 梱包数量：1500個/リール  
NUMBER OF CONNECTORS : 1500PCS/REEL
- 3. リードテープ長さ LEAD TAPE LENGTH

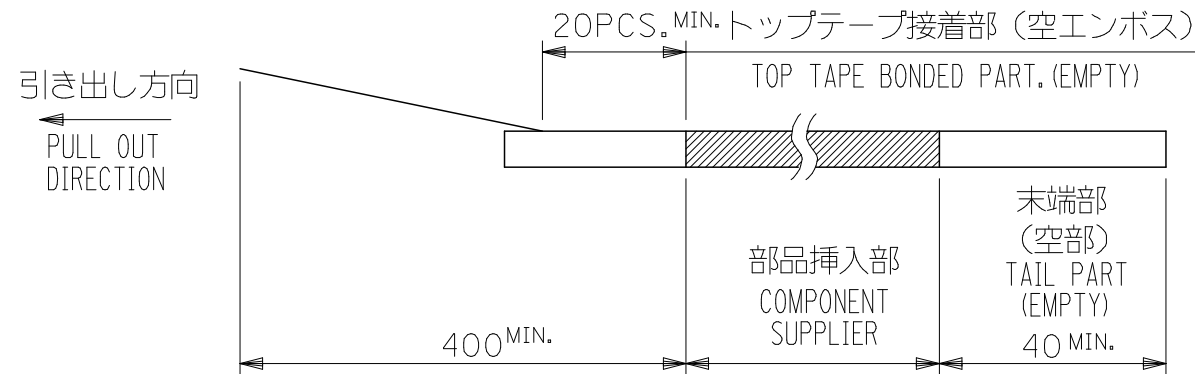

- 4. 材料 MATERIAL  
 キャリアテープ (CARRIER TAPE) : ポリプロピレン (POLYPROPYLENE)  
 トップテープ (TOPTAPE) : PET , PE , PEF  
 リール (REEL) : ポリスチレン (PS) <リサイクル材を含む>  
 POLYSTYRENE (PS) <RECYCLE MATERIAL CONTAINED>

REVISED EC NO: J2007-1419 DRWN: MNABEI 2006/11/16 CHKD: KTOYODA 2006/11/20 APPR: NUKITA 2006/11/21	DESCRIPTION	GENERAL TOLERANCES (UNLESS SPECIFIED)		DIMENSION STYLE MM ONLY		500913-***2		MODEL NO.		
		10 UNDER ± ---		DRAWN BY R. SUMIYA DATE 2004/04/19		SCALE ---	DESIGN UNITS METRIC	THIRD ANGLE PROJECTION		
		10 OVER 30 UNDER ± ---		CHECKED BY M. SASAO DATE 2004/04/19		TITLE 0.4 B-TO-B REC HSG ASSY (HGT=1.8) EMBSTP PKG -LEAD FREE-				
		30 OVER ± ---		APPROVED BY M. SASAO DATE 2004/04/19		MOLEX MOLEX INCORPORATED				
		ANGULAR ± --- °		MATERIAL NO. SEE CHART		DOCUMENT NO. SD-500913-002			SHEET NO. 1 OF 4	
		DRAFT WHERE APPLICABLE MUST REMAIN WITHIN DIMENSIONS		SIZE A3		THIS DRAWING CONTAINS INFORMATION THAT IS PROPRIETARY TO MOLEX INCORPORATED AND SHOULD NOT BE USED WITHOUT WRITTEN PERMISSION				

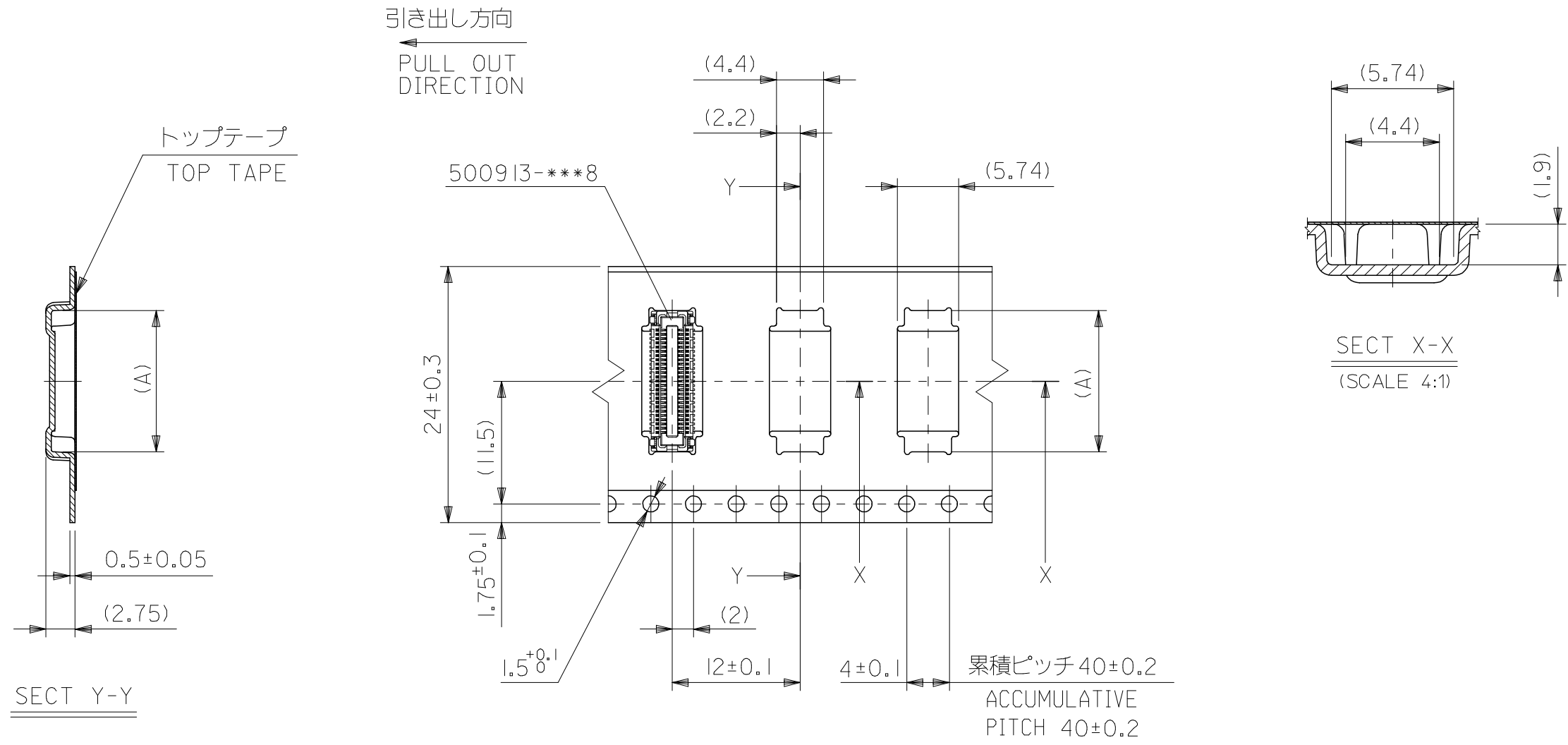

24mm幅キャリアテープ  
24mm WIDTH CARRIER TAPE

24	29.4	25.4	15.26	500913-0602	60
			13.26	500913-0502	50
			11.26	500913-0402	40
			9.26	500913-0302	30
			8.06	500913-0242	24
キャリアテープ幅 CARRIER TAPE WIDTH	C	B	(A)	MATERIAL NO.	CIRCUIT

REVISED EC NO: J2007-1419 DRWN: MNABEI 2006/11/16 CH'KD: KTOYODA 2006/11/20 APPR: NUKITA 2006/11/21	DESCRIPTION	GENERAL TOLERANCES (UNLESS SPECIFIED)		DIMENSION STYLE MM ONLY		500913-****2		MODEL NO.	
		10 UNDER	±---	DRAWN BY	DATE	SCALE	DESIGN UNITS	THIRD ANGLE PROJECTION 0.4 B-TO-B REC HSG ASSY (HGT=1.8) EMBSTP PKG -LEAD FREE-	
		10 OVER 30 UNDER	±---	R. SUMIYA	2004/04/19	2:1	METRIC		
		30 OVER	±---	CHECKED BY	DATE	MOLEX INCORPORATED DOCUMENT NO. SD-500913-002		SHEET NO. 2 OF 4	
		ANGULAR	±--- °	M. SASAO	2004/04/19				
DRAFT WHERE APPLICABLE MUST REMAIN WITHIN DIMENSIONS		SEE CHART		MATERIAL NO.		THIS DRAWING CONTAINS INFORMATION THAT IS PROPRIETARY TO MOLEX INCORPORATED AND SHOULD NOT BE USED WITHOUT WRITTEN PERMISSION			

引き出し方向  
PULL OUT  
DIRECTION

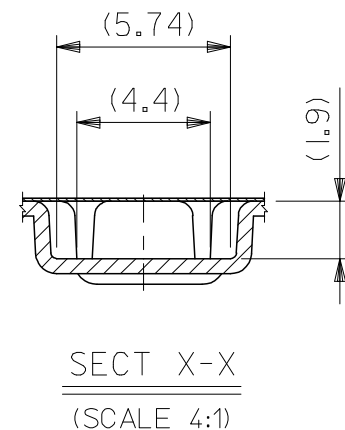
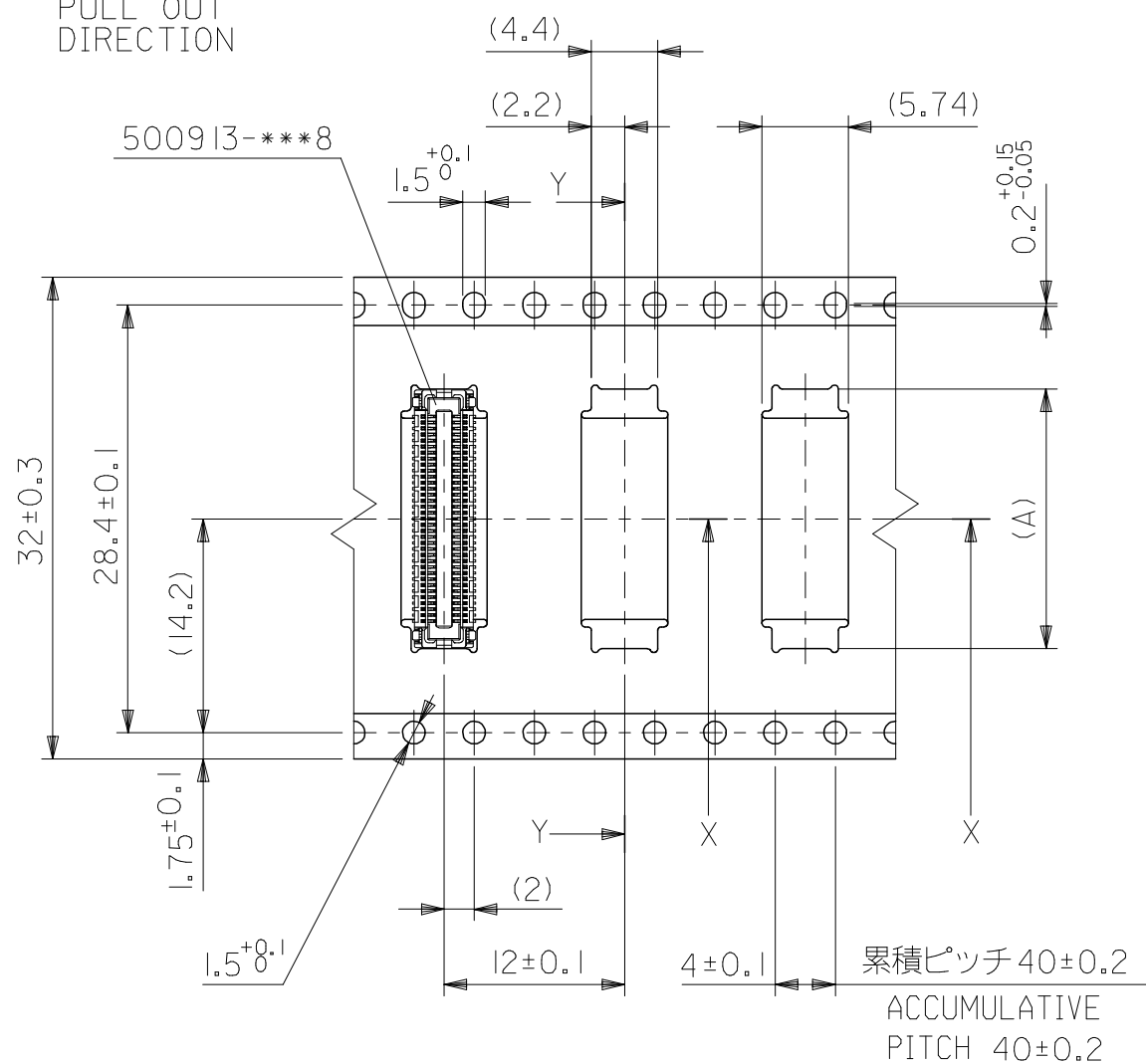
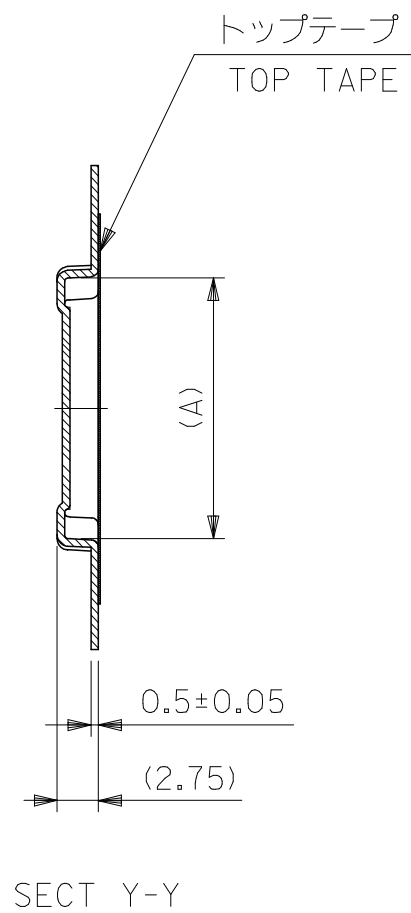

32mm幅キャリアテープ  
32mm WIDTH CARRIER TAPE

32	41.4	37.4	21.26	500913-0902	90
	37.4	33.4	17.26	500913-0702	70
キャリアテープ幅 CARRIER TAPE WIDTH	C	B	(A)	MATERIAL NO.	CIRCUIT

REVISED EC NO: J2007-1419 DRWN: MNABEI 2006/11/16 CH'KD: KTOYODA 2006/11/20 APPR: NUKITA 2006/11/21	DESCRIPTION	GENERAL TOLERANCES (UNLESS SPECIFIED)	DIMENSION STYLE MM ONLY	SCALE 2:1	DESIGN UNITS METRIC	MODEL NO. 500913-***2	THIRD ANGLE PROJECTION
	REV	10 UNDER	±---	DRAWN BY R. SUMIYA	DATE 2004/04/19	TITLE 0.4 B-TO-B REC HSG ASSY (HGT=1.8) EMBSTP PKG -LEAD FREE-	SHEET NO. 3 OF 4
		10 OVER 30 UNDER	±---	CHECKED BY M. SASAO	DATE 2004/04/19		
		30 OVER	±---	APPROVED BY M. SASAO	DATE 2004/04/19	MOLEX INCORPORATED	DOCUMENT NO. SD-500913-002
		ANGULAR	±--- °	MATERIAL NO.	SEE CHART		
	DRAFT WHERE APPLICABLE MUST REMAIN WITHIN DIMENSIONS		SIZE A3	THIS DRAWING CONTAINS INFORMATION THAT IS PROPRIETARY TO MOLEX INCORPORATED AND SHOULD NOT BE USED WITHOUT WRITTEN PERMISSION			

引き出し方向  
PULL OUT  
DIRECTION

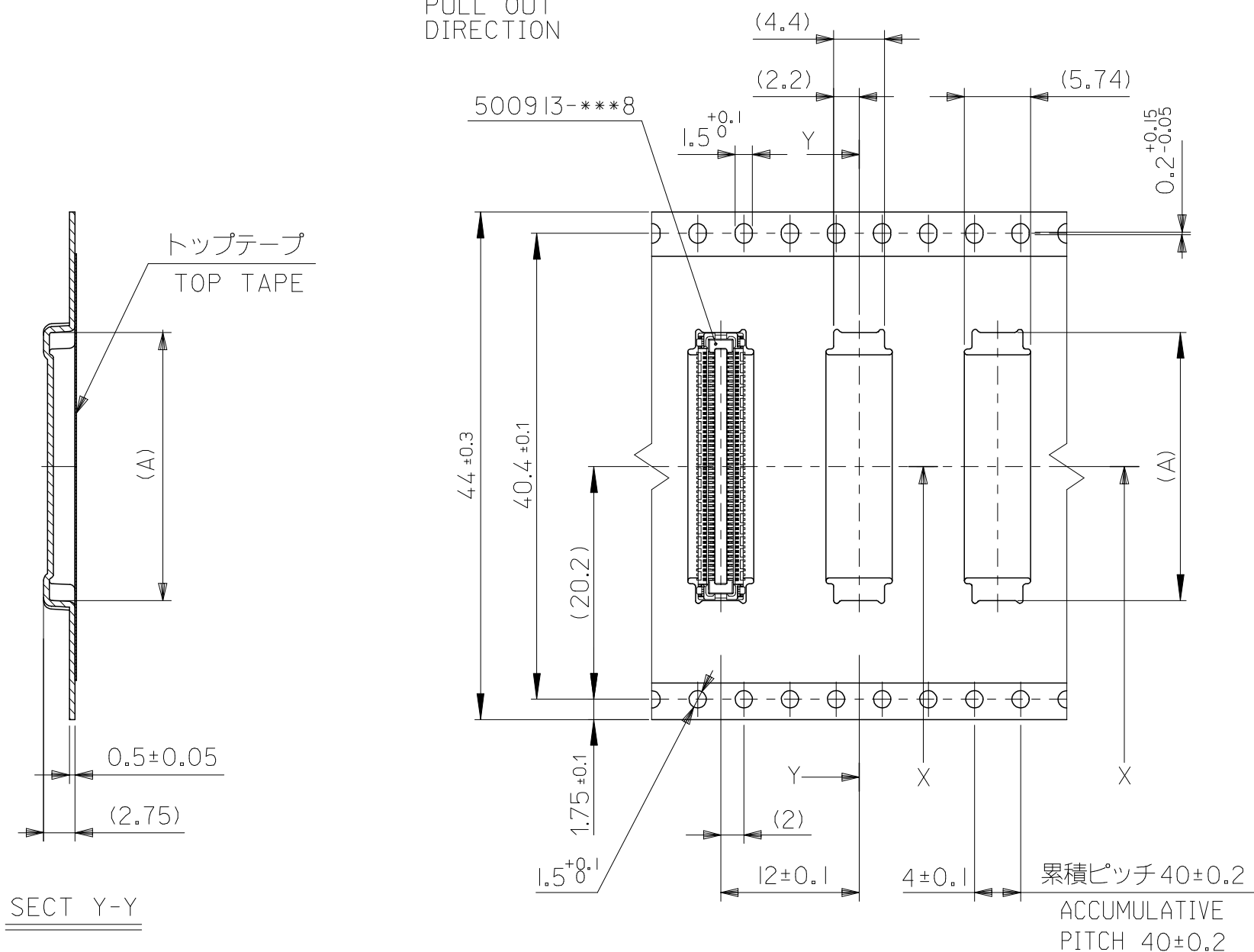

44 mm幅キャリアテープ  
44 mm WIDTH CARRIER TAPE

44	49.4	45.4	23.26	500913-1002	100
キャリアテープ幅 CARRIER TAPE WIDTH	C	B	(A)	MATERIAL NO.	CIRCUIT

REVISED EC NO: J2007-1419 DRWN: MNABEI 2006/11/16 CH'KD: KTOYD0A 2006/11/20 APPR: NUKITA 2006/11/21	DESCRIPTION GENERAL TOLERANCES (UNLESS SPECIFIED)	DIMENSION STYLE MM ONLY		SCALE 2:1		DESIGN UNITS METRIC		MODEL NO. 500913-***2		THIRD ANGLE PROJECTION	
		10 UNDER	± ---	DRAWN BY Y. SAKIYA	DATE 2004/07/30	TITLE 0.4 B-TO-B REC HSG ASSY (HGT=1.8) EMBSTP PKG -LEAD FREE-					
		10 OVER 30 UNDER	± ---	CHECKED BY M. SASAO	DATE 2004/07/30	MOLEX INCORPORATED					
		30 OVER	± ---	APPROVED BY M. SASAO	DATE 2004/07/30	MATERIAL NO. SEE CHART		DOCUMENT NO. SD-500913-002		SHEET NO. 4 OF 4	
		ANGULAR ± --- °		THIS DRAWING CONTAINS INFORMATION THAT IS PROPRIETARY TO MOLEX INCORPORATED AND SHOULD NOT BE USED WITHOUT WRITTEN PERMISSION							
DRAFT WHERE APPLICABLE MUST REMAIN WITHIN DIMENSIONS											





Компания «ЭлектроПласт» предлагает заключение долгосрочных отношений при поставках импортных электронных компонентов на взаимовыгодных условиях!

Наши преимущества:

- Оперативные поставки широкого спектра электронных компонентов отечественного и импортного производства напрямую от производителей и с крупнейших мировых складов;
- Поставка более 17-ти миллионов наименований электронных компонентов;
- Поставка сложных, дефицитных, либо снятых с производства позиций;
- Оперативные сроки поставки под заказ (от 5 рабочих дней);
- Экспресс доставка в любую точку России;
- Техническая поддержка проекта, помощь в подборе аналогов, поставка прототипов;
- Система менеджмента качества сертифицирована по Международному стандарту ISO 9001;
- Лицензия ФСБ на осуществление работ с использованием сведений, составляющих государственную тайну;
- Поставка специализированных компонентов (Xilinx, Altera, Analog Devices, Intersil, Interpoint, Microsemi, Aeroflex, Peregrine, Syfer, Eurofarad, Texas Instrument, Miteq, Cobham, E2V, MA-COM, Hittite, Mini-Circuits, General Dynamics и др.);

Помимо этого, одним из направлений компании «ЭлектроПласт» является направление «Источники питания». Мы предлагаем Вам помощь Конструкторского отдела:

- Подбор оптимального решения, техническое обоснование при выборе компонента;
- Подбор аналогов;
- Консультации по применению компонента;
- Поставка образцов и прототипов;
- Техническая поддержка проекта;
- Защита от снятия компонента с производства.



#### Как с нами связаться

**Телефон:** 8 (812) 309 58 32 (многоканальный)

**Факс:** 8 (812) 320-02-42

**Электронная почта:** [org@eplast1.ru](mailto:org@eplast1.ru)

**Адрес:** 198099, г. Санкт-Петербург, ул. Калинина, дом 2, корпус 4, литера А.