

Features

- Epitaxial Planar Die Construction
- Complementary PNP Types Available (DDTB)
- Built-In Biasing Resistors
- **Lead Free/RoHS Compliant (Note 2)**
- **"Green" Device, Note 3 and 4**

Mechanical Data

- Case: SOT-323
- Case Material: Molded Plastic, "Green" Molding Compound, Note 4. UL Flammability Classification Rating 94V-0
- Moisture Sensitivity: Level 1 per J-STD-020C
- Terminals: Solderable per MIL-STD-202, Method 208
- Terminal Connections: See Diagram
- Lead Free Plating (Matte Tin Finish annealed over Alloy 42 leadframe).
- Marking Information: See Table Below & Page 3
- Ordering Information: See Page 3
- Weight: 0.006 grams (approximate)

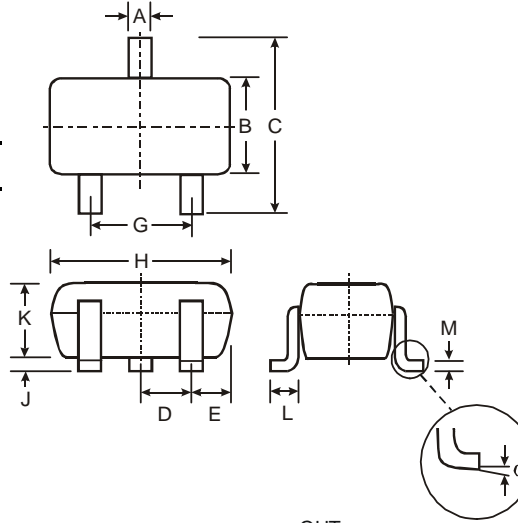

SOT-323		
Dim	Min	Max
A	0.25	0.40
B	1.15	1.35
C	2.00	2.20
D	0.65 Nominal	
E	0.30	0.40
G	1.20	1.40
H	1.80	2.20
J	0.0	0.10
K	0.90	1.00
L	0.25	0.40
M	0.10	0.18
α	0°	8°

All Dimensions in mm

P/N	R1 (NOM)	R2 (NOM)	MARKING
DDTD122LU	0.22K Ω	10K Ω	N75
DDTD142JU	0.47K Ω	10K Ω	N76
DDTD122TU	0.22K Ω	OPEN	N77
DDTD142TU	0.47K Ω	OPEN	N78

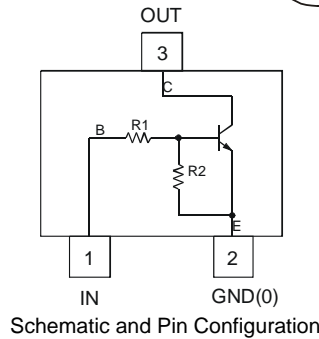

Maximum Ratings @T_A = 25°C unless otherwise specified

Characteristic	Symbol	Value	Unit
Supply Voltage, (3) to (2)	V _{CC}	50	V
Input Voltage, (1) to (2)	V _{IN}	-5 to +6	V
Input Voltage, (2) to (1)	V _{EBO (MAX)}	5	V
Output Current	I _C	500	mA
Power Dissipation	P _d	200	mW
Thermal Resistance, Junction to Ambient Air	R _{θJA}	625	°C/W
Operating and Storage Temperature Range	T _j , T _{STG}	-55 to +150	°C

- Notes:
1. Mounted on FR4 PC Board with recommended pad layout at <http://www.diodes.com/datasheets/ap02001.pdf>.
 2. No purposefully added lead.
 3. Diodes Inc.'s "Green" policy can be found on our website at http://www.diodes.com/products/lead_free/index.php.
 4. Product manufactured with Date Code 0627 (week 27, 2006) and newer are built with Green Molding Compound. Product manufactured prior to Date Code 0627 are built with Non-Green Molding Compound and may contain Halogens or Sb2O3 Fire Retardants.

Electrical Characteristics @T_A = 25°C unless otherwise specified

R1, R2 Types

Characteristic		Symbol	Min	Typ	Max	Unit	Test Condition
Input Voltage	DDTD122LU DDTD142JU	V _{I(off)}	0.3 0.3	—	—	V	V _{CC} = 5V, I _O = 100μA
	DDTD122LU DDTD142JU	V _{I(on)}	—	—	2.0 2.0	V	V _O = 0.3V, I _O = 20mA V _O = 0.3V, I _O = 20mA
Output Voltage		V _{O(on)}	—	—	0.3V	V	I _O /I _I = 50mA/2.5mA
Input Current	DDTD122LU DDTD142JU	I _I	—	—	28 13	mA	V _I = 5V
Output Current		I _{O(off)}	—	—	0.5	μA	V _{CC} = 50V, V _I = 0V
DC Current Gain	DDTD122LU DDTD142JU	G _I	56 56	—	—	—	V _O = 5V, I _O = 50mA
Gain-Bandwidth Product*		f _T	—	200	—	MHz	V _{CE} = 10V, I _E = 5mA, f = 100MHz

* Transistor - For Reference Only

Electrical Characteristics @T_A = 25°C unless otherwise specified

R1-Only, R2-Only Types

Characteristic		Symbol	Min	Typ	Max	Unit	Test Condition
Collector-Base Breakdown Voltage		BV _{CB0}	50	—	—	V	I _C = 50μA
Collector-Emitter Breakdown Voltage		BV _{CEO}	40	—	—	V	I _C = 1mA
Emitter-Base Breakdown Voltage	DDTD122TU DDTD142TU	BV _{EBO}	5	—	—	V	I _E = 50μA I _E = 50μA
Collector Cutoff Current		I _{CBO}	—	—	0.5	μA	V _{CB} = 50V
Emitter Cutoff Current	DDTD122TU DDTD142TU	I _{EBO}	— —	—	0.5 0.5	μA	V _{EB} = 4V
Collector-Emitter Saturation Voltage		V _{CE(sat)}	—	—	0.3	V	I _C = 50mA, I _B = 2.5mA
DC Current Transfer Ratio	DDTD122TU DDTD142TU	h _{FE}	100 100	250 250	600 600	—	I _C = 5mA, V _{CE} = 5V
Gain-Bandwidth Product*		f _T	—	200	—	MHz	V _{CE} = 10V, I _E = -5mA, f = 100MHz

* Transistor - For Reference Only

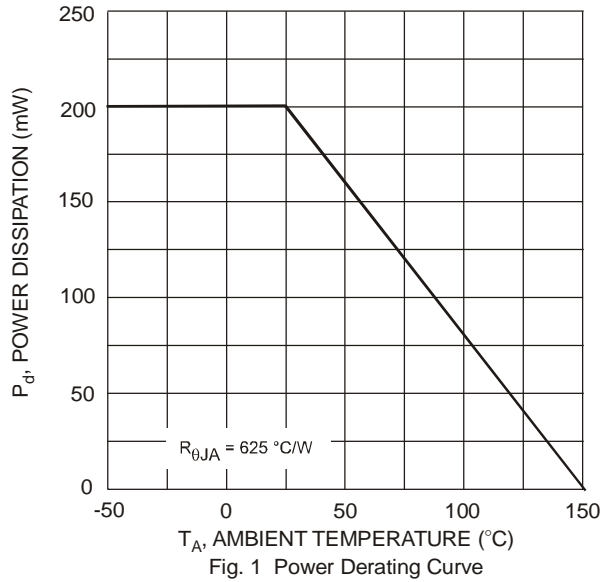

Ordering Information (Note 4 & 5)

Device	Packaging	Shipping
DDTD122LU-7-F	SOT-323	3000/Tape & Reel
DDTD142JU-7-F	SOT-323	3000/Tape & Reel
DDTD122TU-7-F	SOT-323	3000/Tape & Reel
DDTD142TU-7-F	SOT-323	3000/Tape & Reel

Notes: 5. For packaging details, go to our website at <http://www.diodes.com/datasheets/ap02007.pdf>.

Marking Information

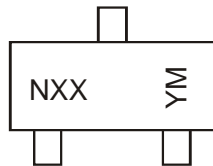

NXX = Product Type Marking Code
 See Page 1 Table
 YM = Date Code Marking
 Y = Year ex: T = 2006
 M = Month ex: 9 = September

Date Code Key

Year	2002	2003	2004	2005	2006	2007	2008	2009	2010	2011	2012
Code	N	P	R	S	T	U	V	W	X	Y	Z

Month	Jan	Feb	Mar	Apr	May	Jun	Jul	Aug	Sep	Oct	Nov	Dec
Code	1	2	3	4	5	6	7	8	9	O	N	D

IMPORTANT NOTICE

Diodes Incorporated and its subsidiaries reserve the right to make modifications, enhancements, improvements, corrections or other changes without further notice to any product herein. Diodes Incorporated does not assume any liability arising out of the application or use of any product described herein; neither does it convey any license under its patent rights, nor the rights of others. The user of products in such applications shall assume all risks of such use and will agree to hold Diodes Incorporated and all the companies whose products are represented on our website, harmless against all damages.

LIFE SUPPORT

Diodes Incorporated products are not authorized for use as critical components in life support devices or systems without the expressed written approval of the President of Diodes Incorporated.



Компания «ЭлектроПласт» предлагает заключение долгосрочных отношений при поставках импортных электронных компонентов на взаимовыгодных условиях!

Наши преимущества:

- Оперативные поставки широкого спектра электронных компонентов отечественного и импортного производства напрямую от производителей и с крупнейших мировых складов;
- Поставка более 17-ти миллионов наименований электронных компонентов;
- Поставка сложных, дефицитных, либо снятых с производства позиций;
- Оперативные сроки поставки под заказ (от 5 рабочих дней);
- Экспресс доставка в любую точку России;
- Техническая поддержка проекта, помощь в подборе аналогов, поставка прототипов;
- Система менеджмента качества сертифицирована по Международному стандарту ISO 9001;
- Лицензия ФСБ на осуществление работ с использованием сведений, составляющих государственную тайну;
- Поставка специализированных компонентов (Xilinx, Altera, Analog Devices, Intersil, Interpoint, Microsemi, Aeroflex, Peregrine, Syfer, Eurofarad, Texas Instrument, Miteq, Cobham, E2V, MA-COM, Hittite, Mini-Circuits, General Dynamics и др.);

Помимо этого, одним из направлений компании «ЭлектроПласт» является направление «Источники питания». Мы предлагаем Вам помощь Конструкторского отдела:

- Подбор оптимального решения, техническое обоснование при выборе компонента;
- Подбор аналогов;
- Консультации по применению компонента;
- Поставка образцов и прототипов;
- Техническая поддержка проекта;
- Защита от снятия компонента с производства.



Как с нами связаться

Телефон: 8 (812) 309 58 32 (многоканальный)

Факс: 8 (812) 320-02-42

Электронная почта: org@eplast1.ru

Адрес: 198099, г. Санкт-Петербург, ул. Калинина, дом 2, корпус 4, литера А.