

7WBD3306

2-Bit Translating Bus Switch

The 7WBD3306 is an advanced high-speed low-power 2-bit translating bus switch in ultra-small footprints.

Features

- High Speed: $t_{PD} = 0.25$ ns (Max) @ $V_{CC} = 4.5$ V
- 3Ω Switch Connection Between 2 Ports
- Power Down Protection Provided on Inputs
- Zero Bounce
- TTL-Compatible Control Inputs
- Ultra-Small Pb-Free Packages
- These are Pb-Free Devices



ON Semiconductor®

<http://onsemi.com>

MARKING DIAGRAMS

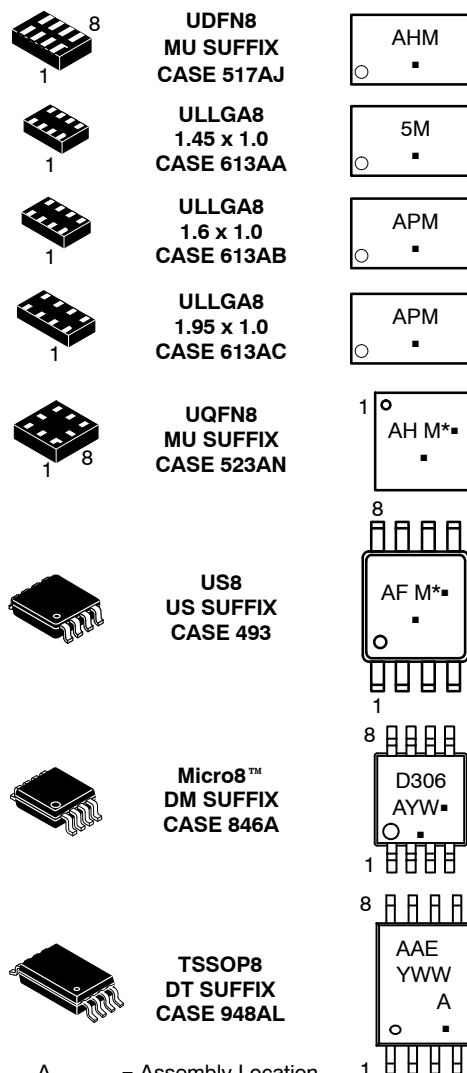

A = Assembly Location
 Y = Year
 W = Work Week
 M = Date Code
 ■ = Pb-Free Package

(Note: Microdot may be in either location)

*Date Code orientation may vary depending upon manufacturing location.

This document contains information on some products that are still under development. ON Semiconductor reserves the right to change or discontinue these products without notice.

ORDERING INFORMATION

See detailed ordering and shipping information in the package dimensions section on page 6 of this data sheet.

7WBD3306

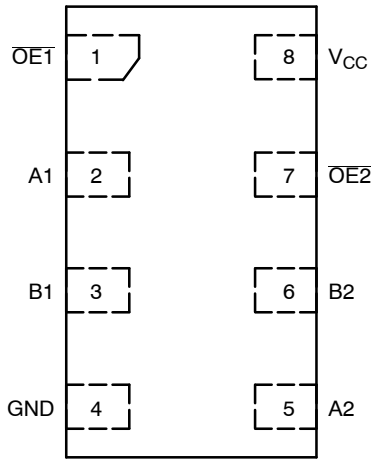

Figure 1. ULLGA8/UDFN8
(Top Thru-View)

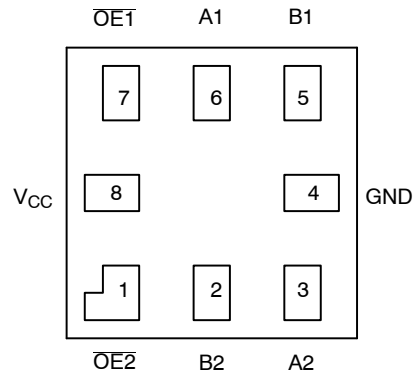

Figure 2. UQFN8
(Top Thru-View)

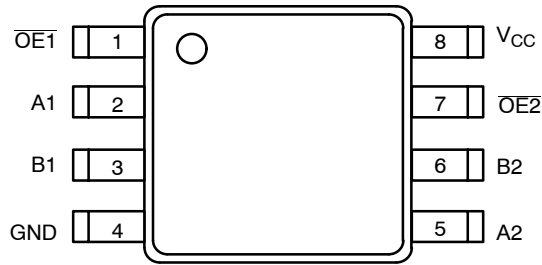

Figure 3. US8/Micro8/TSSOP8
(Top View)

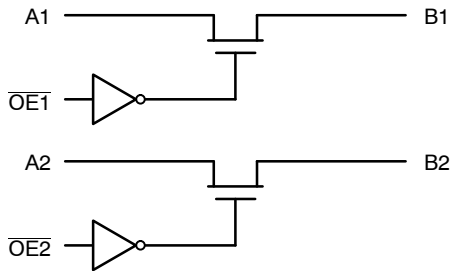

Figure 4. Logic Diagram

FUNCTION TABLE

| Input $\overline{OE}n$ | Function |
|------------------------|------------|
| L | $Bn = An$ |
| H | Disconnect |

MAXIMUM RATINGS

| Symbol | Parameter | Value | Unit |
|----------------------|--|----------------------|------|
| V _{CC} | DC Supply Voltage | -0.5 to +7.0 | V |
| V _{IN} | Control Pin Input Voltage | -0.5 to +7.0 | V |
| V _{I/O} | Switch Input / Output Voltage | -0.5 to +7.0 | V |
| I _{IK} | Control Pin DC Input Diode Current V _{IN} < GND | -50 | mA |
| I _{OK} | Switch I/O Port DC Diode Current V _{I/O} < GND | -50 | mA |
| I _O | ON-State Switch Current | ± 128 | mA |
| | Continuous Current Through V _{CC} or GND | ± 150 | mA |
| I _{CC} | DC Supply Current Per Supply Pin | ± 150 | mA |
| I _{GND} | DC Ground Current per Ground Pin | ± 150 | mA |
| T _{STG} | Storage Temperature Range | -65 to +150 | °C |
| T _L | Lead Temperature, 1 mm from Case for 10 Seconds | 260 | °C |
| T _J | Junction Temperature Under Bias | 150 | °C |
| θ _{JA} | Thermal Resistance US8 (Note 1) UDFN8 UQFN8 ULLGA8 Micro8 TSSOP8 | 251 | °C/W |
| | | 111 | |
| | | 208 | |
| | | 455 | |
| | | 392 | |
| | | 150 | |
| P _D | Power Dissipation in Still Air at 85°C US8 UDFN8 UQFN8 ULLGA8 Micro8 TSSOP8 | 498 | mW |
| | | 1127 | |
| | | 601 | |
| | | 274 | |
| | | 319 | |
| | | 833 | |
| MSL | Moisture Sensitivity | Level 1 | |
| F _R | Flammability Rating Oxygen Index: 28 to 34 | UL 94 V-0 @ 0.125 in | |
| V _{ESD} | ESD Withstand Voltage Human Body Mode (Note 2) Machine Model (Note 3) Charged Device Model (Note 4) | > 2000 | V |
| | | > 200 | |
| | | N/A | |
| I _{LATCHUP} | Latchup Performance Above V _{CC} and Below GND at 125°C (Note 5) | ± 200 | mA |

Stresses exceeding Maximum Ratings may damage the device. Maximum Ratings are stress ratings only. Functional operation above the Recommended Operating Conditions is not implied. Extended exposure to stresses above the Recommended Operating Conditions may affect device reliability.

1. Measured with minimum pad spacing on an FR4 board, using 10 mm-by-1 inch, 2 ounce copper trace no air flow.
2. Tested to EIA / JESD22-A114-A.
3. Tested to EIA / JESD22-A115-A.
4. Tested to JESD22-C101-A.
5. Tested to EIA / JESD78.

RECOMMENDED OPERATING CONDITIONS

| Symbol | Parameter | Min | Max | Unit |
|------------------|---|-----|------|------|
| V _{CC} | Positive DC Supply Voltage | 4.0 | 5.5 | V |
| V _{IN} | Control Pin Input Voltage | 0 | 5.5 | V |
| V _{I/O} | Switch Input / Output Voltage | 0 | 5.5 | V |
| T _A | Operating Free-Air Temperature | -55 | +125 | °C |
| Δt / ΔV | Input Transition Rise or Fall Rate Control Input Switch I/O | 0 | 5 | nS/V |
| | | 0 | DC | |

7WBD3306

DC ELECTRICAL CHARACTERISTICS

| Symbol | Parameter | Conditions | V _{CC} (V) | T _A = 25°C | | | T _A = -55°C to +125°C | | Unit |
|------------------|---|---|------------------------|-----------------------|--------|--------------|-------------------------------------|--------------|----------|
| | | | | Min | Typ | Max | Min | Max | |
| V _{IK} | Clamp Diode Voltage | I _{I/O} = -18 mA | 4.5 | | | -1.2 | | -1.2 | V |
| V _{IH} | High-Level Input Voltage (Control) | | 4.0 to 5.5 | 2.0 | | | 2.0 | | V |
| V _{IL} | Low-Level Input Voltage (Control) | | 4.0 to 5.5 | | | 0.8 | | 0.8 | V |
| V _{OH} | Output Voltage High | See Figure 5 | | | | | | | |
| I _{IN} | Input Leakage Current | 0 ≤ V _{IN} ≤ 5.5 V | 5.5 | | | ±0.1 | | ±1.0 | μA |
| I _{OFF} | Power Off Leakage Current | V _{I/O} = 0 to 5.5 V | 0 | | | ±0.1 | | ±1.0 | μA |
| I _{CC} | Quiescent Supply Current | I _O = 0, V _{IN} = V _{CC} or 0 V OE1 = OE2 = GND OE1 = OE2 = V _{CC} | 5.5 | | | ±1.0 ±0.1 | | ±1.0 ±1.0 | mA μA |
| ΔI _{CC} | Increase in Supply Current (Control Pin) | One input at 3.4 V; Other inputs at V _{CC} or GND | 5.5 | | | | | 2.5 | mA |
| R _{ON} | Switch ON Resistance | V _{I/O} = 0, I _{I/O} = 64 mA I _{I/O} = 30 mA | 4.5 | | 3 3 | 7 7 | | 7 7 | Ω |
| | | V _{I/O} = 2.4, I _{I/O} = 15 mA | | | 15 | 50 | | 50 | |
| | | V _{I/O} = 2.4, I _{I/O} = 15 mA | 4.0 | | 50 | 70 | | 70 | |

AC ELECTRICAL CHARACTERISTICS

| Symbol | Parameter | Test Condition | V _{CC} (V) | T _A = 25 °C | | | T _A = -55°C to +125°C | | Unit |
|----------------------|-------------------------------|----------------------------|------------------------|------------------------|-----|------|-------------------------------------|------|------|
| | | | | Min | Typ | Max | Min | Max | |
| t _{PD} | Propagation Delay, Bus to Bus | See Figure 6 | 4.0 to 5.5 | | | 0.25 | | 0.25 | ns |
| t _{EN} | Output Enable Time | See Figure 6 | 4.5 to 5.5 | 0.8 | 2.5 | 4.2 | 0.8 | 4.2 | ns |
| | | | 4.0 | 0.8 | 3.0 | 4.6 | 0.8 | 4.6 | |
| t _{DIS} | Output Disable Time | | 4.5 to 5.5 | 0.8 | 3.0 | 4.8 | 0.8 | 4.8 | ns |
| | | | 4.0 | 0.8 | 2.9 | 4.4 | 0.8 | 4.4 | |
| C _{IN} | Control Input Capacitance | V _{IN} = 5 or 0 V | 5.0 | | 2.5 | | | | pF |
| C _{IO(ON)} | Switch On Capacitance | Switch ON | 5.0 | | 10 | | | | pF |
| C _{IO(OFF)} | Switch Off Capacitance | Switch OFF | 5.0 | | 5 | | | | pF |

7WBD3306

TYPICAL DC CHARACTERISTICS

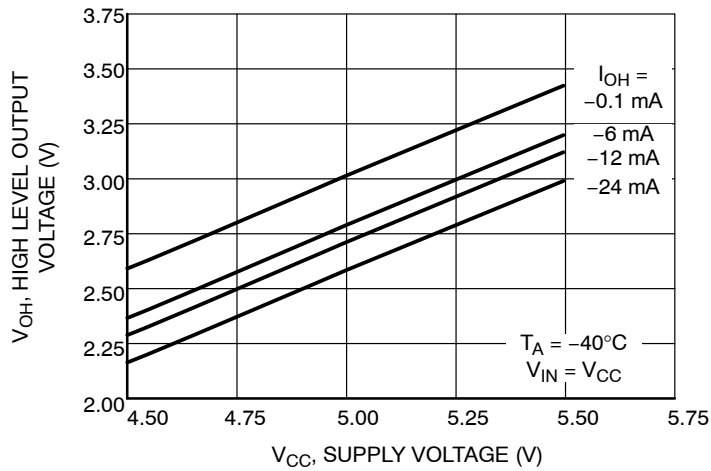
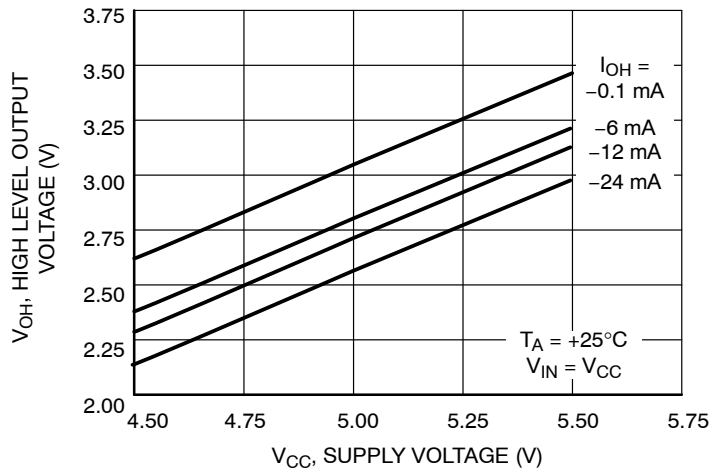
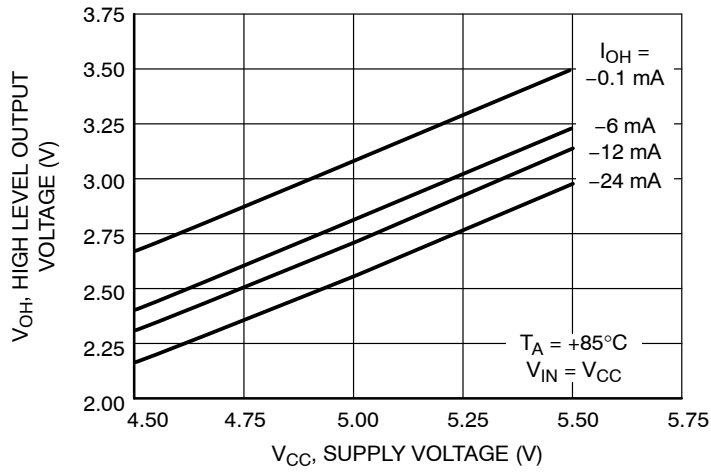

Figure 5. Output Voltage High vs Supply Voltage

7WBD3306

AC LOADING AND WAVEFORMS

Parameter Measurement Information



* C_L includes probes and jig capacitance.

| Test | S1 |
|-------------------|------|
| t_{PD} | Open |
| t_{PLZ}/t_{PZL} | 7 V |
| t_{PHZ}/t_{PZH} | Open |

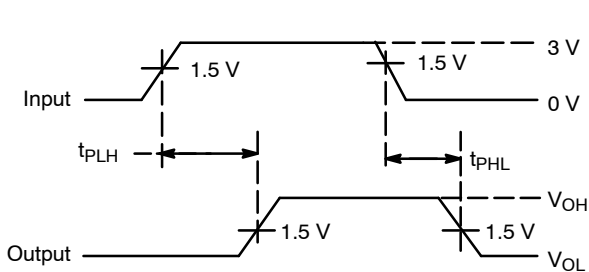

**Voltage Waveforms
Propagation Delay Times**

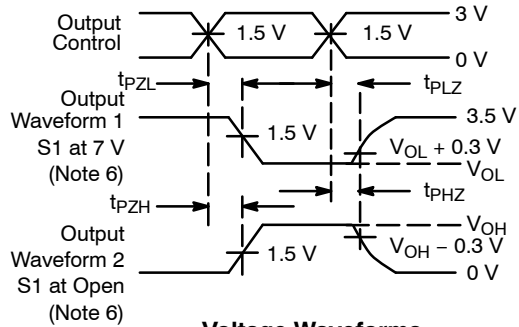

**Voltage Waveforms
Enable and Disable Times**

- Waveform 1 is for an output with internal conditions such that the output is low, except when disabled by the output control. Waveform 2 is for an output with internal conditions such that the output is high, except when disabled by the output control.
- All input pulses are supplied by generators having the following characteristics: $PRR \leq 10 \text{ MHz}$, $Z_O = 50 \Omega$, $t_r \leq 2.5 \text{ ns}$, $t_f \leq 2.5 \text{ ns}$.
- The outputs are measured one at a time, with one transition per measurement.
- t_{PLZ} and t_{PHZ} are the same as t_{DIS} .
- t_{PZL} and t_{PZH} are the same as t_{EN} .
- t_{PHL} and t_{PLH} are the same as t_{PD} .

Figure 6. t_{PD} , t_{EN} , t_{DIS} Loading and Waveforms

ORDERING INFORMATION

| Device | Package | Shipping† |
|-----------------|-------------------------------------|--|
| 7WBD3306USG | US8 (Pb-Free) | 3000 / Tape & Reel |
| 7WBD3306MUTAG | UDFN8 (Pb-Free) | 3000 / Tape & Reel |
| 7WBD3306AMUTCG | UQFN8 (Pb-Free) | 3000 / Tape & Reel |
| 7WBD3306AMX1TCG | ULLGA8 – 0.5 mm Pitch (Pb-Free) | 3000 / Tape & Reel |
| 7WBD3306BMX1TCG | ULLGA8 – 0.4 mm Pitch (Pb-Free) | 3000 / Tape & Reel |
| 7WBD3306CMX1TCG | ULLGA8 – 0.35 mm Pitch (Pb-Free) | 3000 / Tape & Reel |
| 7WBD3306DMR2G | Micro8 (Pb-Free) | 4000 / Tape & Reel (In Development) |
| 7WBD3306DTR2G | TSSOP8 (Pb-Free) | 4000 / Tape & Reel |

†For information on tape and reel specifications, including part orientation and tape sizes, please refer to our Tape and Reel Packaging Specifications Brochure, BRD8011/D.

7WBD3306

PACKAGE DIMENSIONS

UDFN8 1.8 x 1.2, 0.4P
CASE 517AJ-01
ISSUE O

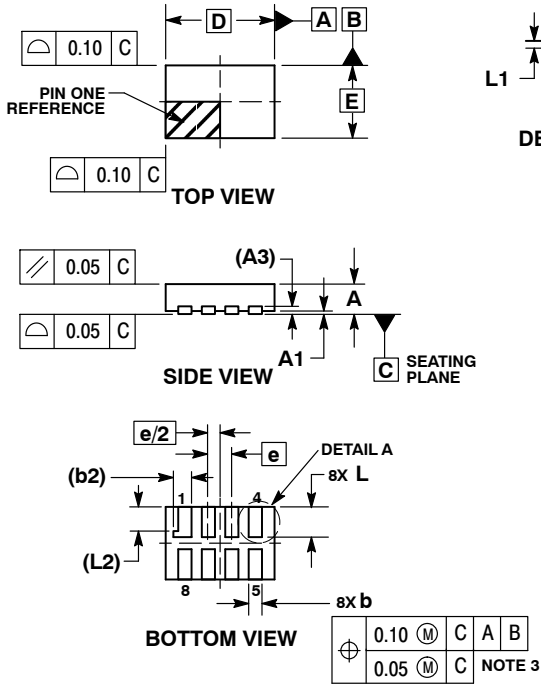

NOTES:

1. DIMENSIONING AND TOLERANCING PER ASME Y14.5M, 1994.
2. CONTROLLING DIMENSION: MILLIMETERS.
3. DIMENSION b APPLIES TO PLATED TERMINAL AND IS MEASURED BETWEEN 0.15 AND 0.30 mm FROM TERMINAL TIP.
4. MOLD FLASH ALLOWED ON TERMINALS ALONG EDGE OF PACKAGE. FLASH MAY NOT EXCEED 0.03 ONTO BOTTOM SURFACE OF TERMINALS.
5. DETAIL A SHOWS OPTIONAL CONSTRUCTION FOR TERMINALS.

| MILLIMETERS | | |
|-------------|-------|------|
| DIM | MIN | MAX |
| A | 0.45 | 0.55 |
| A1 | 0.00 | 0.05 |
| A3 | 0.127 | REF |
| b | 0.15 | 0.25 |
| b2 | 0.30 | REF |
| D | 1.80 | BSC |
| E | 1.20 | BSC |
| e | 0.40 | BSC |
| L | 0.45 | 0.55 |
| L1 | 0.00 | 0.03 |
| L2 | 0.40 | REF |

**MOUNTING FOOTPRINT*
SOLDERMASK DEFINED**

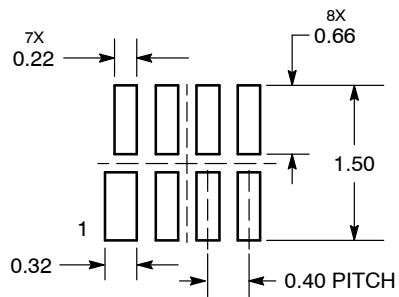

DIMENSIONS: MILLIMETERS

*For additional information on our Pb-Free strategy and soldering details, please download the ON Semiconductor Soldering and Mounting Techniques Reference Manual, SOLDERRM/D.

7WBD3306

PACKAGE DIMENSIONS

ULLGA8 1.45x1.0, 0.35P
CASE 613AA-01
ISSUE A

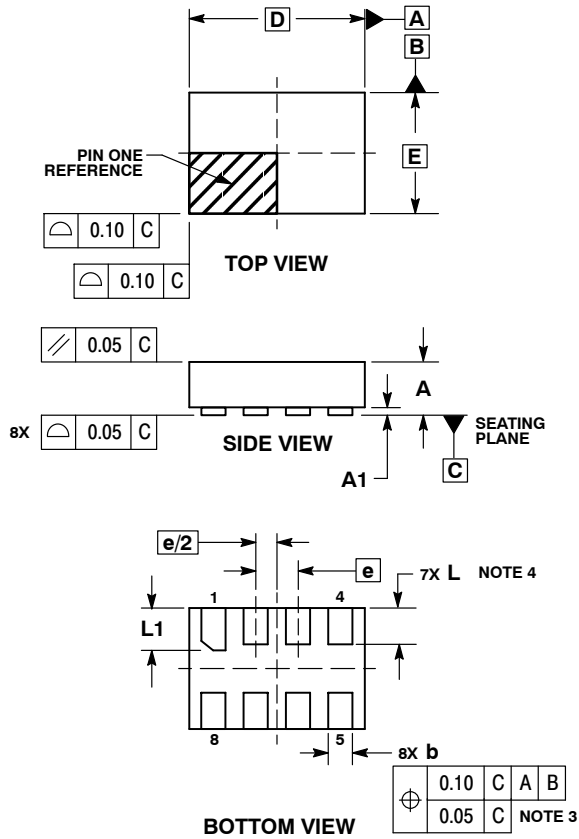

NOTES:

1. DIMENSIONING AND TOLERANCING PER ASME Y14.5M, 1994.
2. CONTROLLING DIMENSION: MILLIMETERS.
3. DIMENSION b APPLIES TO PLATED TERMINAL AND IS MEASURED BETWEEN 0.15 AND 0.30 mm FROM THE TERMINAL TIP.
4. A MAXIMUM OF 0.05 PULL BACK OF THE PLATED TERMINAL FROM THE EDGE OF THE PACKAGE IS ALLOWED.

| MILLIMETERS | | |
|-------------|----------|------|
| DIM | MIN | MAX |
| A | --- | 0.40 |
| A1 | 0.00 | 0.05 |
| b | 0.15 | 0.25 |
| D | 1.45 BSC | |
| E | 1.00 BSC | |
| e | 0.35 BSC | |
| L | 0.25 | 0.35 |
| L1 | 0.30 | 0.40 |

**MOUNTING FOOTPRINT
SOLDERMASK DEFINED***

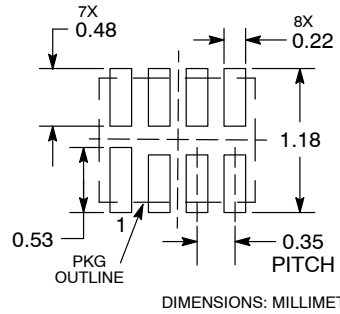

*For additional information on our Pb-Free strategy and soldering details, please download the ON Semiconductor Soldering and Mounting Techniques Reference Manual, SOLDERRM/D.

7WBD3306

PACKAGE DIMENSIONS

ULLGA8 1.6x1.0, 0.4P
CASE 613AB-01
ISSUE A

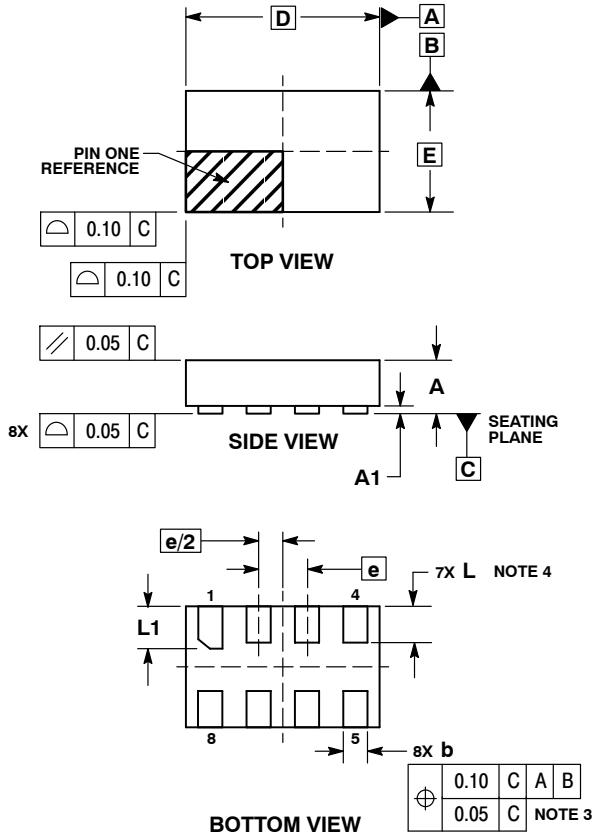

NOTES:

1. DIMENSIONING AND TOLERANCING PER ASME Y14.5M, 1994.
2. CONTROLLING DIMENSION: MILLIMETERS.
3. DIMENSION b APPLIES TO PLATED TERMINAL AND IS MEASURED BETWEEN 0.15 AND 0.30 mm FROM THE TERMINAL TIP.
4. A MAXIMUM OF 0.05 PULL BACK OF THE PLATED TERMINAL FROM THE EDGE OF THE PACKAGE IS ALLOWED.

| MILLIMETERS | | |
|-------------|----------|------|
| DIM | MIN | MAX |
| A | --- | 0.40 |
| A1 | 0.00 | 0.05 |
| b | 0.15 | 0.25 |
| D | 1.60 BSC | |
| E | 1.00 BSC | |
| e | 0.40 BSC | |
| L | 0.25 | 0.35 |
| L1 | 0.30 | 0.40 |

**MOUNTING FOOTPRINT
SOLDERMASK DEFINED***

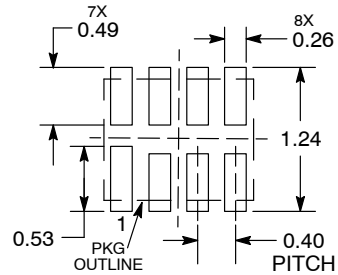

DIMENSIONS: MILLIMETERS

*For additional information on our Pb-Free strategy and soldering details, please download the ON Semiconductor Soldering and Mounting Techniques Reference Manual, SOLDERRM/D.

7WBD3306

PACKAGE DIMENSIONS

ULLGA8 1.95x1.0, 0.5P
CASE 613AC-01
ISSUE A

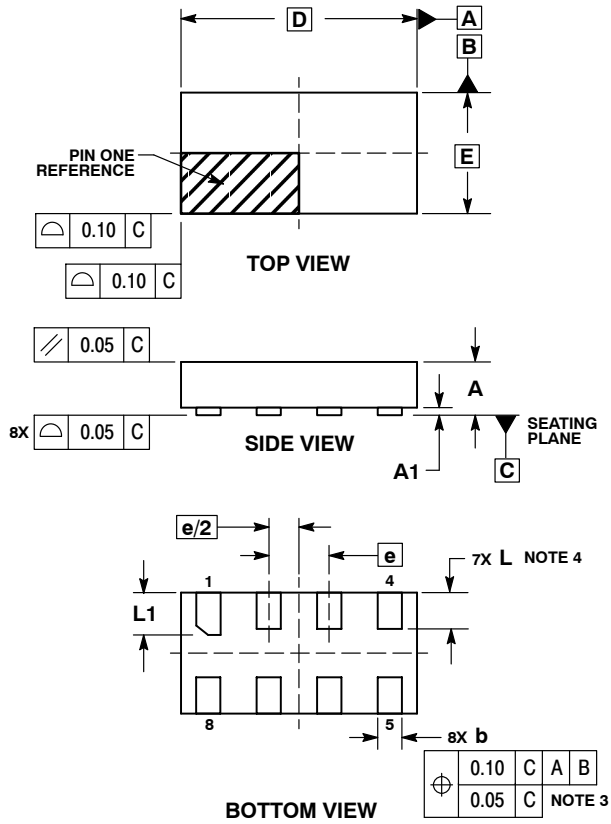

NOTES:

1. DIMENSIONING AND TOLERANCING PER ASME Y14.5M, 1994.
2. CONTROLLING DIMENSION: MILLIMETERS.
3. DIMENSION b APPLIES TO PLATED TERMINAL AND IS MEASURED BETWEEN 0.15 AND 0.30 mm FROM THE TERMINAL TIP.
4. A MAXIMUM OF 0.05 PULL BACK OF THE PLATED TERMINAL FROM THE EDGE OF THE PACKAGE IS ALLOWED.

| MILLIMETERS | | |
|-------------|----------|------|
| DIM | MIN | MAX |
| A | --- | 0.40 |
| A1 | 0.00 | 0.05 |
| b | 0.15 | 0.25 |
| D | 1.95 BSC | |
| E | 1.00 BSC | |
| e | 0.50 BSC | |
| L | 0.25 | 0.35 |
| L1 | 0.30 | 0.40 |

**MOUNTING FOOTPRINT
SOLDERMASK DEFINED***



DIMENSIONS: MILLIMETERS

*For additional information on our Pb-Free strategy and soldering details, please download the ON Semiconductor Soldering and Mounting Techniques Reference Manual, SOLDERRM/D.

7WBD3306

PACKAGE DIMENSIONS

UQFN8, 1.6x1.6, 0.5P CASE 523AN-01 ISSUE O

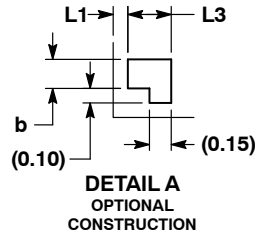
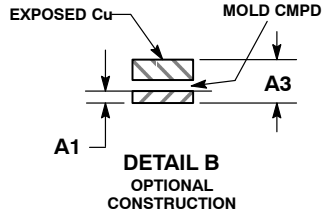
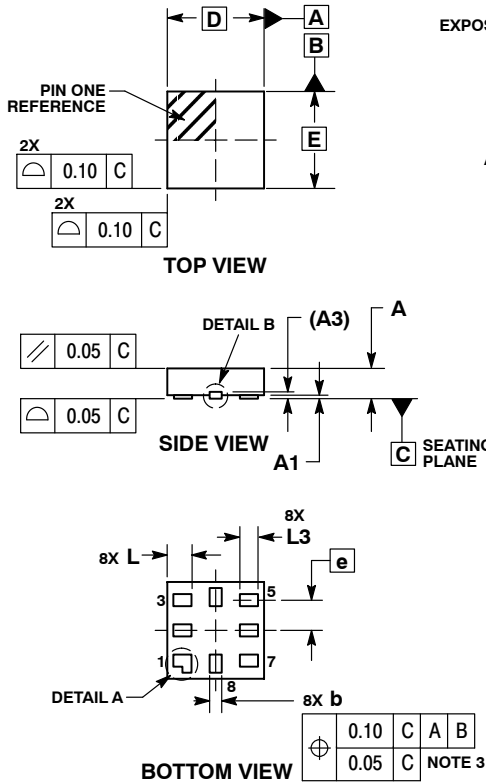

NOTES:

1. DIMENSIONING AND TOLERANCING PER ASME Y14.5M, 1994.
2. CONTROLLING DIMENSION: MILLIMETERS.
3. DIMENSION b APPLIES TO PLATED TERMINAL AND IS MEASURED BETWEEN 0.15 AND 0.30 mm FROM THE TERMINAL TIP.

| MILLIMETERS | | |
|-------------|------|------|
| DIM | MIN | MAX |
| A | 0.45 | 0.60 |
| A1 | 0.00 | 0.05 |
| A3 | 0.13 | REF |
| b | 0.15 | 0.25 |
| D | 1.60 | BSC |
| E | 1.60 | BSC |
| e | 0.50 | BSC |
| L | 0.35 | 0.45 |
| L1 | --- | 0.15 |
| L3 | 0.25 | 0.35 |

SOLDERING FOOTPRINT*

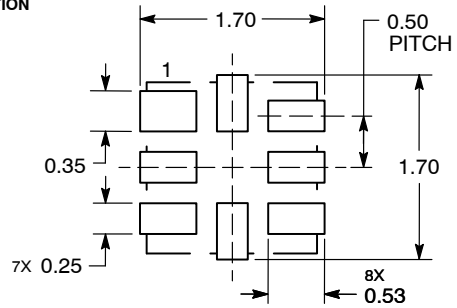

DIMENSIONS: MILLIMETERS

*For additional information on our Pb-Free strategy and soldering details, please download the ON Semiconductor Soldering and Mounting Techniques Reference Manual, SOLDERRM/D.

7WBD3306

PACKAGE DIMENSIONS

US8
CASE 493-02
ISSUE B

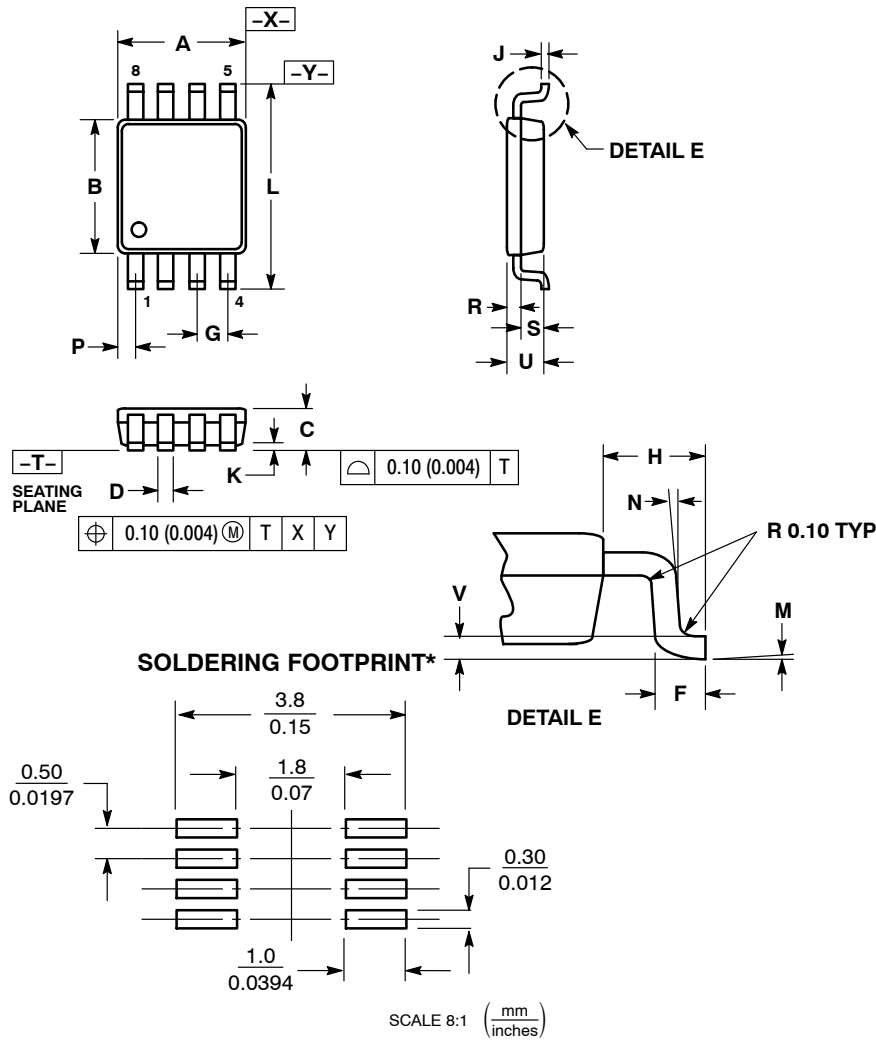

NOTES:

1. DIMENSIONING AND TOLERANCING PER ANSI Y14.5M, 1982.
2. CONTROLLING DIMENSION: MILLIMETERS.
3. DIMENSION "A" DOES NOT INCLUDE MOLD FLASH, PROTRUSION OR GATE BURR. MOLD FLASH, PROTRUSION AND GATE BURR SHALL NOT EXCEED 0.140 MM (0.0055") PER SIDE.
4. DIMENSION "B" DOES NOT INCLUDE INTER-LEAD FLASH OR PROTRUSION. INTER-LEAD FLASH AND PROTRUSION SHALL NOT EXCEED 0.140 (0.0055") PER SIDE.
5. LEAD FINISH IS SOLDER PLATING WITH THICKNESS OF 0.0076-0.0203 MM. (300-800 Å).
6. ALL TOLERANCE UNLESS OTHERWISE SPECIFIED ±0.0508 (0.0002").

| DIM | MILLIMETERS | | INCHES | |
|-----|-------------|------|-----------|-------|
| | MIN | MAX | MIN | MAX |
| A | 1.90 | 2.10 | 0.075 | 0.083 |
| B | 2.20 | 2.40 | 0.087 | 0.094 |
| C | 0.60 | 0.90 | 0.024 | 0.035 |
| D | 0.17 | 0.25 | 0.007 | 0.010 |
| F | 0.20 | 0.35 | 0.008 | 0.014 |
| G | 0.50 BSC | | 0.020 BSC | |
| H | 0.40 REF | | 0.016 REF | |
| J | 0.10 | 0.18 | 0.004 | 0.007 |
| K | 0.00 | 0.10 | 0.000 | 0.004 |
| L | 3.00 | 3.20 | 0.118 | 0.126 |
| M | 0° | 6° | 0° | 6° |
| N | 5° | 10° | 5° | 10° |
| P | 0.23 | 0.34 | 0.010 | 0.013 |
| R | 0.23 | 0.33 | 0.009 | 0.013 |
| S | 0.37 | 0.47 | 0.015 | 0.019 |
| U | 0.60 | 0.80 | 0.024 | 0.031 |
| V | 0.12 BSC | | 0.005 BSC | |

*For additional information on our Pb-Free strategy and soldering details, please download the ON Semiconductor Soldering and Mounting Techniques Reference Manual, SOLDERRM/D.

7WBD3306

PACKAGE DIMENSIONS

Micro8™
CASE 846A-02
ISSUE H

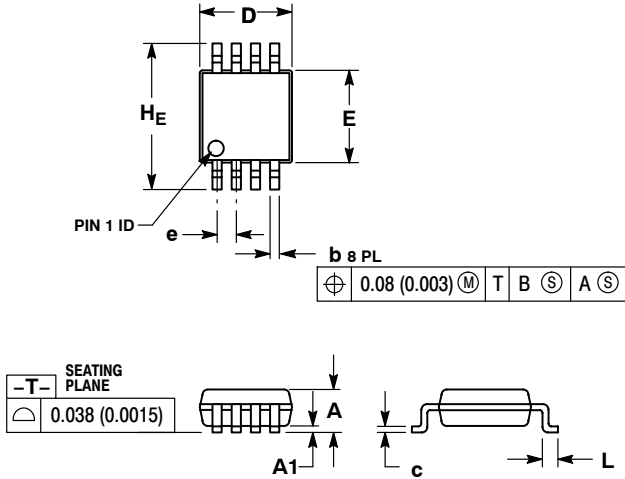

NOTES:

1. DIMENSIONING AND TOLERANCING PER ANSI Y14.5M, 1982.
2. CONTROLLING DIMENSION: MILLIMETER.
3. DIMENSION A DOES NOT INCLUDE MOLD FLASH, PROTRUSIONS OR GATE BURRS. MOLD FLASH, PROTRUSIONS OR GATE BURRS SHALL NOT EXCEED 0.15 (0.006) PER SIDE.
4. DIMENSION B DOES NOT INCLUDE INTERLEAD FLASH OR PROTRUSION. INTERLEAD FLASH OR PROTRUSION SHALL NOT EXCEED 0.25 (0.010) PER SIDE.
5. 846A-01 OBSOLETE, NEW STANDARD 846A-02.

| DIM | MILLIMETERS | | | INCHES | | |
|-----|-------------|------|------|-----------|-------|-------|
| | MIN | NOM | MAX | MIN | NOM | MAX |
| A | -- | -- | 1.10 | -- | -- | 0.043 |
| A1 | 0.05 | 0.08 | 0.15 | 0.002 | 0.003 | 0.006 |
| b | 0.25 | 0.33 | 0.40 | 0.010 | 0.013 | 0.016 |
| c | 0.13 | 0.18 | 0.23 | 0.005 | 0.007 | 0.009 |
| D | 2.90 | 3.00 | 3.10 | 0.114 | 0.118 | 0.122 |
| E | 2.90 | 3.00 | 3.10 | 0.114 | 0.118 | 0.122 |
| e | 0.65 BSC | | | 0.026 BSC | | |
| L | 0.40 | 0.55 | 0.70 | 0.016 | 0.021 | 0.028 |
| HE | 4.75 | 4.90 | 5.05 | 0.187 | 0.193 | 0.199 |

SOLDERING FOOTPRINT*

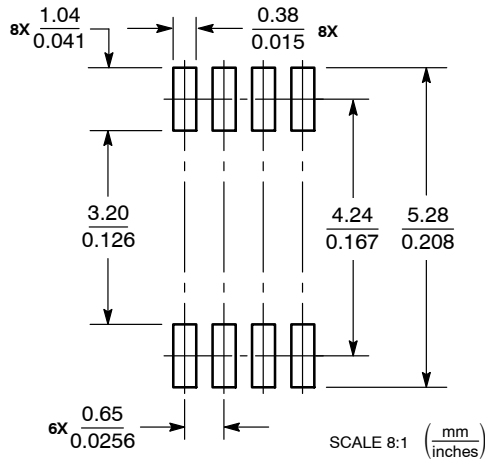

*For additional information on our Pb-Free strategy and soldering details, please download the ON Semiconductor Soldering and Mounting Techniques Reference Manual, SOLDERRM/D.

7WBD3306

PACKAGE DIMENSIONS

TSSOP8, 4.4x3
CASE 948AL-01
ISSUE O

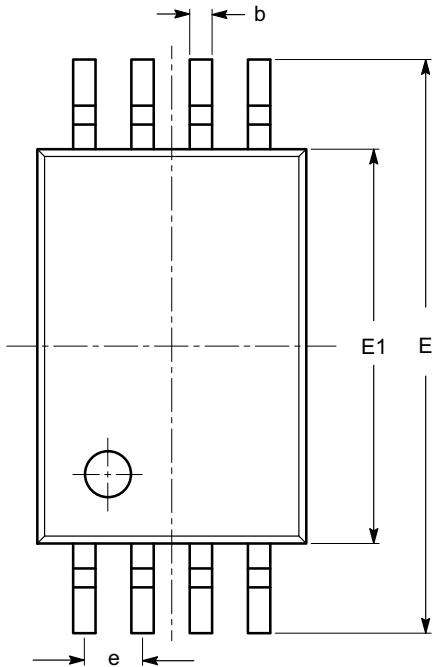

| SYMBOL | MIN | NOM | MAX |
|----------|----------|------|------|
| A | | | 1.20 |
| A1 | 0.05 | | 0.15 |
| A2 | 0.80 | 0.90 | 1.05 |
| b | 0.19 | | 0.30 |
| c | 0.09 | | 0.20 |
| D | 2.90 | 3.00 | 3.10 |
| E | 6.30 | 6.40 | 6.50 |
| E1 | 4.30 | 4.40 | 4.50 |
| e | 0.65 BSC | | |
| L | 1.00 REF | | |
| L1 | 0.50 | 0.60 | 0.75 |
| θ | 0° | | 8° |

TOP VIEW

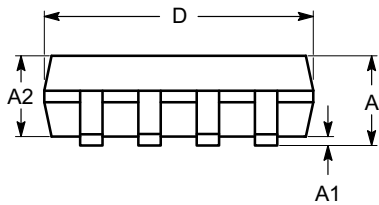

SIDE VIEW

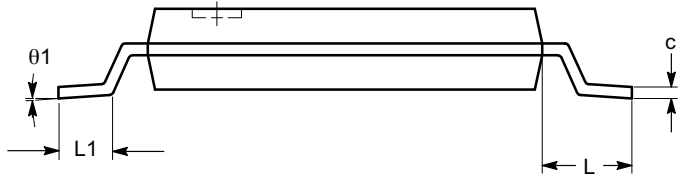

END VIEW

Notes:

- (1) All dimensions are in millimeters. Angles in degrees.
- (2) Complies with JEDEC MO-153.

Micro8 is a trademark of International Rectifier.

ON Semiconductor and  are registered trademarks of Semiconductor Components Industries, LLC (SCILLC). SCILLC reserves the right to make changes without further notice to any products herein. SCILLC makes no warranty, representation or guarantee regarding the suitability of its products for any particular purpose, nor does SCILLC assume any liability arising out of the application or use of any product or circuit, and specifically disclaims any and all liability, including without limitation special, consequential or incidental damages. "Typical" parameters which may be provided in SCILLC data sheets and/or specifications can and do vary in different applications and actual performance may vary over time. All operating parameters, including "Typicals" must be validated for each customer application by customer's technical experts. SCILLC does not convey any license under its patent rights nor the rights of others. SCILLC products are not designed, intended, or authorized for use as components in systems intended for surgical implant into the body, or other applications intended to support or sustain life, or for any other application in which the failure of the SCILLC product could create a situation where personal injury or death may occur. Should Buyer purchase or use SCILLC products for any such unintended or unauthorized application, Buyer shall indemnify and hold SCILLC and its officers, employees, subsidiaries, affiliates, and distributors harmless against all claims, costs, damages, and expenses, and reasonable attorney fees arising out of, directly or indirectly, any claim of personal injury or death associated with such unintended or unauthorized use, even if such claim alleges that SCILLC was negligent regarding the design or manufacture of the part. SCILLC is an Equal Opportunity/Affirmative Action Employer. This literature is subject to all applicable copyright laws and is not for resale in any manner.

PUBLICATION ORDERING INFORMATION

LITERATURE FULFILLMENT:
Literature Distribution Center for ON Semiconductor
P.O. Box 5163, Denver, Colorado 80217 USA
Phone: 303-675-2175 or 800-344-3860 Toll Free USA/Canada
Fax: 303-675-2176 or 800-344-3867 Toll Free USA/Canada
Email: orderlit@onsemi.com

N. American Technical Support: 800-282-9855 Toll Free
USA/Canada
Europe, Middle East and Africa Technical Support:
Phone: 421 33 790 2910
Japan Customer Focus Center
Phone: 81-3-5773-3850

ON Semiconductor Website: www.onsemi.com
Order Literature: <http://www.onsemi.com/orderlit>
For additional information, please contact your local Sales Representative



Компания «ЭлектроПласт» предлагает заключение долгосрочных отношений при поставках импортных электронных компонентов на взаимовыгодных условиях!

Наши преимущества:

- Оперативные поставки широкого спектра электронных компонентов отечественного и импортного производства напрямую от производителей и с крупнейших мировых складов;
- Поставка более 17-ти миллионов наименований электронных компонентов;
- Поставка сложных, дефицитных, либо снятых с производства позиций;
- Оперативные сроки поставки под заказ (от 5 рабочих дней);
- Экспресс доставка в любую точку России;
- Техническая поддержка проекта, помощь в подборе аналогов, поставка прототипов;
- Система менеджмента качества сертифицирована по Международному стандарту ISO 9001;
- Лицензия ФСБ на осуществление работ с использованием сведений, составляющих государственную тайну;
- Поставка специализированных компонентов (Xilinx, Altera, Analog Devices, Intersil, Interpoint, Microsemi, Aeroflex, Peregrine, Syfer, Eurofarad, Texas Instrument, Miteq, Cobham, E2V, MA-COM, Hittite, Mini-Circuits, General Dynamics и др.);

Помимо этого, одним из направлений компании «ЭлектроПласт» является направление «Источники питания». Мы предлагаем Вам помощь Конструкторского отдела:

- Подбор оптимального решения, техническое обоснование при выборе компонента;
- Подбор аналогов;
- Консультации по применению компонента;
- Поставка образцов и прототипов;
- Техническая поддержка проекта;
- Защита от снятия компонента с производства.



Как с нами связаться

Телефон: 8 (812) 309 58 32 (многоканальный)

Факс: 8 (812) 320-02-42

Электронная почта: org@eplast1.ru

Адрес: 198099, г. Санкт-Петербург, ул. Калинина, дом 2, корпус 4, литера А.