



## Si9130 Demonstration Board

### FEATURES

- 5- and 3.3-V Step-Down Synchronous Converters
- Less than 500- $\mu$ A Quiescent Current
- 25- $\mu$ A Shutdown Current
- 5.5- to 30-V Input Operating Range

### DESCRIPTION

The Si9130 Dual-Output Power-Supply Controller for Notebook Computers is a system level integration of two step-down controllers with micropower 5- and 3.3-V linear regulators. The controllers perform high efficiency conversion of the battery pack energy (typically 12 V) or the output of an ac-to-dc wall converter (typically 18 V to 24 V dc) to 5- and 3.3-V system supply voltages. The micropower linear regulator can be used to keep power management and back-up circuitry alive during the shutdown of the step-down converters. The 3.3-V output is adjustable to 3.3 V, 3.45 V or 3.6 V by programming control pins 3.45 ADJ and 3.6 ADJ. Leaving both pins open results in 3.3-V nominal output. Grounding pin 3.45 ADJ while leaving 3.6 ADJ open delivers

3.45-V nominal output. Grounding pin 3.6 ADJ while leaving 3.45 ADJ open delivers 3.6-V nominal output.

On the Demo Board, the Si9130 is configured as a complete system, ready for operation. It takes 5.5- to 30-V in, and produces regulated 5 V at any current from no load to 3 A, and 3.3 V out at any current from no load to 3 A. Included in this document are the Bill of Materials, Demo Board Schematic, and PCB layout.

*The demonstration board layout is available in Gerber file format. Please contact your VISHAY sales representative or distributor for a copy.*

### ORDERING INFORMATION: PART NUMBER Si9130DB

### POWER-UP CHECK LIST—INSTALLED IN VRM MOTHER BOARD SOCKET

1. Start by setting the control switches located in the bottom right corner of the Demo Board. Set the top switch to the left, setting the switching frequency to 200 kHz (to the right is 300 kHz). Set the second switch down to the right, turning the 5-V converter on (to the left is off). Set the third switch down to the right, turning the 3.3-V converter on (to the left is off). Set the bottom switch to the right, allowing the PWM to operate (to the left is shutdown).
2. Attach an electronic load set in resistive mode to the 3.3-V output pins. Set the current to 100 mA. Alternatively, you can use a resistor of value 33  $\Omega$ , 1 W.
3. Attach an electronic load set in resistive mode to the 5-V output pins. Set the current to 100 mA. Alternatively, you can use a resistor of value 50  $\Omega$ , 1 W.
4. Attach a 10-V supply and ground to the pins on the top side of the board. It is best to use a separate wire from the supply's ground to each of the Demo Board's ground pins, because of the high currents at low input voltages.
5. Take an oscilloscope probe, and place the ground on the 5-V GND pin, and the probe on the 5-V pin. Set the vertical scale for this channel at ac coupled at 50 mV/div. Take a second probe, and place the ground on the 5-V GND pin, and the probe on pin 17 (LX<sub>5</sub>) of the Si9130. Set this channel at dc coupled 2 V/div. Set the time base at 200  $\mu$ sec/div.
6. Leave the probes in place. Change the scale on the second probe (the one attached to pin 17) to 10 V/div, and the time base to 500 nsec/div. Set the 5-V output current on the electronic load to 1 A. Set the input power supply to 16 V. Alternatively, *first turn off the input power supply*, and replace the 50-W resistor with a 5- $\Omega$ , 10-W resistor, and then turn the input power supply back on, setting it to 16 V.
7. This step should be performed only if an electronic load is being used. Set the input voltage to 15 V. Remove the second probe (the one attached to pin 17 of the Si9130), or turn off the channel displaying it. Place a current probe around the wire leading from the 5-V output to the electronic load, and set the oscilloscope and amplifier so that it will display approximately 2 A/div. Set the oscilloscope time base back to 200  $\mu$ sec/div. Set the 3.3-V electronic load to have a constant 1-A load. Now set up the 5-V electronic load so that it cycles between 100 mA and 3 A at approximately 1 kHz (1 msec period).
8. This step should be performed only if an electronic load is being used. Set the 5-V electronic load back to a constant 1-A current. Remove the voltage probe from the 5-V output. Move the ground of the probe onto the GND pin of the 3.3-V output, and the probe onto the 3.3-V output pin. Remove the current probe from the 5-V output wire, and place it around the wire leading from the 3.3-V output to the electronic load. Now set up the 3.3-V electronic load so that it cycles between 100 mA and 3 A at approximately 1 kHz (1 msec period).

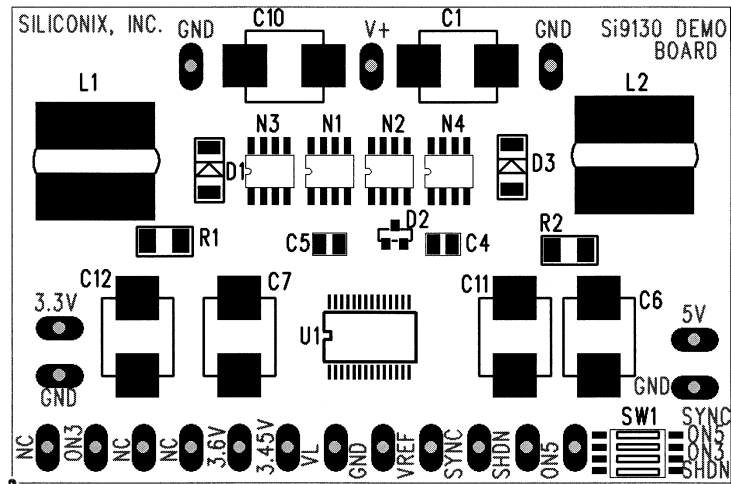

FIGURE 1. Top Silkscreen

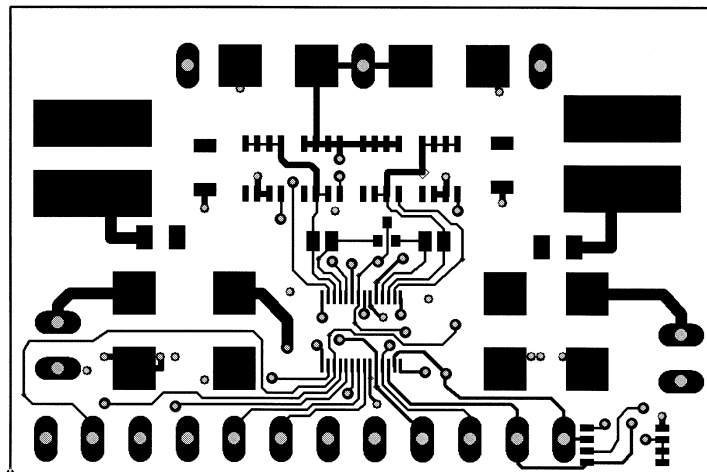

FIGURE 2. Top Layer

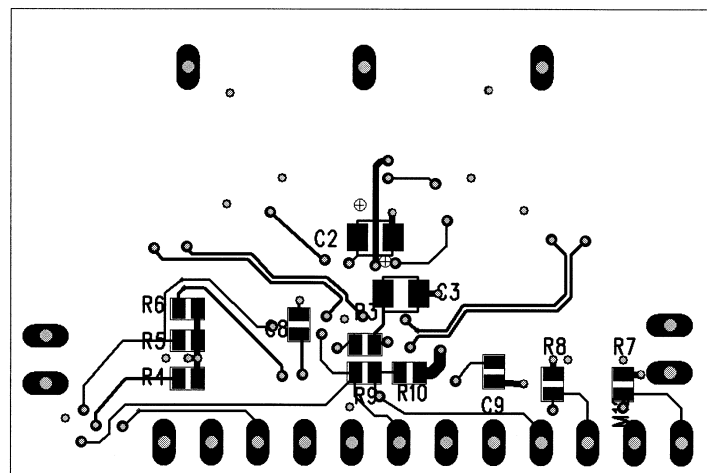
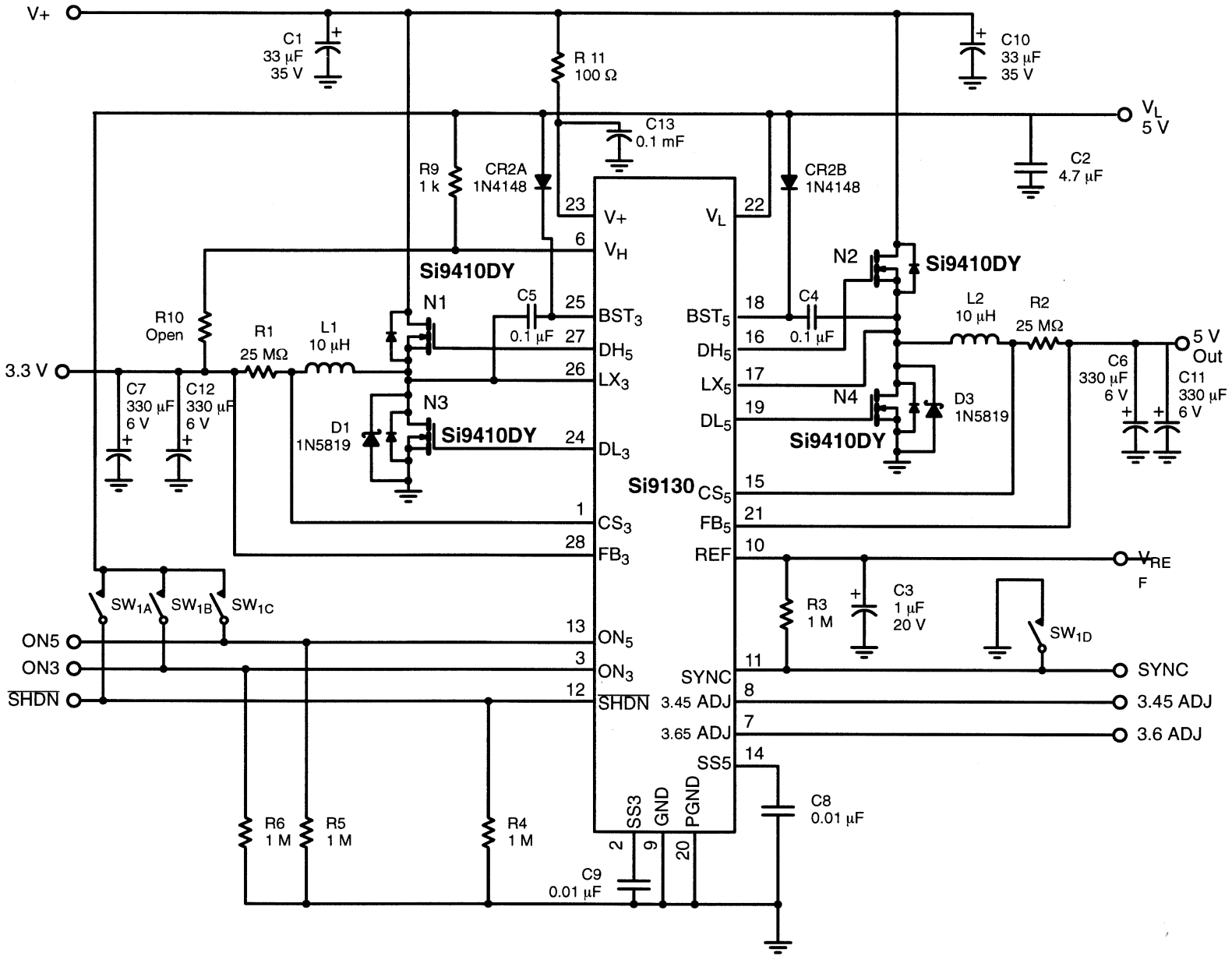

FIGURE 3. Bottom Layer



Si9130DB APPLICATION CIRCUIT





<b>BILL OF MATERIAL FOR Si9130 DUAL-OUTPUT POWER SUPPLY</b>						
<b>Part</b>	<b>Used</b>	<b>Reference Designators</b>	<b>Part Type</b>	<b>Description/Part Number</b>	<b>Pattern</b>	<b>Manufacturer</b>
1	1	U1	Si9130	D-O PWR Supply, Si9130	SSOP-28	Vishay Siliconix
2	2	L1, L2	10 $\mu$ H	Inductor, 10 $\mu$ H, CRD125-100	CDR125-100	Sumida
3	4	N1-N4	Si9410DY	N-Channel MOSFET, Si9410DY	SO-8	Vishay Siliconix
4	1	SW1	SPST	SW-SPST	DIP-4	Multi-Source
5	2	D1, D3	1N5819	Diode, 1N5819	SOD-87	Nikon
6	1	CR2	CMPD2836	Diode, CMPD2836	SOT-23	Central Semiconductor
7	2	R1, R2	0.025 $\Omega$ , 1%	Resistor, LR2010-01-R025F	2010	IRC
8	6	R3-R6	1 M $\Omega$	Resistor, CRCW0805105JRT1	0805	Vishay Dale
9	1	R9	1 k $\Omega$	Resistor, CRCW0805102JRT1	0805	Vishay Dale
10	1	R10	Open	Resistor, (Open)	0805	Multi-Source
11	1	R11	100 $\Omega$	Resistor, CRCW0805101JRT1	0805	Vishay Dale
12	2	C1, C10	33 $\mu$ F, 35 V	Capacitor, Tantalum, 595D336X0035SR	R	Vishay Sprague
13	1	C2	4.7 $\mu$ F, 6 V	Capacitor, Ceramic, 1206YG475ZAT	1206	AVX
14	2	C3	1 $\mu$ F, 20 V	Capacitor, Tantalum, TAJA105M025	A	AVX
15	2	C4, C5	0.1 $\mu$ F, 16 V	Capacitor, VJ0805Y104KXXAT	0805	Vishay Vitramon
16	1	C6, C7, C11, C12	330 $\mu$ F, 6 V	Capacitor, Tantalum, TPSE337M006R0100	E	AVX
17	2	C8, C9	0.01 $\mu$ F, 16 V	Capacitor, VJ0805Y103KXXAT	0805	Vishay Vitramon
18	1	C13	0.1 $\mu$ F, 35 V	Capacitor, VJ0805Y104KXAAT	0805	Vishay Vitramon



Компания «ЭлектроПласт» предлагает заключение долгосрочных отношений при поставках импортных электронных компонентов на взаимовыгодных условиях!

Наши преимущества:

- Оперативные поставки широкого спектра электронных компонентов отечественного и импортного производства напрямую от производителей и с крупнейших мировых складов;
- Поставка более 17-ти миллионов наименований электронных компонентов;
- Поставка сложных, дефицитных, либо снятых с производства позиций;
- Оперативные сроки поставки под заказ (от 5 рабочих дней);
- Экспресс доставка в любую точку России;
- Техническая поддержка проекта, помощь в подборе аналогов, поставка прототипов;
- Система менеджмента качества сертифицирована по Международному стандарту ISO 9001;
- Лицензия ФСБ на осуществление работ с использованием сведений, составляющих государственную тайну;
- Поставка специализированных компонентов (Xilinx, Altera, Analog Devices, Intersil, Interpoint, Microsemi, Aeroflex, Peregrine, Syfer, Eurofarad, Texas Instrument, Miteq, Cobham, E2V, MA-COM, Hittite, Mini-Circuits, General Dynamics и др.);

Помимо этого, одним из направлений компании «ЭлектроПласт» является направление «Источники питания». Мы предлагаем Вам помощь Конструкторского отдела:

- Подбор оптимального решения, техническое обоснование при выборе компонента;
- Подбор аналогов;
- Консультации по применению компонента;
- Поставка образцов и прототипов;
- Техническая поддержка проекта;
- Защита от снятия компонента с производства.



#### Как с нами связаться

**Телефон:** 8 (812) 309 58 32 (многоканальный)

**Факс:** 8 (812) 320-02-42

**Электронная почта:** [org@eplast1.ru](mailto:org@eplast1.ru)

**Адрес:** 198099, г. Санкт-Петербург, ул. Калинина, дом 2, корпус 4, литера А.