

# VSC8501

## Single Port GbE Copper PHY with Synchronous Ethernet and RGMII/GMII Interface

Low-power PHY supports IEEE 802.3az Energy Efficient Ethernet.

The VSC8501 device is designed for space-constrained 10/100/1000BASE-T applications. It features integrated line-side termination to conserve board space, to lower EMI, and to improve system performance. To further reduce system complexity, component count, and system cost, the VSC8501 device can operate from a single 3.3 V supply using integrated voltage regulators that provide the necessary 1.0 V and 2.5 V rails for operation. Additionally, integrated RGMII timing compensation eliminates the need for on-board delay lines.

The VSC8501 device includes Microsemi's EcoEthernet™ 2.0 technology that supports Energy Efficient Ethernet and power saving features to reduce power based on link state and cable reach. The device optimizes power consumption in all link operating speeds and features Wake-on-LAN (WOL) power management using magic packets.

The VSC8501 device also includes fast link failure indication for high-availability networks. Fast link failure indication identifies the onset of a link failure in less than 1 ms typical to go beyond the IEEE 802.3 standard requirement of 750 ms  $\pm$  10 ms (link master).

Synchronous Ethernet and Ring Resiliency™ are supported. The device has two recovered clock outputs for Synchronous Ethernet applications. Programmable clock squelch control is included to inhibit undesirable clocks from propagating and to help prevent timing loops. Ring Resiliency allows a PHY port to switch between master and slave timing references with no link drop in 1000BASE-T mode.

### Highlights

- EcoEthernet™ 2.0, the gold standard for Energy Efficient Ethernet (EEE)
- Wake-on-LAN (WOL)
- Fast link failure indication
- Synchronous Ethernet support
- Dual recovered clocks for timing reference
- Ring Resiliency™
- Integrated voltage regulator
- Pin compatible with VSC8502

### Applications

- IoT applications such as digital signage, eHealth, and industrial grade switches
- Consumer electronics such as CPE, UHDTV, media servers, NAS, and gaming consoles
- Wireless backhaul
- Small cells, femtocells

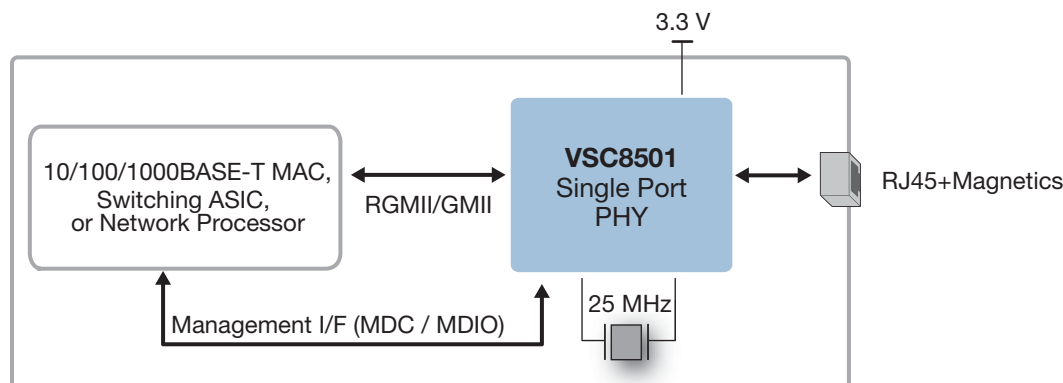

# VSC8501

## Single Port GbE Copper PHY with Synchronous Ethernet and RGMII/GMII Interface

### Superior PHY and Interface Technology

- Integrated 10/100/1000BASE-T Ethernet copper transceiver (IEEE 802.3ab compliant) with VeriPHY™ cable diagnostics software
- Patented line driver with low EMI voltage mode and integrated line-side termination resistors
- Wake-on-LAN using magic packets
- HP Auto-MDIX and manual MDI/MDIX support
- Jumbo frame support up to 16 kilobytes with programmable synchronization FIFOs

### Synchronous Ethernet Support

- Recovered clock outputs with programmable clock squelch control and fast link failure indication (<1 ms typical) for ITU-T G.8261/Y.1361 compliant Synchronous Ethernet (SyncE) application
- 1000BASE-T Ring Resiliency to switch between master and slave timing without dropping link
- Clock output squelch to inhibit clocks during auto-negotiation and no link status

### Best-in-Class Power Consumption

- EcoEthernet™ 2.0 green energy efficiency with ActiPHY™, PerfectReach™, and IEEE 802.3az Energy Efficient Ethernet
- Fully optimized power consumption for all link speeds
- Clause 45 registers to support IEEE 802.3az Energy Efficient Ethernet and IEEE 802.3bf

### Key Specifications

- Compliant with IEEE 802.3 (10BASE-T, 100BASE-TX, and 1000BASE-T)
- Supports GMII
- Supports RGMII version 1.3, and 2.5 V and 3.3 V CMOS for RGMII version 2.0
- Supports IEEE 1149.1 JTAG boundary scan
- Devices support operating temperatures of -40 °C ambient to 125 °C junction or 0 °C ambient to 125 °C junction
- Optionally reports if a link partner is requesting inline Power over Ethernet (PoE or PoE+)
- Available in 12 mm × 12 mm, 135-pin multi-row QFN package

### Related Products

Visit [www.microsemi.com](http://www.microsemi.com) for information about these related products:

- VSC8502
- VSC8514



**Microsemi**

**Microsemi Corporate Headquarters**  
One Enterprise, Aliso Viejo, CA 92656 USA  
Within the USA: +1 (800) 713-4113  
Outside the USA: +1 (949) 380-6100  
Sales: +1 (949) 380-6136  
Fax: +1 (949) 215-4996  
email: [sales.support@microsemi.com](mailto:sales.support@microsemi.com)  
[www.microsemi.com](http://www.microsemi.com)

Microsemi Corporation (Nasdaq: MSCC) offers a comprehensive portfolio of semiconductor and system solutions for communications, defense and security, aerospace, and industrial markets. Products include high-performance and radiation-hardened analog mixed-signal integrated circuits, FPGAs, SoCs, and ASICs; power management products; timing and synchronization devices and precise time solutions; voice processing devices; RF solutions; discrete components; enterprise storage and communications solutions, security technologies, and scalable anti-tamper products; Ethernet solutions; Power-over-Ethernet ICs and midspans; custom design capabilities and services. Microsemi is headquartered in Aliso Viejo, California, and has approximately 4,800 employees worldwide. Learn more at [www.microsemi.com](http://www.microsemi.com).



Компания «ЭлектроПласт» предлагает заключение долгосрочных отношений при поставках импортных электронных компонентов на взаимовыгодных условиях!

Наши преимущества:

- Оперативные поставки широкого спектра электронных компонентов отечественного и импортного производства напрямую от производителей и с крупнейших мировых складов;
- Поставка более 17-ти миллионов наименований электронных компонентов;
- Поставка сложных, дефицитных, либо снятых с производства позиций;
- Оперативные сроки поставки под заказ (от 5 рабочих дней);
- Экспресс доставка в любую точку России;
- Техническая поддержка проекта, помощь в подборе аналогов, поставка прототипов;
- Система менеджмента качества сертифицирована по Международному стандарту ISO 9001;
- Лицензия ФСБ на осуществление работ с использованием сведений, составляющих государственную тайну;
- Поставка специализированных компонентов (Xilinx, Altera, Analog Devices, Intersil, Interpoint, Microsemi, Aeroflex, Peregrine, Syfer, Eurofarad, Texas Instrument, Miteq, Cobham, E2V, MA-COM, Hittite, Mini-Circuits, General Dynamics и др.);

Помимо этого, одним из направлений компании «ЭлектроПласт» является направление «Источники питания». Мы предлагаем Вам помощь Конструкторского отдела:

- Подбор оптимального решения, техническое обоснование при выборе компонента;
- Подбор аналогов;
- Консультации по применению компонента;
- Поставка образцов и прототипов;
- Техническая поддержка проекта;
- Защита от снятия компонента с производства.



#### Как с нами связаться

**Телефон:** 8 (812) 309 58 32 (многоканальный)

**Факс:** 8 (812) 320-02-42

**Электронная почта:** [org@eplast1.ru](mailto:org@eplast1.ru)

**Адрес:** 198099, г. Санкт-Петербург, ул. Калинина, дом 2, корпус 4, литера А.