

# 3M™ Three-Wall Header

.100" × .100" Latch/Ejector, Straight and Right Angle

3000 Series



- Military (with 3M's 3518 or N3518 polarizing key) and center bump polarization
- Low profile
- Optional ejector latches
- Mounting holes for securing header to board
- Three wall shroud provides design flexibility
- Solder tail and wrap tail options
- Optional polarizing posts available
- Optional high temperature insulator suitable for "no lead" soldering operations
- High temperature option is suitable for reflow soldering using "paste in hole" techniques
- See the Regulatory Information Appendix (RIA) in the "RoHS compliance" section of [www.3Mconnectors.com](http://www.3Mconnectors.com) for compliance information

Date Modified: May 21, 2012

TS-0771-F  
Sheet 1 of 5

## Physical

### Insulator:

Material: Glass Filled Polyester (PBT)  
Glass Filled Polyester (PCT) - High Temp Option

Flammability: UL 94V-0

Color: Gray (PBT), Black (PCT)

### Contact:

Material: Copper Alloy

### Plating:

Underplating: 100 μ" [ 2.54 μm ] Nickel - Overall

Wiping Area: 30 μ" [ 0.76 μm ] Gold

Solder Tails: 200 μ" [ 5.08 μm ] Tin Lead or Matte Tin (See Ordering Information)

Marking: 3M Logo, Part Identification Number and Orientation Triangle

## Electrical

**Current Rating:** 5.00 A, 1 Contact Powered  
3.00 A, 6 Contacts Powered  
1.75 A, All Contacts Powered  
Rating Conditions: EIA-364-070 Method 2, 30°C maximum temperature rise, 20% derated. Reference appropriate 3M Product Specification for detailed current derating curves.

**Insulation Resistance:**  $>1 \times 10^9 \Omega$  at 500 V<sub>DC</sub>

**Withstanding Voltage:** 1000 V<sub>RMS</sub> at Sea Level

## Environmental

**Temperature Rating:** -55°C to +105°C

**Process Rating:** High Temp PCT insulator version: 260°C, per J-STD-020C, single pass  
PBT insulator version: 191°C, maximum insulator temperature, solder wave process only

**Moisture Sensitivity Level:** 1 (per J-STD-020C) High Temp. (PCT) versions only

UL File No.: E68080

**3M**

Electronic Solutions Division  
Interconnect Solutions  
<http://www.3Mconnectors.com>

3M is a trademark of 3M Company.  
For technical, sales or ordering information call  
**800-225-5373**

# 3M™ Three-Wall Header

.100" × .100" Latch/Ejector, Straight and Right Angle

3000 Series

-X0XX  
Header without Latches



-X2XX  
Header with  
Short Ejector/Latch  
for 3M Sockets without  
Strain Relief



-X3XX  
Header with  
Long Ejector/Latch  
for 3M Sockets with  
Strain Relief

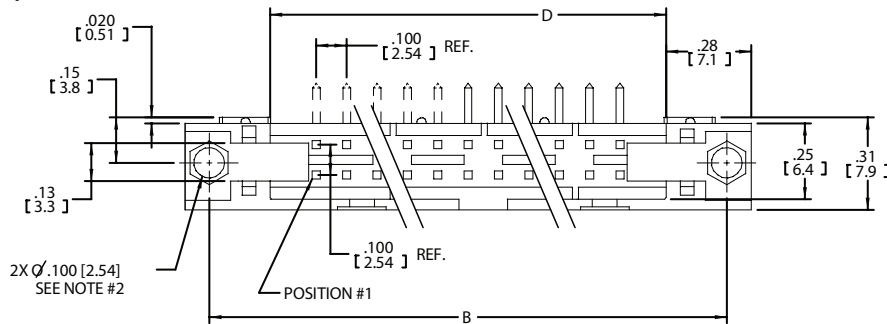
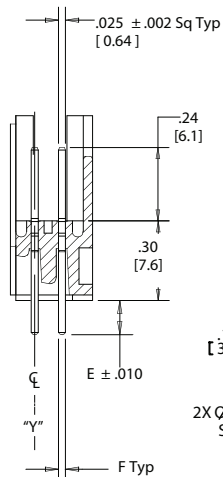

Section A-A  
(Straight)

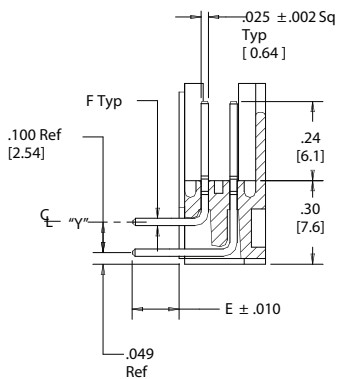

Section B-B  
(Right Angle)

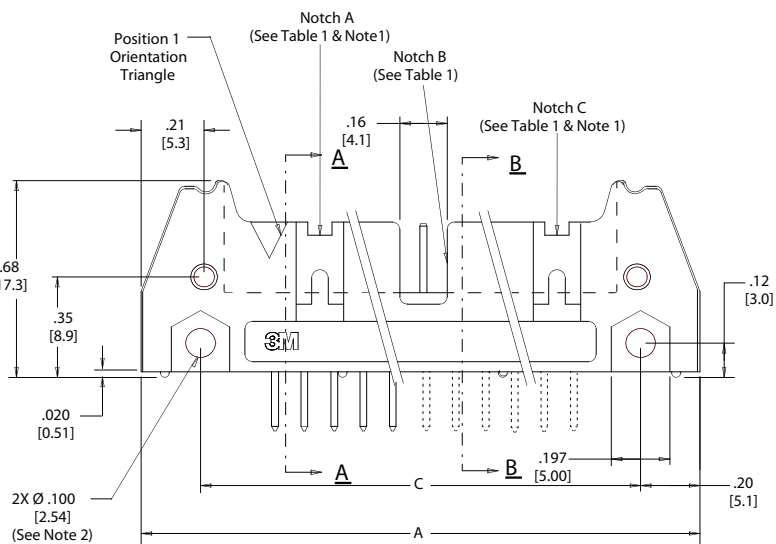

TS-0771-F  
Sheet 2 of 5

# 3M™ Three-Wall Header

.100" × .100" Latch/Ejector, Straight and Right Angle

3000 Series

Table 1						
Pin Qty	3M Part Number	Dimensions				Polarizing Notches
		A	B	C	D	
10	3793	1.26 (32.1)	1.105 (28.07)	0.865 (21.97)	0.71 (18.0)	BC
14	3314	1.46 (37.2)	1.305 (33.15)	1.065 (27.05)	0.91 (23.1)	BC
16	3408	1.56 (39.7)	1.405 (35.69)	1.165 (29.59)	1.01 (25.6)	ABC
20	3428	1.76 (44.8)	1.605 (40.77)	1.365 (34.67)	1.21 (30.7)	ABC
26	3429	2.06 (52.4)	1.905 (48.39)	1.665 (42.29)	1.51 (38.3)	ABC
34	3431	2.46 (62.6)	2.305 (58.55)	2.065 (52.45)	1.91 (48.5)	ABC
40	3432	2.76 (70.2)	2.605 (66.17)	2.365 (60.07)	2.21 (56.1)	ABC
50	3433	3.26 (82.9)	3.105 (78.87)	2.865 (72.77)	2.71 (68.8)	ABC
60	3372	3.76 (95.6)	3.605 (91.57)	3.365 (85.47)	3.21 (81.5)	ABC
64	3764	3.96 (100.7)	3.805 (96.65)	3.565 (90.55)	3.41 (86.6)	ABC

Table 2						
3M Part Number Suffix	Contact Tail	Dimension E	Pin Cross Section			Dimension G
			Dimension F	Diagonals	Corner Radii	
-1XX2 -2XX2	Solder Tail for .062 (1.57) Thick PC Board	.112 (2.84)	.0245 ± .0005 (0.622)	.028 ± .001 (0.71)	.0075 Ref (0.191)	0.035 ± .003 (0.89) (See Note 3)
-1X03 -2X03	Solder Tail for 0.94 (2.39) to .125 (3.18) Thick PC Board	.155 (3.94)	.0245 ± .0005 (0.622)	.028 ± .001 (0.71)	.0075 Ref (0.191)	0.035 ± .003 (0.89)

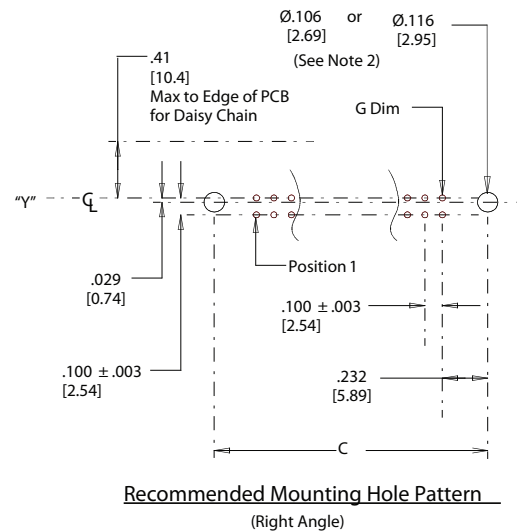
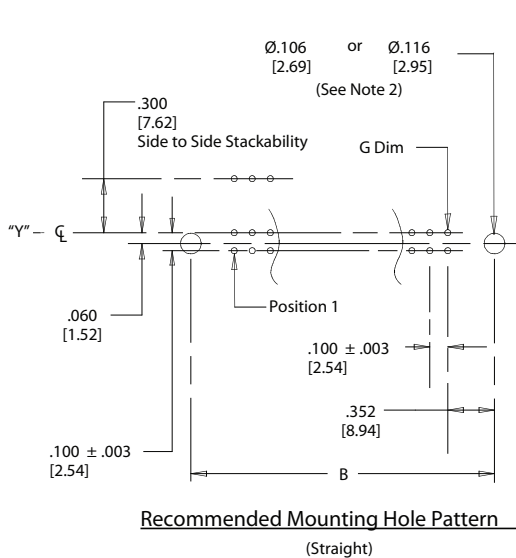

Inch (mm)			
Tolerance Unless Noted			
	.0	.00	.000
Inch	± .1	± .01	± .005

[ ] Dimensions for Reference only

**Notes:**

- Notches A & C will accommodate 3M Polarizing Keys (3M Part #3518 or N3518).
- Accepts Rear and Front mounting hardware:  
Rear Entry: #4-24 thread cutting screw, 3M Part #3341-5, .116 [2.95] dia mounting hole  
Front Entry: (Prior to installation of latch on Straight Versions) #2-56 bolt and nut, 3M Part #3341-6, .106 [2.69] dia mounting hole. See illustrations on page 5.
- The recommended PCB hole size for the kinked tail positions on the .112 solder tail connector is .035 ± .002. Kink is located .05" below bottom surface of plastic. External radius of kink toward part centerline

TS-0771-F  
Sheet 3 of 5

# 3M™ Three-Wall Header

.100" × .100" Latch/Ejector, Straight and Right Angle

3000 Series

## Ordering Information



## Part Customization

This spec sheet details our standard offering.

3M has several capabilities that can provide a part tailored to your specific needs. Ask your 3M sales representative or customer service for more details.

Use of snap-in style latch/ejectors in either short (N3XXX X5XX) or long (N3XXX-X6XX) styles, installed or shipped separately (the -5 & -6 snap-in latches are dimensional and functional equivalents to the -2 & -3 roll pin latches) which are also available separately with roll pins included. Refer to chart below.

If ordering snap-in or roll pin style latches separately, please use the below chart

	Short Latch	Long Latch	Latch Style	Color
Standard Temperature (PBT)	3505-2	3505-3	Roll Pin	Gray
High Temperature (PCT)	N3505-2B	N3505-3B	Roll Pin	Black
High Temperature (PBT)	3505-30	3505-31	Snap-In	Gray
High Temperature (PPA)	N3505-30B	N3505-31B	Snap-In	Black

- Selective pin removal (ATA or other compatibility)
- Wire wrap tails styles

## Kinked Tail (K2 option) positions:

2500 & 3000 Series Shrouded Header					
Total Number of Pins	Number of Tails Kinked	Positions Kinked			
10	4	3	4	7	8
14	4	3	4	11	12
16	4	3	4	13	14
20	4	3	4	17	18
24	4	3	4	21	22
26	4	3	4	23	24
30	4	5	6	25	26
34	4	7	8	27	28
36	4	7	8	27	28
40	4	7	8	33	34
50	4	7	8	43	44
60	4	11	12	49	50
64	4	11	12	53	54

### Kinked Tail Detail:

Kink is located .05" below bottom surface of plastic.  
External radius of kink toward part centerline.

TS-0771-F  
Sheet 4 of 5



Electronic Solutions Division  
Interconnect Solutions  
<http://www.3Mconnectors.com>

3M is a trademark of 3M Company.  
For technical, sales or ordering information call  
**800-225-5373**

# 3M™ Three-Wall Header

.100" × .100" Latch/Ejector, Straight and Right Angle

3000 Series

## Polarizing Post

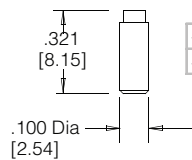

3201-3	PBT	Gray
3201-4	LCP	Black

Note: Insert Post into one mounting hardware hole on bottom of header. Set post to protrude .115" [2.92]

## Polarizing Keys

			Dim A
N3518	LCP	Black	.02
3518	PBT	Gray	.02

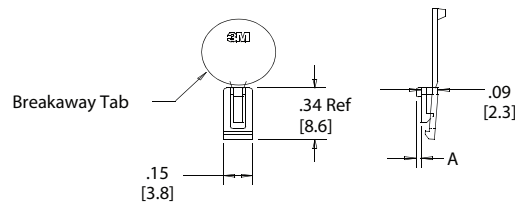

Note: #2216 B/A Scotchweld can be used to adhere keys.

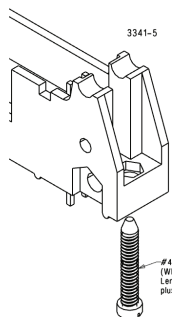

#4-24 Type BT Self Threading Screw  
(When using Latches, Maximum Length of screw is .250 inch plus thickness of the board.  
TORQUE IN THIS DIRECTION IS 7-9 INCH LBS.

#4-24 Type BT Self Threading Screw  
(When using Latches, Maximum Length of screw is .250 inch plus thickness of the board.  
TORQUE IN THIS DIRECTION IS 5-7 INCH LBS.

## Mounting Hardware

3341-5  
(Installed from bottom of board)

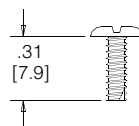

Panhead Thread Cutting Screw:  
#4-24 X 5/16"  
Type: USA Std BT, Federal BG

3341-6  
(Must be inserted prior to latch or vertical headers)

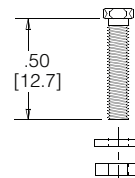

Hex Head Bolt, Nut and Was  
Bolt - #2-56 X 1/2"

3341-5 & 6  
Material - Stainless Steel

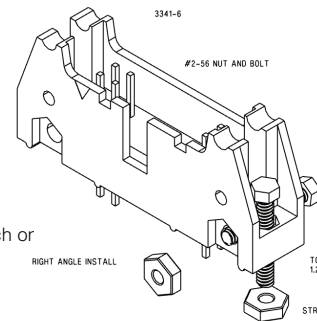

TORQUE:  
1.25 - 3.125 INCH LBS.

TS-0771-F  
Sheet 5 of 5

**Important Notice**

All statements, technical information, and recommendations related to 3M's products are based on information believed to be reliable, but the accuracy or completeness is not guaranteed. Before using this product, you must evaluate it and determine if it is suitable for your intended application. You assume all risks and liability associated with such use. Any statements related to the product which are not contained in 3M's current publications, or any contrary statements contained on your purchase order shall have no force or effect unless expressly agreed upon, in writing, by an authorized officer of 3M.

**Warranty; Limited Remedy; Limited Liability.**

This product will be free from defects in material and manufacture for a period of one (1) year from the time of purchase. **3M MAKES NO OTHER WARRANTIES INCLUDING, BUT NOT LIMITED TO, ANY IMPLIED WARRANTY OF MERCHANTABILITY OR FITNESS FOR A PARTICULAR PURPOSE.** If this product is defective within the warranty period stated above, your exclusive remedy shall be, at 3M's option, to replace or repair the 3M product or refund the purchase price of the 3M product. **Except where prohibited by law, 3M will not be liable for any indirect, special, incidental or consequential loss or damage arising from this 3M product, regardless of the legal theory asserted.**

**3M Electronics Solutions Division**

6801 River Place Blvd.  
Austin, TX 78726-9000  
U.S.A.  
1-800-225-5373  
[www.3Mconnectors.com](http://www.3Mconnectors.com)

Please recycle. Printed in USA.  
© 3M 2012. All rights reserved.  
RIA-2217B-E

3M is a trademark of 3M Company.



Компания «ЭлектроПласт» предлагает заключение долгосрочных отношений при поставках импортных электронных компонентов на взаимовыгодных условиях!

Наши преимущества:

- Оперативные поставки широкого спектра электронных компонентов отечественного и импортного производства напрямую от производителей и с крупнейших мировых складов;
- Поставка более 17-ти миллионов наименований электронных компонентов;
- Поставка сложных, дефицитных, либо снятых с производства позиций;
- Оперативные сроки поставки под заказ (от 5 рабочих дней);
- Экспресс доставка в любую точку России;
- Техническая поддержка проекта, помощь в подборе аналогов, поставка прототипов;
- Система менеджмента качества сертифицирована по Международному стандарту ISO 9001;
- Лицензия ФСБ на осуществление работ с использованием сведений, составляющих государственную тайну;
- Поставка специализированных компонентов (Xilinx, Altera, Analog Devices, Intersil, Interpoint, Microsemi, Aeroflex, Peregrine, Syfer, Eurofarad, Texas Instrument, Miteq, Cobham, E2V, MA-COM, Hittite, Mini-Circuits, General Dynamics и др.);

Помимо этого, одним из направлений компании «ЭлектроПласт» является направление «Источники питания». Мы предлагаем Вам помощь Конструкторского отдела:

- Подбор оптимального решения, техническое обоснование при выборе компонента;
- Подбор аналогов;
- Консультации по применению компонента;
- Поставка образцов и прототипов;
- Техническая поддержка проекта;
- Защита от снятия компонента с производства.



#### Как с нами связаться

**Телефон:** 8 (812) 309 58 32 (многоканальный)

**Факс:** 8 (812) 320-02-42

**Электронная почта:** [org@eplast1.ru](mailto:org@eplast1.ru)

**Адрес:** 198099, г. Санкт-Петербург, ул. Калинина, дом 2, корпус 4, литера А.