

GENERAL DESCRIPTION

The 844S2416 is a 17 output, dual-PLL frequency synthesizer optimized to generate a variety of clocks for Ethernet, USB and other interfaces. Using a 25MHz 18pF parallel resonant crystal, the device will generate 24MHz, 25MHz, 100MHz and 200MHz clocks with mixed HCSL and LVCMOS/LVTTL levels.

The 844S2416 is packaged in a 56-pin VFQFN package that is optimum for applications with space limitations.

FEATURES

- Two LVCMOS/LVTTL single-ended outputs at 24MHz
- Twelve LVCMOS/LVTTL single-ended outputs at 25MHz
- Two differential HCSL output pairs at 100MHz
- One differential HCSL output pair at 100MHz or 200MHz
- Crystal oscillator interface: 25MHz
- PLL1 – VCO: 2.4GHz
- PLL2 – VCO range: 1.8GHz - 2.2GHz
±10% frequency margining in 1.25% steps
Selectable spread spectrum – downspread at -0.5%
- I²C control interface with address configuration pin and with default loading on release of active low reset
- 3.3V supply voltage
- -40°C to 85°C ambient operating temperature
- Available in lead-free (RoHS 6) package

PIN ASSIGNMENT

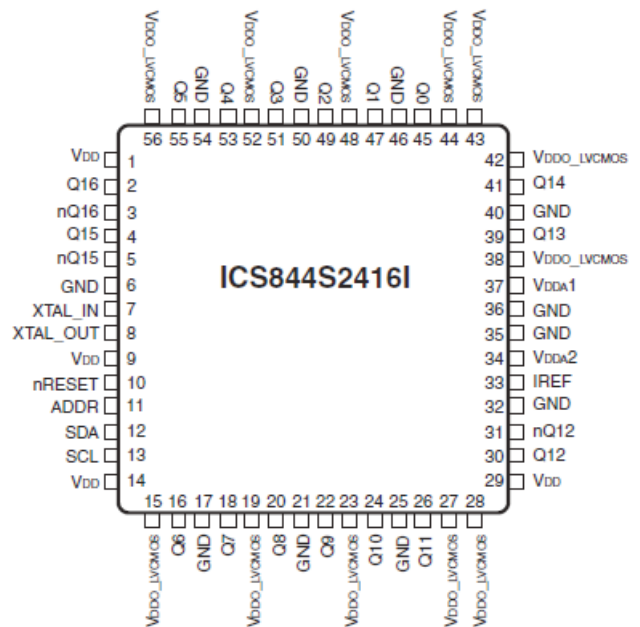

56-Lead VFQFN

8mm x 8mm x 0.925mm package body

K Package

Top View

BLOCK DIAGRAM

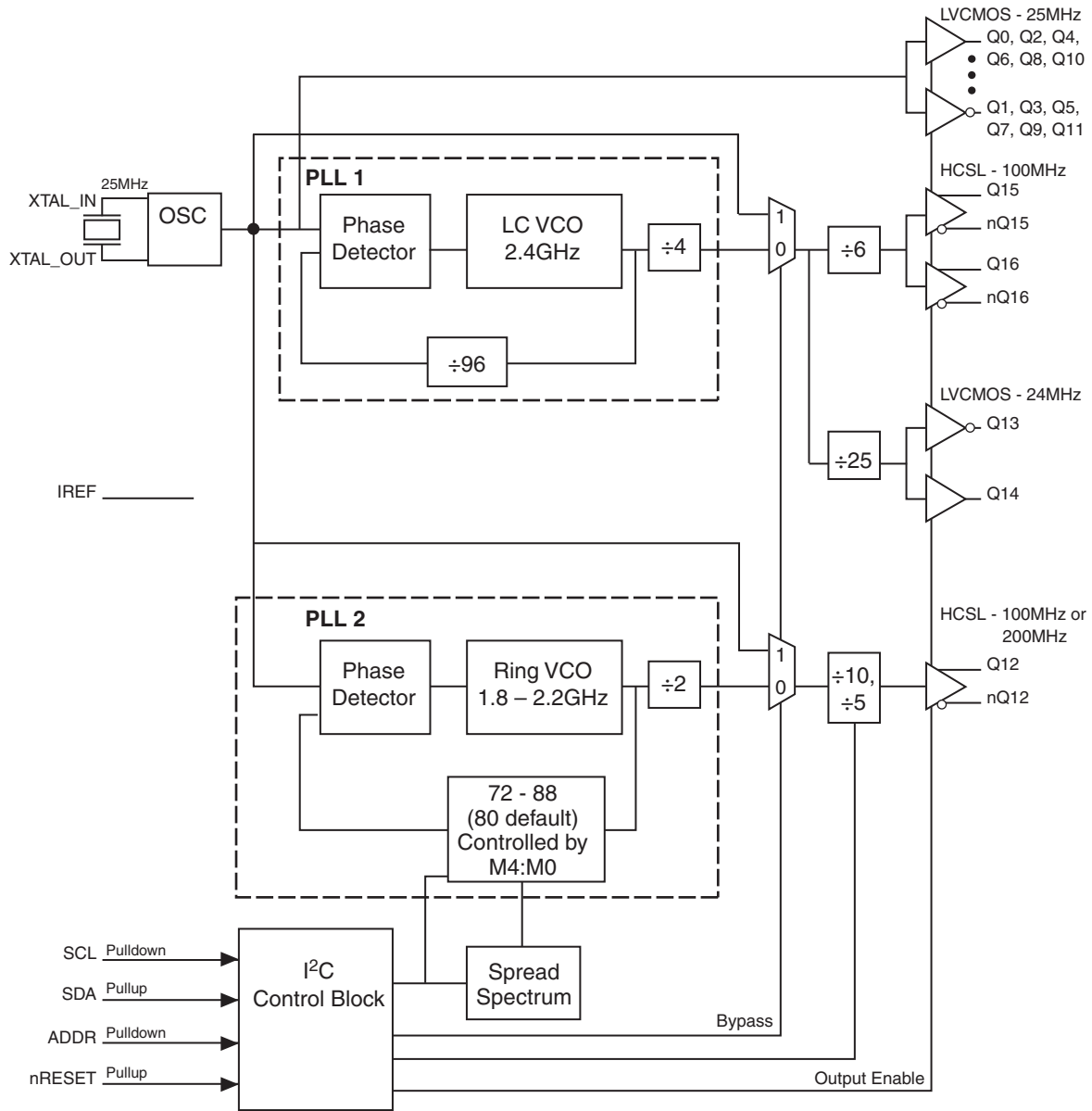

TABLE 1. PIN DESCRIPTIONS

Number	Name	Type		Description
1, 9, 14, 29	V _{DD}	Power		Core supply pins.
2, 3	Q16, nQ16	Output		Differential clock outputs. HCSL interface levels.
4, 5	Q15, nQ15	Output		Differential clock outputs. HCSL interface levels.
6, 17, 21, 25, 32, 35, 36, 40, 46, 50, 54	GND	Power		Power supply ground.
7, 8	XTAL_IN, XTAL_OUT	Input		Crystal oscillator interface. XTAL_IN is the input. XTAL_OUT is the output.
10	nRESET	Input	Pullup	nRESET signal resets all the output dividers, default setting of PLL1 and I ² C registers. nRESET signal also puts Q0:Q11 outputs in the Hi-Z state for power sequencing. LVCMOS/LVTTL interface levels.
11	ADDR	Input	Pulldown	Serial address select pin. LVCMOS/ LVTTL interface levels.
12	SDA	I/O	Pullup	I ² C serial data input. LVCMOS/ LVTTL interface levels.
13	SCL	Input	Pulldown	I ² C serial clock input. LVCMOS/ LVTTL interface levels.
15, 19, 23, 27, 28, 38, 42, 43, 44, 48, 52, 56	V _{DDO_LVCMOS}	Power		Output supply pins for LVCMOS/LVTTL outputs.
16, 20, 24, 41, 45, 49, 53	Q6, Q8, Q10, Q14, Q0, Q2, Q4	Output		Single-ended non-inverted clock outputs. LVCMOS/LVTTL interface levels.
18, 22, 26, 39, 47, 51, 55	Q7, Q9, Q11, Q13, Q1, Q3, Q5			Single-ended inverted clock outputs. LVCMOS/LVTTL interface levels.
30, 31	Q12, nQ12	Output		Differential clock outputs. HCSL interface levels.
33	IREF			HCSL current reference resistor output. An external fixed precision resistor (475Ω) from this output to ground provides a reference current used for differential current mode outputs Q12/nQ12, Q15/nQ15 and Q16/nQ16.
34	V _{DDA2}	Power		Analog supply pin for PLL2.
37	V _{DDA1}	Power		Analog supply pin for PLL1.

NOTE: *Pullup* and *Pulldown* refer to internal input resistors. See Table 5, Pin Characteristics, for typical values.

TABLE 2. PIN CHARACTERISTICS

Symbol	Parameter	Test Conditions	Minimum	Typical	Maximum	Units
C _{IN}	Input Capacitance			2		pF
R _{PULLUP}	Input Pullup Resistor			51		kΩ
R _{PULLDOWN}	Input Pulldown Resistor			51		kΩ
R _{OUT}	Output Impedance	Q0:Q11, Q13:Q14		21		Ω

The 844S2416 uses an industry standard I²C interface to control the programming of the output enables of every output, the feedback divider value for PLL2, spread spectrum enabling for PLL2, and

output divider clock source selection. The I²C control registers and default settings are shown below:

Output Enable Control Bits:	Q0:Q11, Q13:Q14, Q15:Q16/nQ15:nQ16 outputs are enabled, Q12/nQ12 is disabled
PLL2 M Divider Value:	80
SSC:	Off
BYPASS:	Output divider clock source is the PLL
Q12 Frequency (f):	200MHz

I²C REGISTER SUMMARY

Data Byte 0

Control Bit	Q16_EN	Q15_EN	Q14_EN	Q13_EN	Q12_EN	Q11_EN	Q10_EN	Q9_EN
Power-up Default Value	1	1	1	1	0	1	1	1

Data Byte 1

Control Bit	Q8_EN	Q7_EN	Q6_EN	Q5_EN	Q4_EN	Q3_EN	Q2_EN	Q1_EN
Power-up Default Value	1	1	1	1	1	1	1	1

Data Byte 2

Control Bit	Q0_EN	M4	M3	M2	M1	M0	SSC	BYPASS
Power-up Default Value	1	0	1	0	0	0	0	0

Data Byte 3

Control Bit	f (Q12)	Revision	Reserved	Reserved	Reserved	Reserved	Reserved	Reserved
Power-up Default Value	0	1	X	X	X	X	X	X

FUNCTION TABLES

TABLE 3A. OUTPUT STATES FUNCTION TABLE

Outputs	Output Levels	Disable State
Q0:Q11	LVC MOS	Hi-Z
Q12/nQ12	HCSL	Hi-Z
Q13:Q14	LVC MOS	Hi-Z
Q15/nQ15	HCSL	Hi-Z
Q16/nQ16	HCSL	Hi-Z

TABLE 3B. PLL2 FEEDBACK DIVIDER FUNCTION TABLE (Q12/nQ12, ± 10 MODE)

VCO Frequency (MHz)	Q12/nQ12 Frequency (MHz)	Feedback Divide	M4	M3	M2	M1	M0
1800	90	72	0	0	0	0	0
1825	91.25	73	0	0	0	0	1
1850	92.5	74	0	0	0	1	0
1875	93.75	75	0	0	0	1	1
1900	95	76	0	0	1	0	0
1925	96.25	77	0	0	1	0	1
1950	97.5	78	0	0	1	1	0
1975	98.75	79	0	0	1	1	1
2000	100	80 (default)	0	1	0	0	0
2025	101.25	81	0	1	0	0	1
2050	102.5	82	0	1	0	1	0
2075	103.75	83	0	1	0	1	1
2100	105	84	0	1	1	0	0
2125	106.25	85	0	1	1	0	1
2150	107.5	86	0	1	1	1	0
2175	108.75	87	0	1	1	1	1
2200	110	88	1	0	0	0	0
Not Used	Not Used	Not Used	1	0	0	0	1
			• • •				
			1	1	1	1	1

TABLE 3C. PLL2, SSC MODE FUNCTION TABLE

Register Bit	SS Mode
SSC	
0	
1	

TABLE 3D. BYPASS CLOCK SELECTION TABLE

Register Bit	Clock Source
Bypass	
0 (default)	
1	

TABLE 3E. Q12 FREQUENCY SELECTION TABLE

Register Bit	Output Frequency
Q12 Frequency	
0 (default)	200MHz
1	100MHz

TABLE 3F. REVISION DESCRIPTION TABLE

Register Bit	Part Revision
Revision	
0	Revision B
1	Revision C

I²C ADDRESSING

The 844S2416 can be set to decode one of two addresses to minimize the chance of address conflict on the I²C bus. The address that

ADDR = 0

ADDR = 0 Default							
Bit 7	Bit 6	Bit 5	Bit 4	Bit 3	Bit 2	Bit 1	Bit 0
1	0	0	1	1	0	0	R/W

is decoded is controlled by the setting of the ADDR pin as shown below.

ADDR = 1

ADDR = 1							
Bit 7	Bit 6	Bit 5	Bit 4	Bit 3	Bit 2	Bit 1	Bit 0
1	0	0	1	1	1	0	R/W

I²C INTERFACE - PROTOCOL

The 844S2416 is a slave-only device and uses the standard I²C protocol as shown in the below diagrams. The maximum SCL

frequency is greater than 10MHz which is more than sufficient for standard I²C clock speeds.

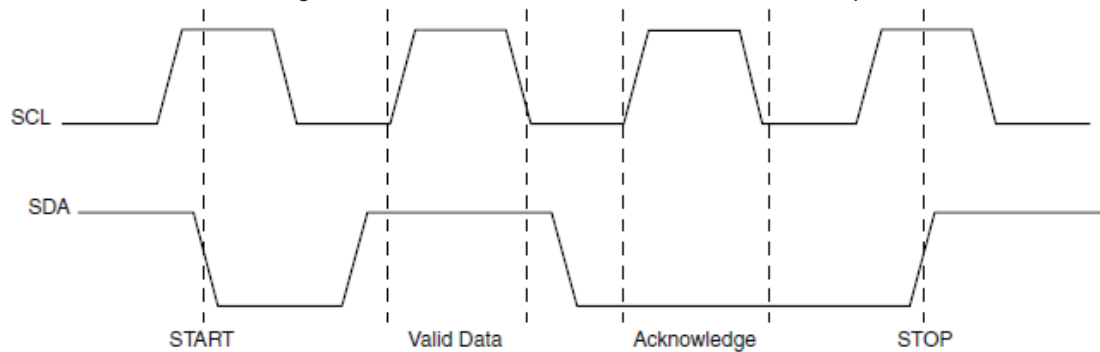

START (ST) – defined as high-to-low transition on SDA while holding SCL HIGH.

DATA - Between START and STOP cycles, SDA is synchronous with SCL. Data may change only when SCL is LOW and must be stable when SCL is HIGH.

ACKNOWLEDGE (AK) – SDA is driven LOW before the SCL rising edge and held LOW until the SCL falling edge.

STOP (SP) – defined as low-to-high transition on SDA while holding SCL HIGH.

I²C INTERFACE - A WRITE EXAMPLE

A serial transfer to the 844S2416 always consists of an address cycle followed by 4 data bytes. Once the 4 data bytes are loaded and the master generates a stop condition, the values in the serial

control register are latched into the M divider and control bits, and the device will move to the new frequency and any changes to the state of the control bits will take effect.

ST	Slave Address: 7 Bits							R/W	AK
1 Bit	Refer to I ² C Addressing section for address choices based on ADDR pin setting							1 Bit	1 Bit
Data Byte 0: 8 Bits								AK	
Q16_EN	Q15_EN	Q14_EN	Q13_EN	Q12_EN	Q11_EN	Q10_EN	Q9_EN	1 Bit	
Data Byte 1: 8 Bits								AK	
Q8_EN	Q7_EN	Q6_EN	Q5_EN	Q4_EN	Q3_EN	Q2_EN	Q1_EN	1 Bit	
Data Byte 2: 8 Bits								AK	
Q0_EN	M4	M3	M2	M1	M0	SSC	BYPASS	1 Bit	
Data Byte 3: 8 Bits								AK	SP
f (Q12)	Revision	Reserved	Reserved	Reserved	Reserved	Reserved	Reserved	1 Bit	1 Bit

↑
Data Byte values latched into control registers here.

ABSOLUTE MAXIMUM RATINGS

Supply Voltage, V_{DD}	4.6V
Inputs, V_I	-0.5V to $V_{DD} + 0.5V$
Outputs, V_O (LVCMOS & HCSSL)	-0.5V to $V_{DDO_LVCMOS} + 0.5V$
Package Thermal Impedance, θ_{JA}	31.4°C/W (0 mps)
Storage Temperature, T_{STG}	-65°C to 150°C

NOTE: Stresses beyond those listed under Absolute Maximum Ratings may cause permanent damage to the device. These ratings are stress specifications only. Functional operation of product at these conditions or any conditions beyond those listed in the *DC Characteristics* or *AC Characteristics* is not implied. Exposure to absolute maximum rating conditions for extended periods may affect product reliability.

TABLE 4A. POWER SUPPLY DC CHARACTERISTICS, $V_{DD} = V_{DDO_LVCMOS} = 3.3V \pm 5\%$, $T_A = -40^\circ\text{C}$ TO 85°C

Symbol	Parameter	Test Conditions	Minimum	Typical	Maximum	Units
V_{DD}	Core Supply Voltage		3.135	3.3	3.465	V
V_{DDA1}, V_{DDA2}	Analog Supply Voltage		$V_{DD} - 0.31$	3.3	V_{DD}	V
V_{DDO_LVCMOS}	Output Supply Voltage		3.135	3.3	3.465	V
I_{DD}	Power Supply Current	No Load			170	mA
I_{DDA1}	PLL1 Analog Supply Current				9	mA
I_{DDA2}	PLL2 Analog Supply Current				22	mA
I_{DDO_LVCMOS}	Output Supply Current	No Load Q[0:11] at 25MHz, Q13, Q14 at 24MHz			16	mA

TABLE 4B. LVCMOS / LVTTTL DC CHARACTERISTICS, $V_{DD} = V_{DDO_LVCMOS} = 3.3V \pm 5\%$, $T_A = -40^\circ\text{C}$ TO 85°C

Symbol	Parameter	Test Conditions	Minimum	Typical	Maximum	Units
V_{IH}	Input High Voltage		2		$V_{DD} + 0.3$	V
V_{IL}	Input Low Voltage		-0.3		0.8	V
I_{IH}	Input High Current	ADDR, SCL	$V_{DD} = V_{IN} = 3.465V$		150	μA
		SDA, nRESET	$V_{DD} = V_{IN} = 3.465V$		10	μA
I_{IL}	Input Low Current	ADDR, SCL	$V_{DD} = 3.465V, V_{IN} = 0V$	-10		μA
		SDA, nRESET	$V_{DD} = 3.465V, V_{IN} = 0V$	-150		μA
V_{OH}	Output High Voltage	$I_{OH} = -12\text{mA}$	2.6			V
V_{OL}	Output Low Voltage	$I_{OL} = 12\text{mA}$			0.5	V

TABLE 5. CRYSTAL CHARACTERISTICS

Parameter	Test Conditions	Minimum	Typical	Maximum	Units
Mode of Oscillation		Fundamental			
Frequency			25		MHz
Equivalent Series Resistance (ESR)				50	Ω
Shunt Capacitance				7	pF
Drive Level				100	μW

TABLE 6. AC CHARACTERISTICS, $V_{DD} = V_{DDO_LVCMOS} = 3.3V \pm 5\%$, $T_A = -40^\circ\text{C}$ TO 85°C

Symbol	Parameter	Test Conditions	Minimum	Typical	Maximum	Units
f_{OUT}	Output Frequency	Q0:Q11		25		MHz
		Q12/nQ12		100		MHz
		Q13, Q14		24		MHz
		Q15:Q16/nQ15:nQ16		100		MHz
$t_{jit(per)}$	Period Jitter, Peak-to-Peak	Q12/nQ12	BER = 10E-12, 100MHz		70	ps
		Q13, Q14	BER = 10E-12, 24MHz		95	ps
		Q15:Q16/nQ15:nQ16	BER = 10E-12, 100MHz		70	ps
$t_{jit(cc)}$	Cycle-to-Cycle Jitter; NOTE 1, 2	Q0:Q11	25MHz		30	ps
		Q12/nQ12	100MHz		80	ps
		Q13, Q14	24MHz		90	ps
		Q15:Q16/nQ15:nQ16	100MHz		70	ps
t_{RESET}	Minimum Reset Time for nRESET		1.6			ns
t_{OEPD}	Maximum Propagation Delay from OE Register to Clock				$10 + t_{PER}$	ns
t_L	PLL Lock Time				50	ms
F_{xtal}	Crystal Input Range; NOTE 1			25		MHz
F_M	SSC Modulation Frequency; NOTE 3		29		33.33	kHz
F_{MF}	SSC Modulation Factor; NOTE 3			-0.4	-0.5	%
SSC _{red}	Spectral Reduction; NOTE 3		4	6		dB
t_{STABLE}	Power-up to Stable Clock Output, NOTE 4, 5		500			ps
V_{MAX}	Absolute Maximum Output Voltage; NOTE 6, 7	HCSL Levels			1150	mV
V_{MIN}	Absolute Minimum Output Voltage; NOTE 6, 8	HCSL Levels	-300			mV
V_{rb}	Ringback Voltage; NOTE 4, 5	HCSL Levels	-100		100	mV
V_{CROSS}	Absolute Crossing Voltage; NOTE 6, 9, 10	HCSL Levels	250		550	mV
ΔV_{CROSS}	Total Variation of V_{CROSS} ; NOTE 6, 9, 11	HCSL Levels			140	mV
t_R / t_F	Output Rise/Fall Time	Q[0:11], Q13, Q14	20% - 80%	150	350	ps
	Rise/Fall Edge Rate; NOTE 4, 12			0.6	5	V/ns
odc	Output Duty Cycle; NOTE 4	Q[0:11]		42	58	%
		Q13, Q14		49	51	%
		Q12/nQ12, Q15/nQ15, Q16/nQ16		49	51	%

NOTE 1: This parameter is defined in accordance with JEDEC Standard 65.

NOTE 2: Only valid within the VCO operating range.

NOTE 3: Spread Spectrum clocking enabled.

NOTE 4: Measurement taken from differential waveform.

NOTE 5: T_{STABLE} is the time the differential clock must maintain a minimum $\pm 150\text{mV}$ differential voltage after rising/falling edges before it is allowed to droop back into the $V_{RB} \pm 100\text{mV}$ differential range. See Parameter Measurement Information Section.

NOTE 6: Measurement taken from single-ended waveform.

NOTES continued on next page.

NOTE 7: Defined as the maximum instantaneous voltage including overshoot. See Parameter Measurement Information Section.

NOTE 8: Defined as the minimum instantaneous voltage including undershoot. See Parameter Measurement Information Section.

NOTE 9: Measured at crossing point where the instantaneous voltage value of the rising edge of Qx equals the falling edge of nQx. See Parameter Measurement Information Section.

NOTE 10: Refers to the total variation from the lowest crossing point to the highest, regardless of which edge is crossing. Refers to all crossing points for this measurement. See Parameter Measurement Information Section.

NOTE 11: Defined as the total variation of all crossing voltage of Rising Qx and Falling nQx. This is the maximum allowed variance in the V_{CROSS} for any particular system. See Parameter Measurement Information Section.

NOTE 12: Measured from -150mV to +150mV on the differential waveform (derived from Qx minus nQx). The signal must be monotonic through the measurement region for rise and fall time. The 300mV measurement window is centered on the differential zero crossing. See Parameter Measurement Information Section.

PARAMETER MEASUREMENT INFORMATION

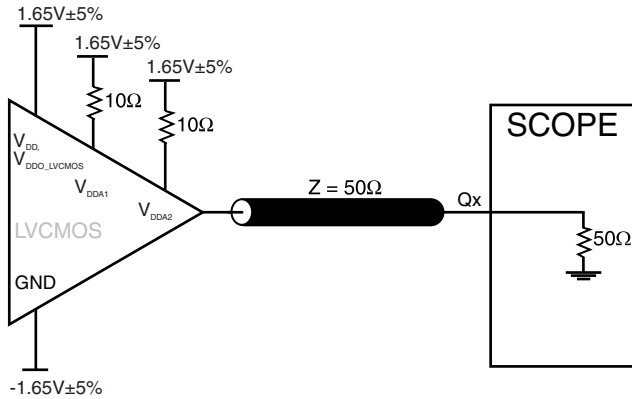
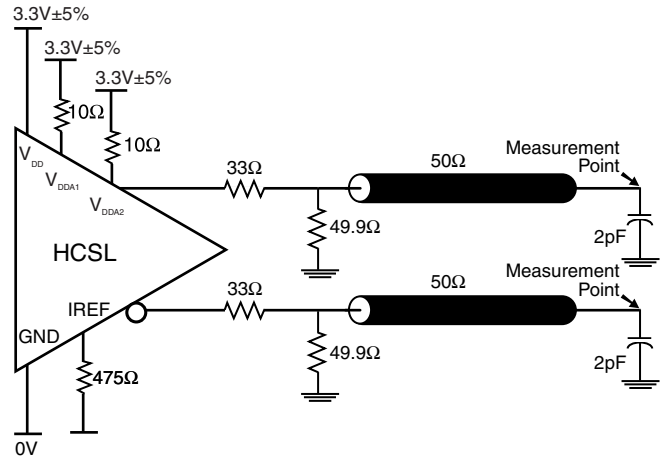
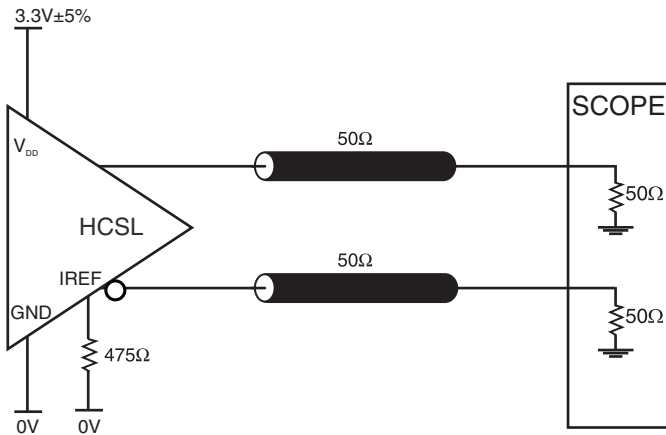
3.3V CORE/3.3V LVC MOS OUTPUT LOAD AC TEST CIRCUIT

3.3V CORE/3.3V HCSL OUTPUT LOAD AC TEST CIRCUIT

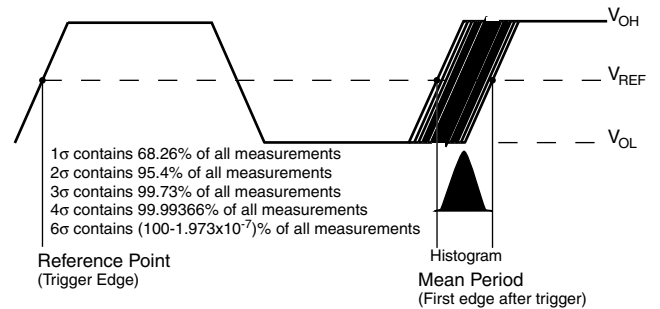
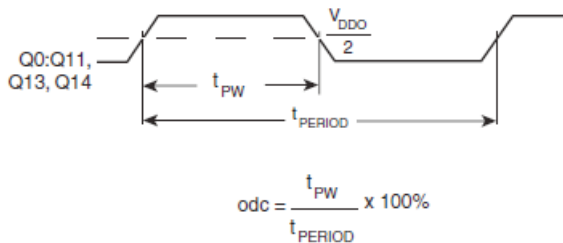
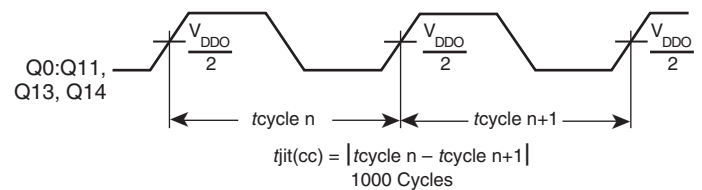
This load condition is used for I_{DD} , I_{DDA1} , I_{DDA2} and t_{jit} measurements.

HCSL OUTPUT LOAD AC TEST CIRCUIT

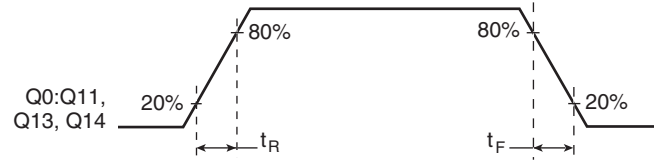
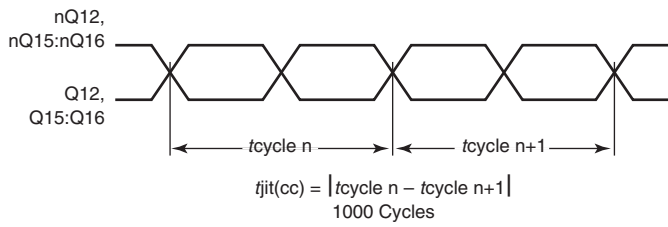
PERIOD JITTER

LVC MOS OUTPUT DUTY CYCLE/PULSE WIDTH/PERIOD

LVC MOS CYCLE-TO-CYCLE JITTER

PARAMETER MEASUREMENT INFORMATION, CONTINUED

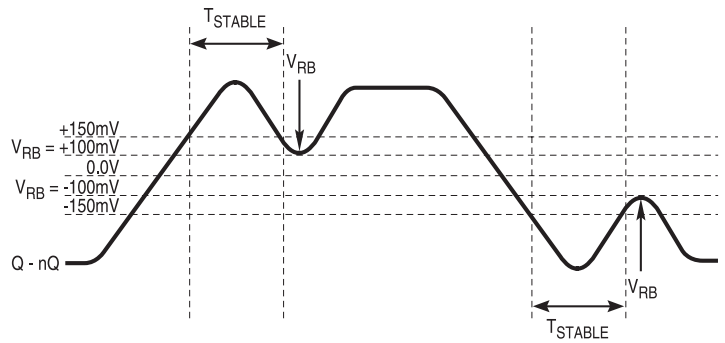
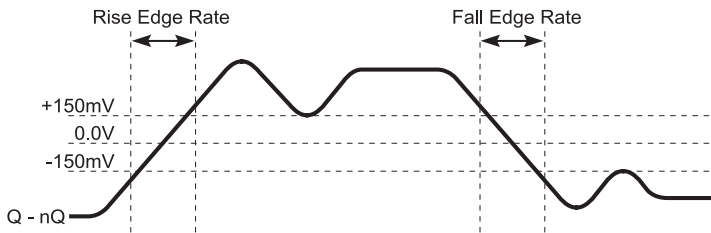

HCSL CYCLE-TO-CYCLE JITTER

LVCMOS OUTPUT RISE/FALL TIME



DIFFERENTIAL HCSL MEASUREMENT POINTS FOR RISE/FALL EDGE RATE

DIFFERENTIAL MEASUREMENT POINTS FOR RINGBACK

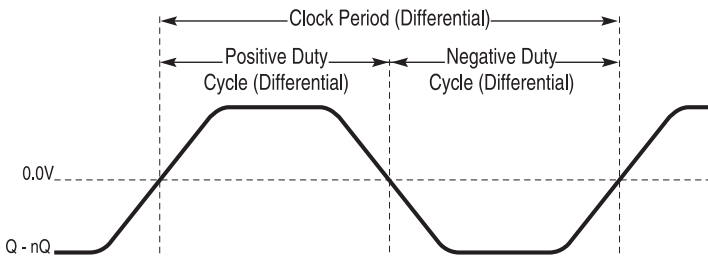

HCSL DIFFERENTIAL MEASUREMENT POINTS FOR DUTY CYCLE/PERIOD

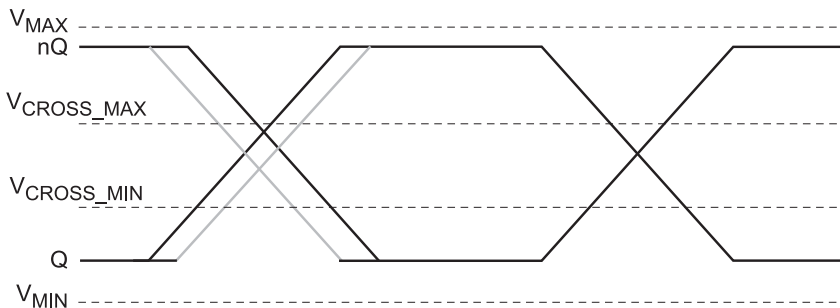

SINGLE-ENDED MEASUREMENT POINTS FOR ABSOLUTE CROSS POINT/SWING

APPLICATION INFORMATION

POWER SUPPLY FILTERING TECHNIQUES

As in any high speed analog circuitry, the power supply pins are vulnerable to random noise. To achieve optimum jitter performance, power supply isolation is required. The 844S2416 provides separate power supplies to isolate any high switching noise from the outputs to the internal PLL. V_{DD} , V_{DDAX} and V_{DDO_LVCMOS} should be individually connected to the power supply plane through vias, and $0.01\mu\text{F}$ bypass capacitors should be used for each pin. *Figure 1* illustrates this for a generic V_{DD} pin and also shows that V_{DDA} requires that an additional 10Ω resistor along with a $10\mu\text{F}$ bypass capacitor be connected to the V_{DDA} pin.

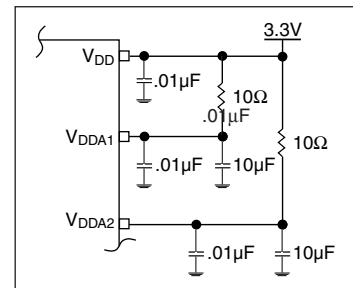

FIGURE 1. POWER SUPPLY FILTERING

RECOMMENDATIONS FOR UNUSED INPUT AND OUTPUT PINS

INPUTS:

LVC MOS CONTROL PINS

All control pins have internal pull-ups or pull-downs; additional resistance is not required but can be added for additional protection. A $1\text{k}\Omega$ resistor can be used.

OUTPUTS:

LVC MOS OUTPUTS

All unused LVC MOS output can be left floating. We recommend that there is no trace attached.

DIFFERENTIAL OUTPUTS

All unused differential outputs can be left floating. We recommend that there is no trace attached. Both sides of the differential output pair should either be left floating or terminated.

CRYSTAL INPUT INTERFACE

The 844S2416 has been characterized with 18pF parallel resonant crystals. The capacitor values shown in *Figure 2* below were determined using a 25MHz, 18pF parallel resonant crystal and

were chosen to minimize the ppm error. The value can be varied for different board layouts.

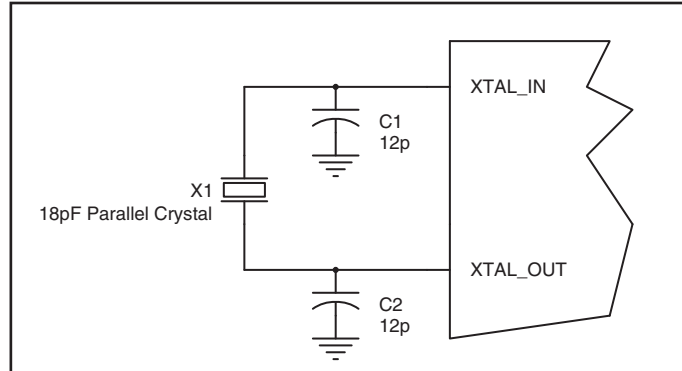

FIGURE 2. CRYSTAL INPUT INTERFACE

LVC MOS TO XTAL INTERFACE

The XTAL_IN input can accept a single-ended LVC MOS signal through an AC coupling capacitor. A general interface diagram is shown in *Figure 3*. The XTAL_OUT pin can be left floating. The input edge rate can be as slow as 10ns. For LVC MOS inputs, it is recommended that the amplitude be reduced from full swing to half swing in order to prevent signal interference with the power rail and to reduce noise. This configuration requires that the output

impedance of the driver (R_o) plus the series resistance (R_s) equals the transmission line impedance. In addition, matched termination at the crystal input will attenuate the signal in half. This can be done in one of two ways. First, R_1 and R_2 in parallel should equal the transmission line impedance. For most 50Ω applications, R_1 and R_2 can be 100Ω. This can also be accomplished by removing R_1 and making R_2 50Ω.

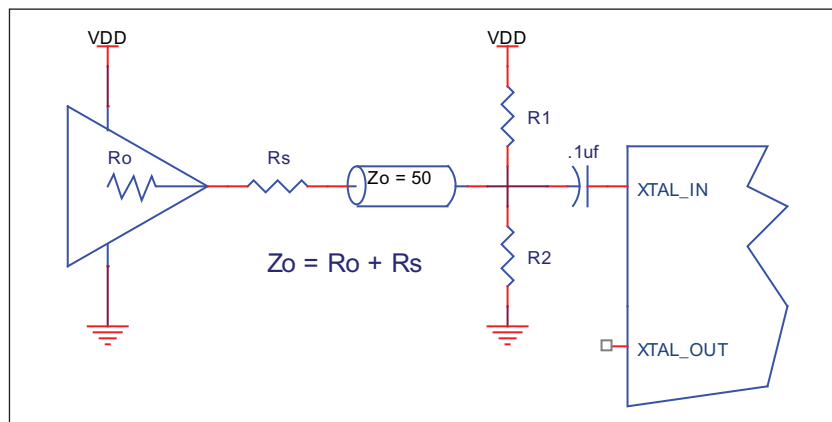

FIGURE 3. GENERAL DIAGRAM FOR LVC MOS DRIVER TO XTAL INPUT INTERFACE

VFQFN EPAD THERMAL RELEASE PATH

In order to maximize both the removal of heat from the package and the electrical performance, a land pattern must be incorporated on the Printed Circuit Board (PCB) within the footprint of the package corresponding to the exposed metal pad or exposed heat slug on the package, as shown in *Figure 4*. The solderable area on the PCB, as defined by the solder mask, should be at least the same size/shape as the exposed pad/slug area on the package to maximize the thermal/electrical performance. Sufficient clearance should be designed on the PCB between the outer edges of the land pattern and the inner edges of pad pattern for the leads to avoid any shorts.

While the land pattern on the PCB provides a means of heat transfer and electrical grounding from the package to the board through a solder joint, thermal vias are necessary to effectively conduct from the surface of the PCB to the ground plane(s). The land pattern must be connected to ground through these vias. The vias act as “heat pipes”. The number of vias (i.e. “heat pipes”) are application

specific and dependent upon the package power dissipation as well as electrical conductivity requirements. Thus, thermal and electrical analysis and/or testing are recommended to determine the minimum number needed. Maximum thermal and electrical performance is achieved when an array of vias is incorporated in the land pattern. It is recommended to use as many vias connected to ground as possible. It is also recommended that the via diameter should be 12 to 13mils (0.30 to 0.33mm) with 1oz copper via barrel plating. This is desirable to avoid any solder wicking inside the via during the soldering process which may result in voids in solder between the exposed pad/slug and the thermal land. Precautions should be taken to eliminate any solder voids between the exposed heat slug and the land pattern. Note: These recommendations are to be used as a guideline only. For further information, refer to the Application Note on the *Surface Mount Assembly* of Amkor’s Thermally/Electrically Enhance Leadframe Base Package, Amkor Technology.

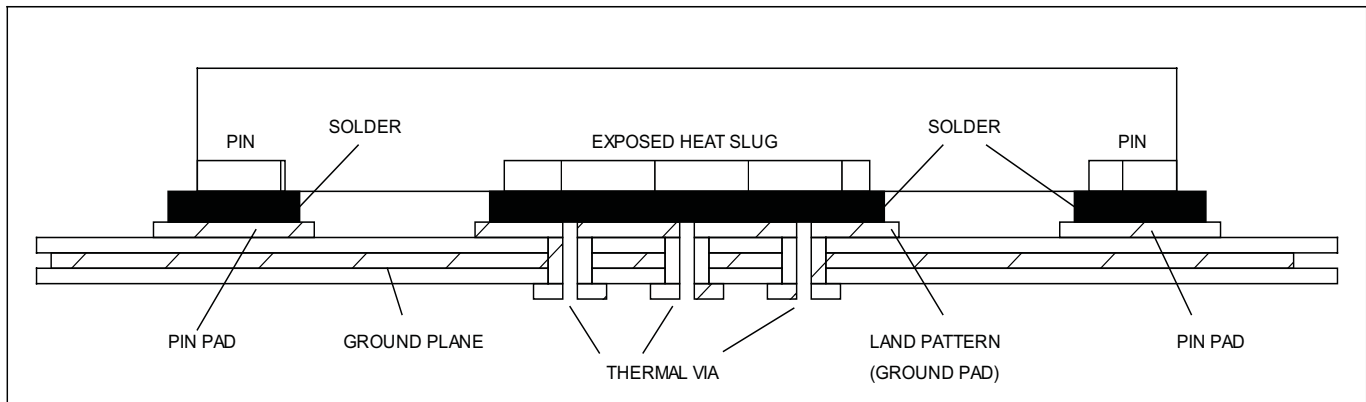

FIGURE 4. P.C. ASSEMBLY FOR EXPOSED PAD THERMAL RELEASE PATH –SIDE VIEW (DRAWING NOT TO SCALE)

RECOMMENDED TERMINATION

Figure 5A is the recommended termination for applications which require the receiver and driver to be on a separate PCB. All traces should be 50Ω impedance.

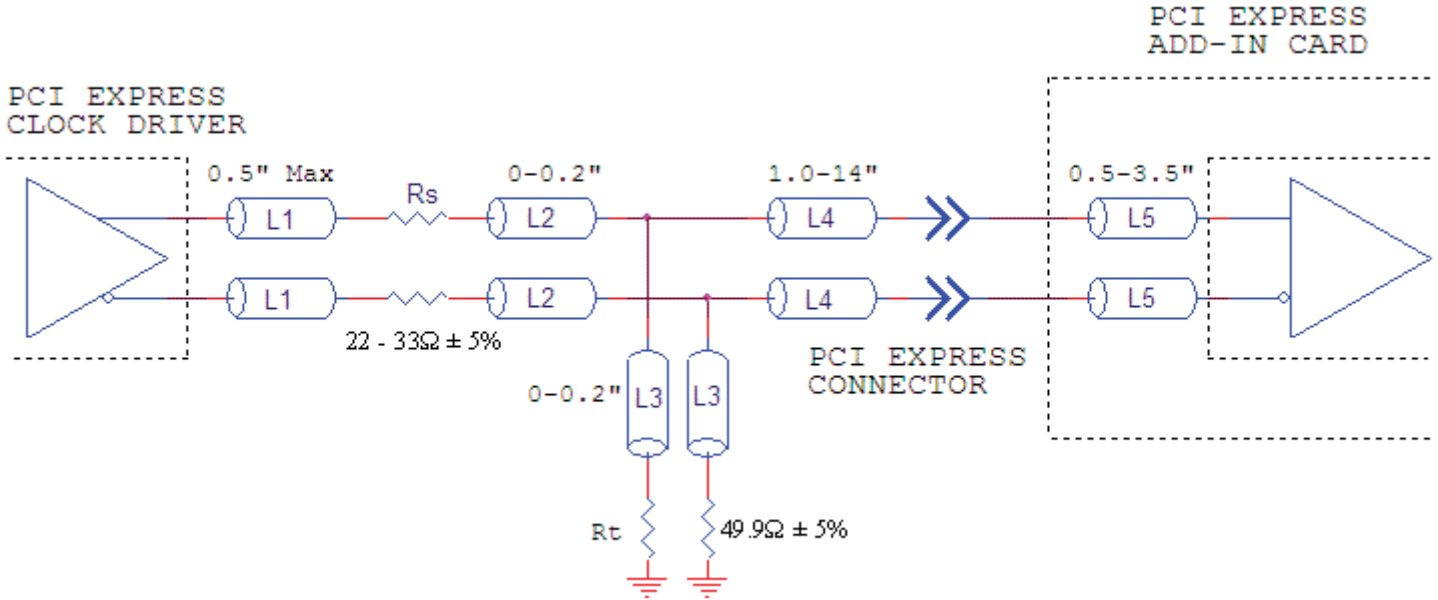

FIGURE 5A. RECOMMENDED TERMINATION

Figure 5B is the recommended termination for applications which require a point to point connection and contain the driver and

receiver on the same PCB. All traces should all be 50Ω impedance.

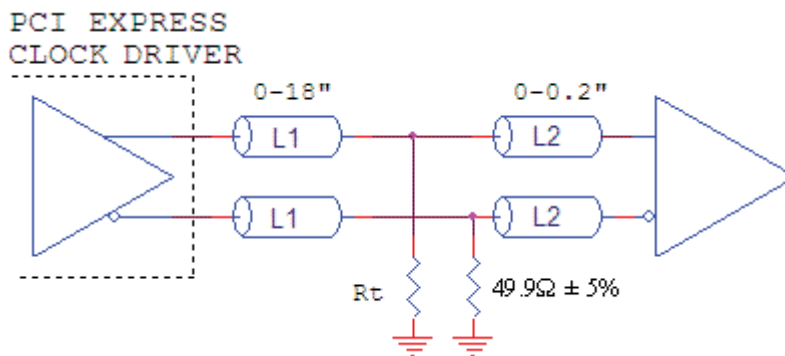

FIGURE 5B. RECOMMENDED TERMINATION

POWER CONSIDERATIONS

This section provides information on power dissipation and junction temperature for the 844S2416. Equations and example calculations are also provided.

1. Power Dissipation.

The total power dissipation for the 844S2416 is the sum of the core power plus the analog power plus the power dissipated in the load(s). The following is the power dissipation for $V_{DD} = 3.3V + 5\% = 3.465V$, which gives worst case results.

Core and HCSL Output Power Dissipation

- Power (core)_{MAX} = $V_{DD_MAX} * (I_{DD} + I_{DDA1} + I_{DDA2}) = 3.465V * (170 + 9mA + 22mA) = \mathbf{696.5mW}$
- Power (HCSL)_{MAX} = **44.5mW/Loaded Output Pair**
If all outputs are loaded, the total power is $3 * 44.5mW = \mathbf{133.5mW}$

LVC MOS Output Power Dissipation

- Output Impedance R_{OUT} Power Dissipation due to Loading 50Ω to $V_{DDO}/2$
Output Current $I_{OUT} = V_{DDO_MAX} / [2 * (50\Omega + R_{OUT})] = 3.465V / [2 * (50\Omega + 21\Omega)] = \mathbf{24.4mA}$
- Power Dissipation on the R_{OUT} per LVC MOS output
Power (R_{OUT}) = $R_{OUT} * (I_{OUT})^2 = 21\Omega * (24.4mA)^2 = \mathbf{12.5mW \text{ per output}}$
- Total Power Dissipation on the R_{OUT}
Total Power (R_{OUT}) = $12.5mW * 14 = \mathbf{175mW}$
- Dynamic Power Dissipation at 24MHz and 25MHz
Power Dynamic = $V_{DDO_LVC_MOS_MAX} * I_{DDO_LVC_MOS} = 3.465V * 16mA = \mathbf{55.44mW}$

Total Power Dissipation

- **Total Power**
= Power (core) + Power (HCSL) + Total Power (R_{OUT}) + Total Power (R_{OUT}) + Total Power (Dynamic)
= $696.5mW + 133.5mW + 175mW + 55.44mW$
= **1060.4mW**

2. Junction Temperature.

Junction temperature at the junction of the bond wire and bond pad directly affects the reliability of the device. The maximum recommended junction temperature is 125°C. Limiting the internal transistor junction temperature, T_j , to 125°C ensures that the bond wire and bond pad temperature remains below 125°C.

The equation for T_j is as follows: $T_j = \theta_{JA} * Pd_total + T_A$

T_j = Junction Temperature

θ_{JA} = Junction-to-Ambient Thermal Resistance

Pd_total = Total Device Power Dissipation (example calculation is in section 1 above)

T_A = Ambient Temperature

In order to calculate junction temperature, the appropriate junction-to-ambient thermal resistance θ_{JA} must be used. Assuming air flow of 1 meter per second and a multi-layer board, the appropriate value is 27.5°C/W per Table 7.

Therefore, T_j for an ambient temperature of 85°C with all outputs switching is:

$$85^\circ\text{C} + 1.06\text{W} * 27.5^\circ\text{C/W} = 114.2^\circ\text{C}. \text{ This is below the limit of } 125^\circ\text{C}.$$

This calculation is only an example. T_j will obviously vary depending on the number of loaded outputs, supply voltage, air flow, and the type of board.

TABLE 7. THERMAL RESISTANCE θ_{JA} FOR 56-LEAD VFQFN, FORCED CONVECTION

θ_{JA} vs. Air Flow (Meters per Second)			
	0	1	2.5
Multi-Layer PCB, JEDEC Standard Test Boards	31.4°C/W	27.5°C/W	24.6°C/W

3. Calculations and Equations.

The purpose of this section is to calculate power dissipation on the IC per HCSL output pair.

HCSL output driver circuit and termination are shown in *Figure 6*.

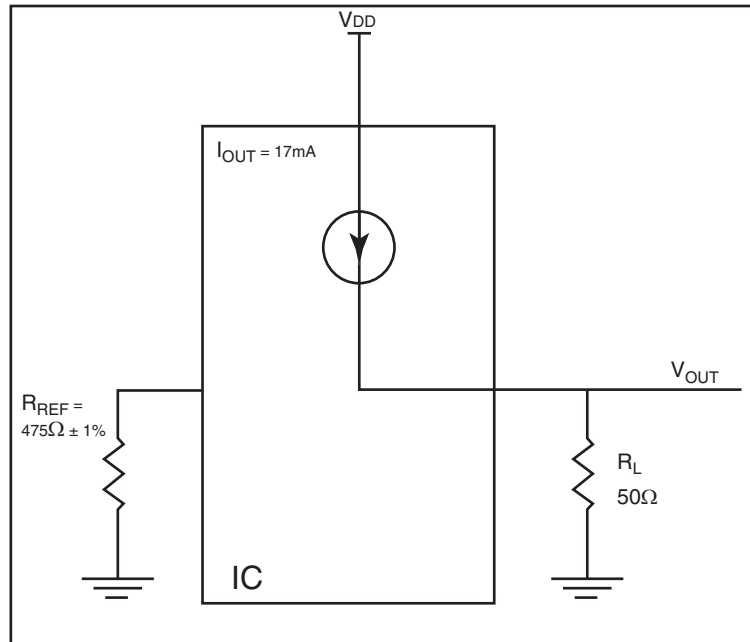

FIGURE 6. HCSL DRIVER CIRCUIT AND TERMINATION

HCSL is a current steering output which sources a maximum of 17mA of current per output. To calculate worst case on-chip power dissipation, use the following equations which assume a 50Ω load to ground.

The highest power dissipation occurs when V_{DD} is HIGH.

$$\begin{aligned} \text{Power} &= (V_{DD_HIGH} - V_{OUT}) * I_{OUT}, \text{ since } V_{OUT} = I_{OUT} * R_L \\ &= (V_{DD_HIGH} - I_{OUT} * R_L) * I_{OUT} \\ &= (3.465V - 17mA * 50\Omega) * 17mA \end{aligned}$$

Total Power Dissipation per output pair = **44.5mW**

RELIABILITY INFORMATION

TABLE 8. θ_{JA} VS. AIR FLOW TABLE FOR 56 LEAD VFQFN

θ_{JA} by Velocity (Meters per second)			
	0	1	2.5
Multi-Layer PCB, JEDEC Standard Test Boards	31.4°C/W	27.5°C/W	24.6°C/W

TRANSISTOR COUNT

The transistor count for 844S2416 is: 13,890

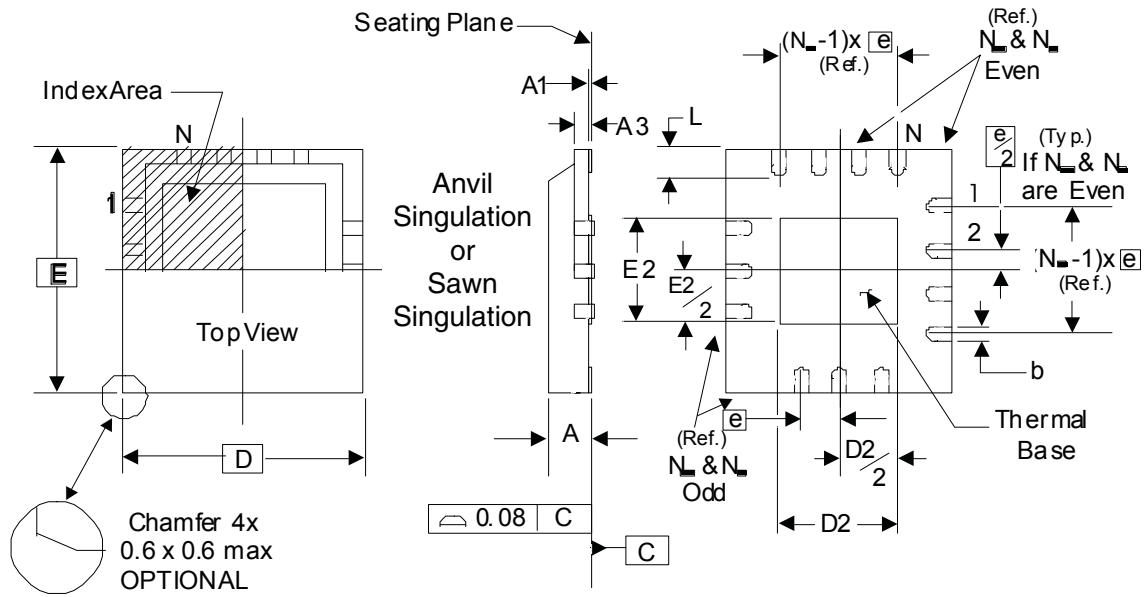
PACKAGE OUTLINE - K SUFFIX FOR 56 LEAD VFQFN

NOTE: The following package mechanical drawing is a generic drawing that applies to any pin count VFQFN package. This drawing is not intended to convey the actual pin count or pin layout of this

device. The pin count and pinout are shown on the front page. The package dimensions are in Table 8 below.

TABLE 9. PACKAGE DIMENSIONS

JEDEC VARIATION ALL DIMENSIONS IN MILLIMETERS		
SYMBOL	MINIMUM	MAXIMUM
N	56	
A	0.80	1.0
A1	0	0.05
A3	0.25 Reference	
b	0.18	0.30
e	0.50 BASIC	
N_d	14	
N_e	14	
D	8.0	
D2	4.35	4.65
E	8.0	
E2	5.05	5.35
L	0.3	0.55

Reference Document: JEDEC Publication 95, MO-220

TABLE 10. ORDERING INFORMATION

Part/Order Number	Marking	Package	Shipping Packaging	Temperature
844S2416CKILF	ICS44S2416CIL	56 lead "Lead Free" VFQFN	tray	-40°C to 85°C
844S2416CKILFT	ICS44S2416CIL	56 lead "Lead Free" VFQFN	tape & reel, Pin 1 orientation (EIA-481-C)	-40°C to 85°C
844S2416CKILF/W	ICS44S2416CIL	56 lead "Lead Free" VFQFN	tape & reel, Pin 1 orientation, (EIA-481-D)	-40°C to 85°C

TABLE 11. PIN 1 ORIENTATION IN TAPE AND REEL PACKAGING

Part Number Suffix	Pin 1 Orientation	Illustration
T	Quadrant 1 (EIA-481-C)	
W	Quadrant 2 (EIA-481-D)	

REVISION HISTORY SHEET				
Rev	Table	Page	Description of Change	Date
A		1 17	General Description - deleted HiperClocks logo. First sentence, deleted HiperClocks reference. Power Considerations - updated <i>Junction Temperature</i> sentence.	12/2/13
A	T10 T11	21 21	Ordering Information - Added W part number. Added Pin 1 orientation table.	7/6/15
A	T10	21	Ordering Information - Deleted LF note below table. Updated data sheet header and footer.	4/29/16



Corporate Headquarters
6024 Silver Creek Valley Road
San Jose, CA 95138 USA
www.IDT.com

Sales
1-800-345-7015 or 408-284-8200
Fax: 408-284-2775
www.IDT.com/go/sales

Tech Support
www.idt.com/go/support

DISCLAIMER Integrated Device Technology, Inc. (IDT) reserves the right to modify the products and/or specifications described herein at any time, without notice, at IDT's sole discretion. Performance specifications and operating parameters of the described products are determined in an independent state and are not guaranteed to perform the same way when installed in customer products. The information contained herein is provided without representation or warranty of any kind, whether express or implied, including, but not limited to, the suitability of IDT's products for any particular purpose, an implied warranty of merchantability, or non-infringement of the intellectual property rights of others. This document is presented only as a guide and does not convey any license under intellectual property rights of IDT or any third parties.

IDT's products are not intended for use in applications involving extreme environmental conditions or in life support systems or similar devices where the failure or malfunction of an IDT product can be reasonably expected to significantly affect the health or safety of users. Anyone using an IDT product in such a manner does so at their own risk, absent an express, written agreement by IDT.

Integrated Device Technology, IDT and the IDT logo are trademarks or registered trademarks of IDT and its subsidiaries in the United States and other countries. Other trademarks used herein are the property of IDT or their respective third party owners.

For datasheet type definitions and a glossary of common terms, visit www.idt.com/go/glossary.

Copyright ©2016 Integrated Device Technology, Inc. All rights reserved.



Компания «ЭлектроПласт» предлагает заключение долгосрочных отношений при поставках импортных электронных компонентов на взаимовыгодных условиях!

Наши преимущества:

- Оперативные поставки широкого спектра электронных компонентов отечественного и импортного производства напрямую от производителей и с крупнейших мировых складов;
- Поставка более 17-ти миллионов наименований электронных компонентов;
- Поставка сложных, дефицитных, либо снятых с производства позиций;
- Оперативные сроки поставки под заказ (от 5 рабочих дней);
- Экспресс доставка в любую точку России;
- Техническая поддержка проекта, помощь в подборе аналогов, поставка прототипов;
- Система менеджмента качества сертифицирована по Международному стандарту ISO 9001;
- Лицензия ФСБ на осуществление работ с использованием сведений, составляющих государственную тайну;
- Поставка специализированных компонентов (Xilinx, Altera, Analog Devices, Intersil, Interpoint, Microsemi, Aeroflex, Peregrine, Syfer, Eurofarad, Texas Instrument, Miteq, Cobham, E2V, MA-COM, Hittite, Mini-Circuits, General Dynamics и др.);

Помимо этого, одним из направлений компании «ЭлектроПласт» является направление «Источники питания». Мы предлагаем Вам помощь Конструкторского отдела:

- Подбор оптимального решения, техническое обоснование при выборе компонента;
- Подбор аналогов;
- Консультации по применению компонента;
- Поставка образцов и прототипов;
- Техническая поддержка проекта;
- Защита от снятия компонента с производства.



Как с нами связаться

Телефон: 8 (812) 309 58 32 (многоканальный)

Факс: 8 (812) 320-02-42

Электронная почта: org@eplast1.ru

Адрес: 198099, г. Санкт-Петербург, ул. Калинина, дом 2, корпус 4, литера А.