

GaAs SPDT Switch DC - 3.0 GHz

Rev. V1

Features

- Low Insertion Loss: < 0.3 dB @ 900 MHz
- Low Power Consumption: < 15 μ A @ -2.3 Volts
- Positive or Negative 2.3 to 8 Volt Control
- Lead-Free SC-70 (SOT-363) Package
- 100% Matte Tin Plating over Copper
- Halogen-Free "Green" Mold Compound
- 260°C Reflow Compatible
- RoHS* Compliant version of SW-456

Description

M/A-COM's MASW-007221 is a GaAs monolithic switch in a lead-free SC-70 (SOT-363) surface mount plastic package. The MASW-007221 is ideally suited for applications where very low power consumption, low insertion loss, very small size, and low cost are required. Typical applications are in dual band systems where switching between small signal components is required, i.e. filter banks, single-band LNA's, converters, etc.

The MASW-007221 can be used in applications up to 0.25 watts in systems such as cellular, PCS, DCS1800, GSM, CDMA, W-CDMA and other analog / digital wireless communication systems.

The MASW-007221 is fabricated using a mature 0.5 micron PHEMT process. The process features full passivation for performance and reliability.

Ordering Information ¹

Part Number	Package
MASW-007221-000000	Bulk Packaging
MASW-007221-TR3000	3000 piece reel

1. Reference Application Note M513 for reel size information.

Functional Schematic: Positive Control Voltage

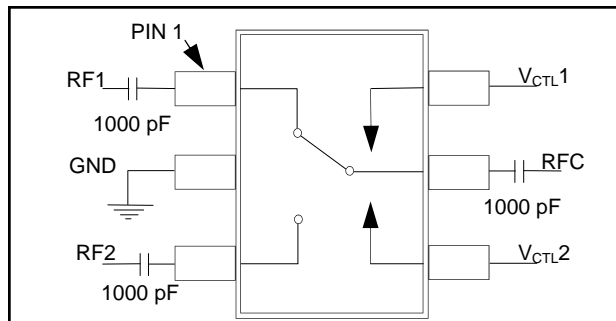

Functional Schematic: Negative Control Voltage

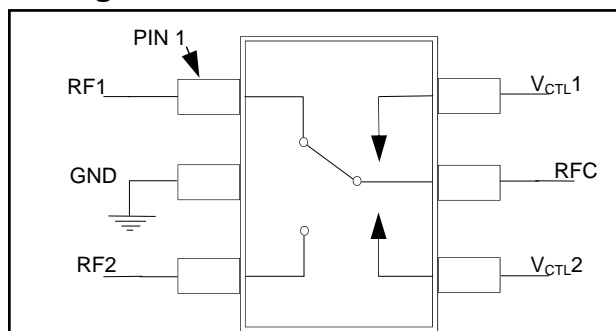

Pin Configuration

PIN	Function	Description
1	RF1	RF In/Out
2	GND	RF Ground
3	RF2	RF In/Out
4	V_CTL2	Voltage Control 2
5	RFC	RF Common
6	V_CTL1	Voltage Control 1

Absolute Maximum Ratings ^{2,3}

Parameter	Absolute Maximum
Input Power (0.5 - 3.0 GHz) 3 V Control 5 V Control	+30 dBm +33 dBm
Operating Voltage	+8.5 volts
Operating Temperature	-40°C to +85°C
Storage Temperature	-65°C to +150°C

2. Exceeding any one or combination of these limits may cause permanent damage to this device.

3. M/A-COM does not recommend sustained operation near these survivability limits.

¹ * Restrictions on Hazardous Substances, European Union Directive 2002/95/EC.

ADVANCED: Data Sheets contain information regarding a product M/A-COM Technology Solutions is considering for development. Performance is based on target specifications, simulated results, and/or prototype measurements. Commitment to develop is not guaranteed.

PRELIMINARY: Data Sheets contain information regarding a product M/A-COM Technology Solutions has under development. Performance is based on engineering tests. Specifications are typical. Mechanical outline has been fixed. Engineering samples and/or test data may be available. Commitment to produce in volume is not guaranteed.

• **North America** Tel: 800.366.2266 / Fax: 978.366.2266
 • **Europe** Tel: 44.1908.574.200 / Fax: 44.1908.574.300
 • **Asia/Pacific** Tel: 81.44.844.8296 / Fax: 81.44.844.8298
 Visit www.macomtech.com for additional data sheets and product information.

M/A-COM Technology Solutions Inc. and its affiliates reserve the right to make changes to the product(s) or information contained herein without notice.

GaAs SPDT Switch DC - 3.0 GHz

Rev. V1

Electrical Specifications: $T_A = 25^\circ\text{C}$, $V_{CTL} = 0, -2.3$ volts (unless otherwise specified), $Z_0 = 50$

Parameter	Test Conditions	Units	Min.	Typ.	Max.
Insertion Loss ⁵	DC - 1 GHz	dB	—	0.35	0.5
	1 - 2 GHz	dB	—	0.45	0.6
	2 - 3 GHz	dB	—	0.56	0.8
Isolation	DC - 1 GHz	dB	20	22	—
	1 - 2 GHz	dB	15	17	—
	2 - 3 GHz	dB	10	12	—
V_{SWR}	DC - 3 GHz	Ratio	—	1.2:1	1.4:1
P_{1dB} (2.3V supply)	500 MHz - 3 GHz	dBm	—	21	—
P_{1dB} (3V supply)	500 MHz - 3 GHz	dBm	—	27	—
Input IP_2	2-Tone 900 MHz, 5 MHz spacing (3.0 V)	dBm	—	81	—
Input IP_3	2-Tone 900 MHz, 5 MHz spacing (3.0 V)	dBm	—	52	—
Trise, Tfall	10% to 90% RF, 90% to 10% RF	ns	—	25	—
Ton, Toff	50% Control to 90% RF, Control to 10% RF	ns	—	25	—
Transients	In-Band	mV	—	25	—
Control Current	$V_{CTL} = -2.3$ V	μA	—	4	15

4. External DC blocking capacitors are required on all RF ports when using positive voltage control.

5. Insertion loss can be optimized by varying the DC blocking capacitor value, e.g. 1000 pF for 100 MHz - 1 GHz, 39 pF for 0.5 GHz - 3 GHz.

Truth Table

Mode (Control)	V1	V2	RFC - RF1	RFC - RF2
Positive ⁶	0 ± 0.2 V	+2.3 to +8 V	Off	On
	+2.3 to +8 V	0 ± 0.2 V	On	Off
Negative ⁷	0 ± 0.2 V	-2.3 V to -8 V	On	Off
	-2.3 V to -8 V	0 ± 0.2 V	Off	On

6. External DC blocking capacitors are required on all RF ports. 1000 pF capacitors used for positive control voltage. For higher frequency operation, smaller value DC blocking capacitors can be substituted.

7. If negative control is used, DC blocking capacitors are not required on RF ports.

Qualification

Qualified to M/A-COM specification REL-201, Process Flow -2.

Handling Procedures

Please observe the following precautions to avoid damage:

Static Sensitivity

Gallium Arsenide Integrated Circuits are sensitive to electrostatic discharge (ESD) and can be damaged by static electricity. Proper ESD control techniques should be used when handling these devices.

Lead-Free SC-70 (SOT-363) [†]

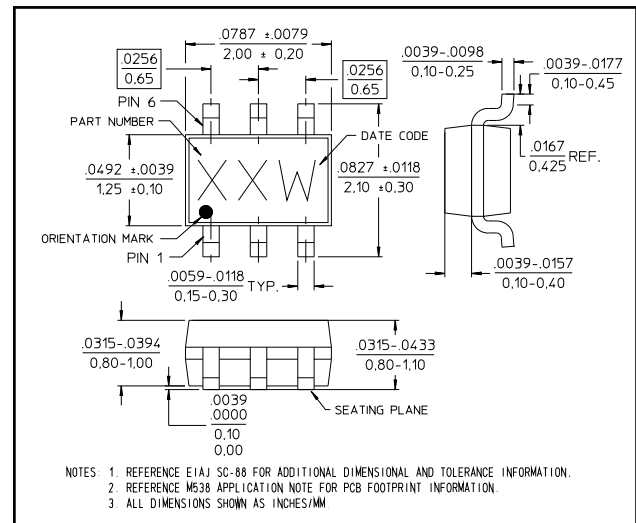

[†] Reference Application Note M538 for lead-free solder reflow recommendations.

Typical Performance Curves

Insertion Loss vs. Frequency Over Temperature

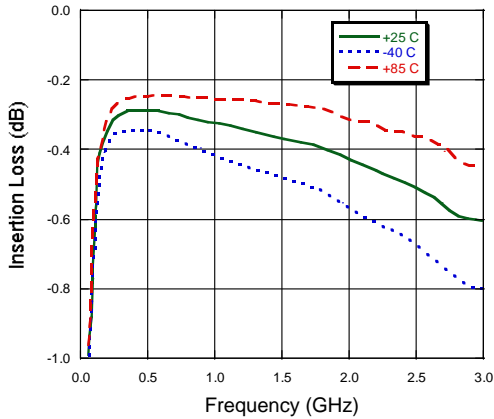

VSWR Over Temperature

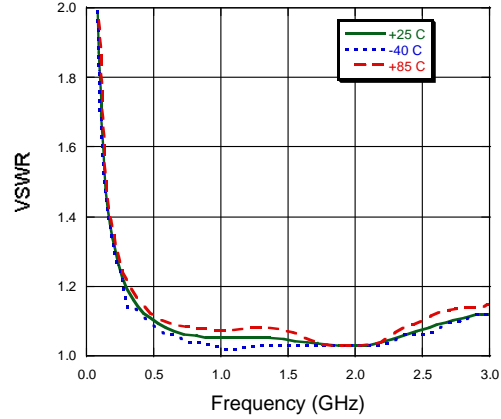

Isolation vs. Frequency Over Temperature

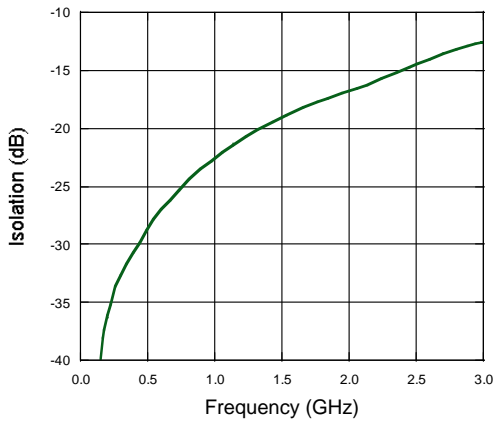

Insertion Loss vs. Frequency (+2.3 V Control, 1000 pF Capacitor on RF Ports)

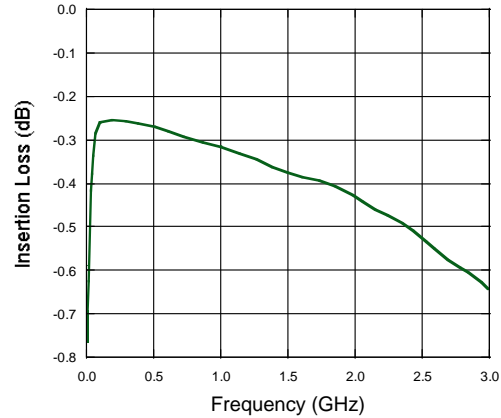

Isolation vs. Frequency (+2.3 V Control, 1000 pF Capacitor on RF Ports)

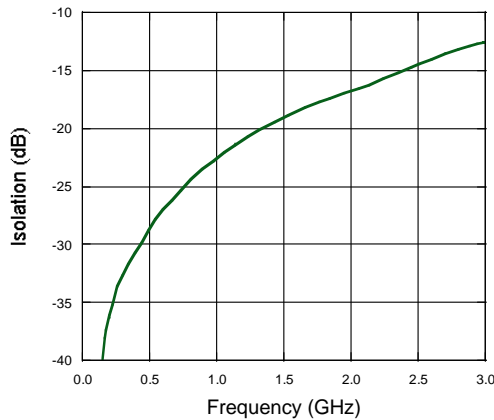

VSWR vs. Frequency (+2.3 V Control, 1000 pF Capacitor on RF Ports)

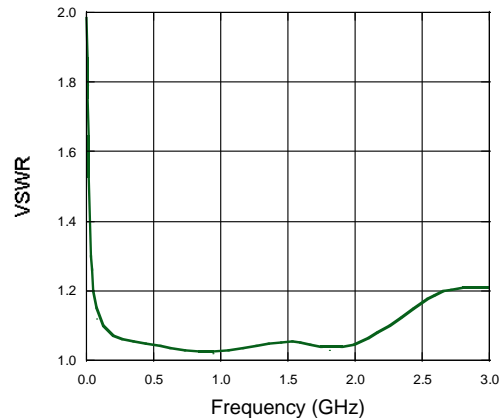



Компания «ЭлектроПласт» предлагает заключение долгосрочных отношений при поставках импортных электронных компонентов на взаимовыгодных условиях!

Наши преимущества:

- Оперативные поставки широкого спектра электронных компонентов отечественного и импортного производства напрямую от производителей и с крупнейших мировых складов;
- Поставка более 17-ти миллионов наименований электронных компонентов;
- Поставка сложных, дефицитных, либо снятых с производства позиций;
- Оперативные сроки поставки под заказ (от 5 рабочих дней);
- Экспресс доставка в любую точку России;
- Техническая поддержка проекта, помощь в подборе аналогов, поставка прототипов;
- Система менеджмента качества сертифицирована по Международному стандарту ISO 9001;
- Лицензия ФСБ на осуществление работ с использованием сведений, составляющих государственную тайну;
- Поставка специализированных компонентов (Xilinx, Altera, Analog Devices, Intersil, Interpoint, Microsemi, Aeroflex, Peregrine, Syfer, Eurofarad, Texas Instrument, Miteq, Cobham, E2V, MA-COM, Hittite, Mini-Circuits, General Dynamics и др.);

Помимо этого, одним из направлений компании «ЭлектроПласт» является направление «Источники питания». Мы предлагаем Вам помощь Конструкторского отдела:

- Подбор оптимального решения, техническое обоснование при выборе компонента;
- Подбор аналогов;
- Консультации по применению компонента;
- Поставка образцов и прототипов;
- Техническая поддержка проекта;
- Защита от снятия компонента с производства.



Как с нами связаться

Телефон: 8 (812) 309 58 32 (многоканальный)

Факс: 8 (812) 320-02-42

Электронная почта: org@eplast1.ru

Адрес: 198099, г. Санкт-Петербург, ул. Калинина, дом 2, корпус 4, литера А.