

Si1144-AAGX Data Short

Optical Heart Rate Sensor Module with I²C Interface and HR Measurement Software

The Si1144-AAGX is a low-power, reflectance-based, heart rate sensor. This optical heart rate sensor module includes an analog-to-digital converter, integrated high-sensitivity photodiodes, host communications processor, a green high efficiency LED, and three integrated LED drivers with ninety selectable drive levels. The Si1144-AAGX offers excellent performance under a wide dynamic range and a variety of light sources from 525 nm to 940 nm. The Si1144-AAGX devices are provided in a 10-lead 4.9 x 2.85 x 1.2 mm LGA module package and are capable of operation from 1.71 to 3.6 V over the -40 to +85 °C temperature range.

Applications:

- Fitness Bands
- Smart Watches
- Other Wearables
- Healthcare

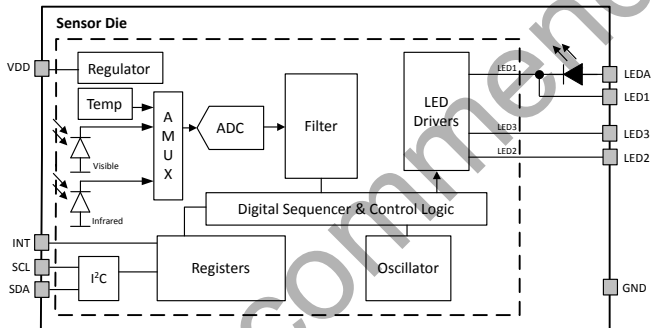

Si1144-AAGX Sensor Module Block Diagram

KEY FEATURES

- Fully integrated heart rate sensor with ARM code library for extracting HR from the optical sensor data
 - Green LED with lens
 - High-sensitivity photodiode
 - Low-noise analog-to-digital converter and filtering
 - LED drivers
 - Optical blocking
 - Host communications and interrupts
- Optional Movement compensation uses external accelerometer data
- Accurate sensing of weak blood flow signals on the wrist
- Three independent regulated LED drivers
 - Scalable from cost-sensitive single LED systems to high performance three LED systems
 - Programmable from 6 mA to 360 mA each
- Integrated green LED ideal for wrist based heart rate applications
 - Add up to 2 external LEDs
 - Broad spectral sensitivity supports green through 940 nm LEDs
- No additional optical blocking required
- Low power consumption
 - 1.71 to 3.6 V supply voltage
 - 25.6 μ s LED "on" time keeps total power consumption duty cycle low without compromising performance or noise immunity
 - < 500 nA standby current
 - Internal and external wake support
 - Built-in voltage supply monitor and power-on reset controller
- I²C serial communications
 - Up to 3.4 Mbps data rate
 - Slave mode hardware address decoding (0x5A)
- 10-lead 4.9 X 2.85 x 1.2 mm LGA Module package
- Temperature Range
 - -40 to +85 °C

1. Si1144-AAGX Information

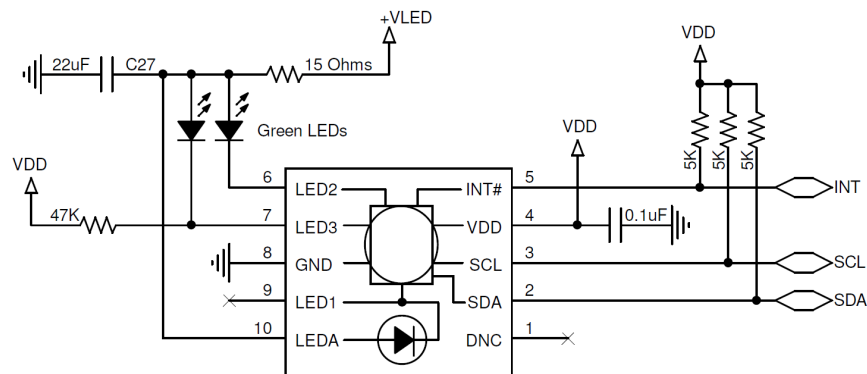

Si1144-AAGX 4.9 x 2.85 x 1.3 mm LGA Module Application Schematic

Table 1.1. Recommended Operating Conditions

Parameter	Symbol	Test Condition	Min	Typ	Max	Unit
V _{DD} Supply Voltage	V _{DD}		1.71	—	3.6	V
V _{DD} OFF Supply Voltage	V _{DD_OFF}	OFF mode	-0.3		1.0	V
V _{DD} Supply Ripple Voltage ¹		V _{DD} = 3.3 V 1 kHz–10 MHz	—	—	50	mVpp
Operating Temperature	T		-40	25	85	°C
SCL, SDA, Input High Logic Voltage	I ² C _{VIH}		V _{DD} × 0.7	—	V _{DD}	V
SCL, SDA Input Low Logic Voltage	I ² C _{VIL}		0	—	V _{DD} × 0.3	V
LED Emission Wavelength	λ		—	525	—	nm
LED Supply Voltage	V _{LED}		4.1	—	5.0	V
LED Supply Ripple Voltage ¹		0–30 kHz 30 kHz–100 MHz	— —	— —	250 100	mVpp mVpp
Start-Up Time		V _{DD} above 1.71 V	25	—	—	ms
LED3 Voltage		Start-up	V _{DD} × 0.7	—	—	V

Note:

1. Supply voltage ripple sensitivity depends on the voltage at the LEDx pins when turned on.

Table 1.2. Ordering Guide

Part Number	Package	LED Drivers
Si1144-AAGX-GMR	4.9 x 2.85 x 1.2 mm LGA Module	3 LED drivers, 1 green LED integrated

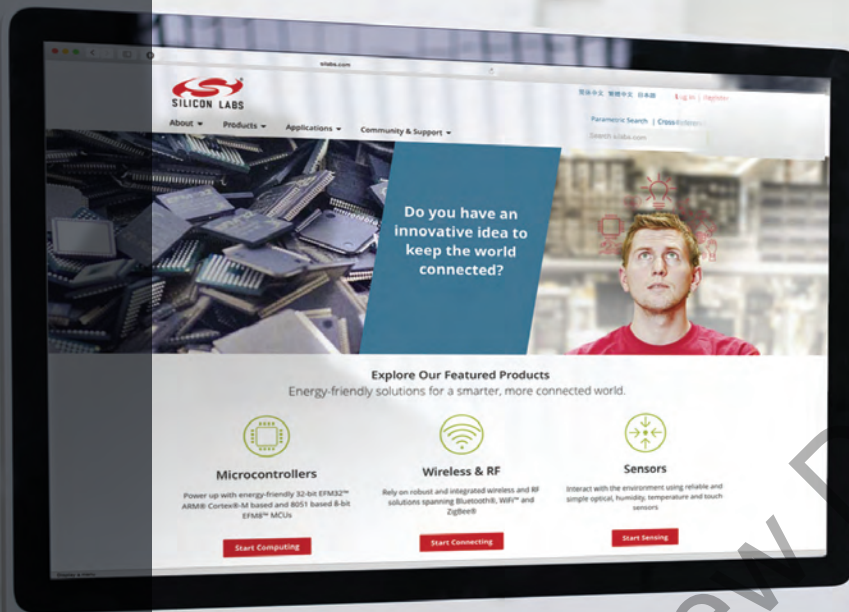

Smart.
Connected.
Energy-Friendly



Products
www.silabs.com/products



Quality
www.silabs.com/quality



Support and Community
community.silabs.com

Disclaimer

Silicon Laboratories intends to provide customers with the latest, accurate, and in-depth documentation of all peripherals and modules available for system and software implementers using or intending to use the Silicon Laboratories products. Characterization data, available modules and peripherals, memory sizes and memory addresses refer to each specific device, and "Typical" parameters provided can and do vary in different applications. Application examples described herein are for illustrative purposes only. Silicon Laboratories reserves the right to make changes without further notice and limitation to product information, specifications, and descriptions herein, and does not give warranties as to the accuracy or completeness of the included information. Silicon Laboratories shall have no liability for the consequences of use of the information supplied herein. This document does not imply or express copyright licenses granted hereunder to design or fabricate any integrated circuits. The products must not be used within any Life Support System without the specific written consent of Silicon Laboratories. A "Life Support System" is any product or system intended to support or sustain life and/or health, which, if it fails, can be reasonably expected to result in significant personal injury or death. Silicon Laboratories products are generally not intended for military applications. Silicon Laboratories products shall under no circumstances be used in weapons of mass destruction including (but not limited to) nuclear, biological or chemical weapons, or missiles capable of delivering such weapons.

Trademark Information

Silicon Laboratories Inc., Silicon Laboratories, Silicon Labs, SiLabs and the Silicon Labs logo, CMEMS®, EFM, EFM32, EFR, Energy Micro, Energy Micro logo and combinations thereof, "the world's most energy friendly microcontrollers", Ember®, EZLink®, EZMac®, EZRadio®, EZRadioPRO®, DSPLL®, ISOmodem®, Precision32®, ProSLIC®, SiPHY®, USBXpress® and others are trademarks or registered trademarks of Silicon Laboratories Inc. ARM, CORTEX, Cortex-M3 and THUMB are trademarks or registered trademarks of ARM Holdings. Keil is a registered trademark of ARM Limited. All other products or brand names mentioned herein are trademarks of their respective holders.



SILICON LABS

Silicon Laboratories Inc.
400 West Cesar Chavez
Austin, TX 78701
USA

<http://www.silabs.com>



Компания «ЭлектроПласт» предлагает заключение долгосрочных отношений при поставках импортных электронных компонентов на взаимовыгодных условиях!

Наши преимущества:

- Оперативные поставки широкого спектра электронных компонентов отечественного и импортного производства напрямую от производителей и с крупнейших мировых складов;
- Поставка более 17-ти миллионов наименований электронных компонентов;
- Поставка сложных, дефицитных, либо снятых с производства позиций;
- Оперативные сроки поставки под заказ (от 5 рабочих дней);
- Экспресс доставка в любую точку России;
- Техническая поддержка проекта, помощь в подборе аналогов, поставка прототипов;
- Система менеджмента качества сертифицирована по Международному стандарту ISO 9001;
- Лицензия ФСБ на осуществление работ с использованием сведений, составляющих государственную тайну;
- Поставка специализированных компонентов (Xilinx, Altera, Analog Devices, Intersil, Interpoint, Microsemi, Aeroflex, Peregrine, Syfer, Eurofarad, Texas Instrument, Miteq, Cobham, E2V, MA-COM, Hittite, Mini-Circuits, General Dynamics и др.);

Помимо этого, одним из направлений компании «ЭлектроПласт» является направление «Источники питания». Мы предлагаем Вам помощь Конструкторского отдела:

- Подбор оптимального решения, техническое обоснование при выборе компонента;
- Подбор аналогов;
- Консультации по применению компонента;
- Поставка образцов и прототипов;
- Техническая поддержка проекта;
- Защита от снятия компонента с производства.



Как с нами связаться

Телефон: 8 (812) 309 58 32 (многоканальный)

Факс: 8 (812) 320-02-42

Электронная почта: org@eplast1.ru

Адрес: 198099, г. Санкт-Петербург, ул. Калинина, дом 2, корпус 4, литера А.