

Part No. : **MA.203.A.A301621.B301721**

Product Name : GPS/Penta-band Cellular Adhesive Antenna

Feature : High gain LNA up to 32dB  
(GSM/CDMA/PCS/DCS/UMTS/GPRS/EDGE/ HSPA)  
Height 10.8mm Diameter 55.1mm  
IP65 Waterproof  
Fakra Connector  
ROHS Compliant



## 1 Introduction

This is a combination high performance GPS and Penta-band Cellular (GSM/CDMA/PCS/DCS/ / UMTS / GPRS / EDGE/ HSPA) antenna to simplify AVL or Fleet management antenna systems worldwide. Its high quality low profile covert housing can be attached onto the glass or even out of sight under the dashboard. This combination of a high gain GPS antenna and a leading edge Penta band cellular antenna is ideal for those applications that require durability, small size and covert installation, and reliable reception and transmission crossing through different mobile networks.

### Features

#### GPS

- High LNA Gain up to 32 dB
- Antenna Gain  $30 \pm 2$  dB
- Miniaturized to 55.15x12mm
- Low Noise 1.5 dB max

#### Cellular

- Advanced Penta-band cellular antenna (GSM/CDMA/PCS/DCS/UMTS/GPRS/EDGE/ HSPA)

#### Other

- Water Resistant IP 65(IP 67 MA.203 version also available)
- Quality textured covert design. Low profile
- UV resistant ABS housing
- Comes with high grade 3M double sided tape for quick and easy mounting
- Fakra code C (blue) on GPS and code D( violet) on GSM . Optional cables and connectors

## 2 Specification

### 2.1 GPS Antenna

GPS	
Centre Frequency	1575.42MHz
Bandwidth	10MHz
Average Gain	28dBic typ. (@DC 3V)
Radiation Efficiency	50%
Gain @ Zenith	4.0dBic typ.
Axial Ratio	3.0dB max.
Polarization	Right Hand Circular
VSWR	$\leq 2.0$
Impedance	50 $\Omega$
DC Power Input Range	3 ~ 5 V
DC input	3V
LNA Gain(Typ.)	28dB
Noise Figure(Typ.)	1.5dB
Power Consumption	7~9mA
Band Attenuation	$\pm 50$ MHz
	40dB
Cable	1M RG174 standard, fully customizable
Connector	SMA(M) standard, standard, fully customizable

## 2.2 Cellular Antenna

CELLULAR					
Frequency (MHz)	824~894	880~960	1710~1880	1850~1990	2110~2170
Peak gain (dBi)	>2.5	>0.0	>1.5	>2.5	>0.5
Efficiency	>60%	>45%	>40%	>45%	>50%
Impedance	50Ω				
Polarization	Linear				
VSWR	3 max.				
Cable	1M RG-174 standard, fully customizable				
Connector	SMA(M) standard, fully customizable				

### 3 Test Setup

#### 3.1 Configuration of SATIMO

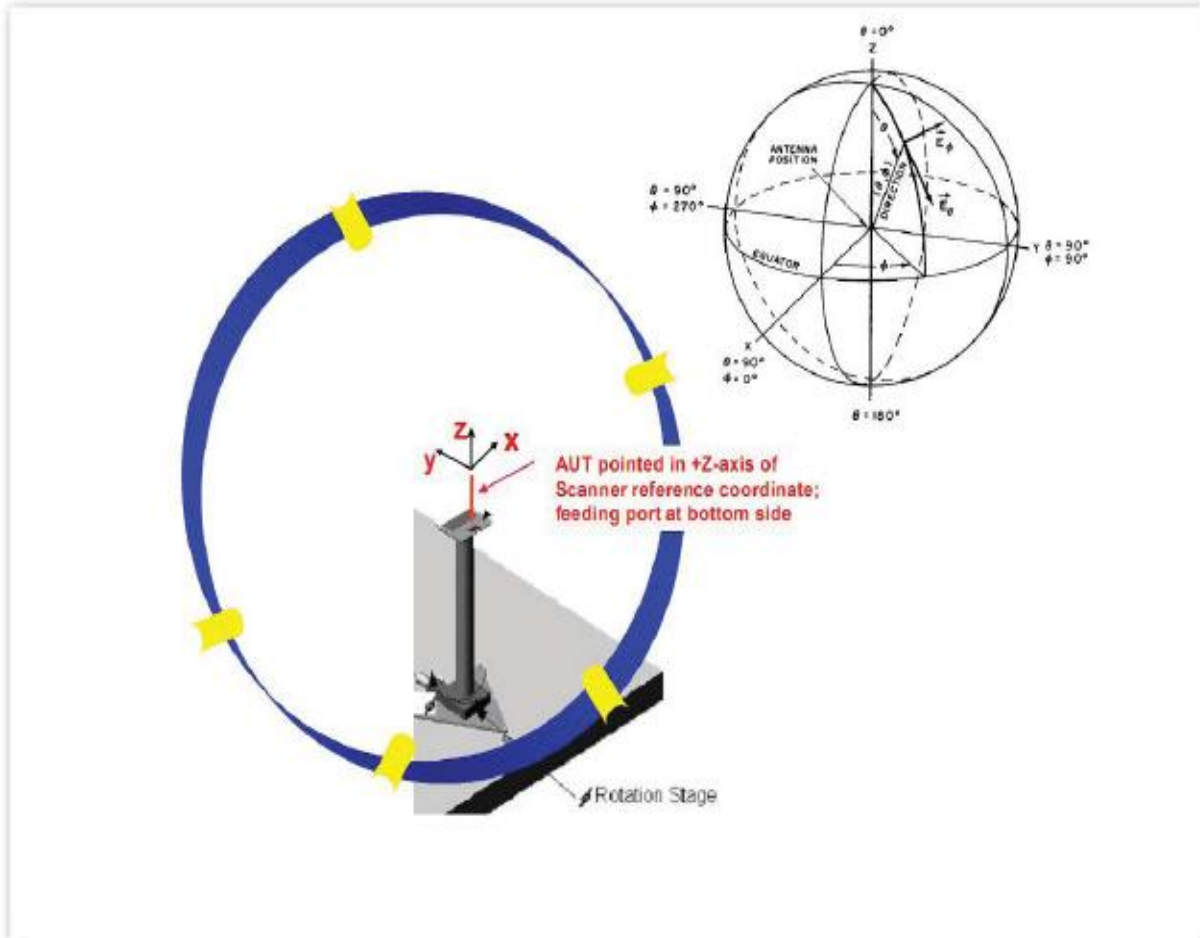

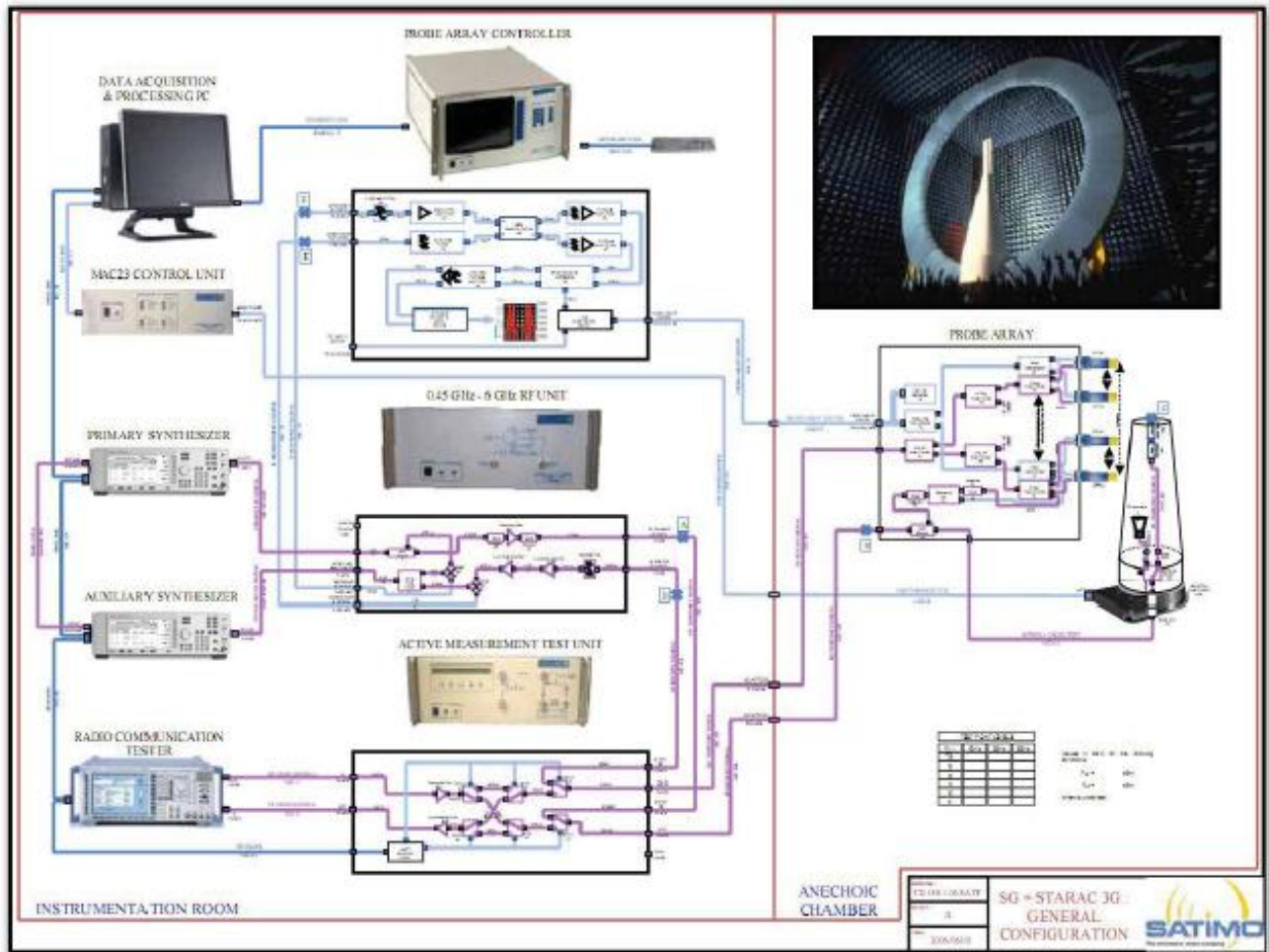



Agilent E5071B Network Analyzer



Anritsu 68147C Signal Generator

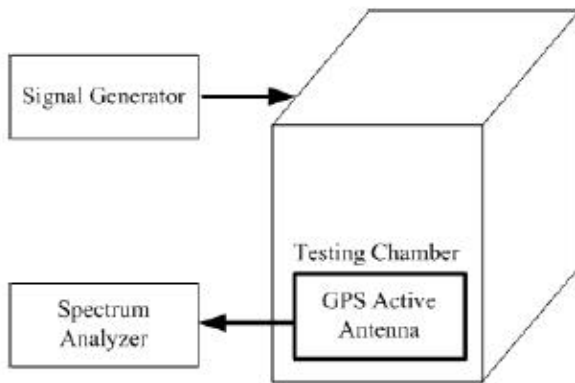

Testing Chamber



Anritsu MS2721A Spectrum

Cable attenuation(dB/100mm)												
GHz	0.5	1	1.5	2	2.5	3	3.5	4	4.5	5	5.5	6
RG-174	67	100	127	153	138	183	207	229	252	272	291	311
CFD-200	26	39	49	58	66	73		86		98		109

## 4 GPS Antenna Characteristics

### 4.1 Patch antenna S11

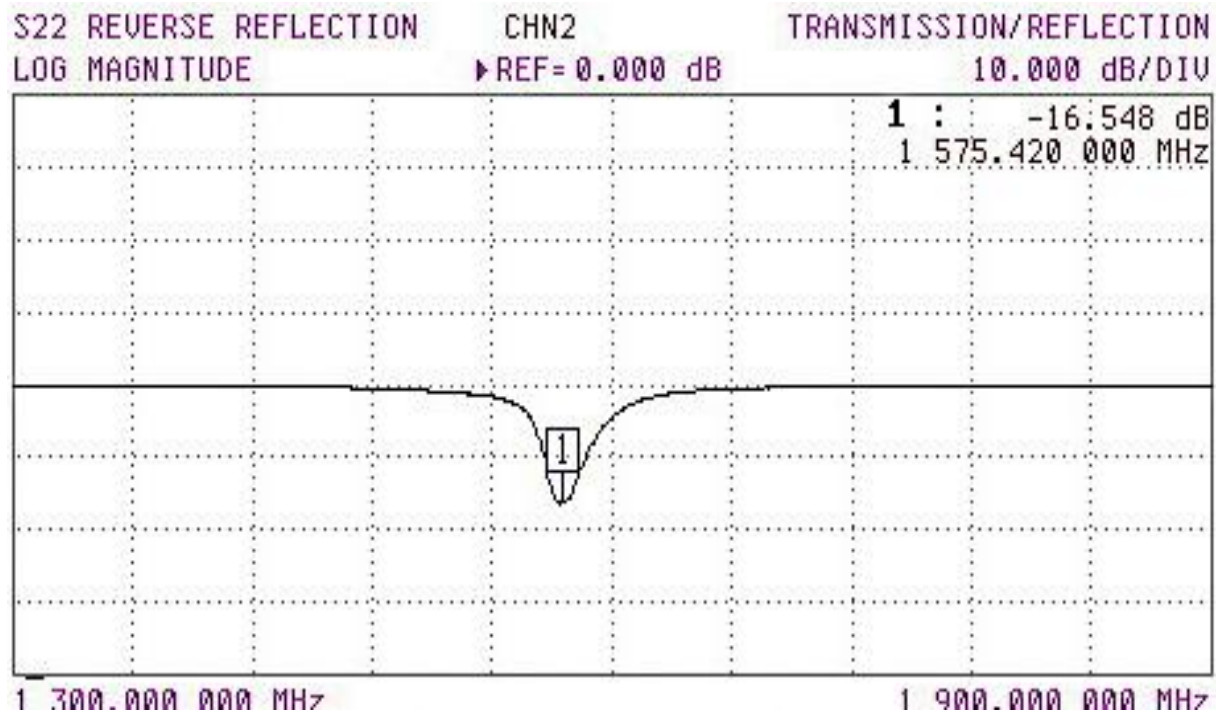



## 4.2 GPS antenna pattern( XZ plane)

Far-field amplitude of GPS\_1\_070108.nsi

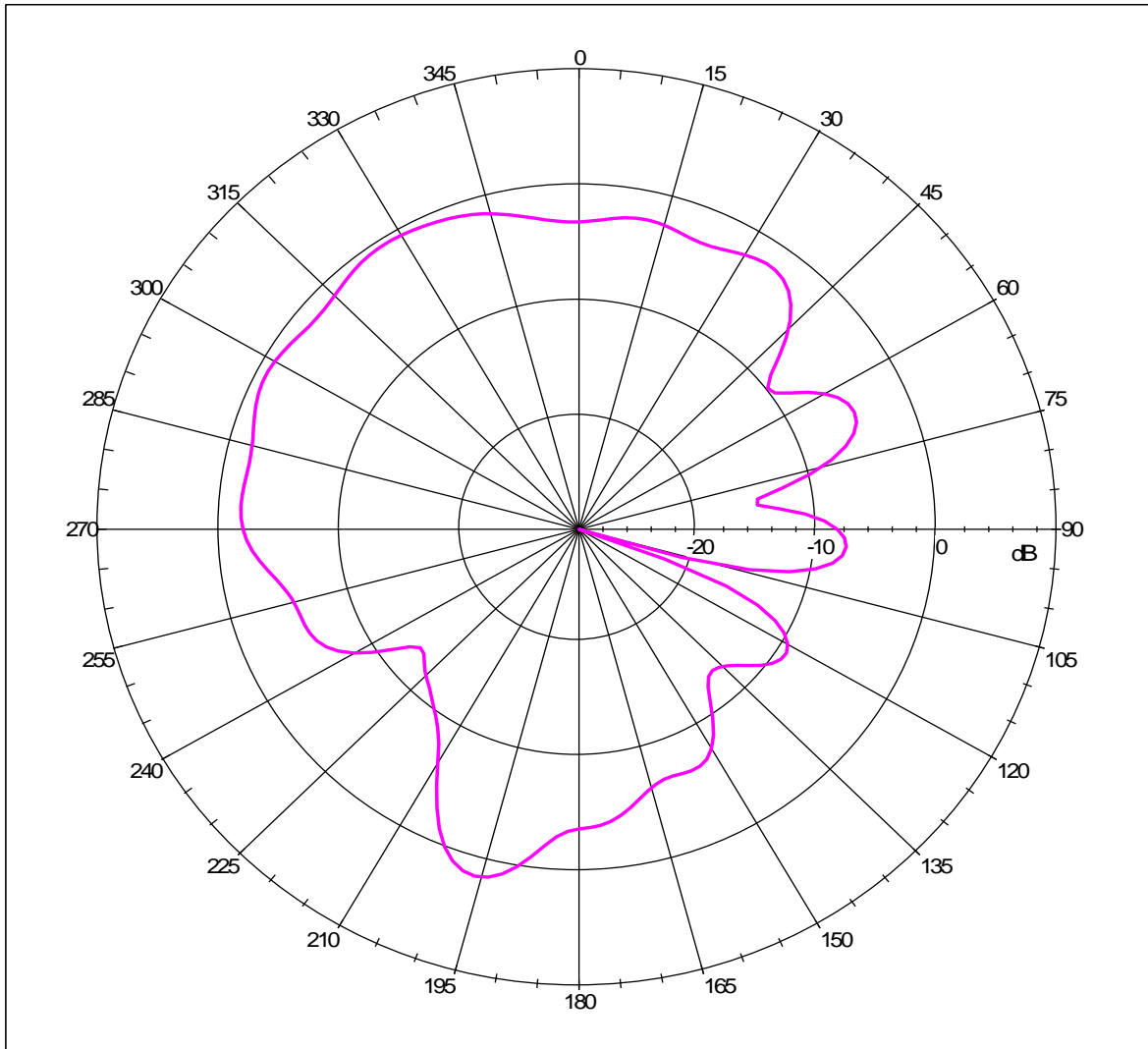

### 4.3 GPS antenna pattern (YZ plane)

Far-field amplitude of GPS\_1\_070108.nsi

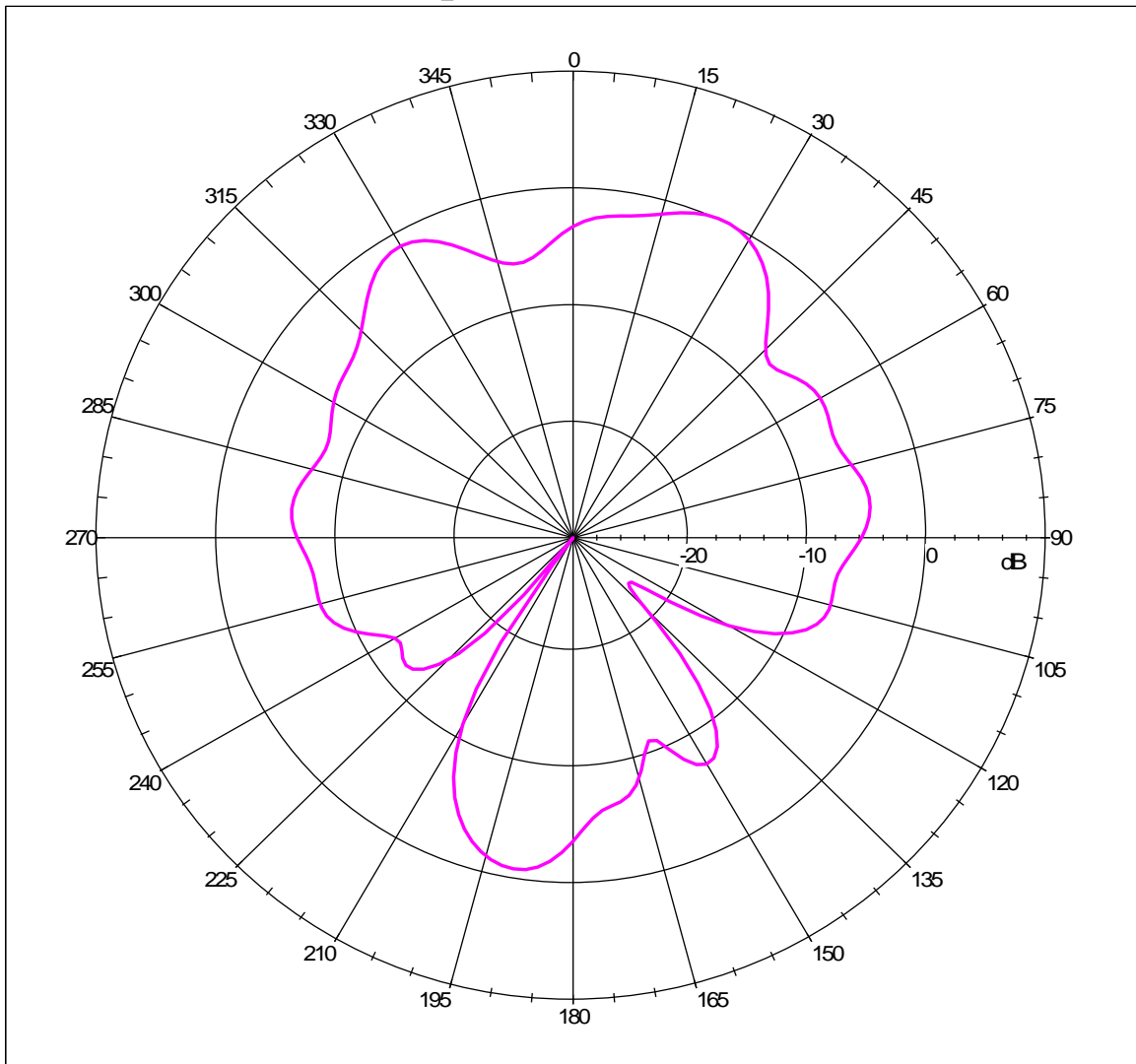

### 4.4 GPS antenna Gain(with LNA)

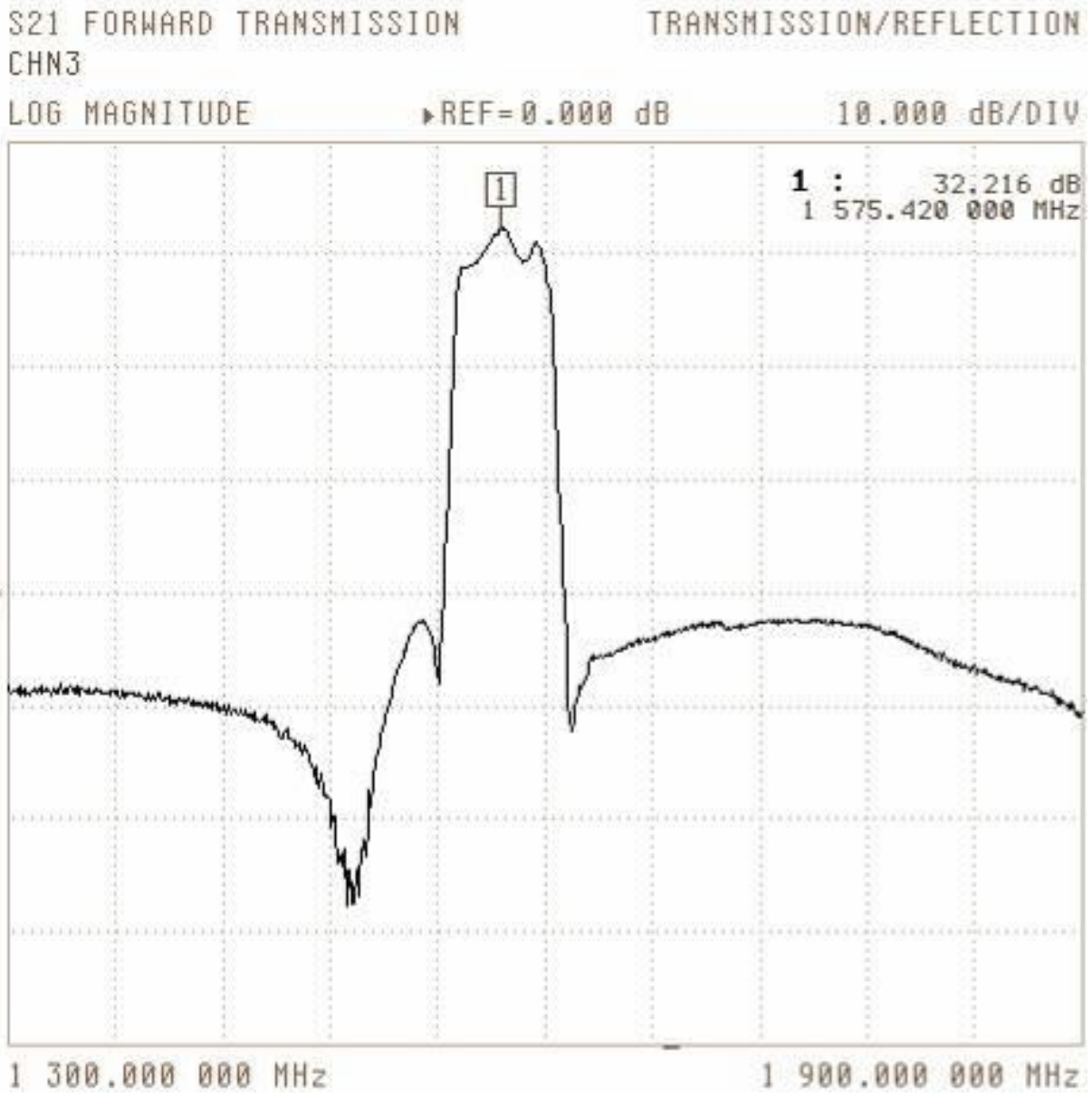

### 4.5 GPS antenna return loss (With LNA)

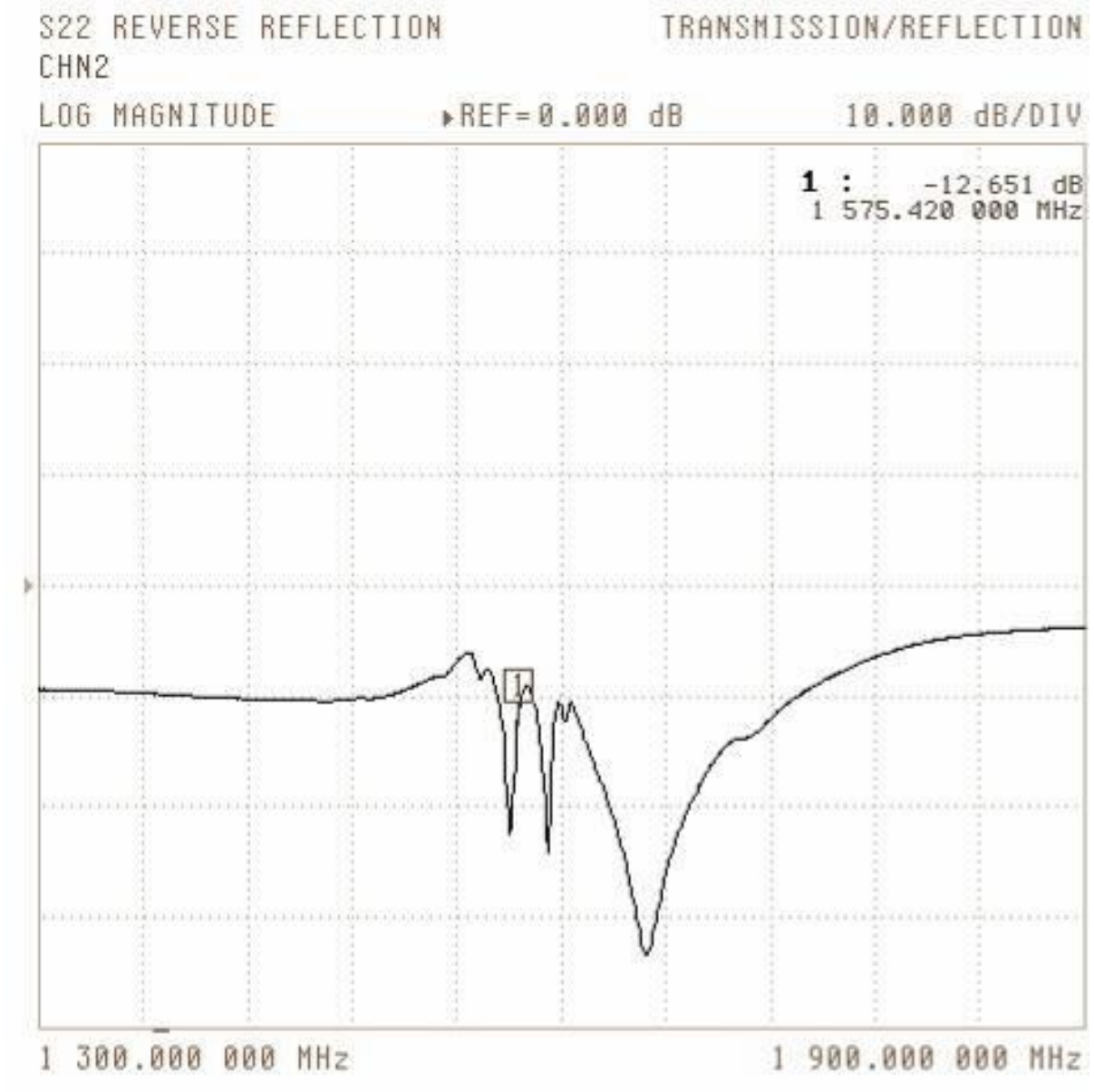

## 5 Cellular antenna

### 5.1 Return loss (with 1M RG-174 cable)



## 5.2 Radiation Pattern

### 5.2.1 XZ Plane

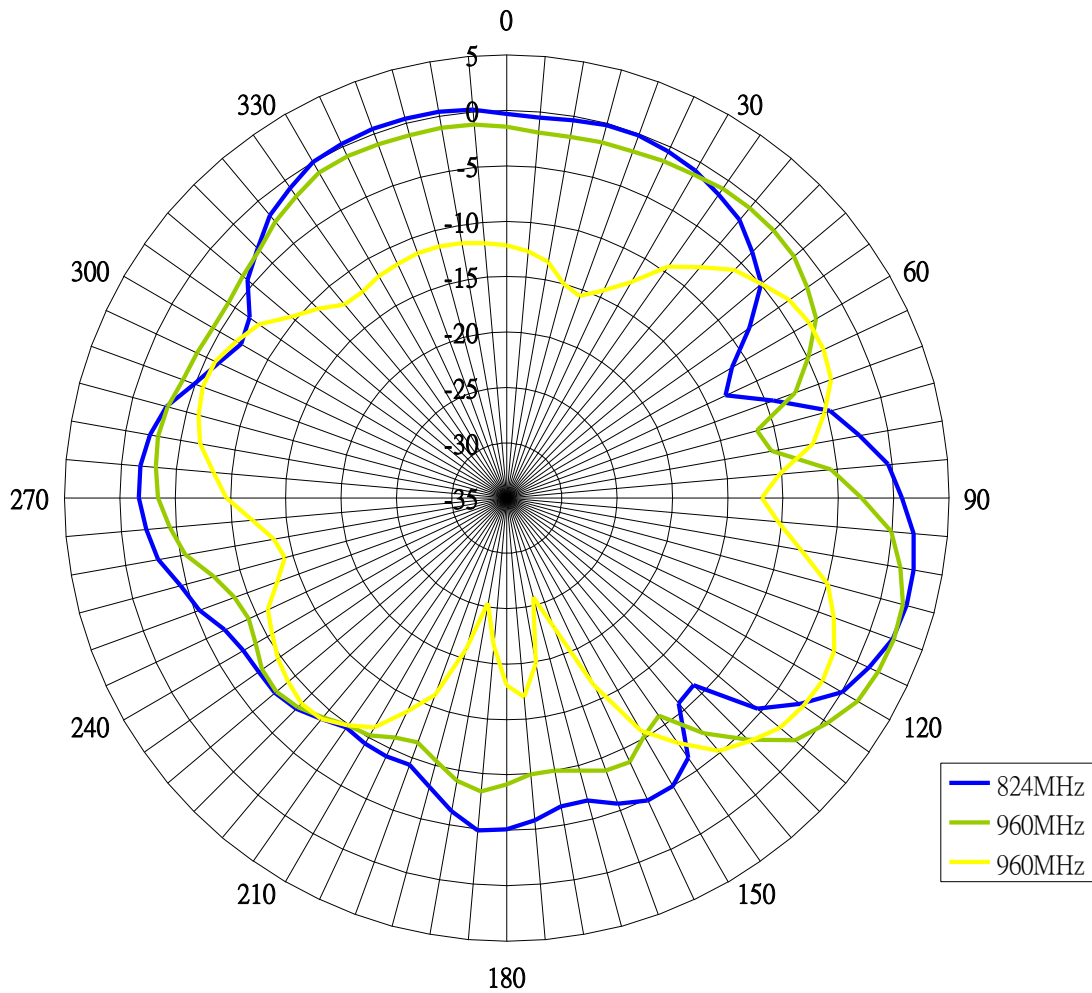

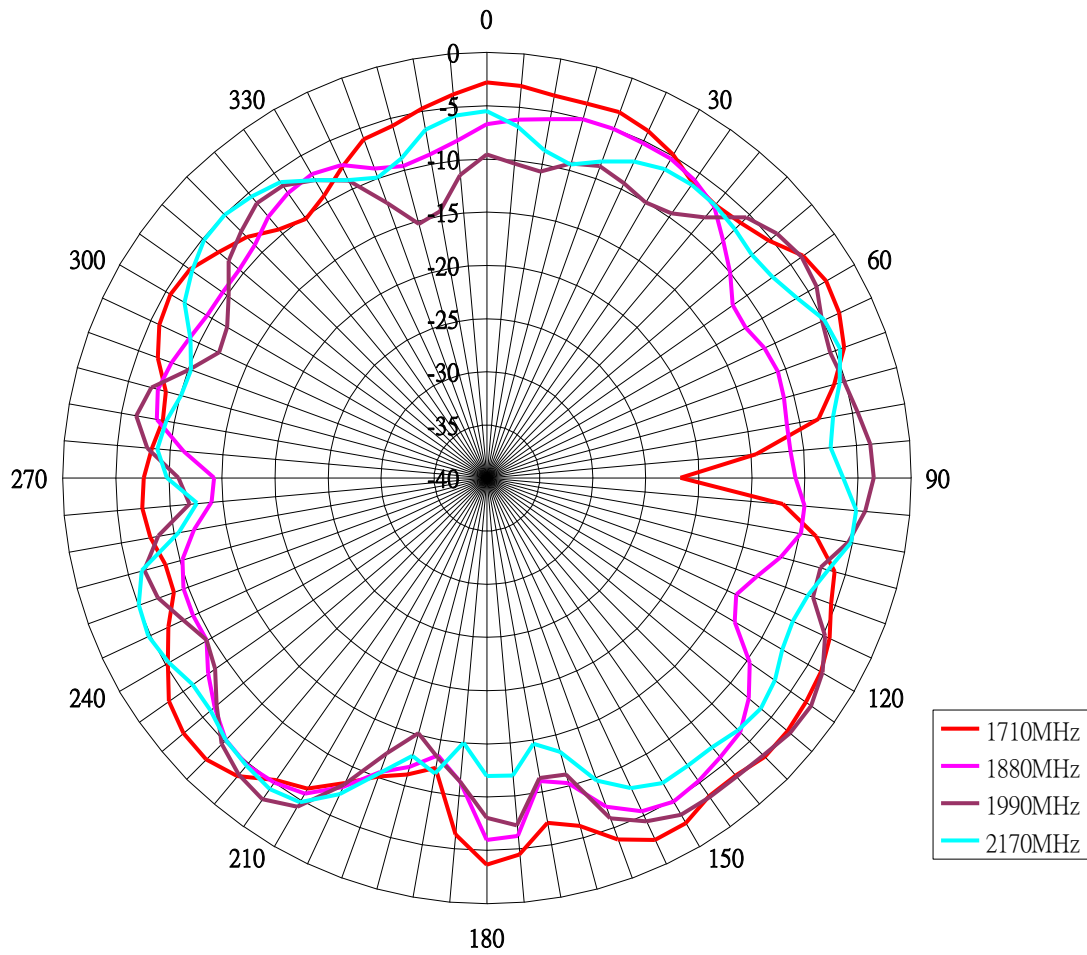

## 5.2.2 YZ Plane

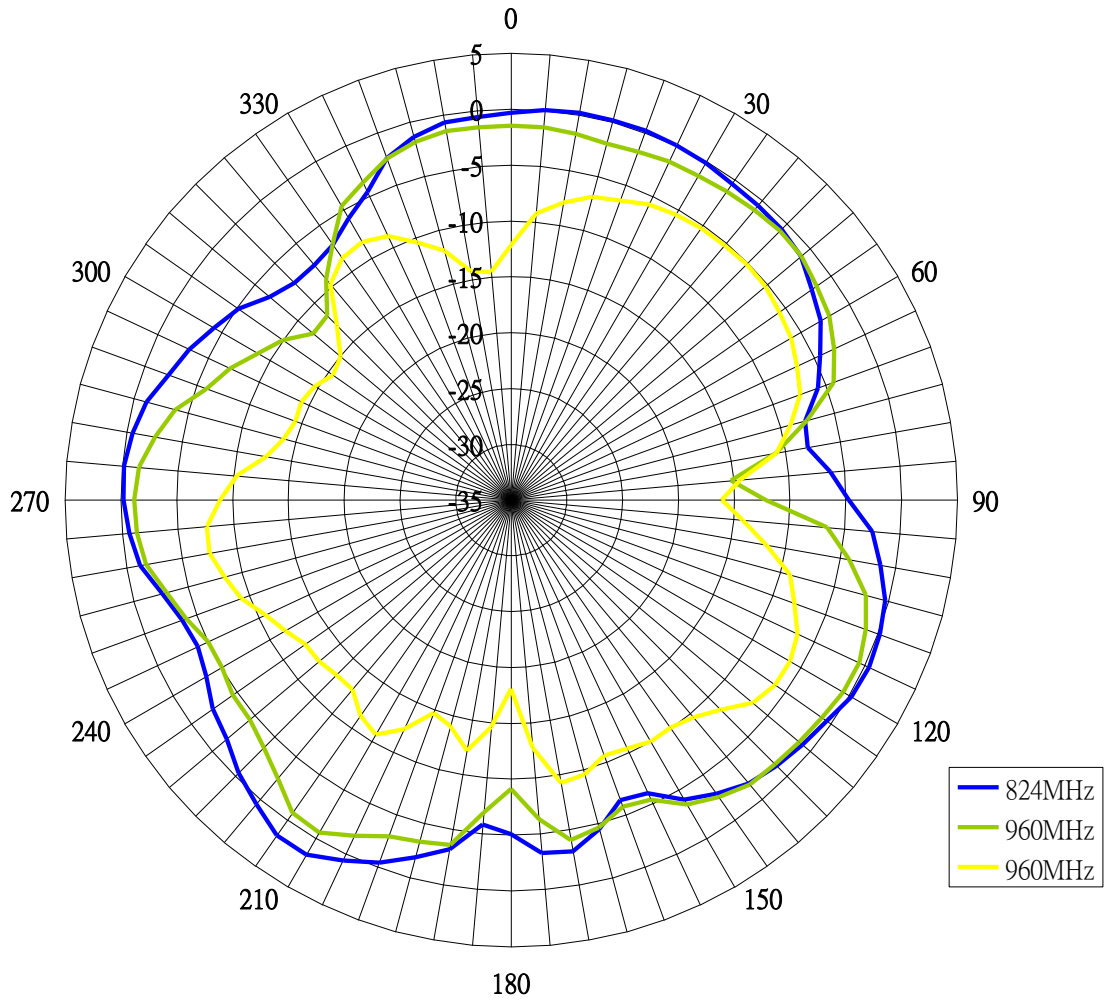



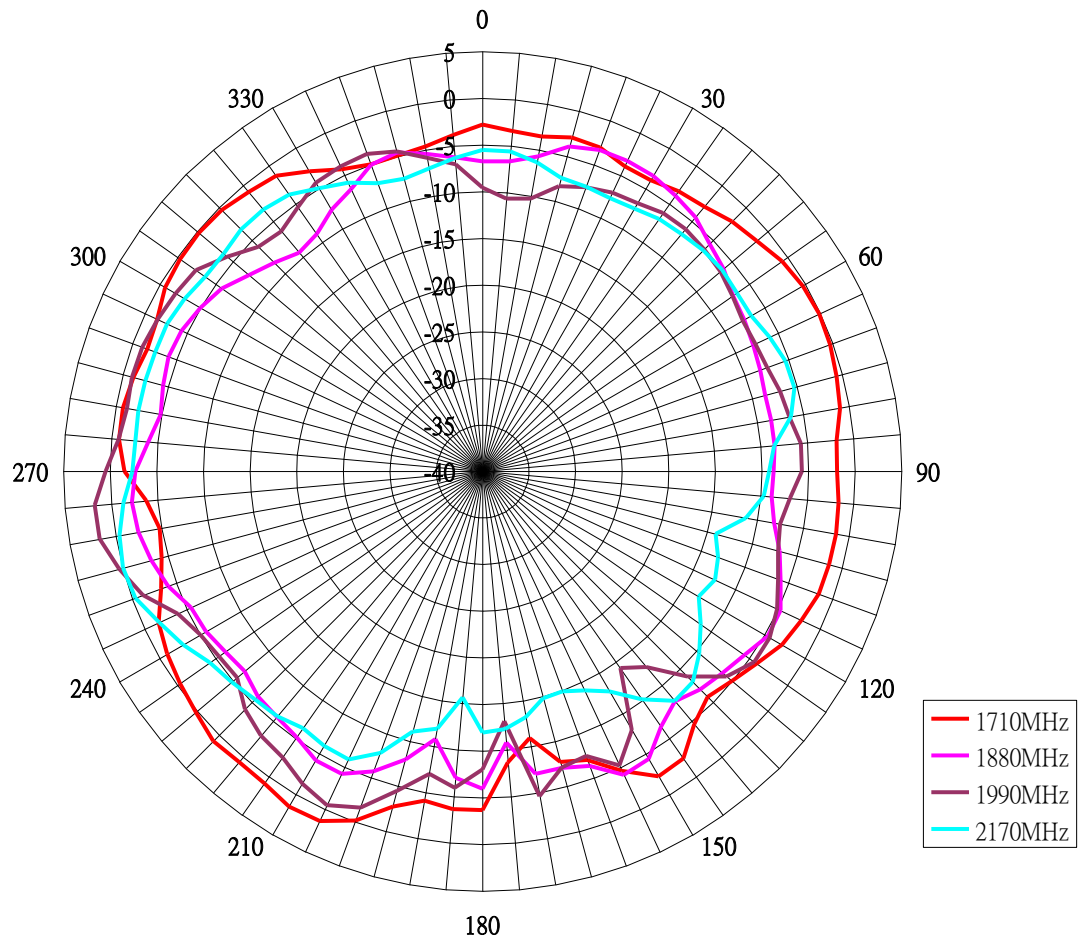

### 5.2.3 XY Plane

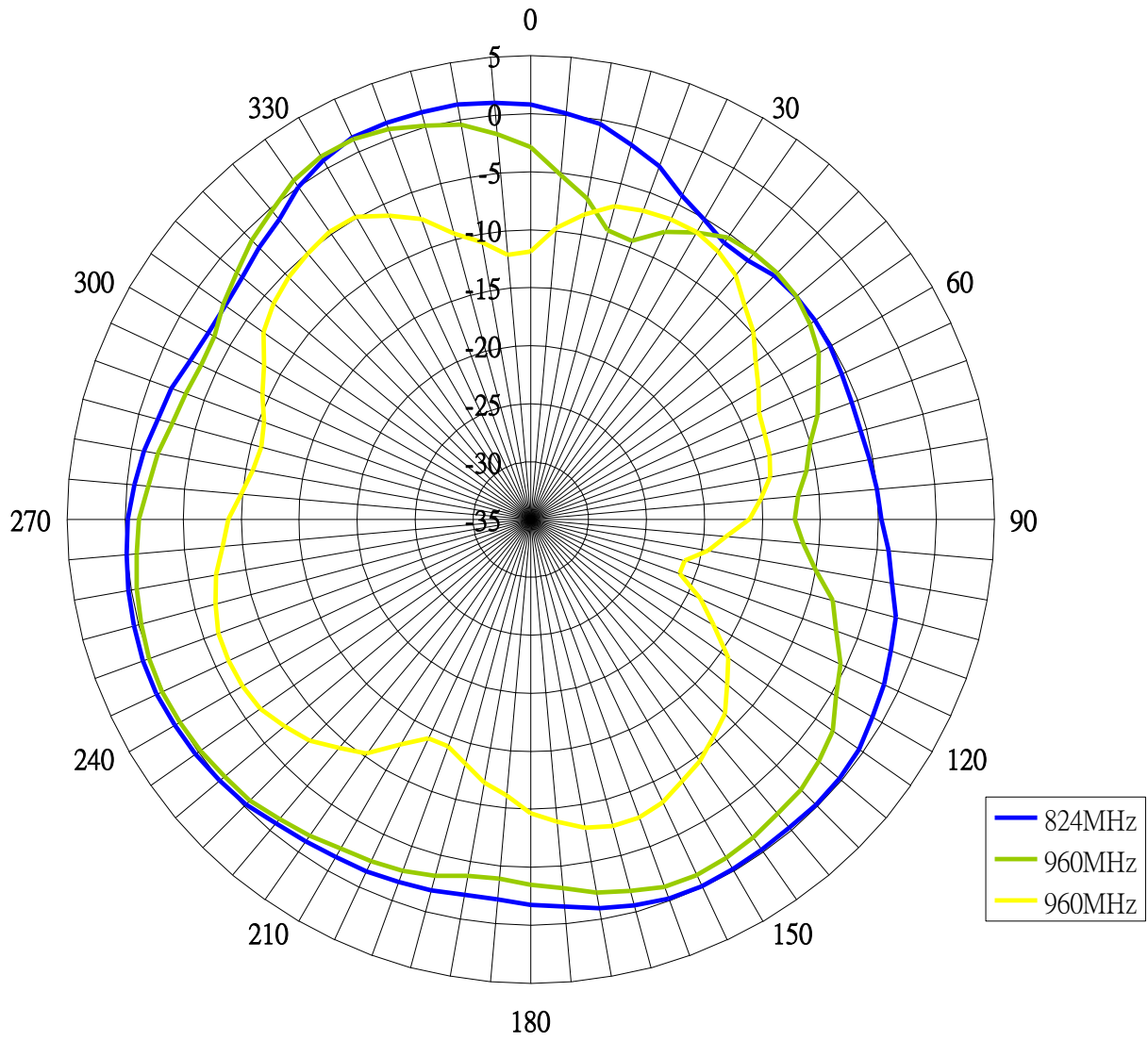

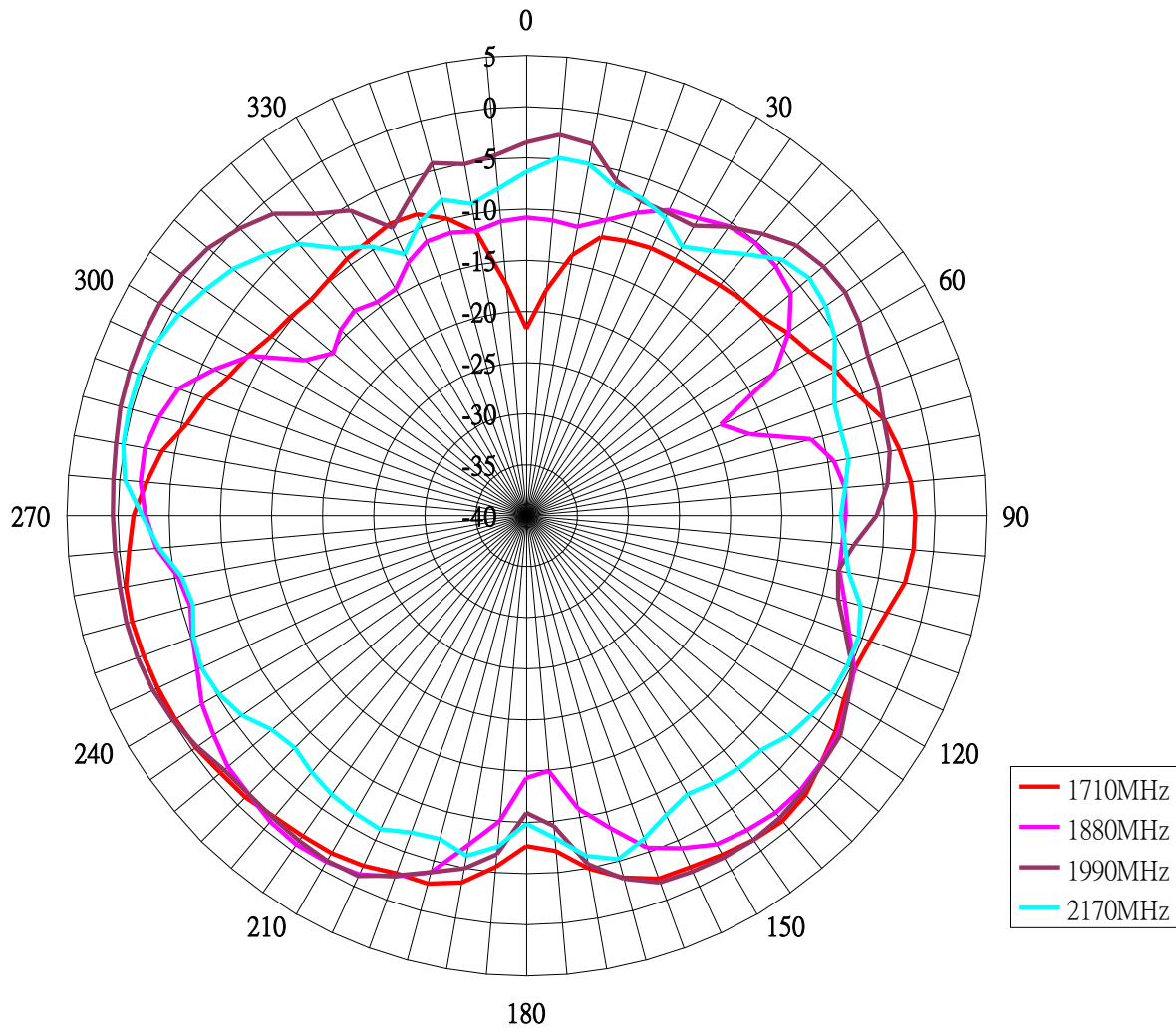

## 6 Mechanical Drawings

### 6.1 Unit

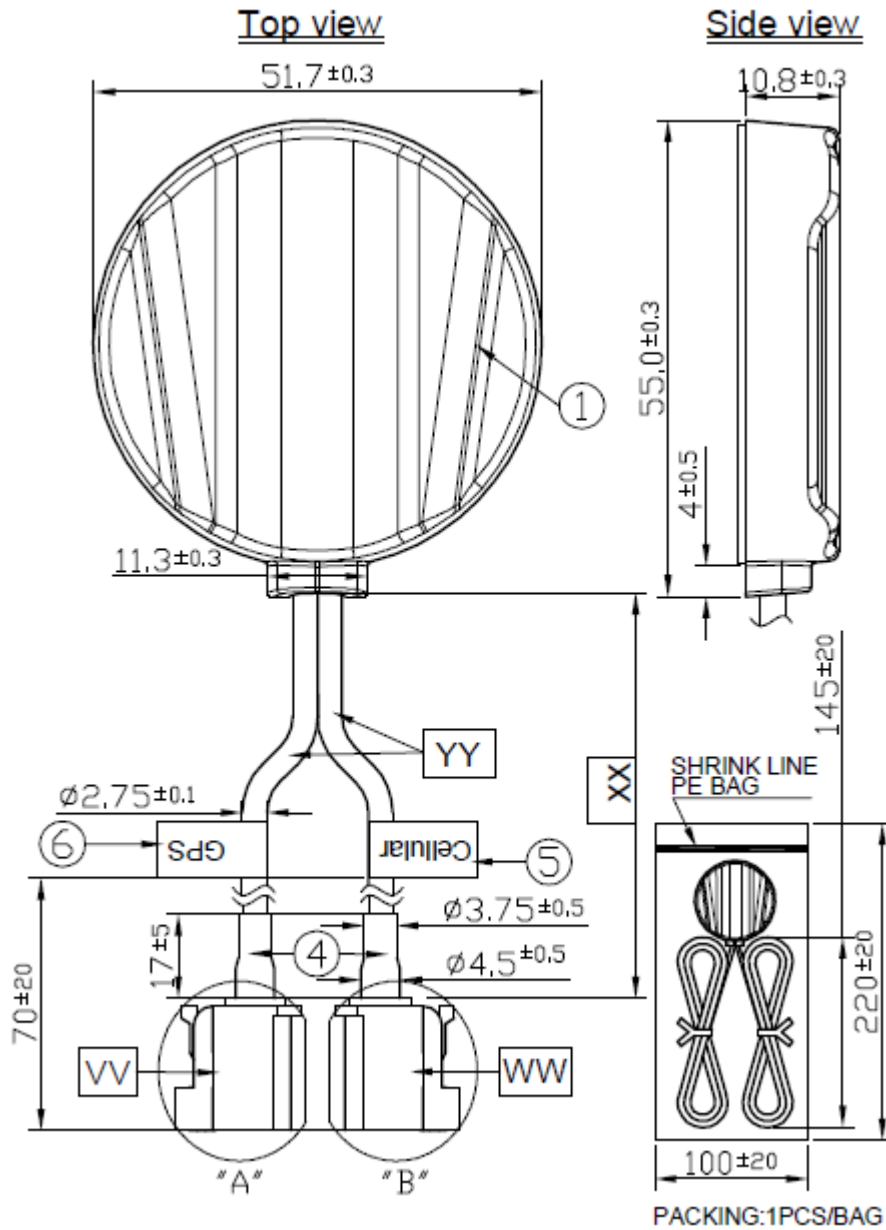

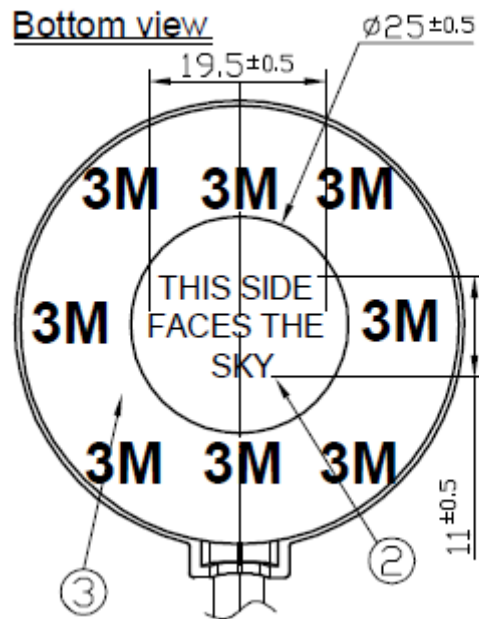

FAKRA .G2.SMB.F.ST.C.B.AM

FAKRA.G2.SMB.F.ST.D.V.AM

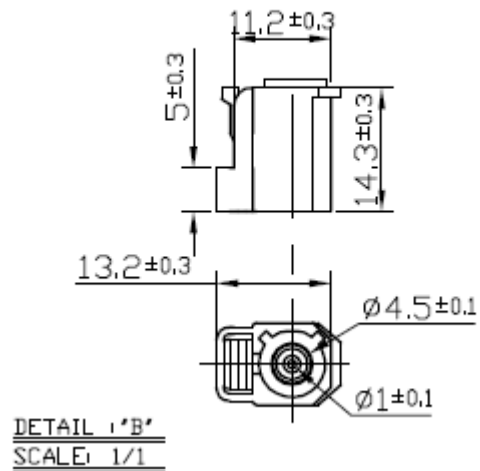
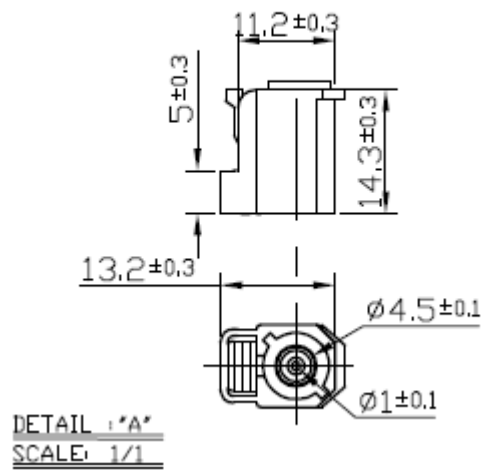

	Name	Material	Finish	QTY
1	Housing	ABS	Black	1
2	Round Label	Art Paper	White	1
3	Scotch Brand Acrylic Foam Tape	3M 4612	White Liner	1
4	Heat Shrink tube	PE	Black	2
5	Cellular Label	Coated Paper	Blue	1
6	GPS Label	Coated Paper	Orange	1

	Name	Spec	Finish	QTY
WV	Connector Type	FAKRA Code C GEN2	Blue	1
WW	Connector Type	FAKRA Code D GEN2	Violet	1
XX	Cable Length	3000mm ±30mm	Black	1
YY	Cable Type	RG174	Black	2

## 6.2 Carton

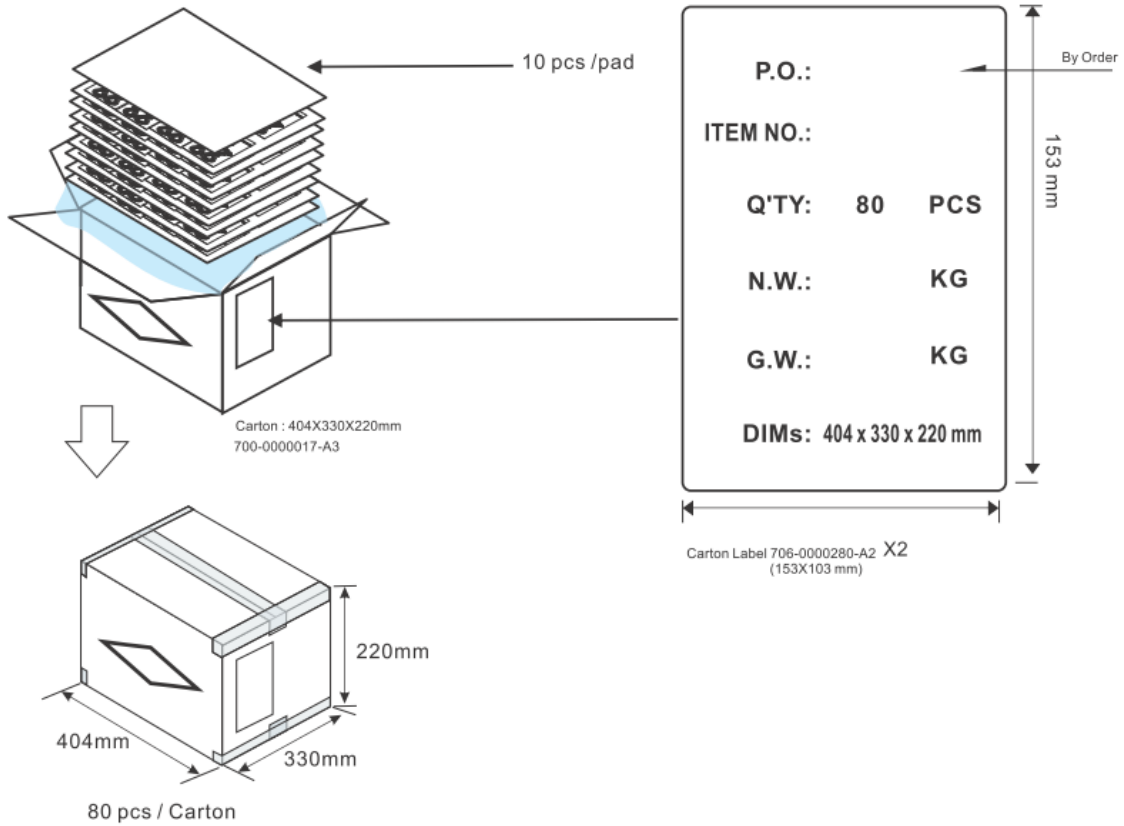



Компания «ЭлектроПласт» предлагает заключение долгосрочных отношений при поставках импортных электронных компонентов на взаимовыгодных условиях!

Наши преимущества:

- Оперативные поставки широкого спектра электронных компонентов отечественного и импортного производства напрямую от производителей и с крупнейших мировых складов;
- Поставка более 17-ти миллионов наименований электронных компонентов;
- Поставка сложных, дефицитных, либо снятых с производства позиций;
- Оперативные сроки поставки под заказ (от 5 рабочих дней);
- Экспресс доставка в любую точку России;
- Техническая поддержка проекта, помощь в подборе аналогов, поставка прототипов;
- Система менеджмента качества сертифицирована по Международному стандарту ISO 9001;
- Лицензия ФСБ на осуществление работ с использованием сведений, составляющих государственную тайну;
- Поставка специализированных компонентов (Xilinx, Altera, Analog Devices, Intersil, Interpoint, Microsemi, Aeroflex, Peregrine, Syfer, Eurofarad, Texas Instrument, Miteq, Cobham, E2V, MA-COM, Hittite, Mini-Circuits, General Dynamics и др.);

Помимо этого, одним из направлений компании «ЭлектроПласт» является направление «Источники питания». Мы предлагаем Вам помощь Конструкторского отдела:

- Подбор оптимального решения, техническое обоснование при выборе компонента;
- Подбор аналогов;
- Консультации по применению компонента;
- Поставка образцов и прототипов;
- Техническая поддержка проекта;
- Защита от снятия компонента с производства.



#### Как с нами связаться

**Телефон:** 8 (812) 309 58 32 (многоканальный)

**Факс:** 8 (812) 320-02-42

**Электронная почта:** [org@eplast1.ru](mailto:org@eplast1.ru)

**Адрес:** 198099, г. Санкт-Петербург, ул. Калинина, дом 2, корпус 4, литера А.