

# Customer Information Sheet

DRAWING No.: M80-5000000M7-XX-XXX-00-000

SHEET 4 OF 6

IF IN DOUBT - ASK

©

NOT TO SCALE

THIRD ANGLE PROJECTION

ALL DIMENSIONS IN mm

## SPECIFICATIONS:

### MATERIAL:

MOULDING: GLASS FILLED PPS, UL94V-0, BLACK

### COAX CONTACT:

BODY, SLEEVE, INNER CONTACT,  
END PLUG = COPPER ALLOY  
LATCHING COLLAR = BERYLLIUM COPPER  
INSULATOR = PTFE  
BOARD MOUNT JACKSCREW, SCREW = STAINLESS STEEL

### FINISH:

COAX CONTACT:  
BODY, SLEEVE, INNER CONTACT, END PLUG = GOLD  
LATCHING COLLAR = NICKEL

### ELECTRICAL:

WORKING VOLTAGE = 800V AC/DC

VOLTAGE PROOF = 1200V AC/DC

INSULATION RESISTANCE = 100MΩ MIN

### COAX CONTACT:

FREQUENCY RANGE = 6GHz

IMPEDANCE = 50Ω

V.S.W.R = 1.05 + (0.04 x FREQUENCY) GHz MAX

CONTACT RESISTANCE = 6mΩ MAX

INSULATION RESISTANCE = 10<sup>6</sup>MΩ @250V AC

OPERATING VOLTAGE = 180V AC @ 500mA

MAXIMUM VOLTAGE = 1000V AC

### MECHANICAL:

DURABILITY = 500 OPERATIONS

### COAX CONTACT:

INSERTION FORCE = 8N MAX

WITHDRAWAL FORCE = 0.5N MIN

### ENVIRONMENTAL:

TEMPERATURE RANGE = -55°C TO +125°C

### PACKING:

BAG

FOR COMPLETE SPECIFICATION SEE COMPONENT SPECIFICATION C005XX (LATEST ISSUE)

## COAX CRIMP CONTACTS ONLY

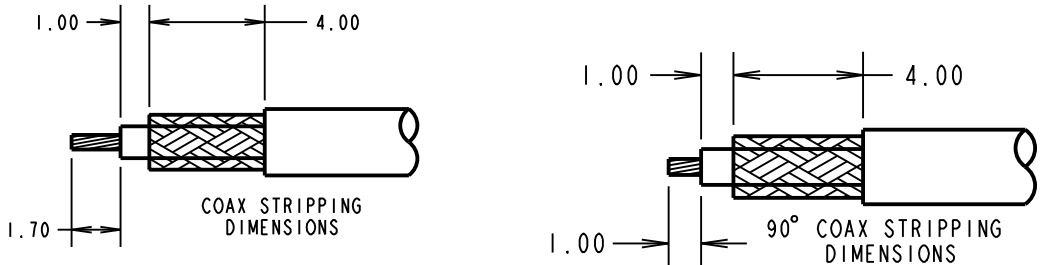
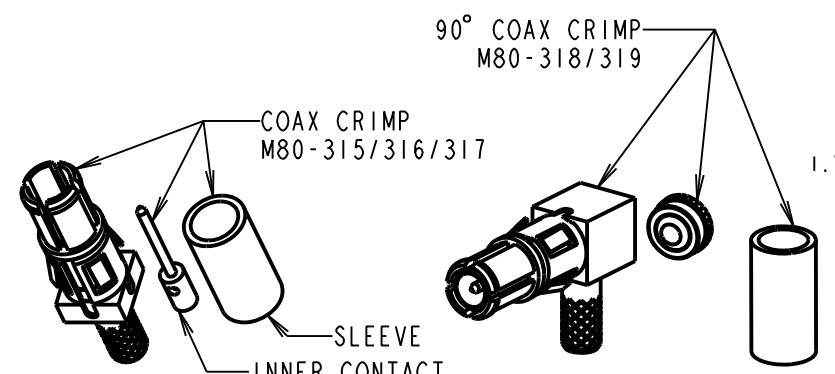
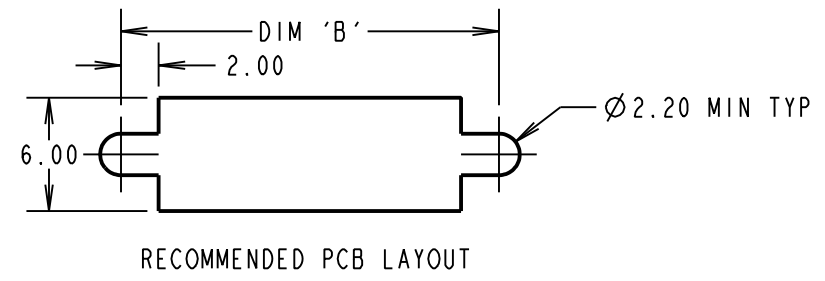
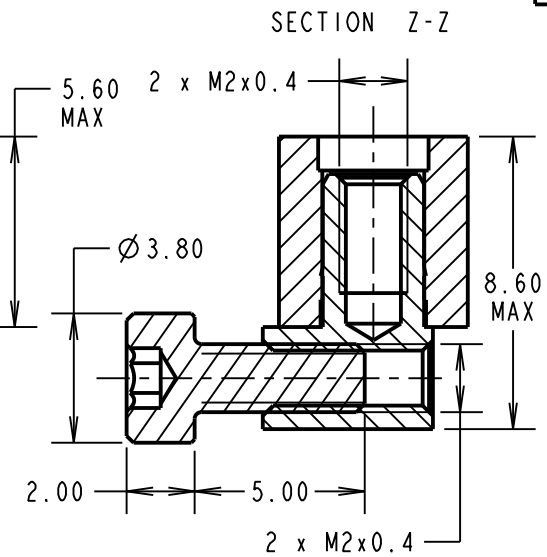
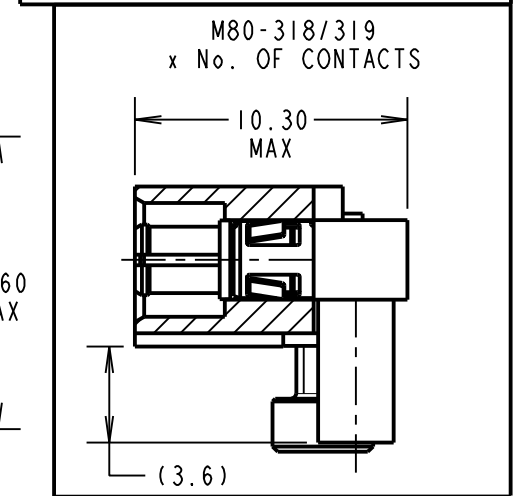
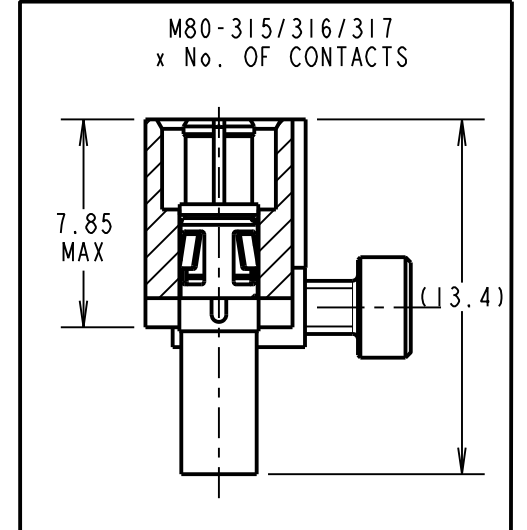
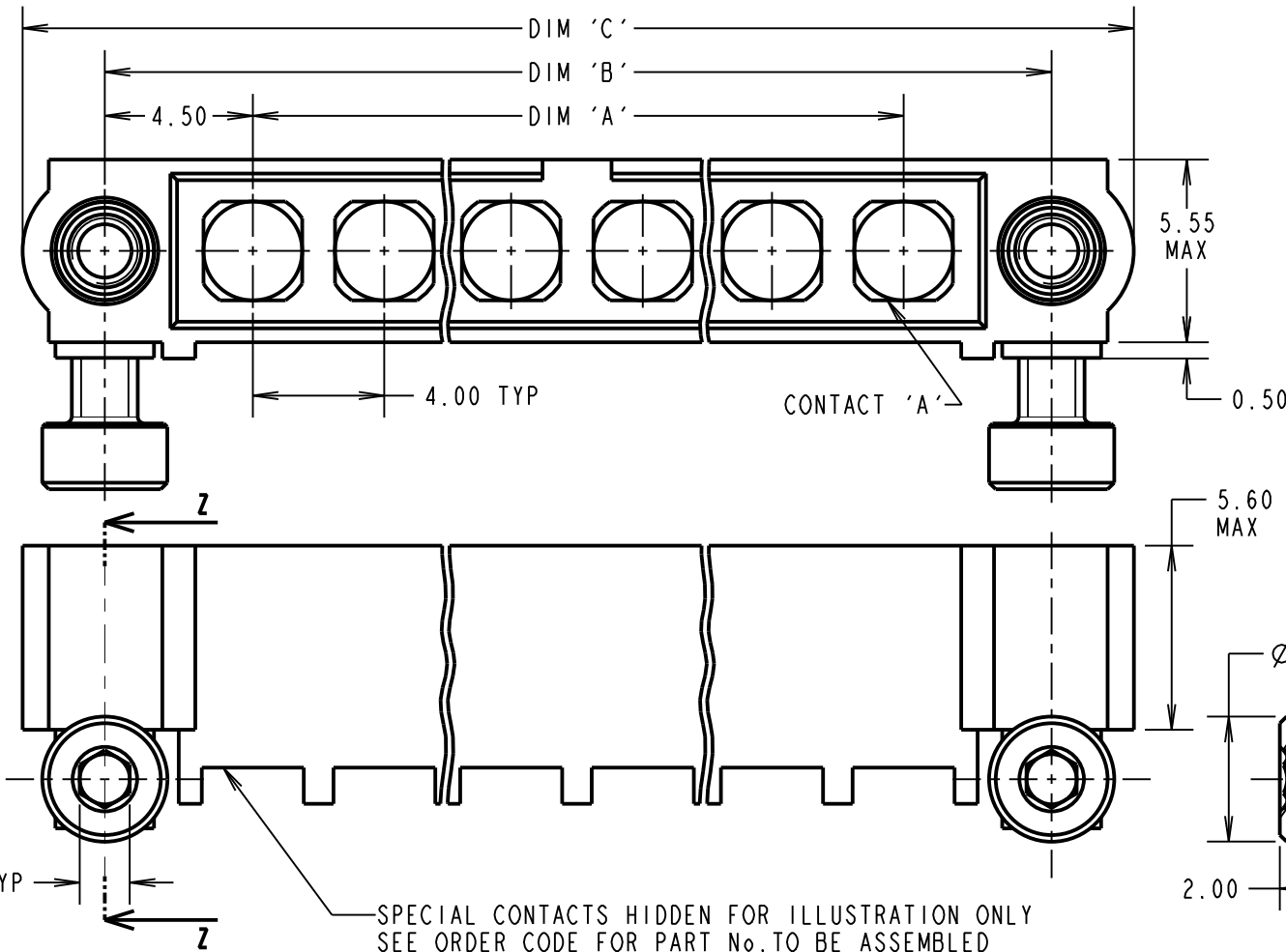

### CRIMP/SOLDER NOTES:

- CONNECTORS ARE SUPPLIED WITH CONTACTS LOOSE.
- COAX CONTACT IS SUPPLIED AS A KIT OF PARTS: BODY, MAIN INSULATOR, INNER CONTACT AND LATCHING COLLAR ARE PRE-ASSEMBLED AND SLEEVE AND INSULATED END PLUG ASSEMBLY ARE SEPARATE.
- FOR EXTRA COAX CONTACTS, USE PART NUMBERS M80-315/316/317/318/319.
- COAX CONTACT EXTRACTION TOOL = Z80-290.
- RECOMMENDED HAND CRIMP TOOL FOR INNER COAX CONTACT = Z80-292 WITH POSITIONER Z80-291. RECOMMENDED HAND CRIMP TOOL AND DIE SET FOR SLEEVE = Z80-293.
- INSTRUCTION SHEETS ARE AVAILABLE.

ORDER CODE: (COAX CRIMP CONTACTS)  
**M80-5000000M7-XX-XXX-00-000**

TOTAL No. OF CONTACTS \_\_\_\_\_  
02 TO 12

SPECIAL CONTACTS \_\_\_\_\_  
315 = COAX CONTACT 2.00mm CRIMP M80-315  
316 = COAX CONTACT 2.40mm CRIMP M80-316  
317 = COAX CONTACT 2.70mm CRIMP M80-317  
318 = COAX CONTACT 2.00mm HORIZ' CRIMP M80-318  
319 = COAX CONTACT 2.70mm HORIZ' CRIMP M80-319

MSP	3	23.02.15	12566
NAME	ISS.	DATE	C/NOTE
APPROVED:		M.PERREN	
CHECKED:		S.BENNETT	
DRAWN:		S.MCCULLAGH	
CUSTOMER REF.:			
ASSEMBLY DRG:			

DIMENSION	CALCULATION
DIM 'A'	4 x No. OF CONTACTS - 4.00
DIM 'B'	4 x No. OF CONTACTS + 5.00
DIM 'C'	4 x No. OF CONTACTS + 10.00

EXAMPLE 1: CONNECTOR WITH 08 COAX CONTACTS,  
M80-5000000M7-08-315-00-000  
DIM 'A' = 28.00mm, DIM 'B' = 37.00mm, DIM 'C' = 42.00mm

**HARWIN**

www.harwin.com  
technical@harwin.com

THIS DRAWING AND ANY INFORMATION OR DESCRIPTIVE MATTER SET OUT HEREON ARE CONFIDENTIAL AND COPYRIGHT PROPERTY OF THE HARWIN GROUP AND MUST NOT BE DISCLOSED, LOANED, COPIED OR USED FOR MANUFACTURING, TENDERING OR FOR ANY OTHER PURPOSE WITHOUT THEIR WRITTEN PERMISSION.

TOLERANCES  
X. = ±1mm  
X.X = ±0.50mm  
X.XX = ±0.10mm  
X.XXX = ±0.01mm  
ANGLES = ±5°  
UNLESS STATED

MATERIAL: SEE ABOVE  
FINISH: SEE ABOVE  
S/AREA: mm<sup>2</sup>

TITLE: DATAMATE MIX-TEK MALE ASSY WITH HEX SOCKET BOARDMOUNT J/SCREW  
DRAWING NUMBER: **M80-5000000M7-XX-XXX-00-000**  
SHT 4 OF 6

# Customer Information Sheet

DRAWING No.: M80-500000M7-XX-XXX-00-000

SHEET 5 OF 6

IF IN DOUBT - ASK

©

NOT TO SCALE

THIRD ANGLE PROJECTION

ALL DIMENSIONS IN mm

**SPECIFICATIONS:**

**MATERIAL:**  
 MOULDING: GLASS FILLED PPS, UL94V-0, BLACK  
**POWER CONTACT:**  
 BODY, SLEEVE, INNER CONTACT, END PLUG = COPPER ALLOY  
 LATCHING COLLAR = BERYLLIUM COPPER  
 INSULATOR = PTFE  
 BOARD MOUNT JACKSCREW, SCREW = STAINLESS STEEL  
**FINISH:**  
**POWER CONTACT:**  
 BODY, SLEEVE, INNER CONTACT, END PLUG = GOLD  
 LATCHING COLLAR = NICKEL  
**ELECTRICAL:**  
 WORKING VOLTAGE = 800V AC/DC  
 VOLTAGE PROOF = 1200V AC/DC  
 INSULATION RESISTANCE = 100MΩ MIN  
**POWER CONTACT:**  
 CONTACT RESISTANCE = 6mΩ MAX  
 CURRENT RATING = M80-335 = 20A MAX WITH 12AWG  
 M80-336 = 15A MAX WITH 14AWG  
 M80-337 = 10A MAX WITH 16AWG  
 M80-338 = 8A MAX WITH 18AWG  
 M80-339 = 5A MAX WITH 20AWG  
 M80-PM5 = 40A MAX WITH 10AWG  
 CONTACT AS SPECIFIED

**MECHANICAL:**  
 DURABILITY = 500 OPERATIONS  
**POWER CONTACT:**  
 INSERTION FORCE:  
 M80-335/336/337/338/339 = 8N MAX  
 M80-PM5 = 15N MAX  
 WITHDRAWAL FORCE = 0.5N MIN  
**ENVIRONMENTAL:**  
 TEMPERATURE RANGE:  
 M80-335/336/337/338/339 = -55°C TO +125°C  
 M80-PM5 = -55°C TO +150°C  
**PACKING:**  
 BAG  
 FOR COMPLETE SPECIFICATION SEE COMPONENT SPECIFICATION C005XX (LATEST ISSUE)

## POWER CRIMP & SOLDER CONTACTS ONLY

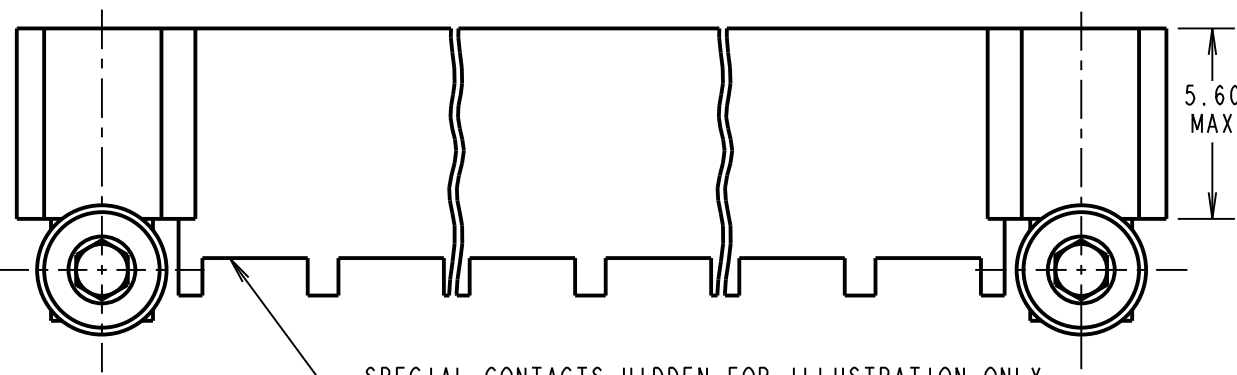
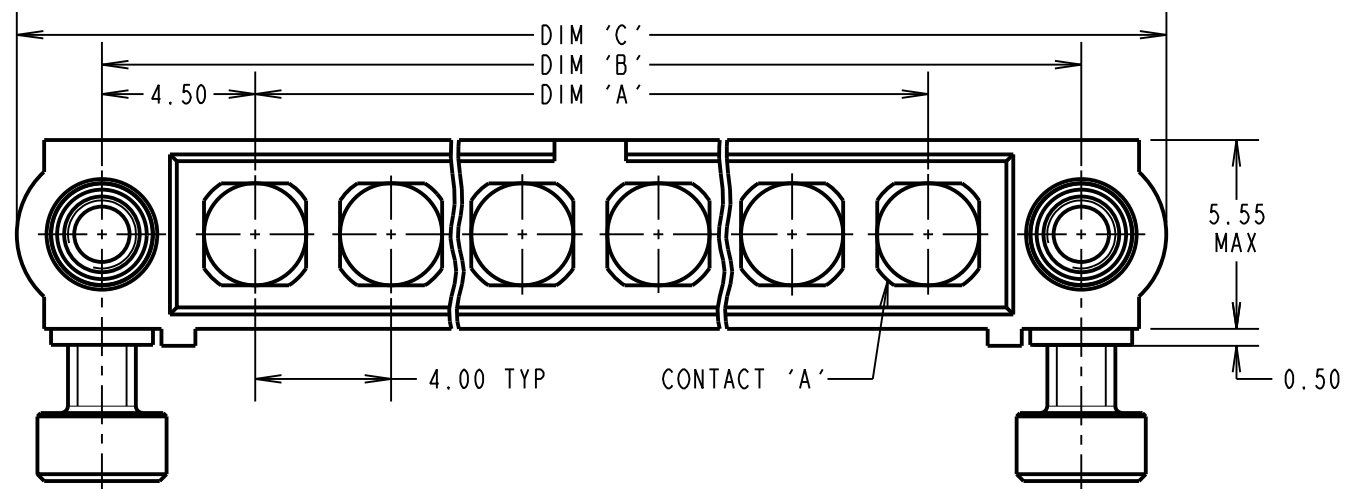

SPECIAL CONTACTS HIDDEN FOR ILLUSTRATION ONLY  
 SEE ORDER CODE FOR PART No. TO BE ASSEMBLED

**RECOMMENDED PCB LAYOUT**

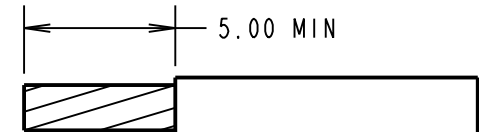
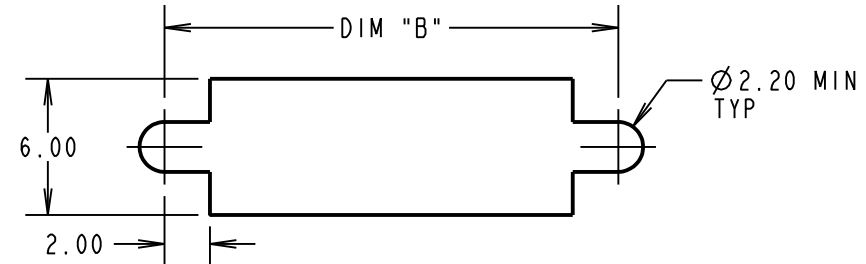

POWER CABLE STRIPPING DIMENSIONS

**CRIMP/SOLDER NOTES:**

- CONNECTORS ARE SUPPLIED WITH CONTACTS LOOSE.
- FOR EXTRA POWER CONTACTS USE PART NUMBERS M80-335/336/337/338/339/PM5.
- POWER CONTACT EXTRACTION TOOL = Z80-290.
- RECOMMENDED HAND CRIMP TOOL FOR CONTACTS 338/339 = Z80-294 AND POSITIONER Z80-295.
- INSTRUCTION SHEETS ARE AVAILABLE.

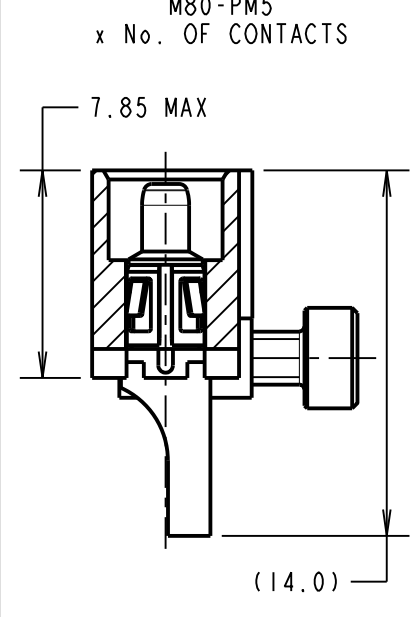
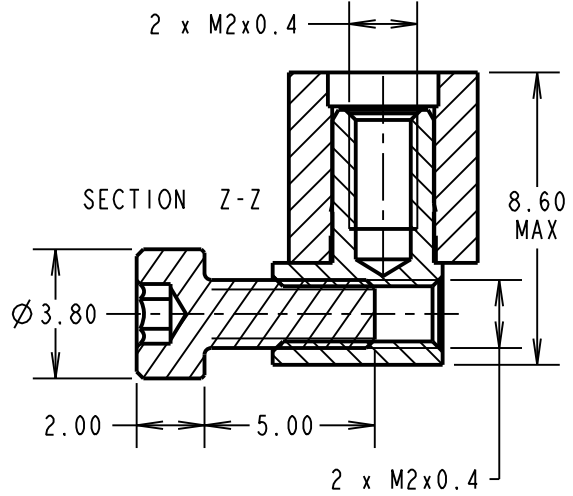
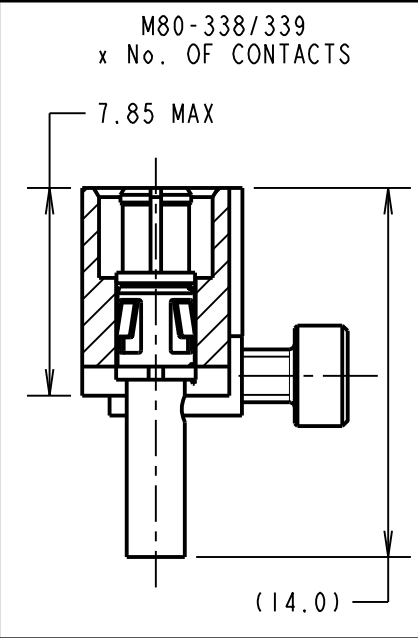
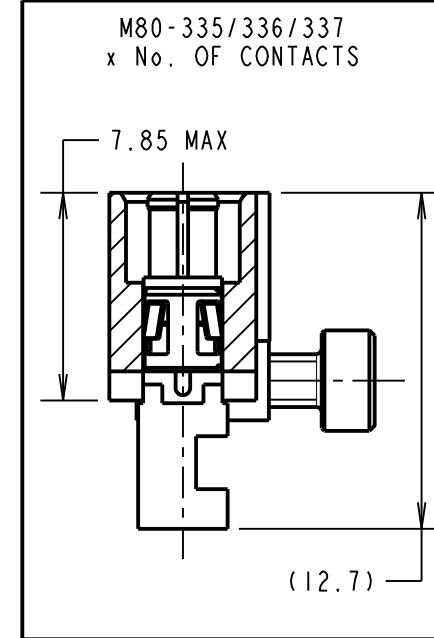

ORDER CODE: (POWER CRIMP/SOLDER CONTACTS)  
**M80-500000M7-XX-XXX-00-000**

TOTAL No. OF CONTACTS \_\_\_\_\_  
 02 TO 12

SPECIAL CONTACTS \_\_\_\_\_  
 335 = POWER CONTACT 12AWG SOLDER M80-335  
 336 = POWER CONTACT 14AWG SOLDER M80-336  
 337 = POWER CONTACT 16AWG SOLDER M80-337  
 338 = POWER CONTACT 18AWG SOLDER/CRIMP M80-338  
 339 = POWER CONTACT 20AWG SOLDER/CRIMP M80-339  
 PM5 = POWER CONTACT 10AWG SOLDER M80-PM5

MSP	3	23.02.15	12566
NAME	ISS.	DATE	C/NOTE
APPROVED:		M.PERREN	
CHECKED:		S.BENNETT	
DRAWN:		S.MCCULLAGH	
CUSTOMER REF.:			
ASSEMBLY DRG:			

DIMENSION	CALCULATION
DIM 'A'	4 x No. OF CONTACTS - 4.00
DIM 'B'	4 x No. OF CONTACTS + 5.00
DIM 'C'	4 x No. OF CONTACTS + 10.00

EXAMPLE 2: CONNECTOR WITH 10 POWER CONTACTS,  
 M80-500000M7-10-335-00-000  
 DIM 'A' = 36.00mm, DIM 'B' = 45.00mm, DIM 'C' = 50.00mm

**HARWIN**

www.harwin.com  
 technical@harwin.com

THIS DRAWING AND ANY INFORMATION OR DESCRIPTIVE MATTER SET OUT HEREON ARE CONFIDENTIAL AND COPYRIGHT PROPERTY OF THE HARWIN GROUP AND MUST NOT BE DISCLOSED, LOANED, COPIED OR USED FOR MANUFACTURING, TENDERING OR FOR ANY OTHER PURPOSE WITHOUT THEIR WRITTEN PERMISSION.

**TOLERANCES**  
 X. = ±1mm  
 X.X = ±0.50mm  
 X.XX = ±0.10mm  
 X.XXX = ±0.01mm  
**ANGLES = ±5°**  
 UNLESS STATED

**MATERIAL:**  
 SEE ABOVE  
**FINISH:** SEE ABOVE  
**S/AREA:** mm<sup>2</sup>

**TITLE:** DATAMATE MIX-TEK MALE ASSY WITH HEX SOCKET BOARDMOUNT J/SCREW  
**DRAWING NUMBER:** M80-500000M7-XX-XXX-00-000  
 SHT 5 OF 6

# Customer Information Sheet

DRAWING No.: M80-500000M7-XX-XXX-00-000

SHEET 6 OF 6

IF IN DOUBT - ASK

©

NOT TO SCALE

THIRD ANGLE PROJECTION

ALL DIMENSIONS IN mm

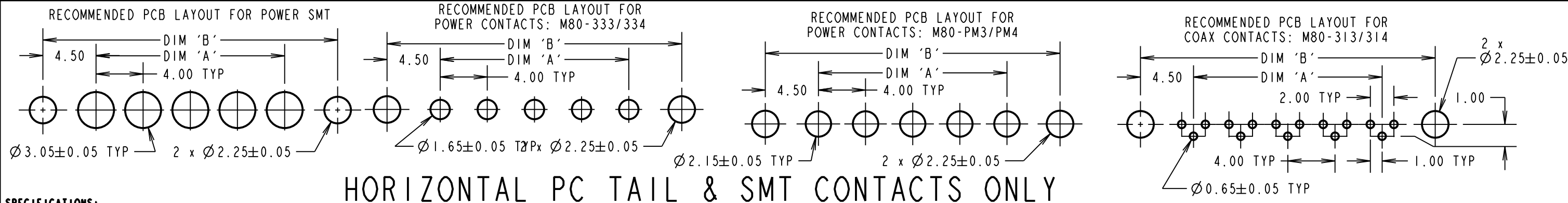

## HORIZONTAL PC TAIL & SMT CONTACTS ONLY

### SPECIFICATIONS:

- MATERIAL:**  
 MOULDING: GLASS FILLED PPS, UL94V-0, BLACK  
 POWER CONTACT: COPPER ALLOY  
 COAX CONTACT:  
 BODY = COPPER ALLOY  
 INNER CONTACT = COPPER ALLOY  
 INSULATOR = PTFE  
 BOARD MOUNT JACKSCREW, SCREW: STAINLESS STEEL
- FINISH:**  
 POWER CONTACT: GOLD  
 COAX CONTACT: BODY, INNER CONTACT = GOLD
- ELECTRICAL:**  
 WORKING VOLTAGE = 800V AC/DC  
 VOLTAGE PROOF = 1200V AC/DC  
 INSULATION RESISTANCE = 100MΩ MIN  
 POWER CONTACT:  
 CONTACT RESISTANCE = 6mΩ MAX  
 CURRENT RATING:  
 M80-333/334/33A = 20A MAX  
 M80-PM3/PM4 = 40A MAX  
 COAX CONTACT:  
 FREQUENCY RANGE = 6GHz  
 IMPEDANCE = 50Ω  
 V.S.W.R = 1.05 + (0.04 x FREQUENCY) GHz MAX  
 CONTACT RESISTANCE = 6mΩ MAX  
 INSULATION RESISTANCE = 10<sup>6</sup>MΩ @250V AC  
 OPERATING VOLTAGE = 180V AC @ 500mA  
 MAXIMUM VOLTAGE = 1000V AC
- MECHANICAL:**  
 DURABILITY = 500 OPERATIONS  
 POWER CONTACT:  
 INSERTION FORCE:  
 M80-333/334/33A = 8N MAX  
 M80-PM3/PM4 = 15N MAX  
 WITHDRAWAL FORCE = 0.5N MIN  
 COAX CONTACT:  
 INSERTION FORCE = 8N MAX  
 WITHDRAWAL FORCE = 0.5N MIN
- ENVIRONMENTAL:**  
 TEMPERATURE RANGE:  
 M80-313/314/333/334/33A = -55°C TO +125°C  
 M80-PM3/PM4 = -55°C TO +125°C
- PACKING:**  
 TUBE  
 FOR COMPLETE SPECIFICATION SEE COMPONENT SPECIFICATION C005XX (LATEST ISSUE)

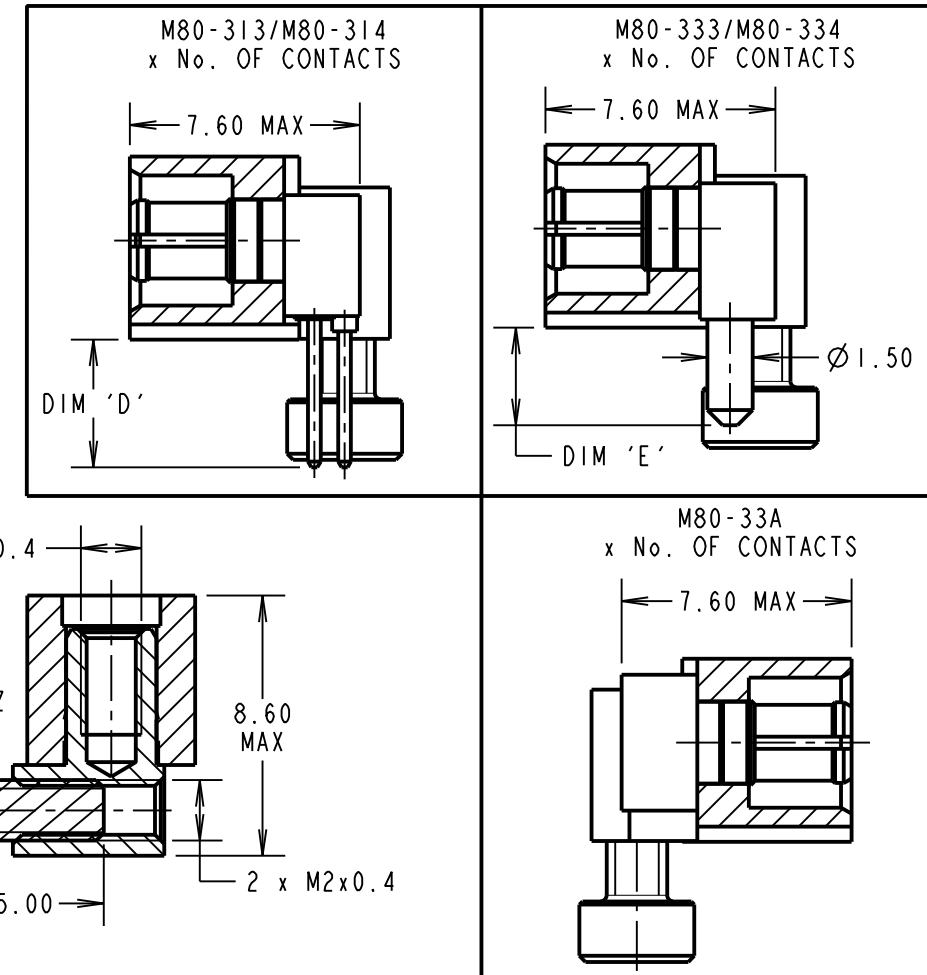
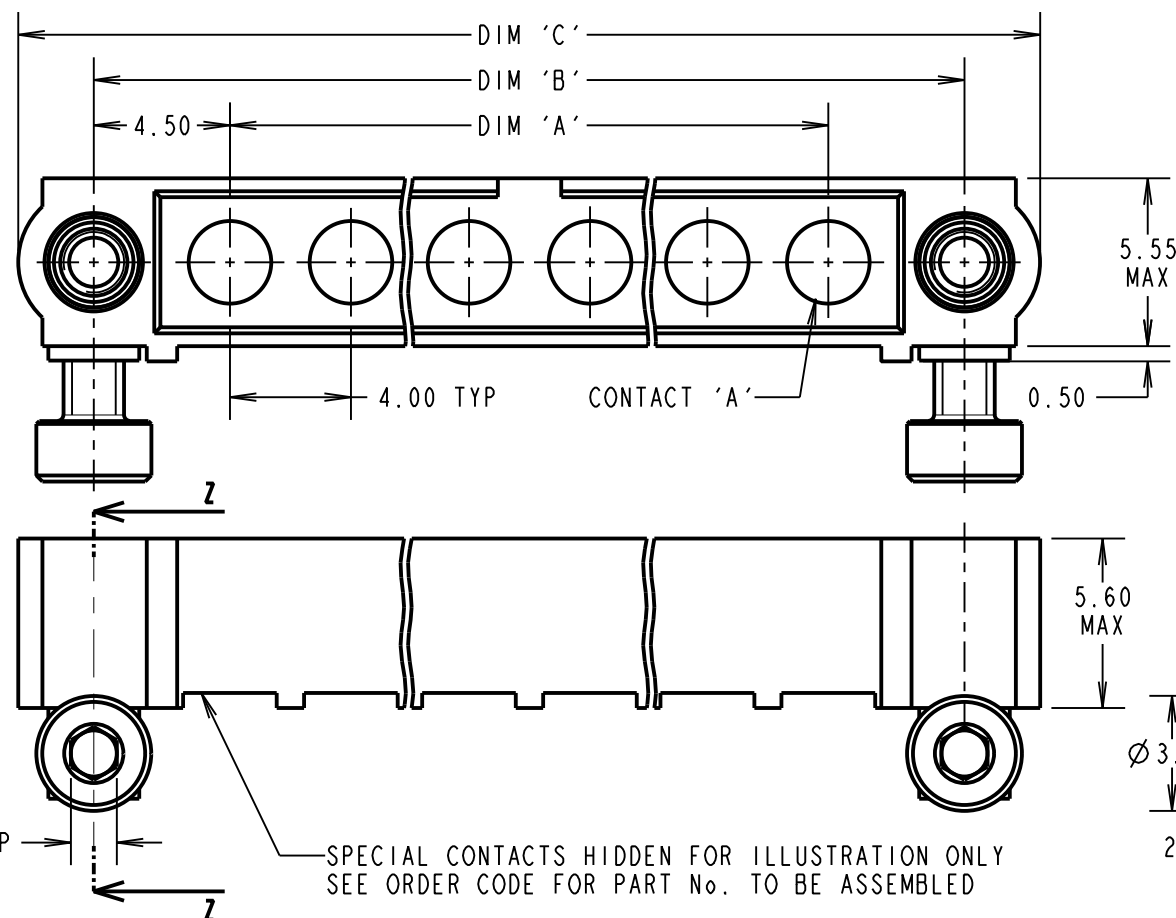

ORDER CODE: (PC TAIL CONTACTS ONLY)  
**M80-500000M7-XX-XXX-00-000**

- TOTAL No. OF CONTACTS  
 02 TO 12
- SPECIAL CONTACTS  
 313 = COAX CONTACT 3.0mm PC TAIL M80-313  
 314 = COAX CONTACT 4.5mm PC TAIL M80-314  
 333 = 20A POWER CONTACT 3.5mm HORZ' PC TAIL M80-333  
 334 = 20A POWER CONTACT 5.0mm HORZ' PC TAIL M80-334  
 PM3 = 40A POWER CONTACT 3.5mm HORZ' PC TAIL M80-PM3  
 PM4 = 40A POWER CONTACT 5.0mm HORZ' PC TAIL M80-PM4  
 33A = POWER CONTACT HORZ' SMT M80-33A

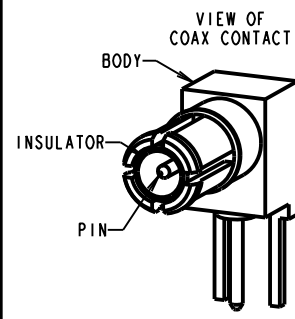

DIMENSION	CALCULATION
DIM 'A'	4 x No. OF CONTACTS - 4.00
DIM 'B'	4 x No. OF CONTACTS + 5.00
DIM 'C'	4 x No. OF CONTACTS + 10.00
DIM 'D'	M80-313 = 3.0mm, M80-314 = 4.5mm
DIM 'E'	M80-333 = 3.5mm, M80-334 = 5.0mm
DIM 'F'	M80-PM3 = 3.5mm, M80-PM4 = 5.0mm

EXAMPLE 2: CONNECTOR WITH 10 POWER CONTACTS,  
 M80-500000M7-10-333-00-000  
 DIM 'A' = 36.00mm, DIM 'B' = 45.00mm, DIM 'C' = 50.00mm  
 DIM 'E' = 3.5mm

**HARWIN**  
 www.harwin.com  
 technical@harwin.com

THIS DRAWING AND ANY INFORMATION OR DESCRIPTIVE MATTER SET OUT HEREON ARE CONFIDENTIAL AND COPYRIGHT PROPERTY OF THE HARWIN GROUP AND MUST NOT BE DISCLOSED, LOANED, COPIED OR USED FOR MANUFACTURING, TENDERING OR FOR ANY OTHER PURPOSE WITHOUT THEIR WRITTEN PERMISSION.

TOLERANCES  
 X. = ±1mm  
 X.X = ±0.50mm  
 X.XX = ±0.10mm  
 X.XXX = ±0.01mm  
 ANGLES = ±5°  
 UNLESS STATED

MATERIAL: SEE ABOVE  
 FINISH: SEE ABOVE  
 S/AREA: mm<sup>2</sup>

TITLE: DATAMATE MIX-TEK MALE ASSY WITH HEX SOCKET BOARDMOUNT J/SCREW  
 DRAWING NUMBER: **M80-500000M7-XX-XXX-00-000**  
 SHT 6 OF 6

MSP	3	23.02.15	12566
NAME	ISS.	DATE	C/NOTE
APPROVED:	M.PERREN		
CHECKED:	S.BENNETT		
DRAWN:	S.MCCULLAGH		
CUSTOMER REF.:			
ASSEMBLY DRG:			



Компания «ЭлектроПласт» предлагает заключение долгосрочных отношений при поставках импортных электронных компонентов на взаимовыгодных условиях!

Наши преимущества:

- Оперативные поставки широкого спектра электронных компонентов отечественного и импортного производства напрямую от производителей и с крупнейших мировых складов;
- Поставка более 17-ти миллионов наименований электронных компонентов;
- Поставка сложных, дефицитных, либо снятых с производства позиций;
- Оперативные сроки поставки под заказ (от 5 рабочих дней);
- Экспресс доставка в любую точку России;
- Техническая поддержка проекта, помощь в подборе аналогов, поставка прототипов;
- Система менеджмента качества сертифицирована по Международному стандарту ISO 9001;
- Лицензия ФСБ на осуществление работ с использованием сведений, составляющих государственную тайну;
- Поставка специализированных компонентов (Xilinx, Altera, Analog Devices, Intersil, Interpoint, Microsemi, Aeroflex, Peregrine, Syfer, Eurofarad, Texas Instrument, Miteq, Cobham, E2V, MA-COM, Hittite, Mini-Circuits, General Dynamics и др.);

Помимо этого, одним из направлений компании «ЭлектроПласт» является направление «Источники питания». Мы предлагаем Вам помощь Конструкторского отдела:

- Подбор оптимального решения, техническое обоснование при выборе компонента;
- Подбор аналогов;
- Консультации по применению компонента;
- Поставка образцов и прототипов;
- Техническая поддержка проекта;
- Защита от снятия компонента с производства.



#### Как с нами связаться

**Телефон:** 8 (812) 309 58 32 (многоканальный)

**Факс:** 8 (812) 320-02-42

**Электронная почта:** [org@eplast1.ru](mailto:org@eplast1.ru)

**Адрес:** 198099, г. Санкт-Петербург, ул. Калинина, дом 2, корпус 4, литера А.