

3M™ SHROUDED BOARDMOUNT HEADER, 1.27mm (0.050") PITCH
LATCH AND EJECT, 452 SERIES

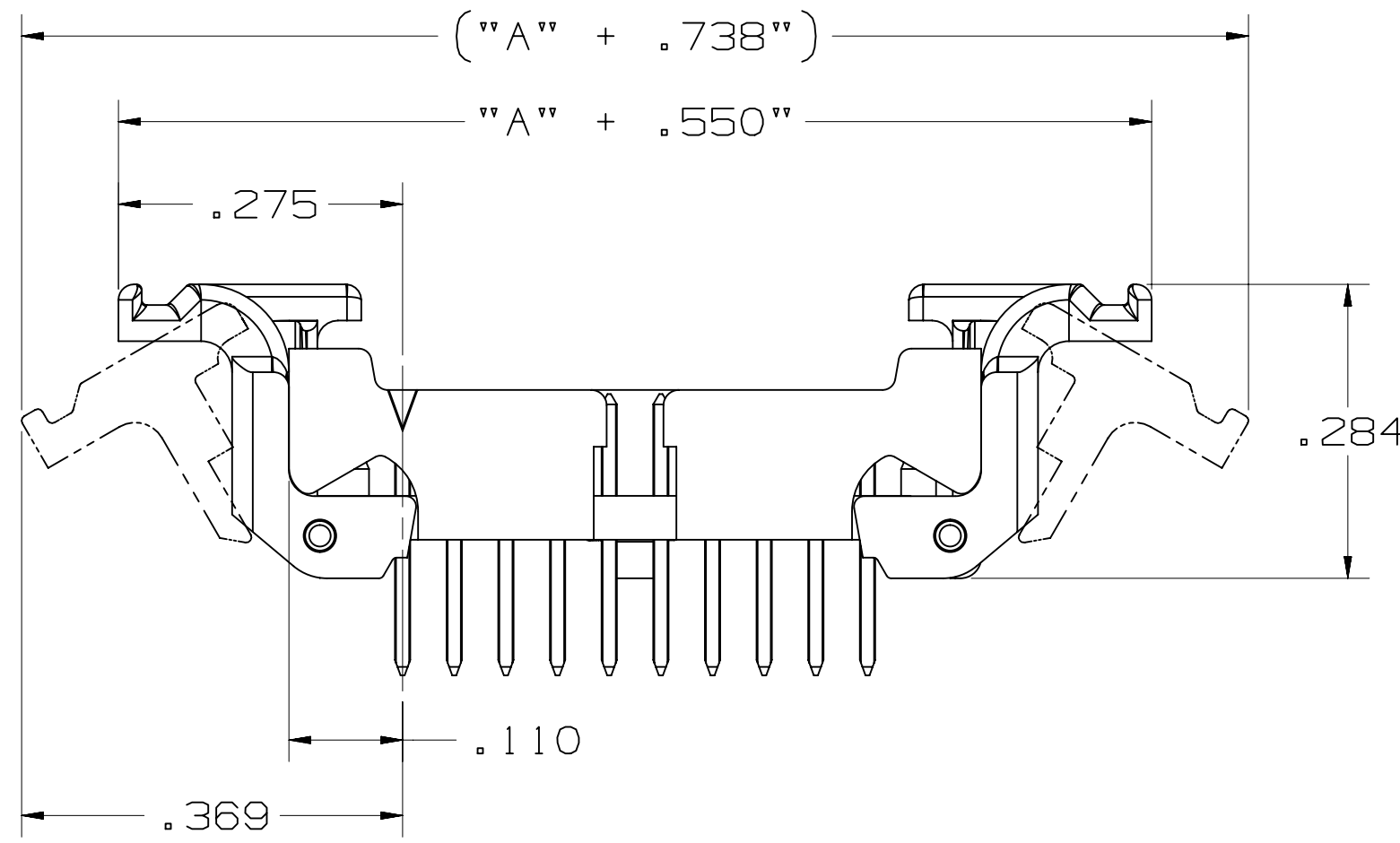
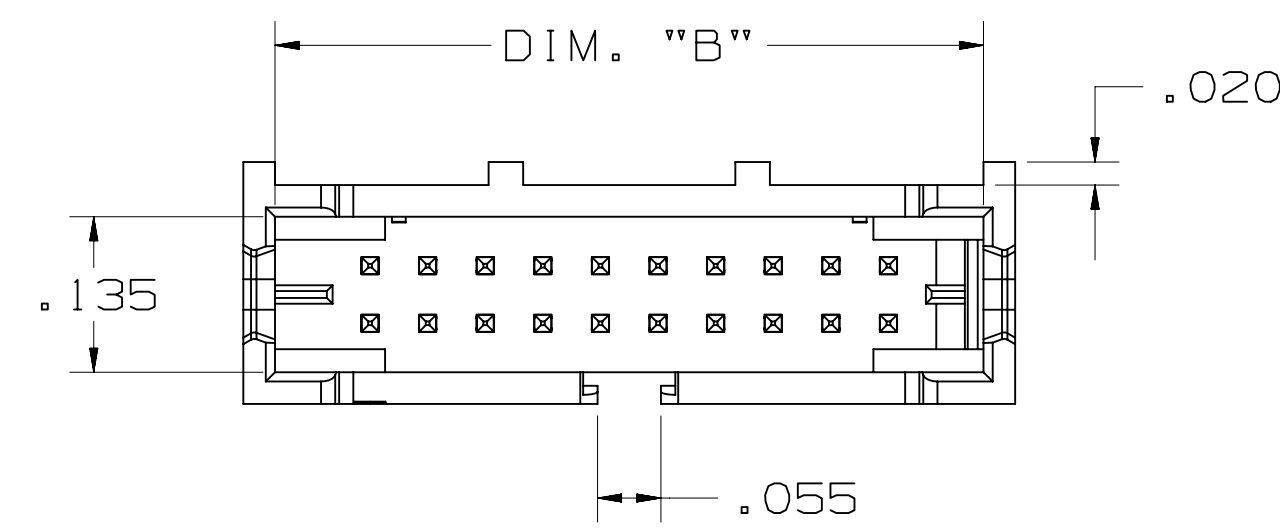
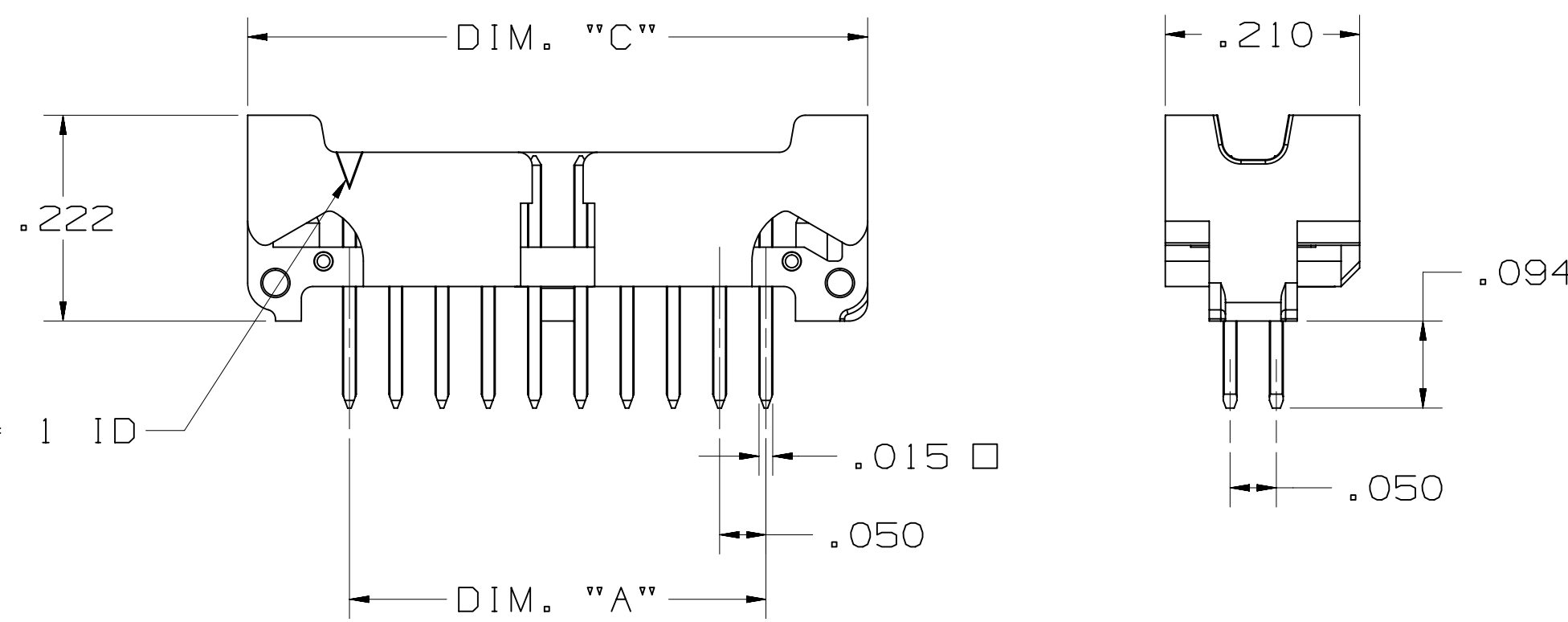

TABLE 1: VERTICAL THRU

No. Positions	Dim "A"	Dim "B"	Dim "C"
4	.050	.215	.270
6	.100	.265	.320
8	.150	.315	.370
10	.200	.365	.420
12	.250	.415	.470
14	.300	.465	.520
16	.350	.515	.570
20	.450	.615	.670
30	.700	.865	.920

- NOTES
- MATERIAL: BODY: LCP, UL94V-0
LATCH: PPA, UL94V-0
CONTACTS: COPPER ALLOY.
 - PLATING: 50-150µ" NICKEL UNDERPLATE
30 = 30µ" GOLD MIN. ON WIPING AREA WITH 200µ" MATTE TIN ON SOLDER TAIL
00 = GOLD FLASH ON WIPING AREA WITH 100-140µ" MATTE TIN ON SOLDER TAIL.
 - MATING COMPATIBILITY: 3M 1.27mm (0.050"), 451 SERIES RIBBON CABLE SOCKET. TECH SHEET 2436
 - REGULATORY INFORMATION: ROHS COMPLIANT. SEE THE REGULATORY INFORMATION APPENDIX (RIA) IN THE "ROHS COMPLIANCE" SECTION OF WWW.3MCONNECTORS.COM FOR COMPLIANCE INFORMATION (RIA E1 & C1 APPLY)
 - IN THE EVENT OF CONFLICT BETWEEN THIS DATA AND THAT CONTAINED IN THE PRODUCT SPECIFICATION, THE PRODUCT SPECIFICATION TAKES PRECEDENT.
 - REFERENCE PRODUCT SPEC: 3M DOC ID# 78-5102-0091-4
 - OTHER PIN COUNTS AVAILABLE UPON REQUEST. CONTACT 3M.
 - UNLESS OTHERWISE NOTED, REFERENCES TO INDUSTRY SPECIFICATIONS ARE INTENDED TO INDICATE SUBSTANTIAL COMPLIANCE TO THE MATERIAL ELEMENTS OF THE SPECIFICATION. SUCH REFERENCES SHOULD NOT BE CONSTRUED AS A GUARANTEE OF COMPLIANCE TO ALL REQUIREMENTS IN A GIVEN SPECIFICATION.
 - PACKAGING: VERTICAL THRU: TRAY
RIGHT ANGLE THRU: TRAY
VERTICAL SMT: TAPE AND REEL.

THRU BOARD, VERTICAL WITH LOW PROFILE LATCH/EJECT OPTION



THRU BOARD, VERTICAL

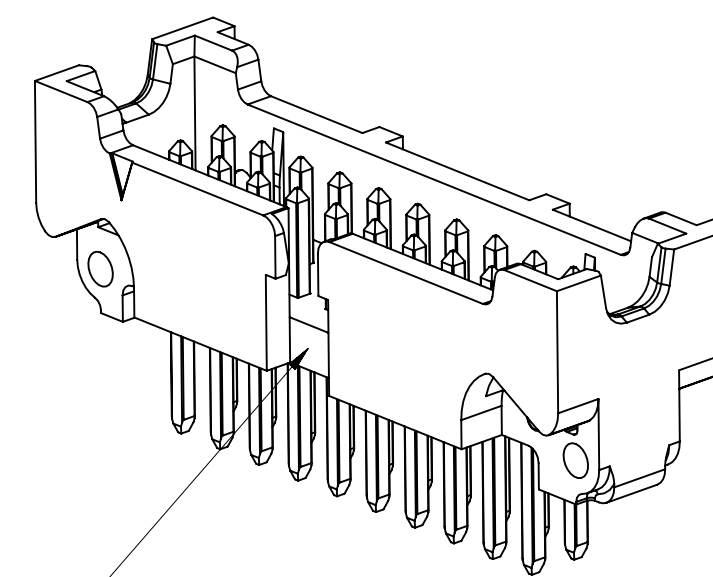

POLARIZATION AND FRICTION LATCHING POSITIONS 8-30 ONLY

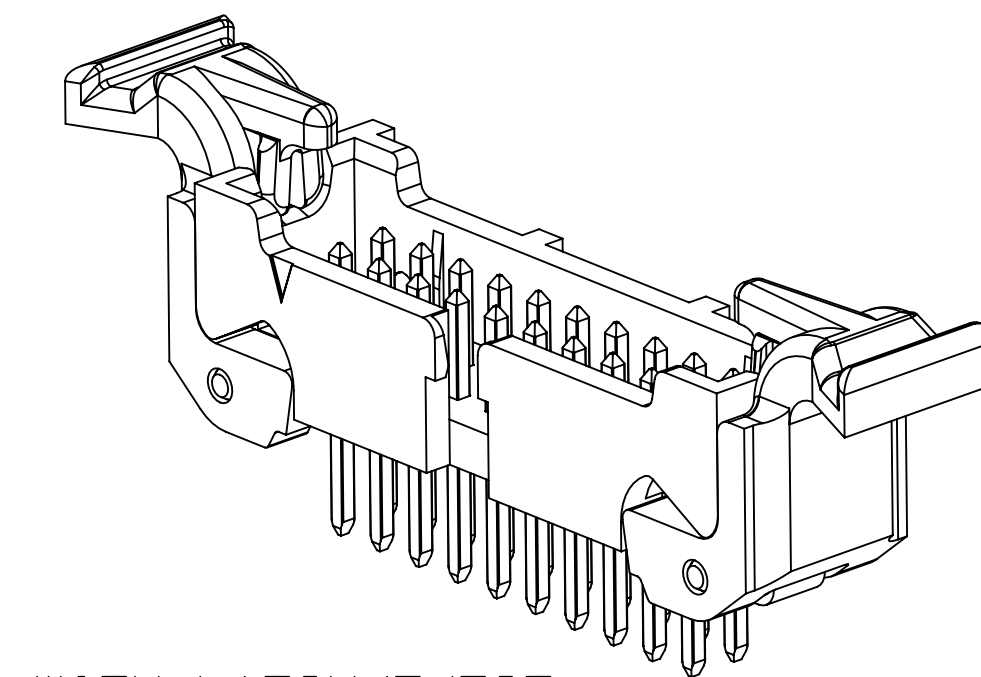

WITH LATCH/EJECT

PERFORMANCE:

CURRENT RATING: 1.0 A, ALL LINES ENERGIZED, 30°C TEMP RISE PER EIA 364-70
1.5 A, 6 LINES ENERGIZED, 30°C TEMP RISE PER EIA 364-70
2.5 A, 1 LINE ENERGIZED, 30°C TEMP RISE PER EIA 364-70

UL & CUL VOLTAGE RATING: 125V_{ac}
INSULATION RESISTANCE: > 1 x 10⁹ Ohms AT 500 VDC
WITHSTANDING VOLTAGE: 1250VACrms AT SEA LEVEL
OPERATING TEMPERATURE: -65°C to +125°C
UL & CUL OPERATING TEMPERATURE: +125°C
PROCESSING TEMPERATURE: 260°C
LEAD-FREE SOLDERABLE: YES
MOISTURE SENSITIVITY LEVEL: MSL1 PER J-STD-020

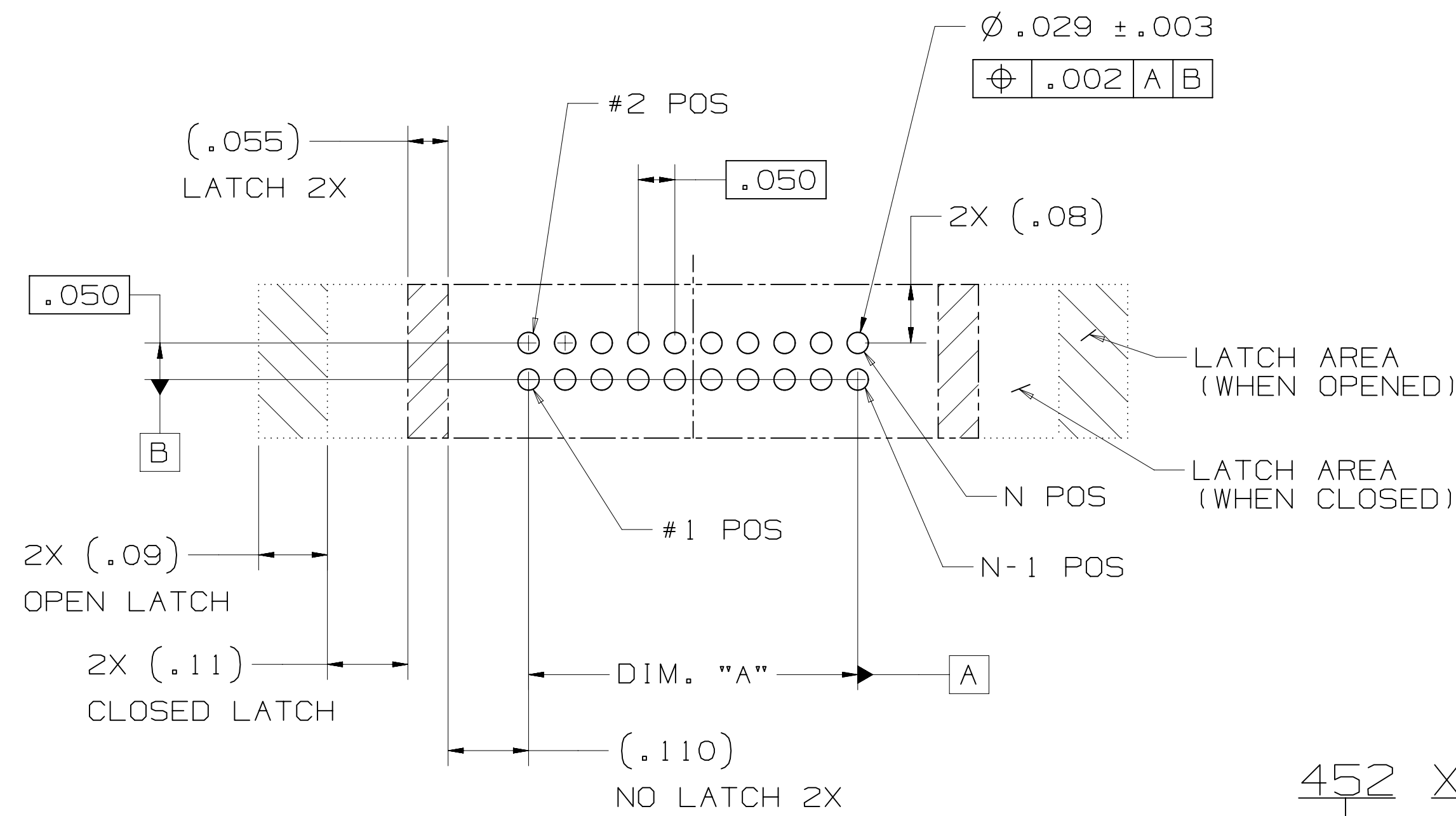

RECOMMENDED BOARD LAYOUT

452 XX - X X 0 2 XX
SERIES
POSITION COUNT
04 - 30
SEE TABLE 1

PLATING
00 = AU FLASH
30 = 30µ" GOLD

CONTACT TAIL
2 = STANDARD (.094")

PART CONFIG. AND PACKAGING
6 = VERTICAL THRU HOLE, TRAY PACKAGING
5 = RIGHT ANGLE THRU HOLE, TRAY PACKAGING
2 = VERTICAL SMT, TAPE AND REEL WITH VAC CAP

LATCH/EJECT
0 = NO LATCHES
2 = WITH LOW PROFILE LATCHES

3M ELECTRONIC MATERIALS SOLUTIONS DIVISION
INTERCONNECT SOLUTIONS
<http://www.3mconnectors.com>

3M IS A TRADEMARK OF 3M COMPANY.
FOR TECHNICAL, SALES OR ORDERING
INFORMATION CALL 800-225-5373

UL FILE NO: E68080

78-5100-2436-3
78-5100-2396-9

REV	ECO	ISSUE DATE AND DESCRIPTION	DRFT	CHKD
F	56988	SEP 24, 2014 REVISE PERFORMANCE CHART	JNC	SN
E	54514	JUN 19, 2014 ADD UL LOGO, ADD 56MM T&R	SJS	SAN
D	51884	JAN 08, 2014 ADD DESIGN REF, UPDATE TITLE	SJS	SAN
C	50290	OCT 08, 2013 REVISE NOTE 1, 9 & OPERATING TEMP.	JNC	SN
B	48635	JUL 12, 2013 MATCH TEXT FONTS & ADD NOTE 9	JNC	SN
A	46797	MAR 25, 2013 PRODUCTION RELEASE	JNC	SAN

DESIGN REFERENCE: INTERCONNECT SOLUTIONS
SCALE: 6-1
TOLERANCES EXCEPT AS NOTED

INCHES: .00 ±.01, .00 ±.02, .000 ±.010, .0000 ±.0050
MILLIMETERS: 0, .0 ±.1, .00 ±.01, .00 ±.01

3M BOARDMOUNT HEADER, .05 X .05 PITCH, L/E, 452 SERIES

CAGE NUMBER: D78-5100-2437-1
REV. NUMBER: F

Imaged: F.1 9/24/2014 9:06 AM UTC-05:00

3M™ SHROUDED BOARDMOUNT HEADER, 1.27mm (0.050") PITCH
LATCH AND EJECT, 452 SERIES

TABLE 1: RIGHT ANGLE THRU

No. Positions	Dim "A"	Dim "B"	Dim "C"
4	.050	.215	.270
6	.100	.265	.320
8	.150	.315	.370
10	.200	.365	.420
12	.250	.415	.470
14	.300	.465	.520
16	.350	.515	.570
20	.450	.615	.670
30	.700	.865	.920

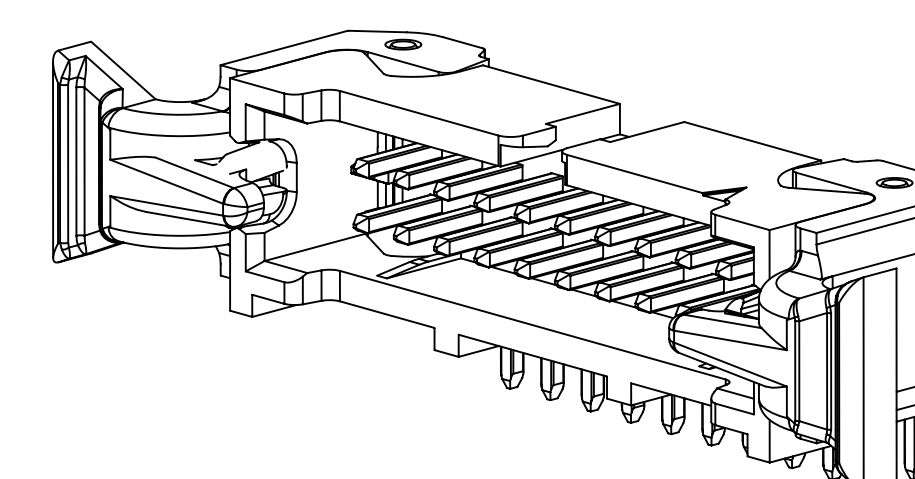
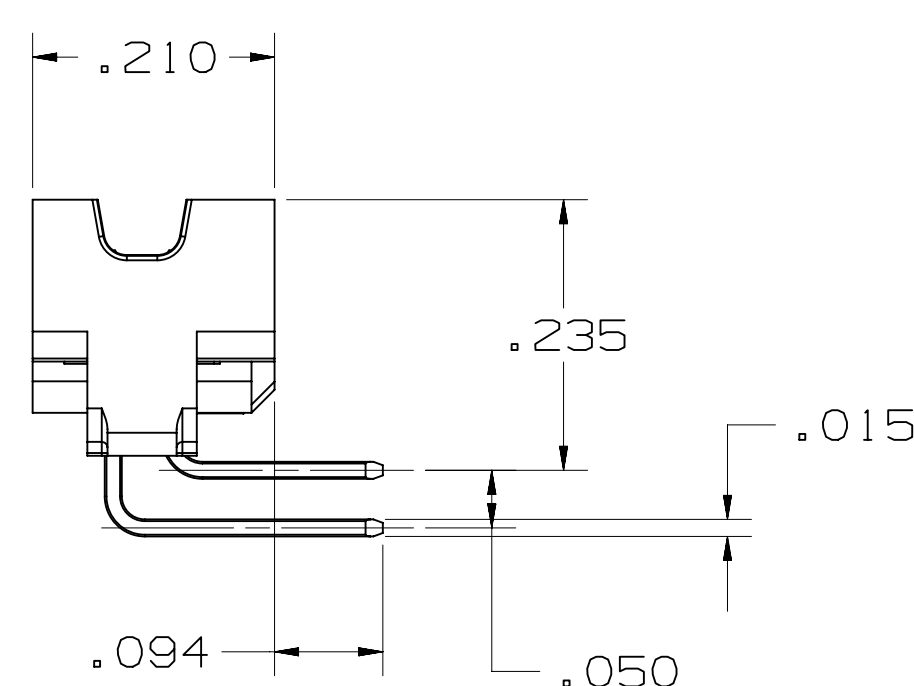
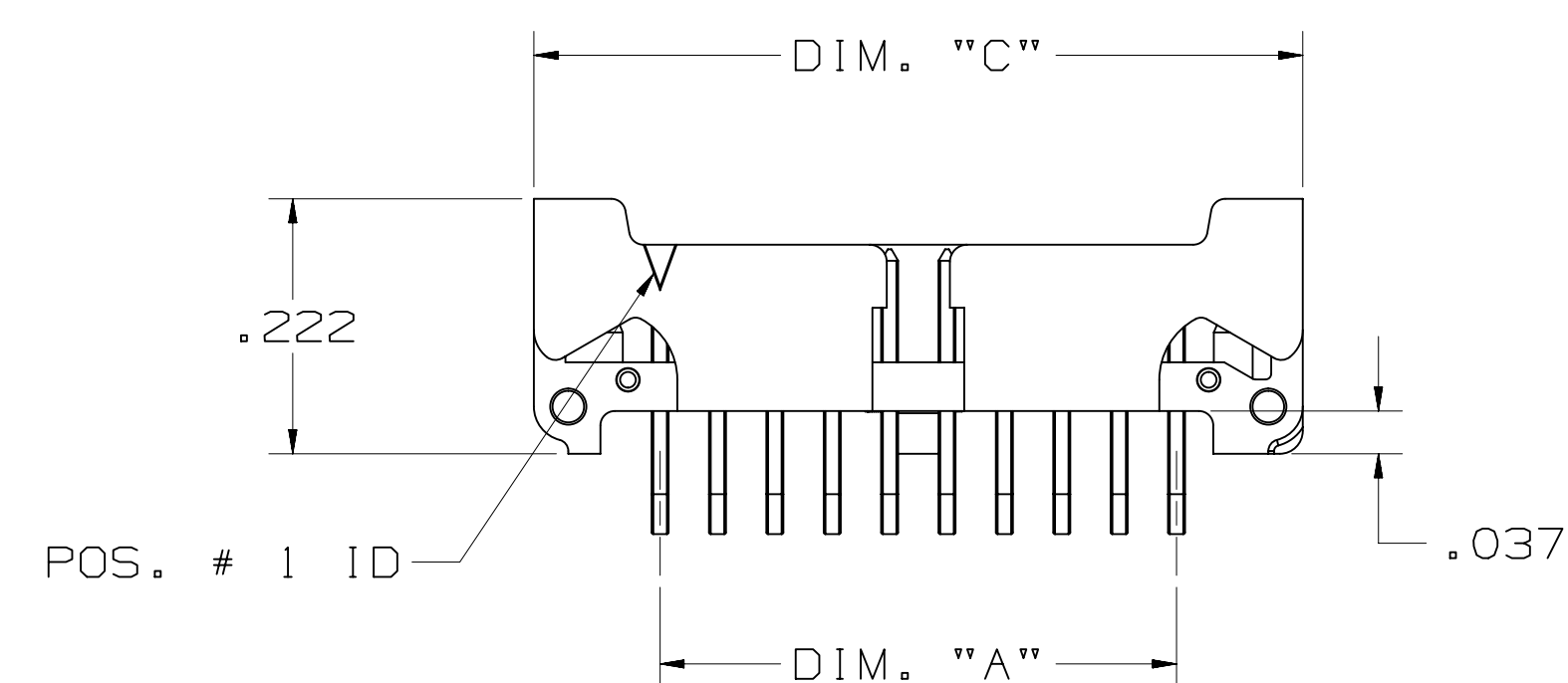
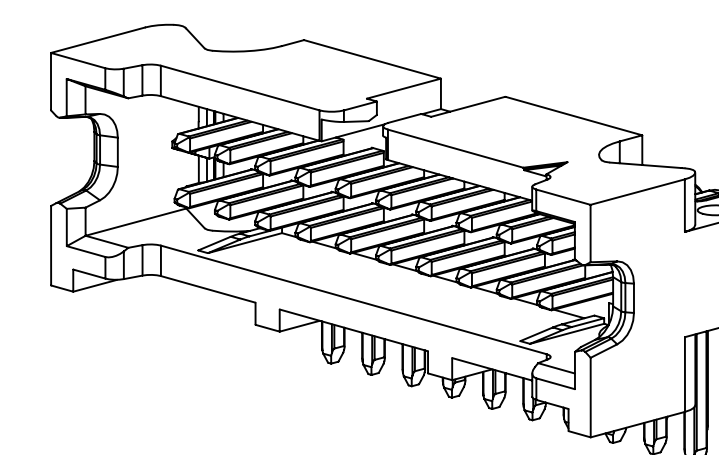
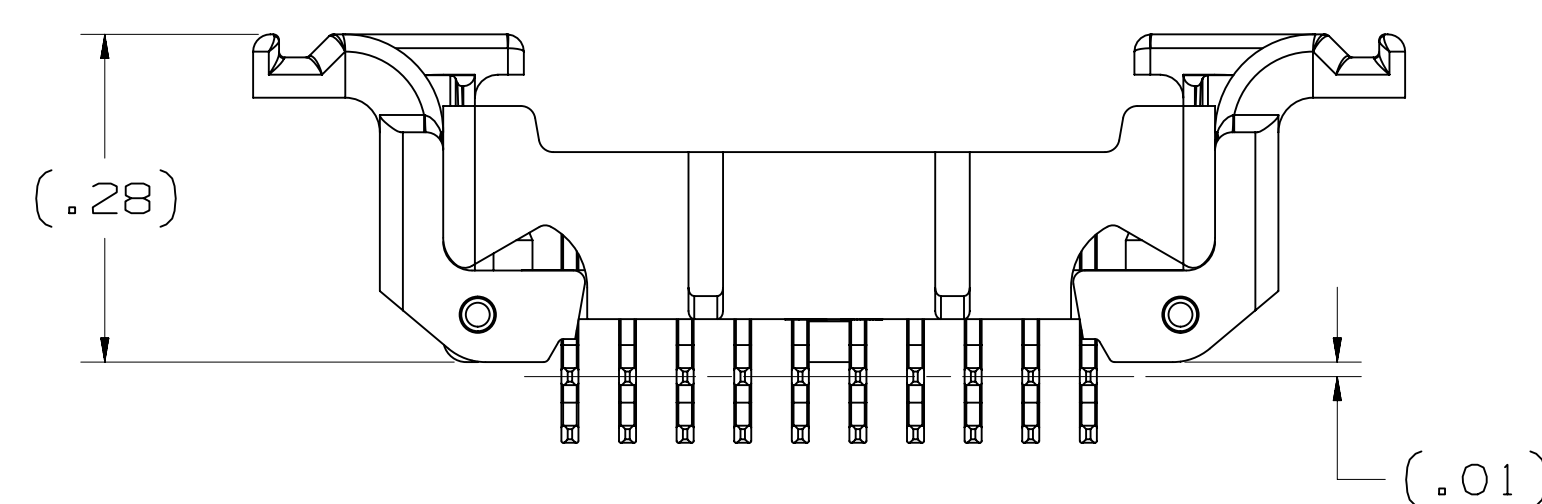
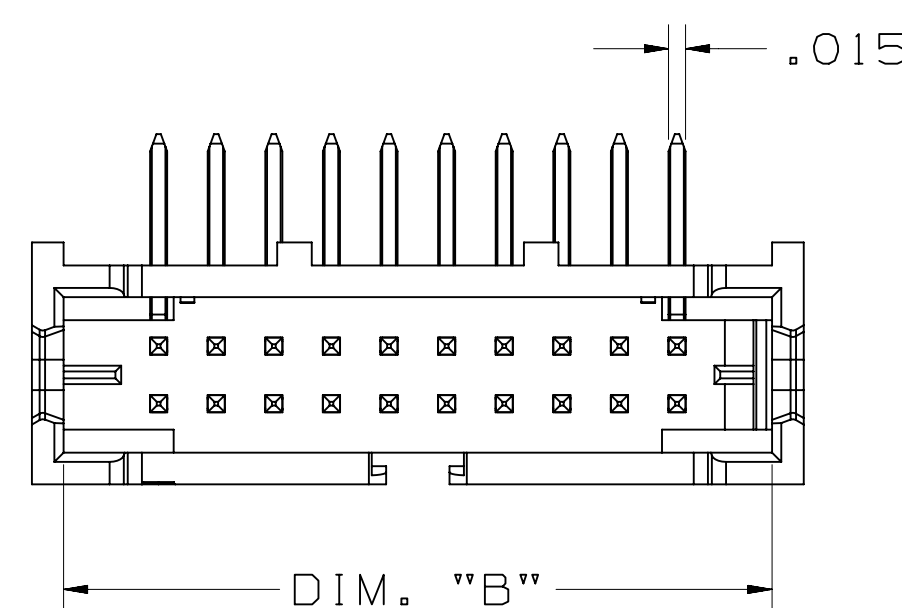

THRU BOARD, RIGHT ANGLE

WITH LATCH/EJECT

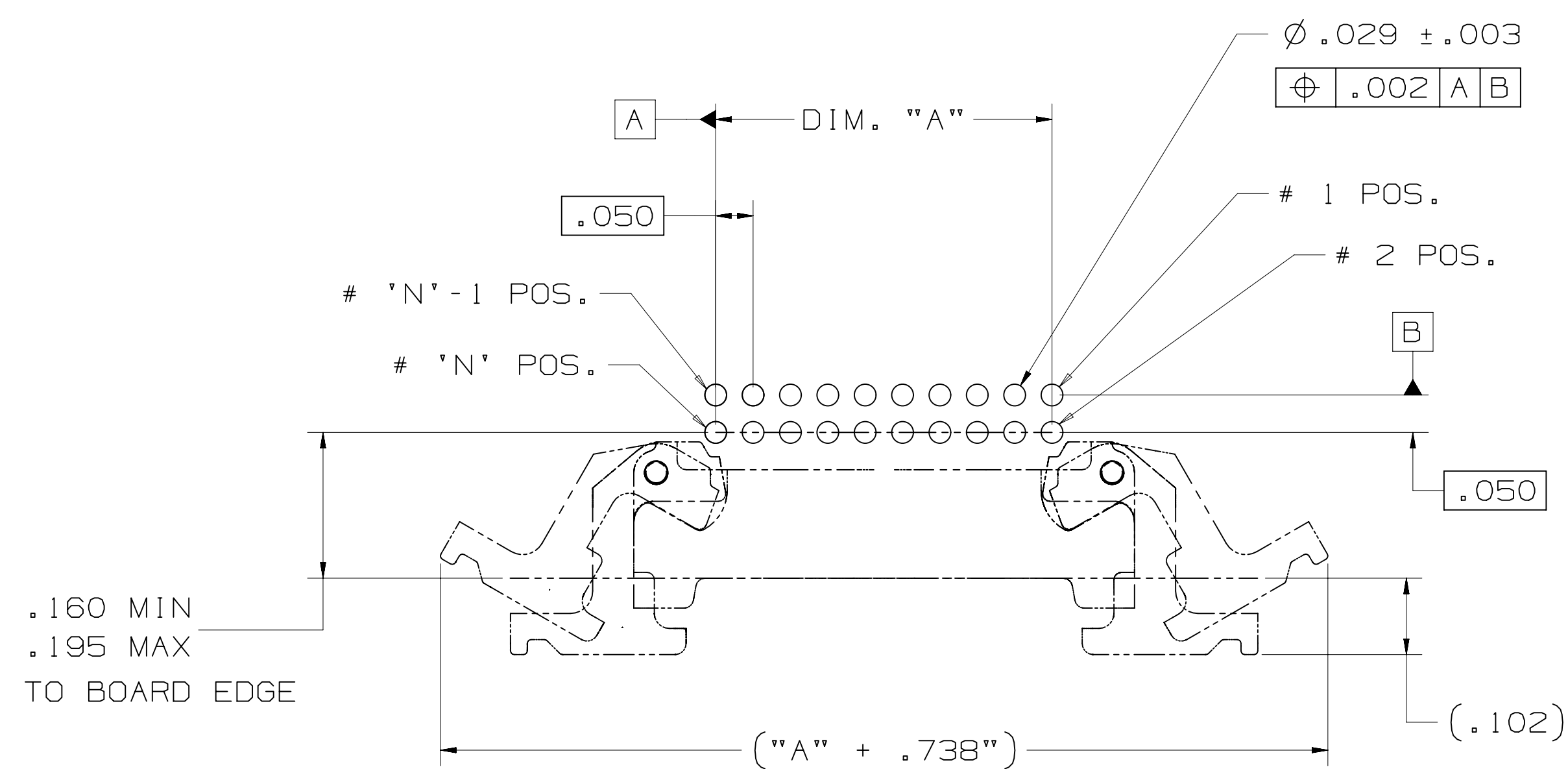

RECOMMENDED BOARD LAYOUT

78-5100-2436-3
78-5100-2396-9

DESIGN REFERENCE NEXT ASSEMBLY

REV	ECO	ISSUE DATE AND DESCRIPTION	DRFT	CHKD
ARM		NOV 29, 2012 PRC		NOV 29, 2012
SAN		NOV 29, 2012 SAN		NOV 29, 2012

DIVISION CODE

Interconnect Solutions ISD

DO NOT SCALE DRAWING

SCALE 6/1

TOLERANCES EXCEPT AS NOTED

INCHES .0 ± .1

.00 ± .02

.000 ± .010

.0000 ± .0050

MILLIMETERS 0 ±

.0 ±

.00 ±

.00 ±

MARKED ONLY ANGLES ±

REV	ECO	ISSUE DATE AND DESCRIPTION	DRFT	CHKD
F	56988	SEP 24, 2014 REVISE PERFORMANCE CHART	JNC	SN
E	54514	JUN 19, 2014 ADD UL LOGO, ADD 56MM T&R	SJS	SAN
D	51884	JAN 08, 2014 ADD DESIGN REF, UPDATE TITLE	SJS	SAN
C	50290	OCT 08, 2013 REVISE NOTE 1, 9 & OPERATING TEMP.	JNC	SN
B	48635	JUL 12, 2013 MATCH TEXT FONTS & ADD NOTE 9	JNC	SN
A	46797	MAR 25, 2013 PRODUCTION RELEASE	JNC	SAN

© 3M COPYRIGHT 2014

This document and the information it contains are 3M property and may not be reproduced or further distributed without 3M permission, or used or disclosed other than for 3M authorized purposes. All rights reserved.

3M Center St. Paul, MN 55144

TITLE BOARDMOUNT HEADER, .05 X .05 PITCH, L/E, 452 SERIES

CAGE NUMBER D78-5100-2437-1

REV. F

MODEL

DET. [] SHT 2 OF 4

IS1S [] YES [X] NO

ANGLES ±

MARKED ONLY

INTERPRET PER ASME Y14.5 - 2009

THIRD ANGLE PROJECTION

MAX SURFACE ROUGHNESS

78-5100-2437-1 F REVISION DRAWING NUMBER

Imaged: F.1 9/24/2014 9:06 AM UTC-05:00

3M™ SHROUDED BOARDMOUNT HEADER, 1.27mm (0.050") PITCH
LATCH AND EJECT, 452 SERIES

TABLE 1: VERTICAL SMT

No. Positions	Dim "A"	Dim "B"	Dim "C"
4	.050	.215	.270
6	.100	.265	.320
8	.150	.315	.370
10	.200	.365	.420
12	.250	.415	.470
14	.300	.465	.520
16	.350	.515	.570
20	.450	.615	.670
30	.700	.865	.920

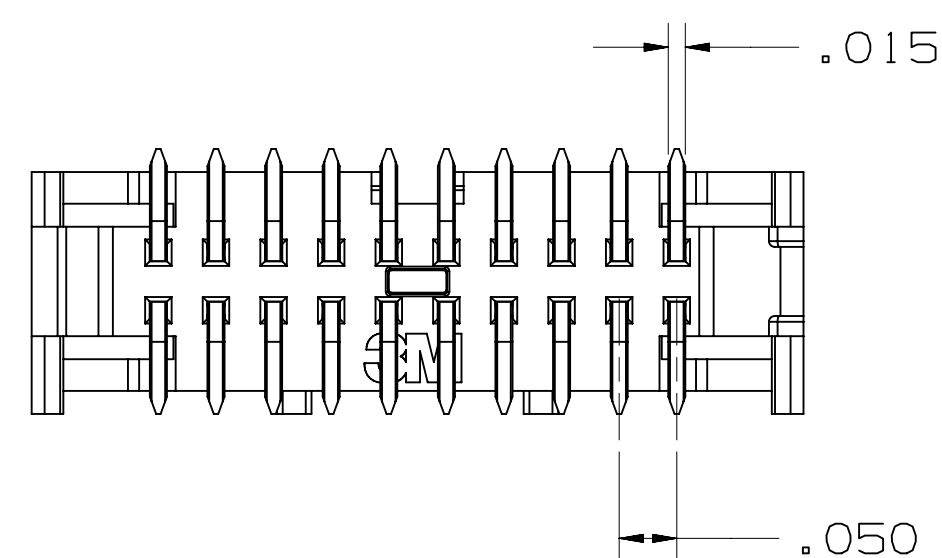
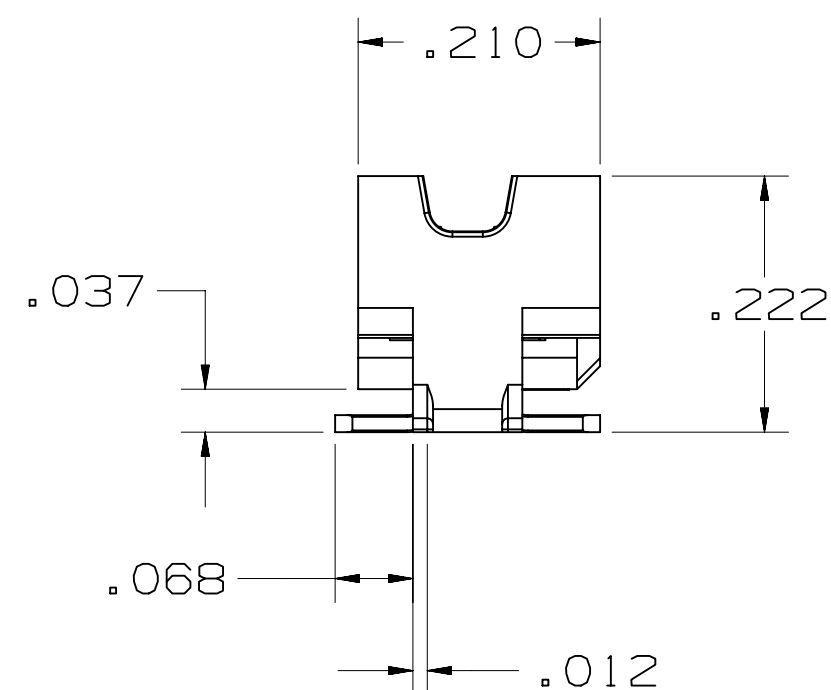
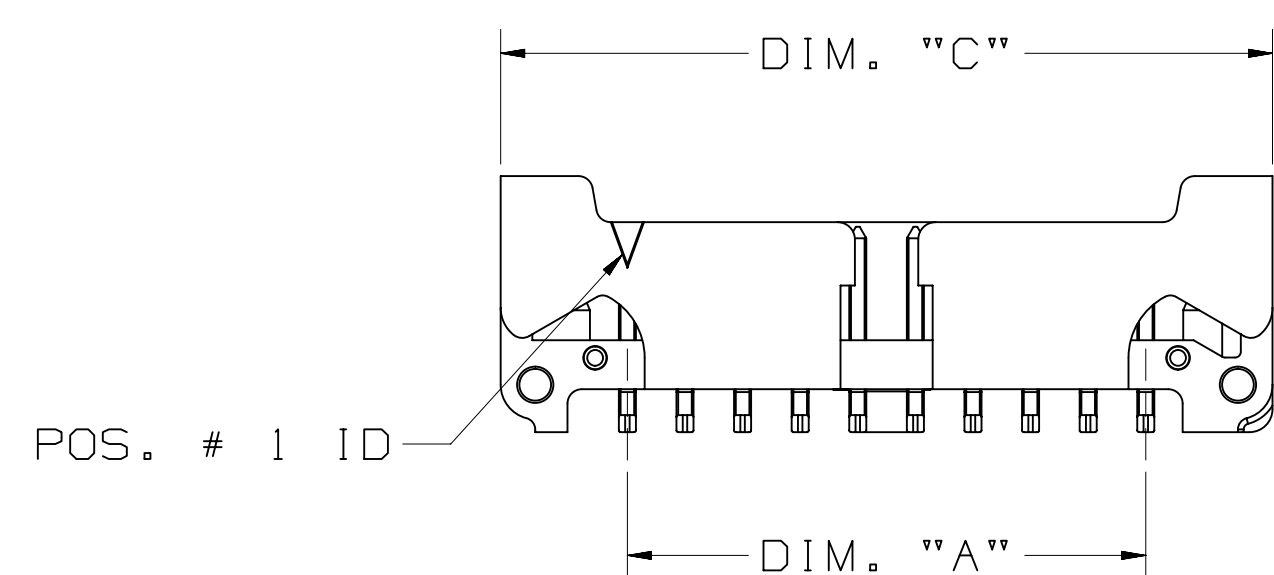
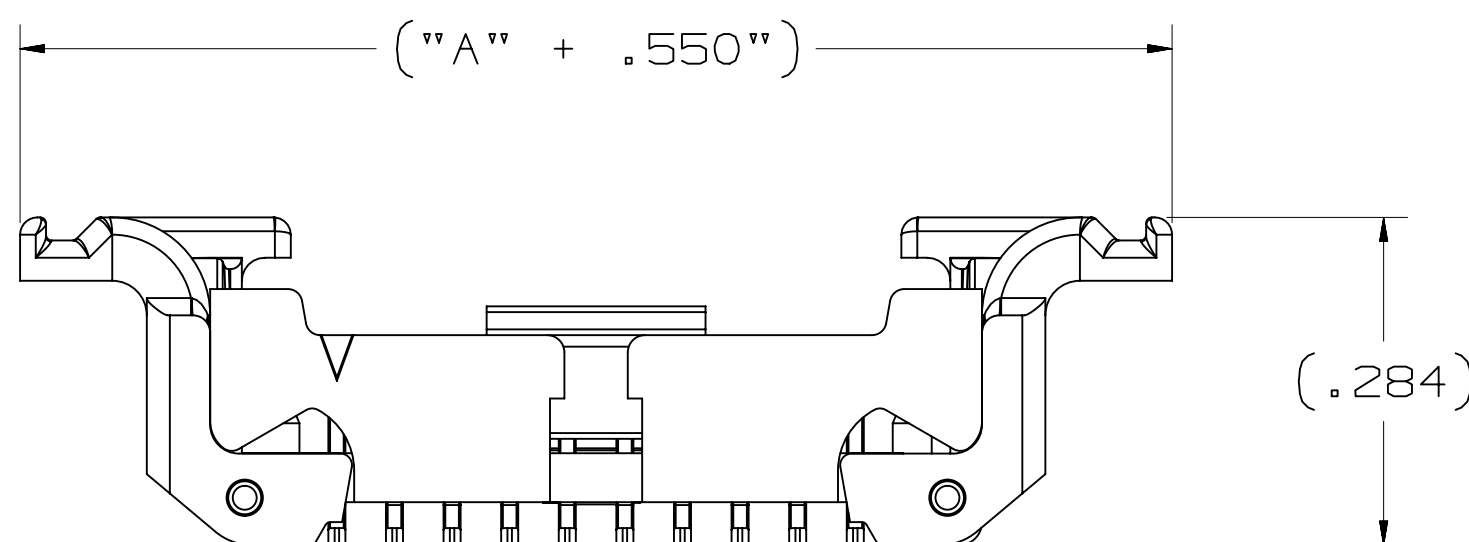
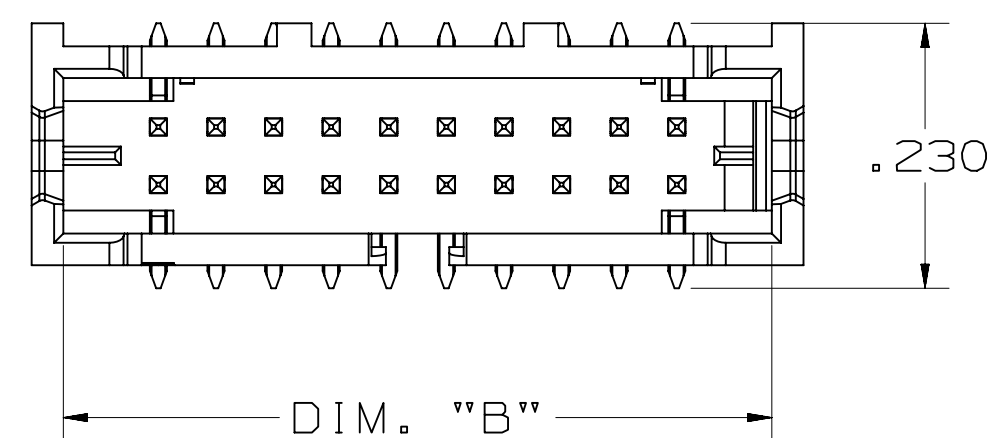

SURFACE MOUNT, VERTICAL

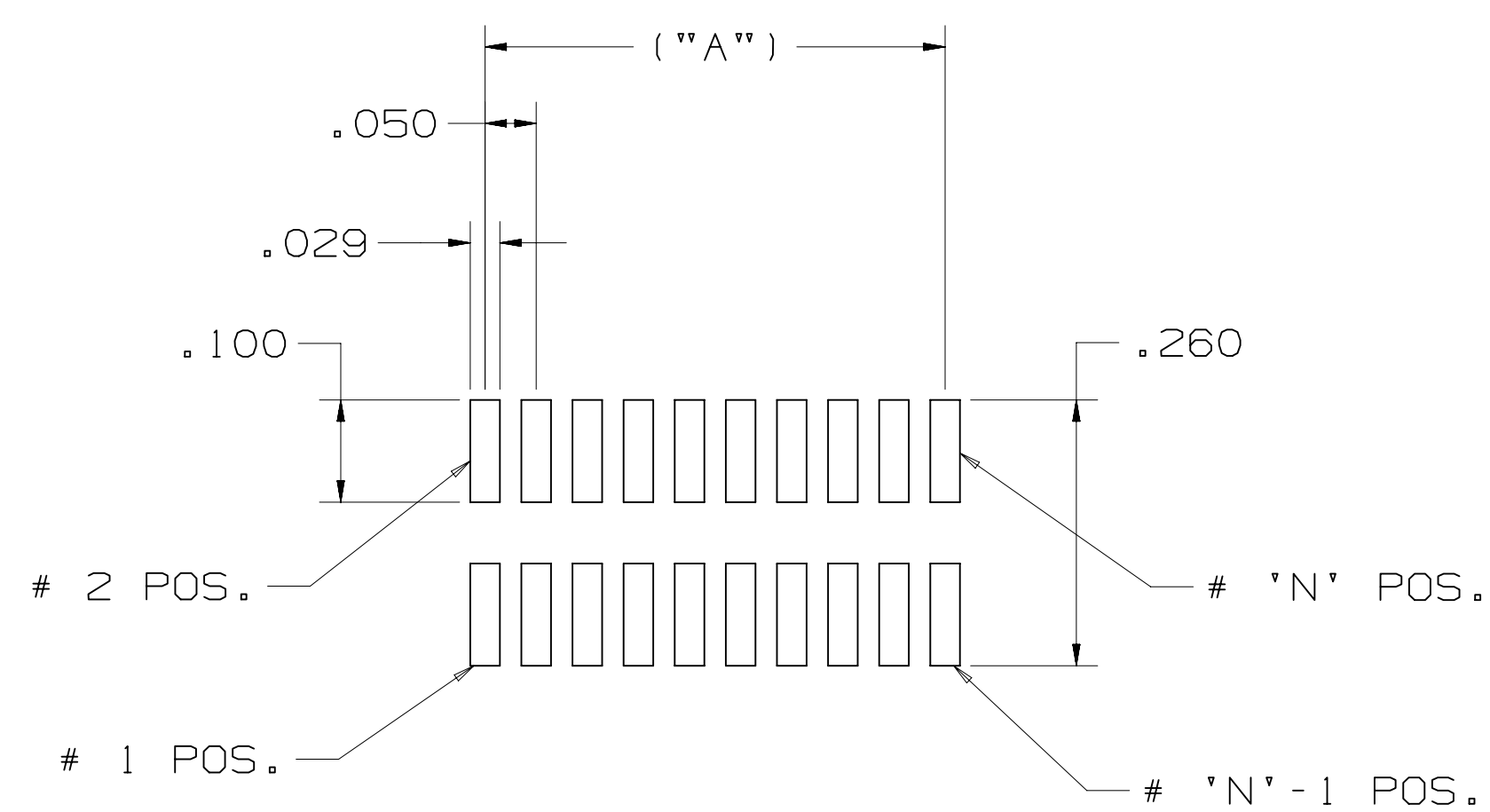

RECOMMENDED BOARD LAYOUT

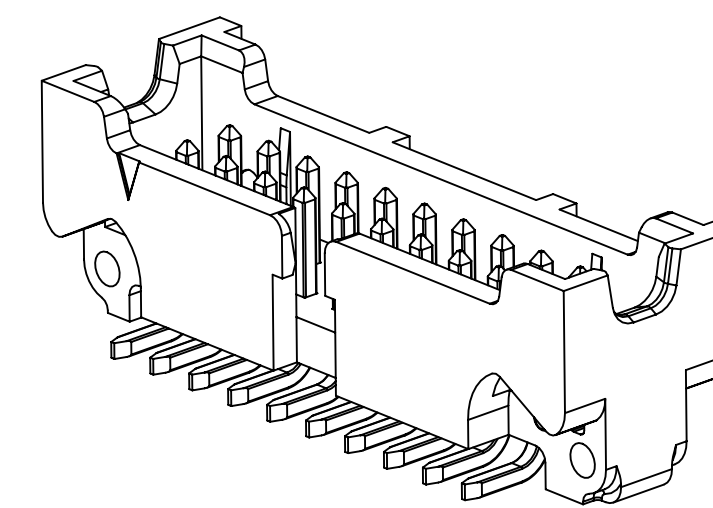

SHROUDED SMT HEADER

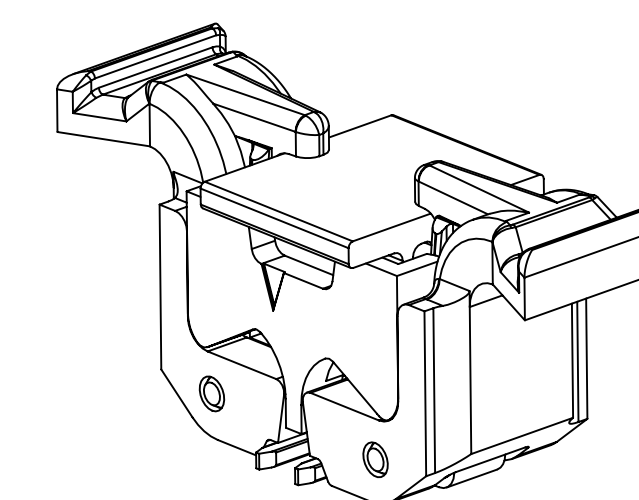
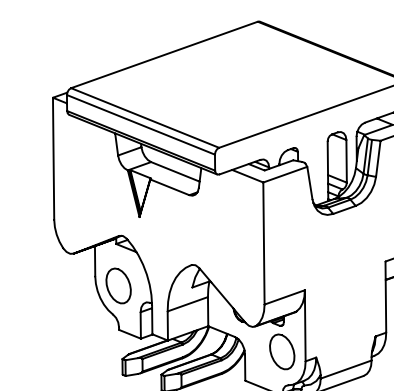

VACUUM CAP SEATED ON TOP
EDGES OF END WALLS ON
POSITIONS 4 AND 6

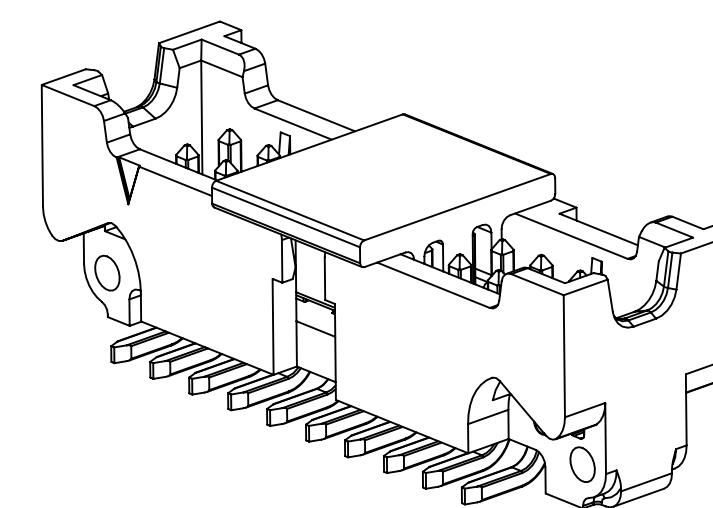

WITH VACUUM CAP

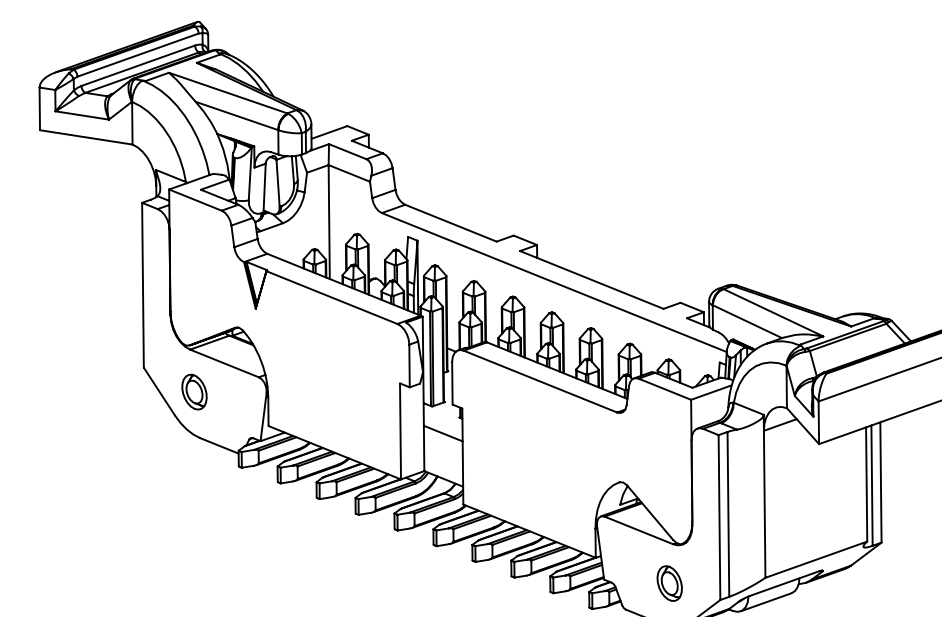

WITH LATCH/EJECT

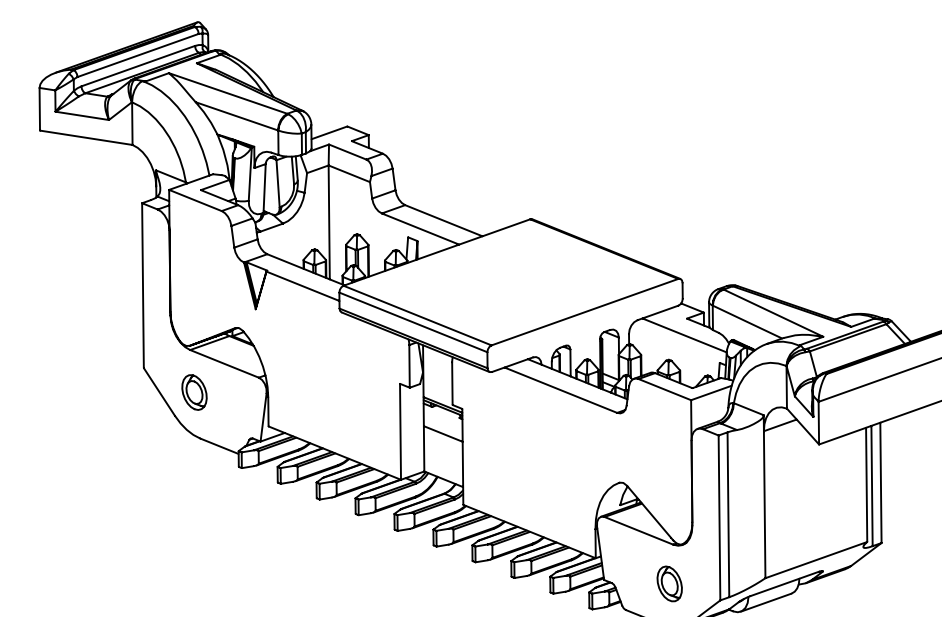

WITH LATCH/EJECT
AND VACUUM CAP
VACUUM CAP IS FULLY SEATED
ON POSITIONS 8 THRU 30

REV	ECO	ISSUE DATE AND DESCRIPTION	DRFT	CHKD
F	56988	SEP 24, 2014 REVISE PERFORMANCE CHART	JNC	SN
E	54514	JUN 19, 2014 ADD UL LOGO, ADD 56MM T&R	SJS	SAN
D	51884	JAN 08, 2014 ADD DESIGN REF, UPDATE TITLE	SJS	SAN
C	50290	OCT 08, 2013 REVISE NOTE 1, 9 & OPERATING TEMP.	JNC	SN
B	48635	JUL 12, 2013 MATCH TEXT FONTS & ADD NOTE 9	JNC	SN
A	46797	MAR 25, 2013 PRODUCTION RELEASE	JNC	SAN

78-5100-2436-3
78-5100-2396-9

DESIGN REFERENCE NEXT ASSEMBLY

DRFT	DATE	DRFT	DATE
ARM	NOV 29, 2012	PRC	NOV 29, 2012
SAN	NOV 29, 2012	SAN	NOV 29, 2012

DIVISION: Interconnect Solutions

SCALE: 6/1

THIRD ANGLE PROJECTION

INTERPRET PER ASME Y14.5 - 2009

MAX SURFACE ROUGHNESS

MARKED ONLY

© 3M COPYRIGHT 2014
This document and the information it contains are 3M property and may not be reproduced or further distributed without 3M permission, or used or disclosed other than for 3M authorized purposes. All rights reserved.

TITLE: BOARDMOUNT HEADER, .05 X .05 PITCH, L/E, 452 SERIES

CAGE NUMBER: D78-5100-2437-1

REV. F

78-5100-2437-1 F REVISION
IMAGED: F.1 9/24/2014 9:06 AM UTC-05:00

3M™ SHROUDED BOARDMOUNT HEADER, 1.27mm (0.050") PITCH
LATCH AND EJECT, 452 SERIES

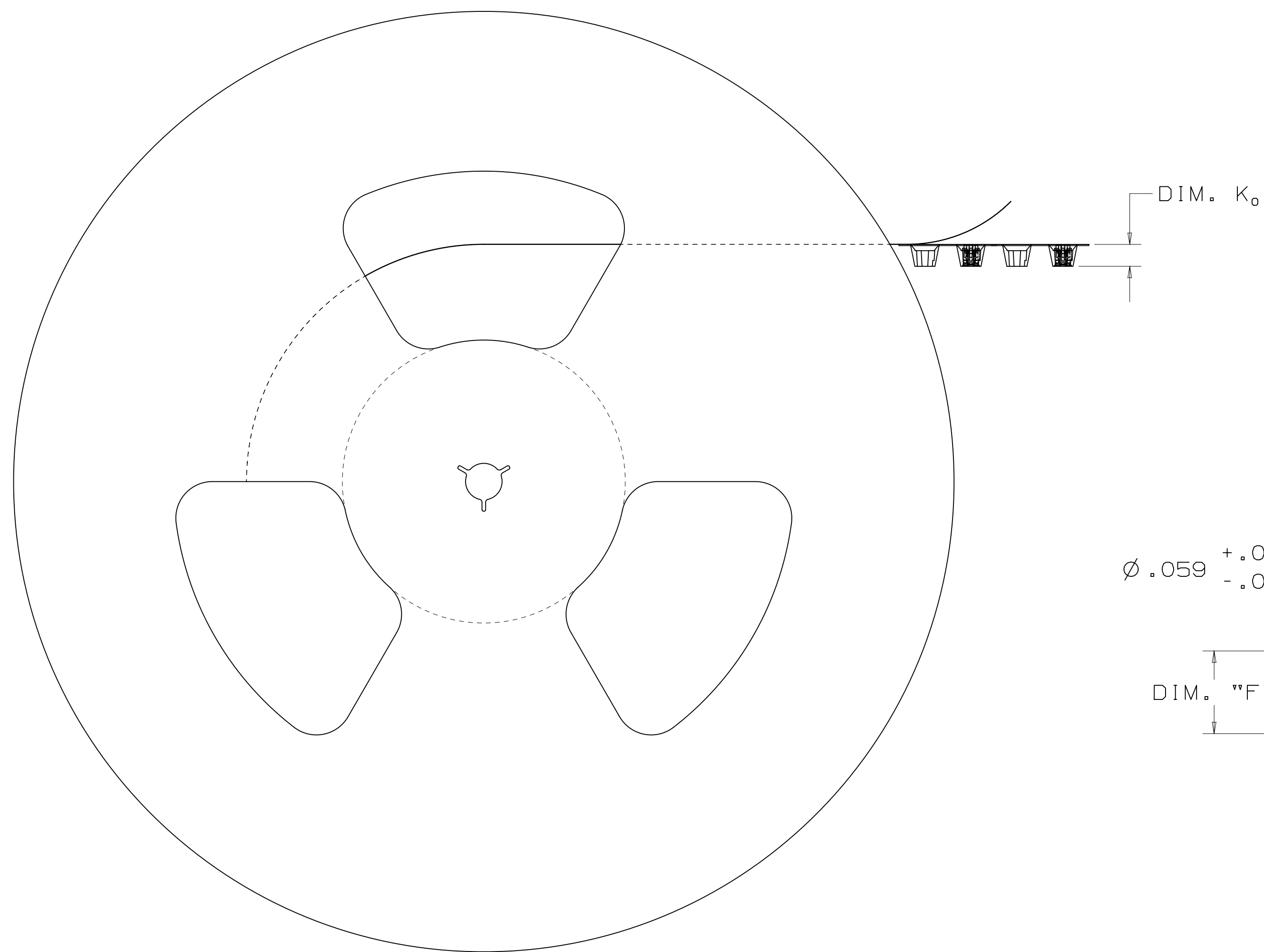
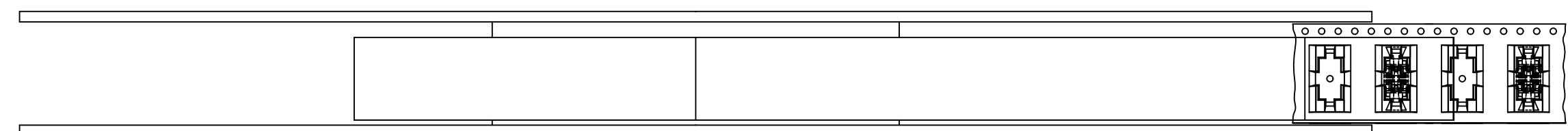
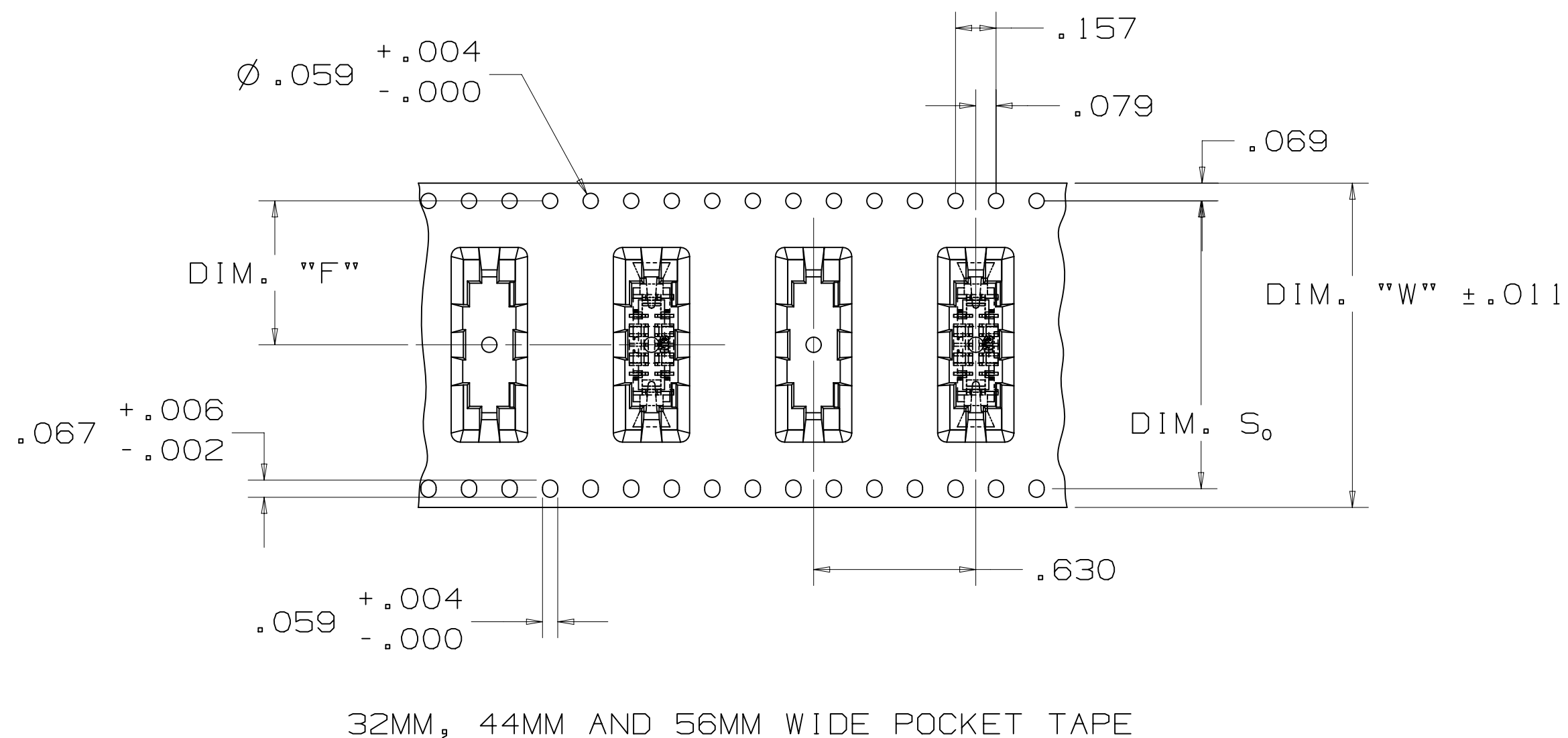
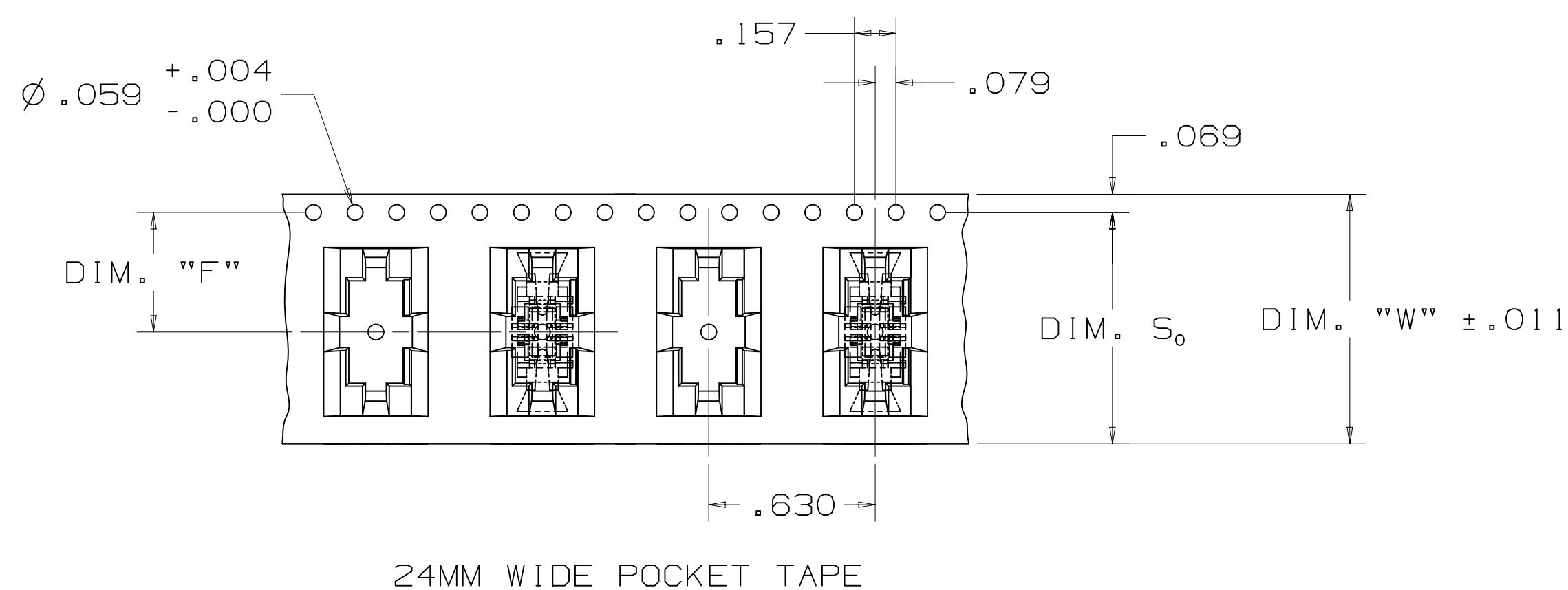

TABLE 2
TAPE AND REEL PACKAGING FOR SURFACEMOUNT HEADERS

POS	LATCHES	DIM. "F"	DIM. K ₀	DIM. S ₀	DIM. "W"
4	NO	.453	.263	.876	.945 [24MM]
4	YES	.453	.300	.876	1.260 [32MM]
6	NO	.453	.238	.876	.945 [24MM]
6	YES	.559	.300	1.118	1.260 [32MM]
8	NO	.453	.238	.876	.945 [24MM]
8	YES	.559	.300	1.118	1.732 [44MM]
10	NO	.453	.238	.876	.945 [24MM]
10	YES	.559	.300	1.118	1.732 [44MM]
12	NO	.453	.238	.876	.945 [24MM]
12	YES	.559	.300	1.118	1.732 [44MM]
14	NO	.453	.238	.876	.945 [24MM]
14	YES	.795	.300	1.591	1.732 [44MM]
16	NO	.453	.238	.876	.945 [24MM]
16	YES	.795	.300	1.591	1.732 [44MM]
20	NO	.559	.238	1.118	1.260 [32MM]
20	YES	.795	.300	1.591	1.732 [44MM]
30	NO	.795	.238	1.591	1.732 [44MM]
30	YES	.795	.300	1.591	2.205 [56MM]

NOTE:
LATCH EJECT HEADERS ARE PACKAGED WITH THE LATCHES
IN AN OPEN POSITION.



78-5100-2436-3
78-5100-2396-9

DESIGN REFERENCE	NEXT ASSEMBLY
ISSUE CODES	ISSUE DATE AND DESCRIPTION
DIVISION	DIVISION CODE
Interconnect Solutions	ISD
DO NOT SCALE DRAWING	TOLERANCES EXCEPT AS NOTED
THIRD ANGLE PROJECTION	INCHES
INTERPRET PER ASME Y14.5 - 2009	MILLIMETERS
MAX SURFACE ROUGHNESS	ANGLES
MARKED ONLY	

REV	ECO	ISSUE DATE AND DESCRIPTION	DRFT	CHKD
F	56988	SEP 24, 2014 REVISE PERFORMANCE CHART	JNC	SN
E	54514	JUN 19, 2014 ADD UL LOGO, ADD 56MM T&R	SJS	SAN
D	51884	JAN 08, 2014 ADD DESIGN REF, UPDATE TITLE	SJS	SAN
C	50290	OCT 08, 2013 REVISE NOTE 1, 9 & OPERATING TEMP.	JNC	SN
B	48635	JUL 12, 2013 MATCH TEXT FONTS & ADD NOTE 9	JNC	SN
A	46797	MAR 25, 2013 PRODUCTION RELEASE	JNC	SAN

© 3M COPYR[IGHT] 2014
3M Center
St. Paul, MN 55144

TITLE
BOARDMOUNT HEADER,
.05 X .05 PITCH, L/E,
452 SERIES

CAGE NUMBER
D 78-5100-2437-1

REV. F

MODEL
SHT 4 OF 4

78-5100-2437-1
DRAWING NUMBER
F
REVISION
AM UTC-05:00
9:06
F.1 9/24/2014



Компания «ЭлектроПласт» предлагает заключение долгосрочных отношений при поставках импортных электронных компонентов на взаимовыгодных условиях!

Наши преимущества:

- Оперативные поставки широкого спектра электронных компонентов отечественного и импортного производства напрямую от производителей и с крупнейших мировых складов;
- Поставка более 17-ти миллионов наименований электронных компонентов;
- Поставка сложных, дефицитных, либо снятых с производства позиций;
- Оперативные сроки поставки под заказ (от 5 рабочих дней);
- Экспресс доставка в любую точку России;
- Техническая поддержка проекта, помощь в подборе аналогов, поставка прототипов;
- Система менеджмента качества сертифицирована по Международному стандарту ISO 9001;
- Лицензия ФСБ на осуществление работ с использованием сведений, составляющих государственную тайну;
- Поставка специализированных компонентов (Xilinx, Altera, Analog Devices, Intersil, Interpoint, Microsemi, Aeroflex, Peregrine, Syfer, Eurofarad, Texas Instrument, Miteq, Cobham, E2V, MA-COM, Hittite, Mini-Circuits, General Dynamics и др.);

Помимо этого, одним из направлений компании «ЭлектроПласт» является направление «Источники питания». Мы предлагаем Вам помощь Конструкторского отдела:

- Подбор оптимального решения, техническое обоснование при выборе компонента;
- Подбор аналогов;
- Консультации по применению компонента;
- Поставка образцов и прототипов;
- Техническая поддержка проекта;
- Защита от снятия компонента с производства.



Как с нами связаться

Телефон: 8 (812) 309 58 32 (многоканальный)

Факс: 8 (812) 320-02-42

Электронная почта: org@eplast1.ru

Адрес: 198099, г. Санкт-Петербург, ул. Калинина, дом 2, корпус 4, литера А.