

HSP45102

12-Bit Numerically Controlled Oscillator

FN2810
Rev 9.01
Jan 28, 2020

The HSP45102 is Numerically Controlled Oscillator (NCO12) with 32-bit frequency resolution and 12-bit output. With over 69dB of spurious free dynamic range and worst case frequency resolution of 0.009Hz, the NCO12 provides significant accuracy for frequency synthesis solutions at a competitive price.

The frequency to be generated is selected from two frequency control words. A single control pin selects which word is used to determine the output frequency. Switching from one frequency to another occurs in one clock cycle, with a 6 clock pipeline delay from the time that the new control word is loaded until the new frequency appears on the output.

Two pins, PO-1, are provided for phase modulation. They are encoded and added to the top two bits of the phase accumulator to offset the phase in 90° increments.

The 13-bit output of the Phase Offset Adder is mapped to the sine wave amplitude via the Sine ROM. The output data format is offset binary to simplify interfacing to D/A converters. Spurious frequency components in the output sinusoid are less than -69dBc.

The NCO12 has applications as a Direct Digital Synthesizer and modulator in low cost digital radios, satellite terminals, and function generators.

Features

- 33MHz, 40MHz Versions
- 32-Bit Frequency Control
- BFSK, QPSK Modulation
- Serial Frequency Load
- 12-Bit Sine Output
- Offset Binary Output Format
- 0.009Hz Tuning Resolution at 40MHz
- Spurious Frequency Components <-69dBc
- Fully Static CMOS
- Low Cost
- Pb-Free Plus Anneal Available (RoHS Compliant)

Applications

- Direct Digital Synthesis
- Modulation
- PSK Communications
- Related Products
 - HI5731 12-Bit, 100MHz D/A Converter

Ordering Information

PART NUMBER	PART MARKING	TEMP. RANGE (°C)	PACKAGE	PKG. DWG. #
HSP45102SC-33 (No longer available, recommended replacement: HSP45102SC-33Z)	HSP45102SC-33	0 to +70	28 Ld SOIC (300 mil)	M28.3
HSP45102SC-33Z (Note)	HSP45102SC-33Z	0 to +70	28 Ld SOIC (300 mil) (Pb-free)	M28.3
HSP45102SC-40	HSP45102SC -40	0 to +70	28 Ld SOIC (300 mil)	M28.3
HSP45102SC-40Z (Note)	HSP45102SC-40Z	0 to +70	28 Ld SOIC (300 mil)(Pb-free)	M28.3
HSP45102SI-33Z (Note)	HSP45102SI-33Z	0 to +70	28 Ld SOIC (300 mil) (Pb-free)	M28.3

NOTE: Pb-free plus anneal products employ special Pb-free material sets; molding compounds/die attach materials and 100% matte tin plate termination finish, which are RoHS compliant and compatible with both SnPb and Pb-free soldering operations. Pb-free products are MSL classified at Pb-free peak reflow temperatures that meet or exceed the Pb-free requirements of IPC/JEDEC J STD-020.

Block Diagram

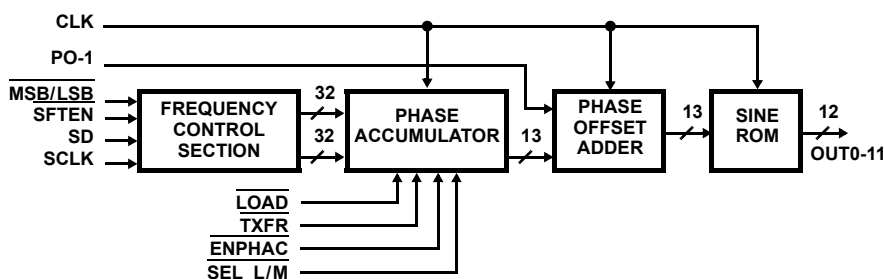

Pinout

HSP45102
(28 LEAD SOIC)
TOP VIEW

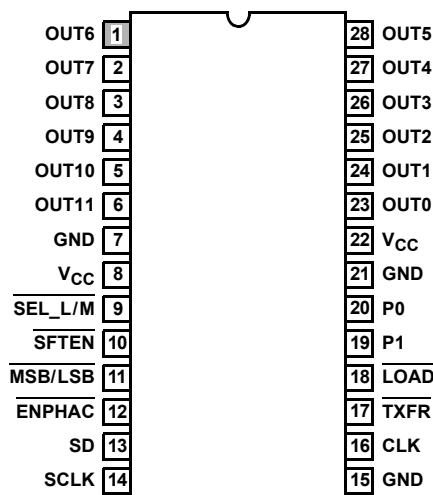

Pin Description

NAME	TYPE	DESCRIPTION
V _{CC}		+5V power supply pin.
GND		Ground
P0-1	I	Phase modulation inputs (become active after a pipeline delay of four clocks). A phase shift of 0°, 90°, 180°, or 270° can be selected as shown in Table 1.
CLK	I	NCO clock. (CMOS level)
SCLK	I	This pin clocks the frequency control shift register.
<u>SEL_L/M</u>	I	A high on this input selects the least significant 32 bits of the 64-bit frequency register as the input to the phase accumulator; a low selects the most significant 32 bits.
<u>SFTEN</u>	I	The active low input enables the shifting of the frequency register.
<u>MSB/LSB</u>	I	This input selects the shift direction of the frequency register. A low on this input shifts in the data LSB first; a high shifts in the data MSB first.
<u>ENPHAC</u>	I	This pin, when low, enables the clocking of the Phase Accumulator. This input has a pipeline delay of four clocks.
SD	I	Data on this pin is shifted into the frequency register by the rising edge of SCLK when <u>SFTEN</u> is low.
<u>TXFR</u>	I	This active low input is clocked onto the chip by CLK and becomes active after a pipeline delay of four clocks. When low, the frequency control word selected by <u>SEL_L/M</u> is transferred from the frequency register to the phase accumulator's input register.
<u>LOAD</u>	I	This input becomes active after a pipeline delay of five clocks. When low, the feedback in the phase accumulator is zeroed.
OUT0-11	O	Output data. OUT0 is LSB. Unsigned.

All inputs are TTL level, with the exception of CLK.

Overline designates active low signals.

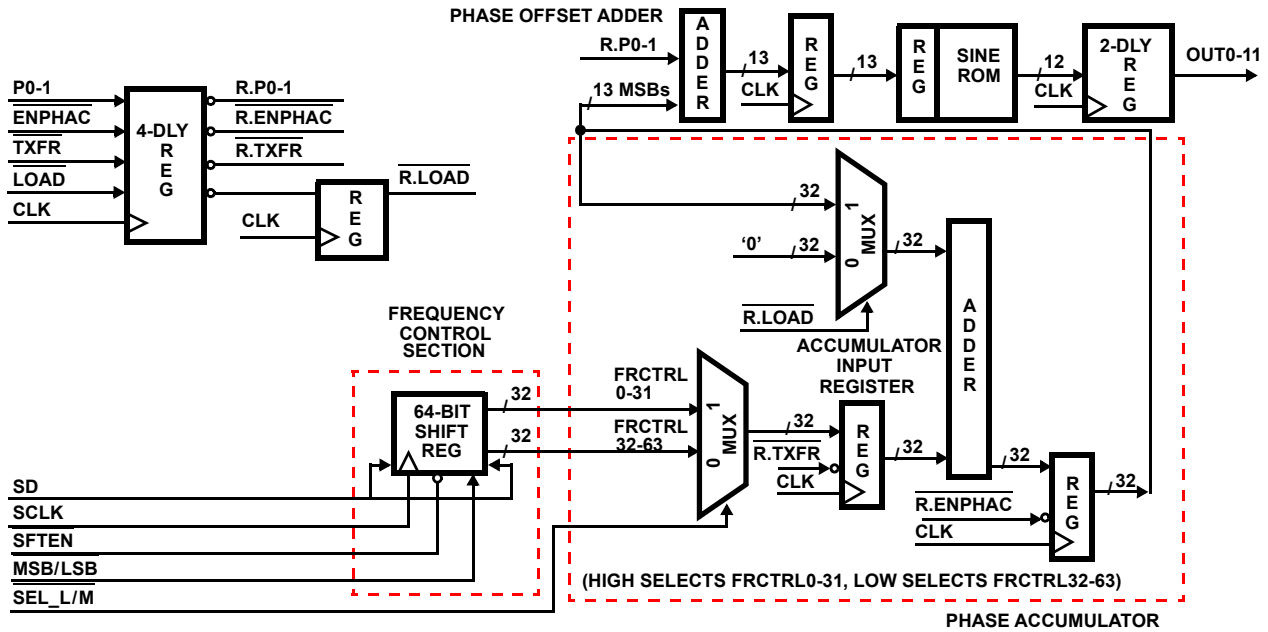

FIGURE 1. NCO-12 FUNCTIONAL BLOCK DIAGRAM

Functional Description

The NCO12 produces a 12-bit sinusoid whose frequency and phase are digitally controlled. The frequency of the sine wave is determined by one of two 32-bit words. Selection of the active word is made by SEL_L/M. The phase of the output is controlled by the two-bit input P0-1, which is used to select a phase offset of 0°, 90°, 180°, or 270°.

As shown in the Block Diagram, the NCO12 consists of a Frequency Control Section, a Phase Accumulator, a Phase Offset Adder and a Sine ROM. The Frequency Control section serially loads the frequency control word into the frequency register. The Phase Accumulator and Phase Offset Adder compute the phase angle using the frequency control word and the two phase modulation inputs. The Sine ROM generates the sine of the computed phase angle. The format of the 12-bit output is offset binary.

Frequency Control Section

The Frequency Control Section shown in Figure 1 serially loads the frequency data into a 64-bit, bidirectional shift register. The shift direction is selected with the MSB/LSB input. When this input is high, the frequency control word on the SD input is shifted into the register MSB first. When MSB/LSB is low the data is shifted in LSB first. The register shifts on the rising edge of SCLK when SFTEN is low. The timing of these signals is shown in Figures 2A and 2B.

The 64 bits of the frequency register are sent to the Phase Accumulator Section where 32 bits are selected to control the frequency of the sinusoidal output.

Phase Accumulator Section

The phase accumulator and phase offset adder compute the phase of the sine wave from the frequency control word and the phase modulation bits P0-1. The architecture is shown in Figure 1. The most significant 13 bits of the 32-bit phase accumulator are summed with the two-bit phase offset to generate the 13-bit phase input to the Sine Rom. A value of 0 corresponds to 0°, a value of 1000 hexadecimal corresponds to a value of 180°.

The phase accumulator advances the phase by the amount programmed into the frequency control register. The output frequency is equal to:

$$f_{LO} = (N \times f_{CLK} / 2^{32}), \text{ or} \tag{EQ. 1}$$

$$N = \text{INT} \left[\left(\frac{f_{OUT}}{f_{CLK}} \right) 2^{32} \right], \tag{EQ. 2}$$

where N is the 32 bits of frequency control word that is programmed. INT[*] is the integer of the computation. For example, if the control word is 20000000 hexadecimal and the clock frequency is 30MHz, then the output frequency would be $f_{CLK}/8$, or 3.75MHz.

The frequency control multiplexer selects the least significant 32 bits from the 64-bit frequency control register when SEL_L/M is high, and the most significant 32 bits when SEL_L/M is low. When only one frequency word is desired, SEL_L/M and MSB/LSB must be either both high or both low. This is due to the fact that when a frequency control word is loaded into the shift register LSB first, it enters through the most significant bit of the register. After 32 bits have been

shifted in, they will reside in the 32 most significant bits of the 64-bit register.

When $\overline{\text{TXFR}}$ is asserted, the 32 bits selected by the frequency control multiplexer are clocked into the phase accumulator input register. At each clock, the contents of this register are summed with the current contents of the accumulator to step to the new phase. The phase accumulator stepping may be inhibited by holding ENPHAC high. The phase accumulator may be loaded with the value in the input register by asserting LOAD, which zeroes the feedback to the phase accumulator.

The phase adder sums the encoded phase modulation bits P0-1 and the output of the phase accumulator to offset the phase by 0°, 90°, 180° or 270°. The two bits are encoded to produce the phase mapping shown in Table 1. This phase mapping is provided for direct connection to the in-phase and quadrature data bits for QPSK modulation.

TABLE 1. PHASE MAPPING

P0-1 CODING		
P1	P0	PHASE SHIFT (DEGREES)
0	0	0
0	1	90
1	0	270
1	1	180

ROM Section

The ROM section generates the 12-bit sine value from the 13-bit output of the phase adder. The output format is offset binary and ranges from 001 to FFF hexadecimal, centered around 800 hexadecimal.

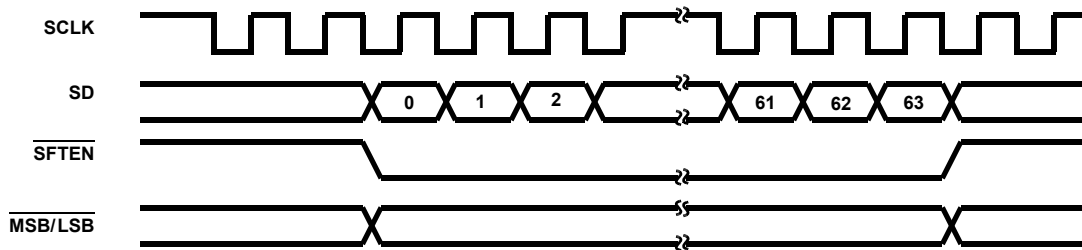

FIGURE 2A. FREQUENCY LOADING ENABLED BY $\overline{\text{SFTEN}}$

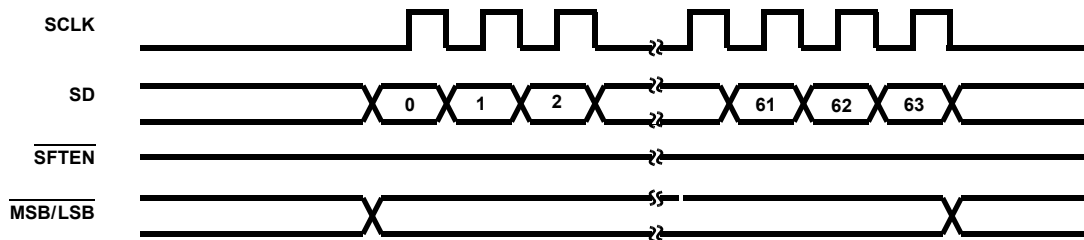

FIGURE 2B. FREQUENCY LOADING CONTROLLED BY SCLK

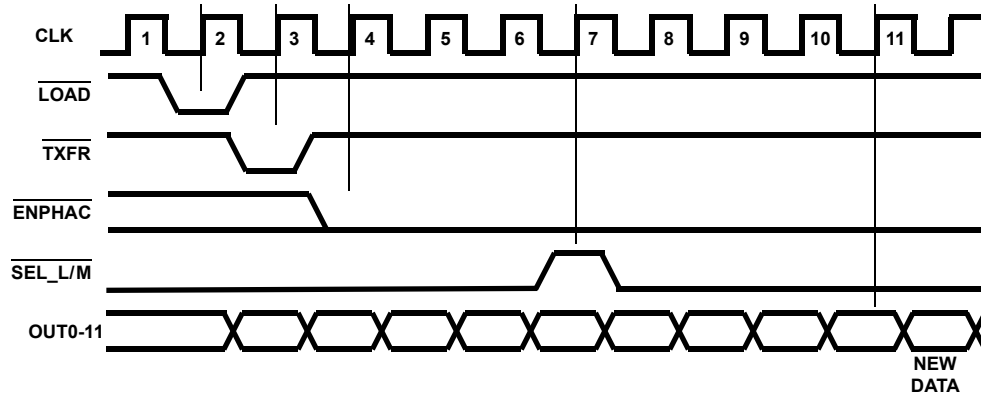

FIGURE 3. I/O TIMING

Absolute Maximum Ratings $T_A = +25^\circ\text{C}$

Supply Voltage +6.0V
 Input, Output or I/O Voltage Applied GND -0.5V to $V_{CC} + 0.5\text{V}$
 ESD Classification Class 1

Operating Conditions

Operating Voltage Range (Commercial, Industrial) .. +4.75V to +5.25V
 Operating Temperature Range (Commercial) 0°C to $+70^\circ\text{C}$
 Operating Temperature Range (Industrial) -40°C to $+85^\circ\text{C}$

CAUTION: Stresses above those listed in "Absolute Maximum Ratings" may cause permanent damage to the device. This is a stress only rating and operation of the device at these or any other conditions above those indicated in the operational sections of this specification is not implied.

NOTE:

- θ_{JA} is measured with the component mounted on an evaluation PC board in free air.

Thermal Information

Thermal Resistance (Typical, Note 1) θ_{JA} ($^\circ\text{C}/\text{W}$)
 SOIC Package 70
 Maximum Junction Temperature $+150^\circ\text{C}$
 Maximum Storage Temperature Range -65°C to $+150^\circ\text{C}$
 Pb-free reflow profile see TB493

Die Characteristics

Backside Potential V_{CC}

DC Electrical Specifications

PARAMETER	SYMBOL	TEST CONDITIONS	MIN	MAX	UNITS
Logical One Input Voltage	V_{IH}	$V_{CC} = 5.25\text{V}$	2.0	-	V
Logical Zero Input Voltage	V_{IL}	$V_{CC} = 4.75\text{V}$	-	0.8	V
High Level Clock Input	V_{IHC}	$V_{CC} = 5.25\text{V}$	3.0	-	V
Low Level Clock Input	V_{ILC}	$V_{CC} = 4.75\text{V}$	-	0.8	V
Output HIGH Voltage	V_{OH}	$I_{OH} = -400\mu\text{A}$, $V_{CC} = 4.75\text{V}$	2.6	-	V
Output LOW Voltage	V_{OL}	$I_{OL} = +2.0\text{mA}$, $V_{CC} = 4.75\text{V}$	-	0.4	V
Input Leakage Current	I_I	$V_{IN} = V_{CC}$ or GND, $V_{CC} = 5.25\text{V}$	-10	10	μA
Standby Power Supply Current	I_{CCSB}	$V_{IN} = V_{CC}$ or GND, $V_{CC} = 5.25\text{V}$, Note 4	-	500	μA
Operating Power Supply Current	I_{CCOP}	$f = 33\text{MHz}$, $V_{IN} = V_{CC}$ or GND $V_{CC} = 5.25\text{V}$, Notes 2 and 4	-	99	mA

Capacitance $T_A = +25^\circ\text{C}$, Note 3

PARAMETER	SYMBOL	TEST CONDITIONS	MIN	MAX	UNITS
Input Capacitance	C_{IN}	FREQ = 1MHz, $V_{CC} = \text{Open}$. All measurements are referenced to device ground	-	10	pF
Output Capacitance	C_O		-	10	pF

NOTES:

- Power supply current is proportional to operating frequency. Typical rating for I_{CCOP} is 3mA/MHz.
- Not tested, but characterized at initial design and at major process/design changes.
- Output load per test load circuit with switch open and $C_L = 40\text{pF}$.

AC Electrical Specifications $V_{CC} = 5.0V \pm 5\%$, $T_A = 0^\circ C$ to $+70^\circ C$, $T_A = -40^\circ C$ to $+85^\circ C$ (Note 5)

PARAMETER	SYMBOL	NOTES	-33 (33MHz)		-40 (40MHz)		UNITS
			MIN	MAX	MIN	MAX	
Clock Period	t_{CP}		30	-	25	-	ns
Clock High	t_{CH}		12	-	10	-	ns
Clock Low	t_{CL}		12	-	10	-	ns
SCLK High/Low	t_{SW}		12	-	10	-	ns
Setup Time SD to SCLK Going High	t_{DS}		12	-	12	-	ns
Hold Time SD from SCLK Going High	t_{DH}		0	-	0	-	ns
Setup Time \overline{SFTEN} , $\overline{MSB/LSB}$ to SCLK Going High	t_{MS}		15	-	12	-	ns
Hold Time \overline{SFTEN} , $\overline{MSB/LSB}$ from SCLK Going High	t_{MH}		0	-	0	-	ns
Setup Time SCLK High to CLK Going High	t_{SS}	Note 6	16	-	15	-	ns
Setup Time P0-1 to CLK Going High	t_{PS}		15	-	12	-	ns
Hold Time P0-1 from CLK Going High	t_{PH}		1	-	1	-	ns
Setup Time \overline{LOAD} , \overline{TXFR} , \overline{ENPHAC} , $\overline{SEL_L/M}$ to CLK Going High	t_{ES}		15	-	13	-	ns
Hold Time \overline{LOAD} , \overline{TXFR} , \overline{ENPHAC} , $\overline{SEL_L/M}$ from CLK Going High	t_{EH}		1	-	1	-	ns
CLK to Output Delay	t_{OH}		2	15	2	13	ns
Output Rise, Fall Time	t_{RF}	Note 7	8	-	8	-	ns

NOTES:

- AC testing is performed as follows: Input levels (CLK Input) 4.0V and 0V; Input levels (all other inputs) 0V and 3.0V; Timing reference levels (CLK) 2.0V; All others 1.5V. Output load per test load circuit with switch closed and $C_L = 40pF$. Output transition is measured at $V_{OH} > 1.5V$ and $V_{OL} < 1.5V$.
- If TXFR is active, care must be taken to not violate setup and hold times as data from the shift registers may not have settled before CLK occurs.
- Controlled via design or process parameters and not directly tested. Characterized upon initial design and after major process and/or design changes.

AC Test Load Circuit

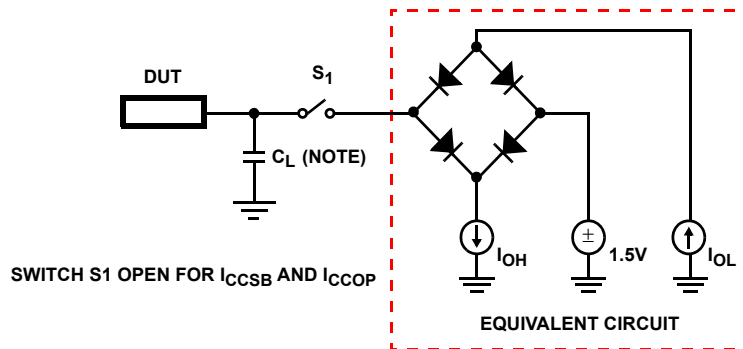

NOTE: Test head capacitance.

Waveforms

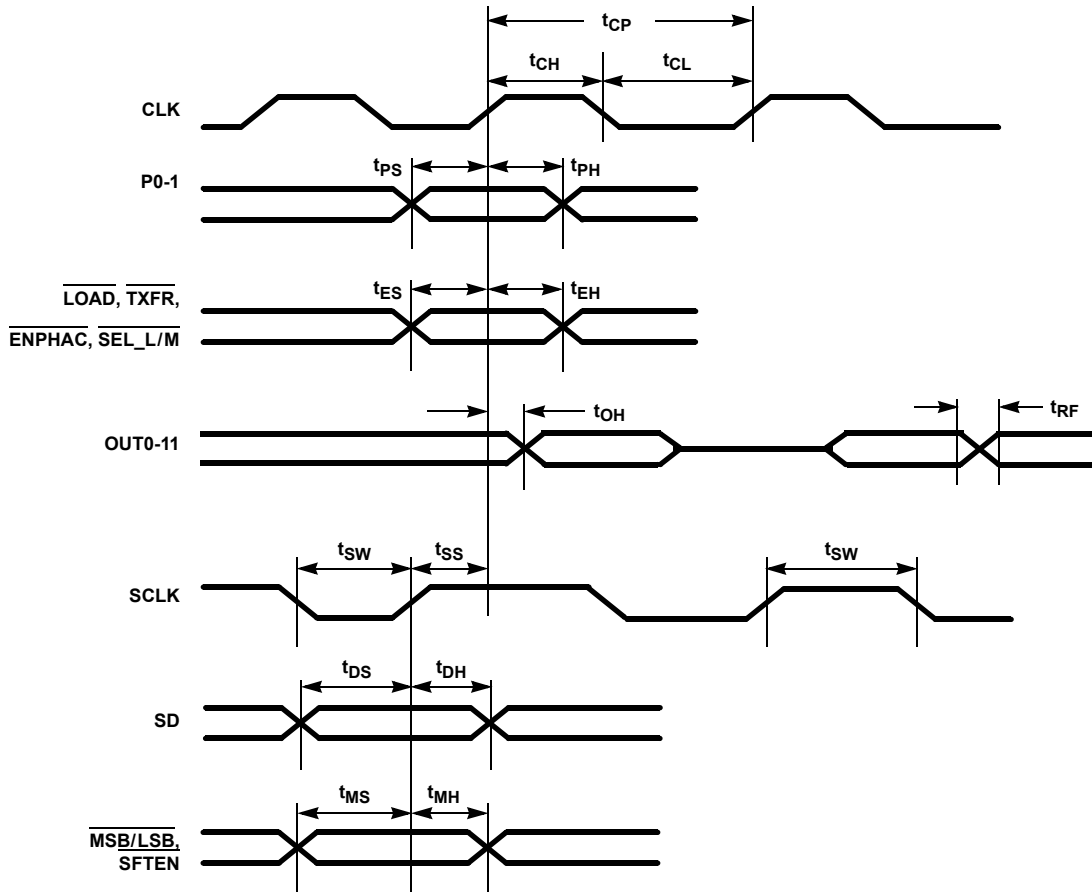

FIGURE 4.

Revision History

Rev.	Date	Description
9.01	Jan 28, 2020	Updated Ordering Information. Added Revision History table. Updated POD M28.3 from rev 0 to rev 1. Changes: - Added land pattern Updated Disclaimer.

Small Outline Plastic Packages (SOIC)

For the most recent package outline drawing, see [M28.3](#).

**M28.3 (JEDEC MS-013-AE ISSUE C)
28 LEAD WIDE BODY SMALL OUTLINE PLASTIC PACKAGE**

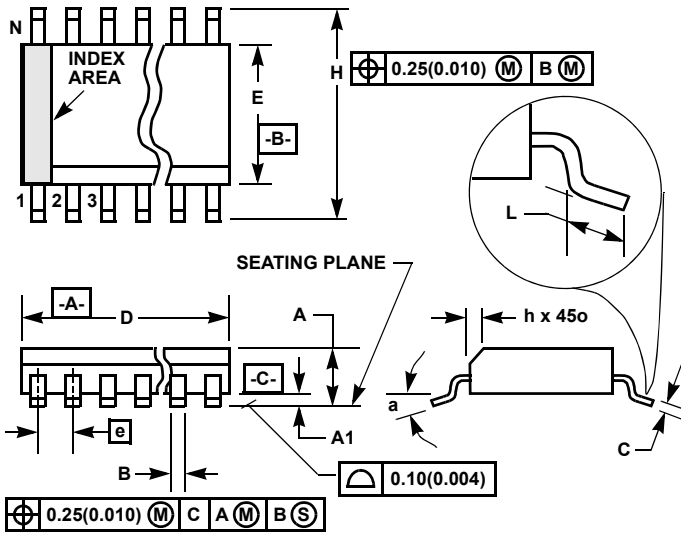

SYMBOL	INCHES		MILLIMETERS		NOTES
	MIN	MAX	MIN	MAX	
A	0.0926	0.1043	2.35	2.65	-
A1	0.0040	0.0118	0.10	0.30	-
B	0.013	0.0200	0.33	0.51	9
C	0.0091	0.0125	0.23	0.32	-
D	0.6969	0.7125	17.70	18.10	3
E	0.2914	0.2992	7.40	7.60	4
e	0.05 BSC		1.27 BSC		-
H	0.394	0.419	10.00	10.65	-
h	0.01	0.029	0.25	0.75	5
L	0.016	0.050	0.40	1.27	6
N	28		28		7
α	0°	8°	0°	8°	-

Rev. 1, 1/13

NOTES:

1. Symbols are defined in the "MO Series Symbol List" in Section 2.2 of Publication Number 95.
2. Dimensioning and tolerancing per ANSI Y14.5M-1982.
3. Dimension "D" does not include mold flash, protrusions or gate burrs. Mold flash, protrusion and gate burrs shall not exceed 0.15mm (0.006 inch) per side.
4. Dimension "E" does not include interlead flash or protrusions. Interlead flash and protrusions shall not exceed 0.25mm (0.010 inch) per side.
5. The chamfer on the body is optional. If it is not present, a visual index feature must be located within the crosshatched area.
6. "L" is the length of terminal for soldering to a substrate.
7. "N" is the number of terminal positions.
8. Terminal numbers are shown for reference only.
9. The lead width "B", as measured 0.36mm (0.014 inch) or greater above the seating plane, shall not exceed a maximum value of 0.61mm (0.024 inch)
10. Controlling dimension: MILLIMETER. Converted inch dimensions are not necessarily exact.

TYPICAL RECOMMENDED LAND PATTERN

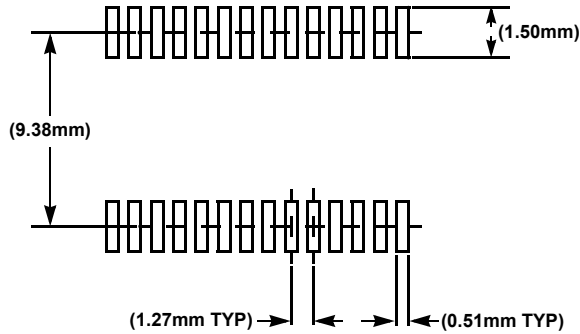

IMPORTANT NOTICE AND DISCLAIMER

RENESAS ELECTRONICS CORPORATION AND ITS SUBSIDIARIES (“RENESAS”) PROVIDES TECHNICAL SPECIFICATIONS AND RELIABILITY DATA (INCLUDING DATASHEETS), DESIGN RESOURCES (INCLUDING REFERENCE DESIGNS), APPLICATION OR OTHER DESIGN ADVICE, WEB TOOLS, SAFETY INFORMATION, AND OTHER RESOURCES “AS IS” AND WITH ALL FAULTS, AND DISCLAIMS ALL WARRANTIES, EXPRESS OR IMPLIED, INCLUDING, WITHOUT LIMITATION, ANY IMPLIED WARRANTIES OF MERCHANTABILITY, FITNESS FOR A PARTICULAR PURPOSE, OR NON-INFRINGEMENT OF THIRD PARTY INTELLECTUAL PROPERTY RIGHTS.

These resources are intended for developers skilled in the art designing with Renesas products. You are solely responsible for (1) selecting the appropriate products for your application, (2) designing, validating, and testing your application, and (3) ensuring your application meets applicable standards, and any other safety, security, or other requirements. These resources are subject to change without notice. Renesas grants you permission to use these resources only for development of an application that uses Renesas products. Other reproduction or use of these resources is strictly prohibited. No license is granted to any other Renesas intellectual property or to any third party intellectual property. Renesas disclaims responsibility for, and you will fully indemnify Renesas and its representatives against, any claims, damages, costs, losses, or liabilities arising out of your use of these resources. Renesas' products are provided only subject to Renesas' Terms and Conditions of Sale or other applicable terms agreed to in writing. No use of any Renesas resources expands or otherwise alters any applicable warranties or warranty disclaimers for these products.

(Rev.1.0 Mar 2020)

Corporate Headquarters

TOYOSU FORESIA, 3-2-24 Toyosu,
Koto-ku, Tokyo 135-0061, Japan
www.renesas.com

Contact Information

For further information on a product, technology, the most up-to-date version of a document, or your nearest sales office, please visit:
www.renesas.com/contact/

Trademarks

Renesas and the Renesas logo are trademarks of Renesas Electronics Corporation. All trademarks and registered trademarks are the property of their respective owners.



Компания «ЭлектроПласт» предлагает заключение долгосрочных отношений при поставках импортных электронных компонентов на взаимовыгодных условиях!

Наши преимущества:

- Оперативные поставки широкого спектра электронных компонентов отечественного и импортного производства напрямую от производителей и с крупнейших мировых складов;
- Поставка более 17-ти миллионов наименований электронных компонентов;
- Поставка сложных, дефицитных, либо снятых с производства позиций;
- Оперативные сроки поставки под заказ (от 5 рабочих дней);
- Экспресс доставка в любую точку России;
- Техническая поддержка проекта, помощь в подборе аналогов, поставка прототипов;
- Система менеджмента качества сертифицирована по Международному стандарту ISO 9001;
- Лицензия ФСБ на осуществление работ с использованием сведений, составляющих государственную тайну;
- Поставка специализированных компонентов (Xilinx, Altera, Analog Devices, Intersil, Interpoint, Microsemi, Aeroflex, Peregrine, Syfer, Eurofarad, Texas Instrument, Miteq, Cobham, E2V, MA-COM, Hittite, Mini-Circuits, General Dynamics и др.);

Помимо этого, одним из направлений компании «ЭлектроПласт» является направление «Источники питания». Мы предлагаем Вам помощь Конструкторского отдела:

- Подбор оптимального решения, техническое обоснование при выборе компонента;
- Подбор аналогов;
- Консультации по применению компонента;
- Поставка образцов и прототипов;
- Техническая поддержка проекта;
- Защита от снятия компонента с производства.



Как с нами связаться

Телефон: 8 (812) 309 58 32 (многоканальный)

Факс: 8 (812) 320-02-42

Электронная почта: org@eplast1.ru

Адрес: 198099, г. Санкт-Петербург, ул. Калинина, дом 2, корпус 4, литера А.