

## WIDE BAND FM IF DEMODULATOR

### ■ GENERAL DESCRIPTION

The **NJM2549** is a wide band IF IC with a maximum IF input frequency of 15 MHz. It includes an IF Amplifier, Quadrature Detector, RSSI and IF Balanced Output.

### ■ PACKAGE OUTLINE

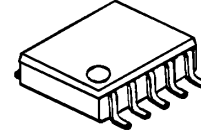

**NJM2549RB2**

### ■ MAIN APPLICATIONS

- RF ID
- Radar detector
- Wireless Infrared Communication System
- Voice Transmission System
- A few MHz band Signal Detector

### ■ FEATURES

- |                                     |   |
|-------------------------------------|---|
| ● Wide Range Operating Voltage      | 2.7V to 9V (recommended supply voltage)                 |
| ● Low Operating Current             | 3mA (standard)  |
| ● Wide Range IF Input Frequency     | 10.7MHz (standard)<br>100kHz to 15MHz (reference value) |
| ● Wide Band FM Detector Range       | DC to 1MHz (reference value)                            |
| ● RSSI Quick Response               |   |
| ● High FM Detection Sensitivity     | 22dBuV (- 3dB Limiting Sensitivity)                     |
| ● IF Amplifier with Balanced Output |   |
| ● Bipolar Technology                |   |
| ● Package Outline                   | TVSP10  |

### ■ BLOCK DIAGRAM

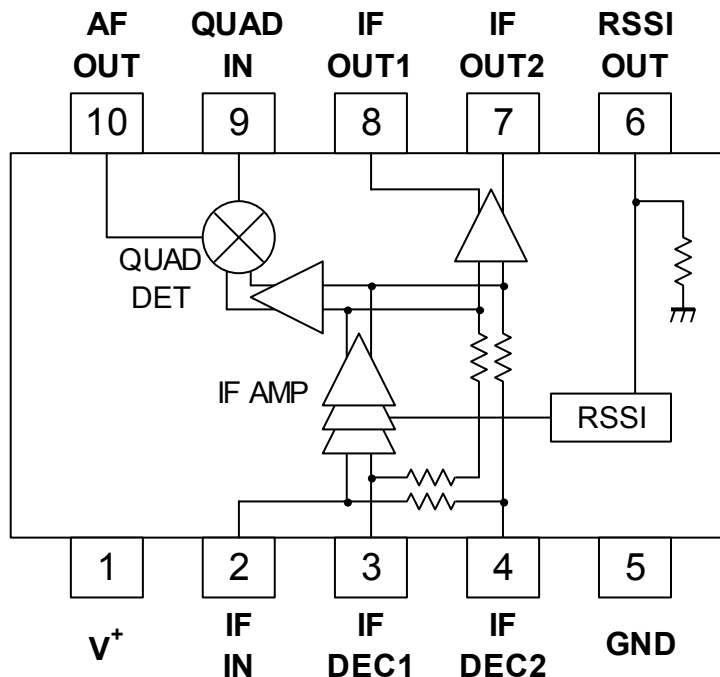

■ EXPLANATION

Functional Block Diagram

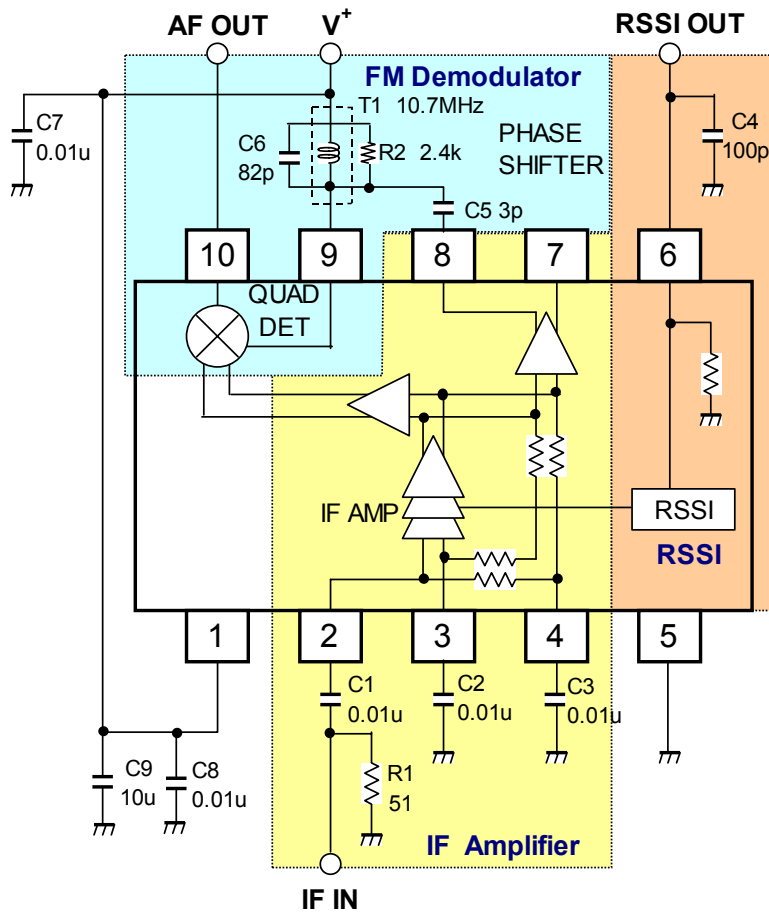

General

The frequency- converted RF signal goes through an external narrow or wide bandwidth BPF and is inputted to Pin 2 as unbalanced input, otherwise inputted to Pin2 and Pin3 as balanced input. The available frequency range of IF signals are from 100kHz to 15MHz. The IF amplifier is a limiting amplifier with 75dB gain and converts IF input signal to an amplitude - limiting IF signal. The FM demodulator consists of an external phase shifter circuit and an internal quadrature detector. It demodulates the amplitude - limiting IF signal and outputs to Pin10 as AF output signal. The demodulated AF output signal is the rail-to-rail output of 2.7Vpp with the maximum bandwidth of up to 1MHz. Pin6 is the output of RSSI circuit, which outputs DC level proportional to the log of input signal level to Pin 2. NJM2549 has other remarkable functions: balanced input/ output (Pins 2, 3, 7and 8), and pin-selectable for either of two demodulation characteristics (Pin7and 8).

IF Amplifier (Pins 2, 3, 4, 7, and 8)

Input impedance

Pin2 and Pin 3 are the input terminal for IF input signal. Pin2 is used for unbalanced input, and a pair of Pin 2 and Pin3 is used for balanced input. As one general example of unbalanced input, IF signal is supplied to Pin 2 through an external band-pass filter and a matching resistor R1 in parallel. In general, the matching impedance of the filter is 330ohm. Pin 2 is designed to have input impedance of 10kohm much higher than 330ohm, and R1 should be 330ohm

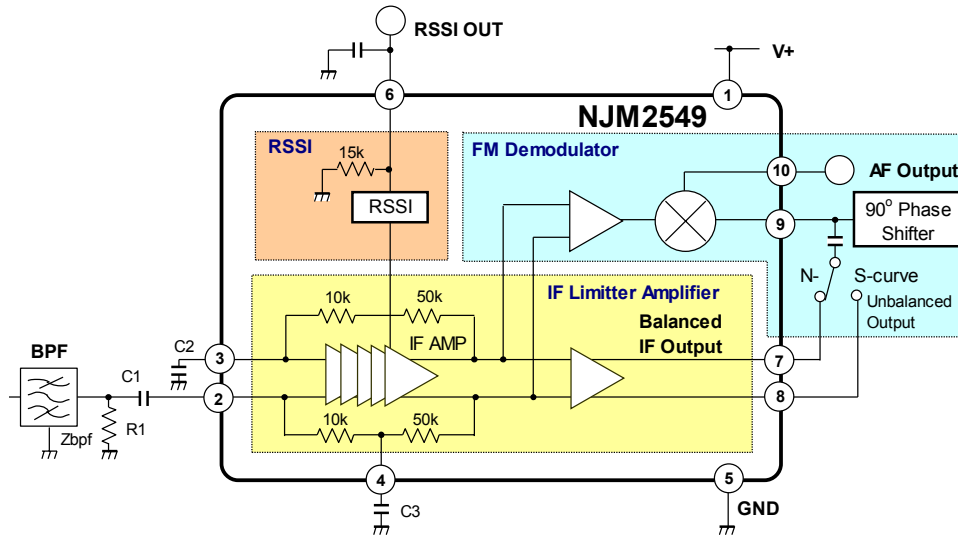

as the same value of the matching impedance. When you connect measurement equipment to Pin2, recommended value of R1 is 50ohm that is the same value of output impedance of the equipment.

For the case of unbalanced input, a decoupling capacitor C2 is necessary to locate between Pin 3 and GND line. The impedance of this decoupling capacitor should be adequately low at IF frequency to keep Pin3 close to the GND line level of NJM2549. Note that for larger value of decoupling capacitance, startup-waiting time of operating voltage is longer because of larger time constant formed by the capacitance and the input impedance of Pin3. For your reference, our evaluation board uses 0.01uF for 10.7MHz IF frequency.

**Gain**

IF limiter amplifier is a six-stage differential amplifier with balanced inputs of Pin2 and Pin3. The IF input signal is amplified and then supplied to both of the internal quadrature detector and the external phase shifter of FM demodulation circuit. Total gain of the IF limiter amplifier is so high value, approximately 75dB at 10.7Hz that the output signal is an amplitude-limiting signal. This output signal is like a square wave that is required for the normal operation of FM demodulation.

The gain is changed by the IF input frequency and the value of the external capacitors of C1, C2 and C3, as shown in the figure. It is recommended that these three capacitors have the same values in capacitance to harmonize each startup-waiting time of operating voltage. C1 is a DC cut capacitor. C2 is a decoupling capacitor when pin2 is unbalanced input. C3 is a noise removal capacitor to remove noise on the resistor feedback path.

IF AMP Gain versus IF Frequency and Terminal Capacitance

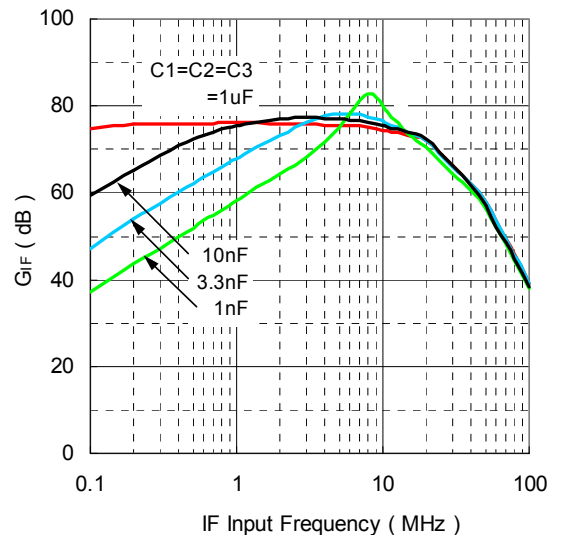

**Balanced input / output**

NJM2549 features balanced input. It is available to connect directly to the balanced output circuit that precedes NJM2549. When input signal is small so that output signal of IF amplifier is not limited amplitude, balanced input is effective to remove common noise from input signal. When FM demodulator circuit is not required and NJM2549 uses just for a high gain limiter amplifier, the balanced output can be available. This is effective to reduce the susceptibility of external noise while allowing the usage of longer line between the output terminals and the next stage.

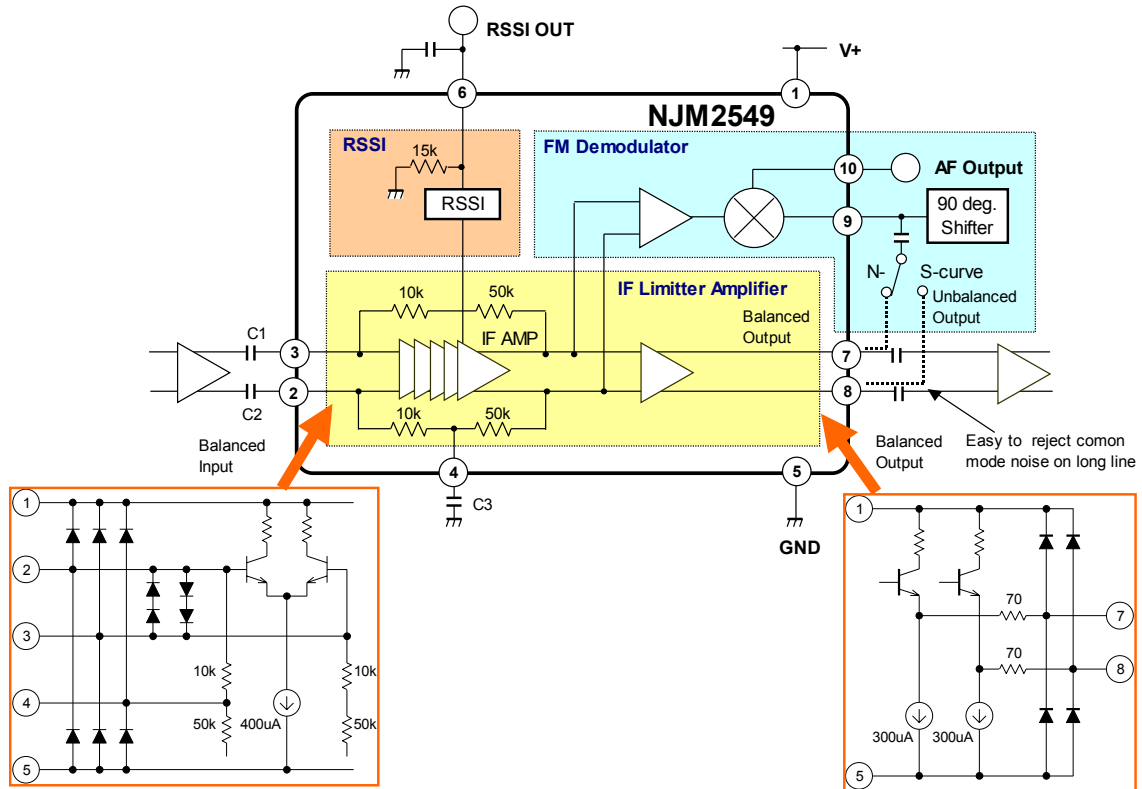

**Output level at pin7and pin8**

The output level at each of Pin7and Pin8 is Typ.425mVpp with the external load resistor RL of 15kohm connected from output to ground under the standard measurement condition. In order to avoid over current and obtain desired output level, the external load resistor of over 15kohm is recommended for each pin. The output current is Typ.290mA under the same condition.

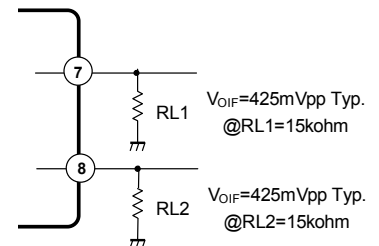

**FM Demodulator (Pins 7 to 10)**

The signal from IF amplifier is put into the FM demodulator. The FM demodulator is composed of an internal quadrature detector and an external phase shifter. The quadrature detector is a multiplier and needs two kinds of input signal. One is the original IF signal including a carrier signal and a FM modulated signal. The other is 90-degree shifted IF signal, which is the output of the phase shifter. The demodulated signal from the quadrature detector is brought out at Pin 10. Note that the supply voltage to phase-shifter should be the same as the supply voltage to Pin 1.

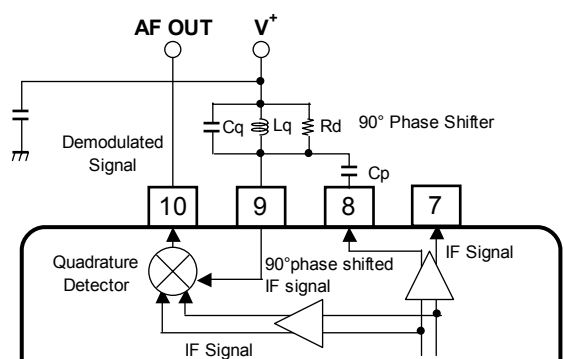

**Phase shifter**

The phase shifter is an external circuit that is composed of a capacitor and RLC resonant circuit. The capacitor is placed between Pin9 and Pin8 (or between Pin9 and Pin7) to increase the IF signal to the external parallel RLC resonant circuit that provides the 90-degree phase shift and drives the quadrature detector. Pin 9 provides for the external RLC parallel resonant circuit and the internal connection to the quadrature detector. Instead of LC resonant circuit, a ceramic discriminator can be also used and it is very useful to delete a frequency adjustment and obtain higher Q. The resonant frequency of the ceramic discriminator or the LC resonant circuit is the same as IF frequency of IF input signal. In general,

most of ceramic discriminators are designed for the specific ICs to optimize some important performance of the FM demodulator.

The ceramic discriminator CD: CDSCB10MGA144-R0 (Murata Manufacturing Co., Ltd., Japan) is especially designed for NJM2549, when using IF frequency of 10.7MHz. Pin9 needs bias through a resistor. The bias voltage should be the same as the supply voltage V+. When the detector is not used, Pin9 should be connected to V+. The resistor Rd is not only used for bias but also for the adjustment of the important characteristics of the detector circuit.

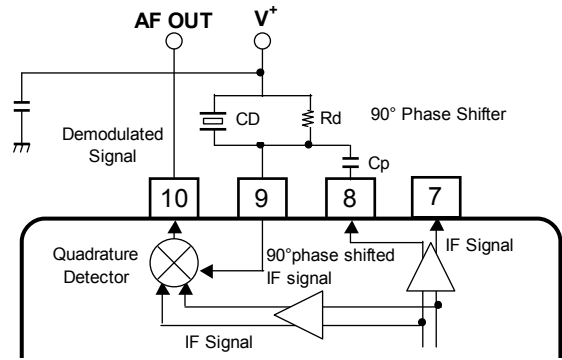

**S-curve**

The S-curve is the characteristics of “detector output level versus IF frequency deviation”. This characteristic is determined by the performance of the phase shifter.

The following mentions how to determine the value of the phase shifter. The quadrature detector is coupled to the IF with and a capacitor Cp between Pin9 and Pin8 (or between Pin9 and Pin7). For wideband applications, the drive to the detector can be increased with this additional external capacitor and the demodulated signal level output is increased for a given bandwidth. The wideband performance of the detector is controlled by the loaded Q of the LC tank circuit. The following equation defines the components which set the detector circuit’s bandwidth:

$$Q=R_d / X$$

where Rd is the equivalent shunt resistance across the LC tank. X is the reactance of the quadrature inductor at the IF frequency ( $X=2 \pi f_{if} L$ ). The inductor and capacitor are chosen to form a resonant LC tank at the desired IF center frequency as predicated by;

$$f_{if} = \frac{1}{2 \pi \sqrt{L_q C_q}}$$

where Ld is the parallel tank inductor, C9 is the equivalent parallel capacitance of the parallel resonant tank circuit.

The following is one of the examples of actual step to obtain the suitable values of Cp, Cq, Lq and R.

1. Determine the value of Cq and Lq from the relative expression as shown above. It is very convenient to use an IF transformer with built-in Cq, which has high Q and the resonance frequency of f<sub>if</sub>.
2. Add a capacitor of a few pF as Cp and measure S-curve. Change Cp until the center frequency of S-curve comes to the resonance frequency of f<sub>if</sub>
  - a. Considering the following items, choose Rd.
  - b. The position of f<sub>if</sub> is at the center of S-curve
  - c. The position of f<sub>if</sub>-Δf and f<sub>if</sub>+Δf is on the linear area of S-curve.
  - d. The frequency stability and accuracy of received RF signal and local signal are influenced to the stability of IF signal.
  - e. If the stability is not so good, the position of f<sub>if</sub>-Δf should be located far from the bottom of S-curve. The position of f<sub>if</sub>+Δf should be also located far from the top of S-curve.

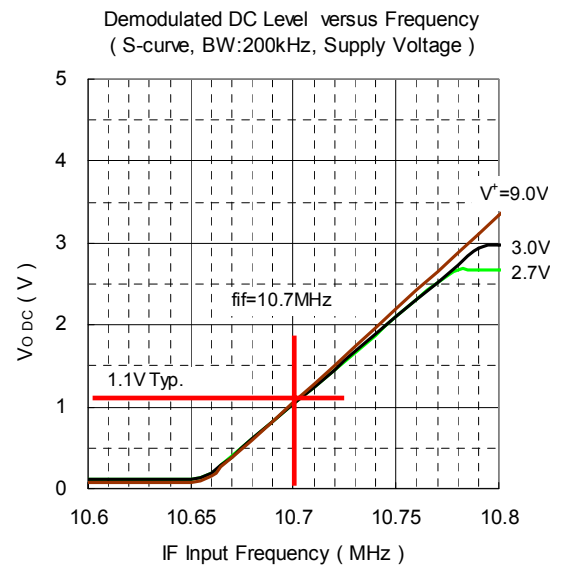

In next page, there is a drawing that shows how to adjust S-curve to obtain the suitable demodulated signal.

**What determines its position and tilt angle of S-curve**

**Q and Rd**

As the loaded Q of the LC tank circuit and Rd of shunt resistance across the LC tank become large, the tilt angle of S-curve increases.

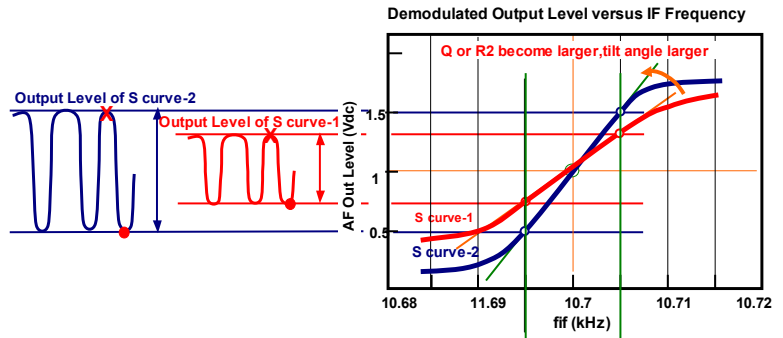

**Cp**

As the capacitor Cp between Pin9 and Pin8 (or between Pin9 and Pin7) becomes small, the S-curve shifts to the right side.

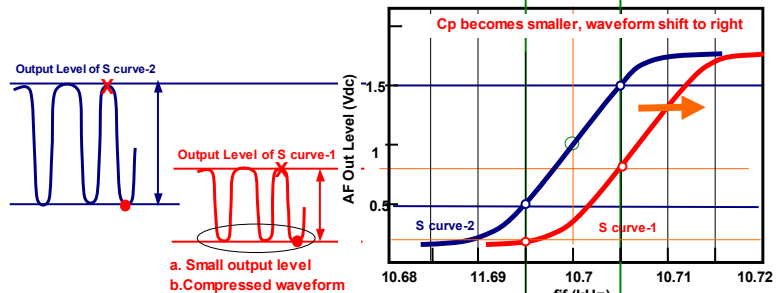

The carrier of FM modulation signal moves from  $f_{if}-f_{dev}$  to  $f_{if}+f_{dev}$ . Total width of FM deviation is the double of  $f_{dev}$ . When the width of FM deviation is within the linear area of S-curve, FM demodulation is done well. If the width of FM deviation is too large and the frequency of  $f_{if}-f_{dev}$  and  $f_{if}+f_{dev}$  is out of the linear area, FM demodulation is not done well. Or you have to change Rd or Q of tank circuit to make the linear area wider. For example, if the center frequency of IF input signal is 10.7MHz and maximum FM deviation is  $\pm 5$ kHz, FM demodulated signal has the frequency range of 10.695MHz to 10.705MHz. This frequency range is within the linear area of S-curve-0. If the maximum FM deviation is  $\pm 10$ kHz, this signal will move from 10.69MHz to 10.71MHz. This signal is demodulated on the non-linear area and may have big distortion. Changing the value of the external resistor Rd and Q of the tank circuit, the width of linear area on the S-curve can be adjusted, as shown as S curve-1. When the linear area becomes wider, the demodulated output level becomes smaller because tilt angle of S-curve smaller. In the case of  $\pm 50$ kHz of FM deviation, it is difficult to have such a wide linear area from 10.65MHz to 10.75MHz by reducing the value of the external resistor.

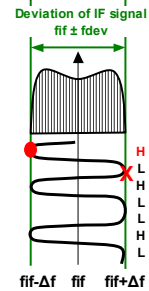

**How to measure S-curve characteristics**

**Connection**

- Signal Generator : R&S SMY02
- Multi-meter : Digital volt meter with high input impedance
- Power supply

**How to measure**

1. Set supply voltage of Power supply
2. Set RF output level and IF frequency (fif) of Signal generator
3. Set DCV mode of Mutimeter
4. Supply DC voltage to evaluation board
5. Change IF frequency from  $f_{if} - 15$ kHz (or 20kHz) to  $f_{if} + 15$ kHz (or 20kHz) by 1kHz step
6. Read output DC voltage of multimeter by each IF frequency

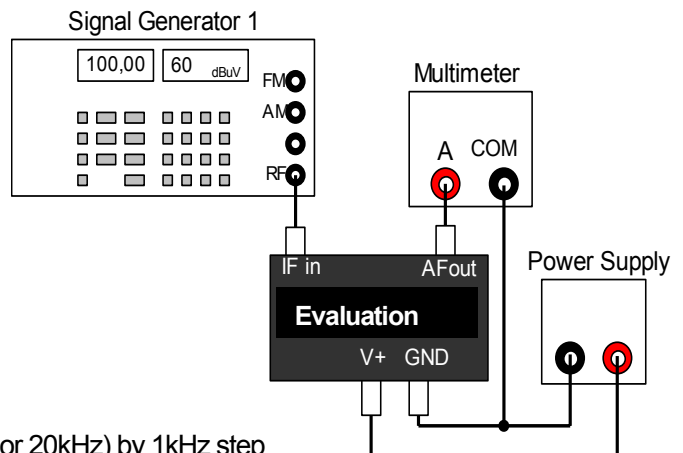

**Selectable two modes of S-curve or N-curve**

The characteristics of “detector output level versus IF frequency deviation ” is available in two modes selectable via Pin7 and Pin8. One is, as explained, S-curve and the other is N-curve. The S-curve characteristic features S-like shape of the curve. So we call “S-curve”. According to the S-curve characteristic, as the frequency of IF carrier signal goes up, the AF output level increase. On the other hand, the N-curve characteristic features N-like shape of the curve, and the AF output level increase as the IF carrier frequency goes down.

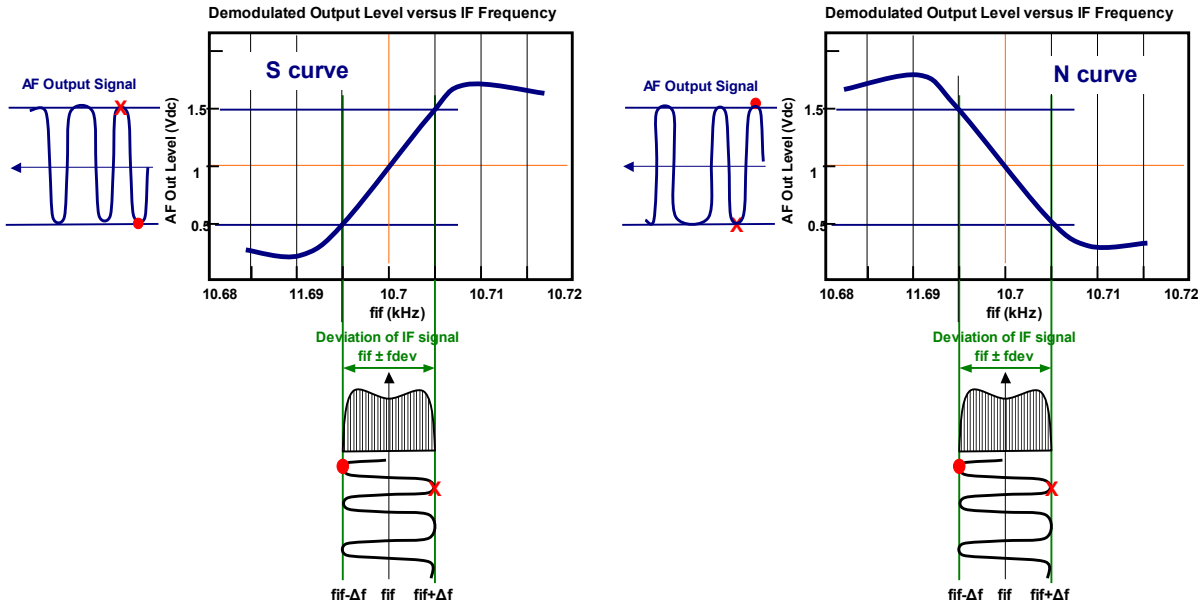

Pin 7 is a select pin for N curve, and pin8 is for S curve. It is recommended that you leave unused pin (Pin7 or Pin8) unconnected on the board, otherwise, terminated with resistor which value is the same as the load impedance of the used pin.

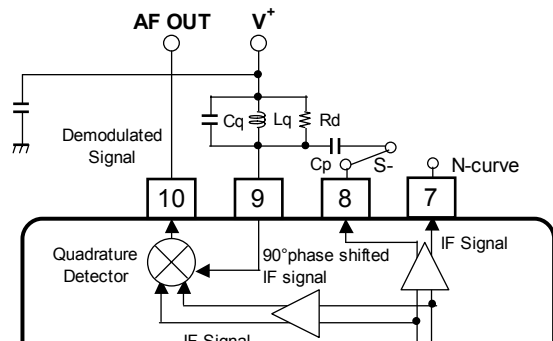

**AF output level**

The FM demodulated signal from the quadrature detector is brought out at Pin 10. AF output level at Pin10 is determined by deviation of IF signal, tilt angle of S-curve, external load resistance connected to Pin10 and supply voltage. The figure is the S-curve of NJM2549 measured under our standard test condition. The resulting curve shows how external resistor of R2 effects the tilt angle of S-curve and the expected maximum output level at Pin10, where R2 is an external resistor of FM demodulator used as the same meaning of Rd.

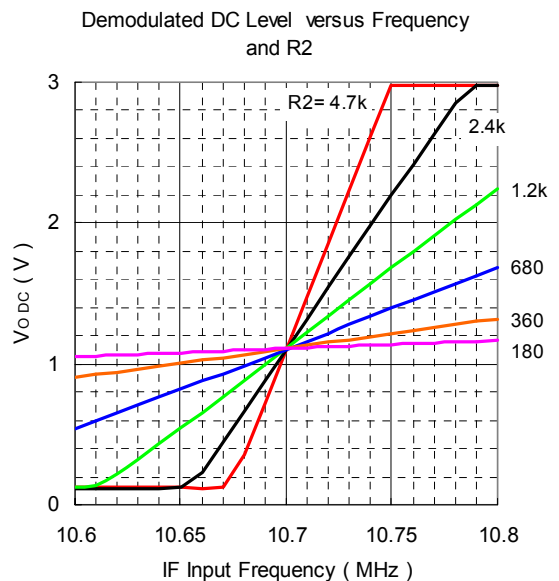

The maximum output level is approximately 90% of supply voltage under the following condition:

$$R_L > V^+ / 205\mu A$$

where  $R_L$  is the value of external load resistance connected to pin10. It is important to set DC level of detector output at Pin10 to center the peak-to-peak swing of the demodulated signal. In addition, tilt angle of S-curve should be high enough to obtain large output level.

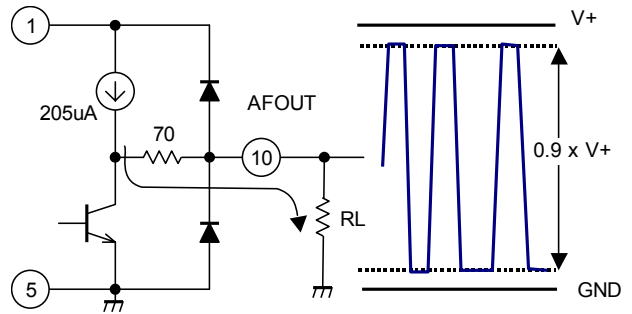

**LPF for removing noise from AF output signal**

The frequency bandwidth of demodulated signal is up to 1000kHz under the standard measurement condition of NJM2549. This performance is much enough to use for low bit-rate data demodulation. On the other hand, AF output signal contains the factor of IF carrier signal and many harmonics and these noise factors exacerbate S/N (signal to noise ratio). A by-pass capacitor is useful to remove these noise factors. The 3<sup>rd</sup>-multiple feedback filter is a low pass active filter and more effective to remove the factor of high frequency signal from the demodulated output signal. It is composed of three resistors, three capacitors and an amplifier. The cut-off frequency  $f_c$  of the filter is obtained by

$$f_c = \frac{1}{2 \pi \sqrt[3]{R_a R_b R_c C_a C_b C_c}} \text{ Hz} \quad \text{where } R_a=R_b=R_c \text{ or } C_a=C_b=C_c$$

In the case of digital data demodulation,  $f_c$  is determined by the following formula.

$$f_c = \frac{1}{2} \text{ Baud} \times (1.5 \text{ to } 2)$$

Examples of actual circuit are shown below.

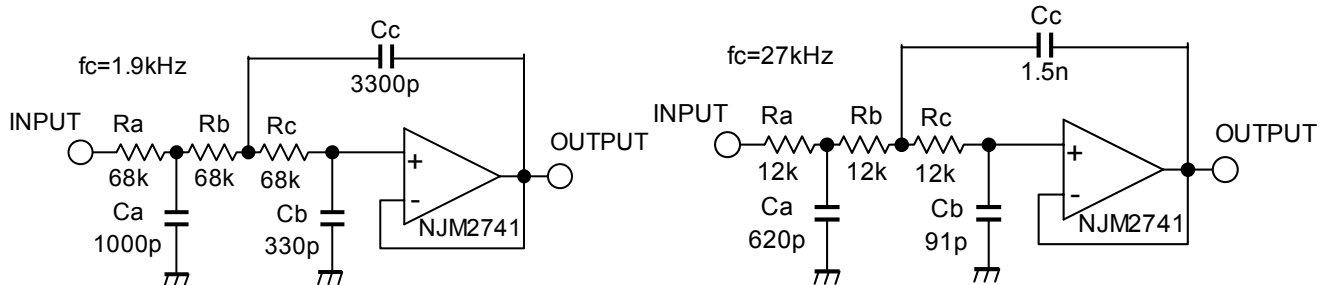

The following list shows an example of the external value.

bps	Ra	Rb	Rc	Ca	Cb	Cc	fc
512	68kΩ	68kΩ	68kΩ	8200pF	1200pF	0.022µF	390Hz
1200	68kΩ	68kΩ	68kΩ	3300pF	560pF	0.01µF	885Hz
2400	68kΩ	68kΩ	68kΩ	1500pF	330pF	3300pF	1.99kHz
3200	30kΩ	30kΩ	30kΩ	1500pF	680pF	4800pF	3.15kHz
6400	30kΩ	30kΩ	30kΩ	820pF	330pF	2200pF	6.31kHz

**Simplified FM demodulator circuit**

Limited to specific applications, simplified phase shifter circuit of FM demodulator may be available. You may reduce external components. For more information, please contact us.



**RSSI (Pin6)**

RSSI is a received signal strength indicator and outputs DC voltage, which voltage is proportional to the log of the IF signal amplitude. The internal resistance at pin 6 is around 15k ohm and RSSI output is voltage mode. The RSSI circuit provides dynamic range of typically 60dB.

The change of RSSI output voltage has a transient response against the change of IF input signal level. The curve of RSSI response is determined by the two factors:

1. Time constant:  $T = C_{EXT} \times R_{0\_RSSI}$
2. The difference of voltage:  $V_{RSSI}(T1) - V_{RSSI}(T2)$   
 where  $C_{EXT}$ : external capacitance connected at pin6  
 $R_{0\_RSSI}$ : RSSI Output Resistance (internal resistor)

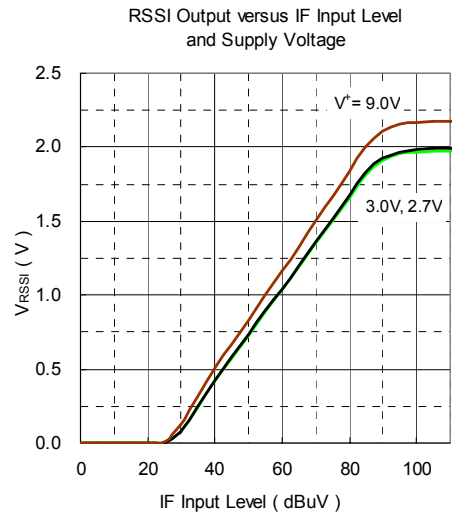

NJM2549 has an internal resistance of 15kohm at Pin6. When  $C_{EXT}=1nF$ , the calculated value of T (T1->T2) is 15usec. If another large external capacitance exists, this also influences to the RSSI response time.

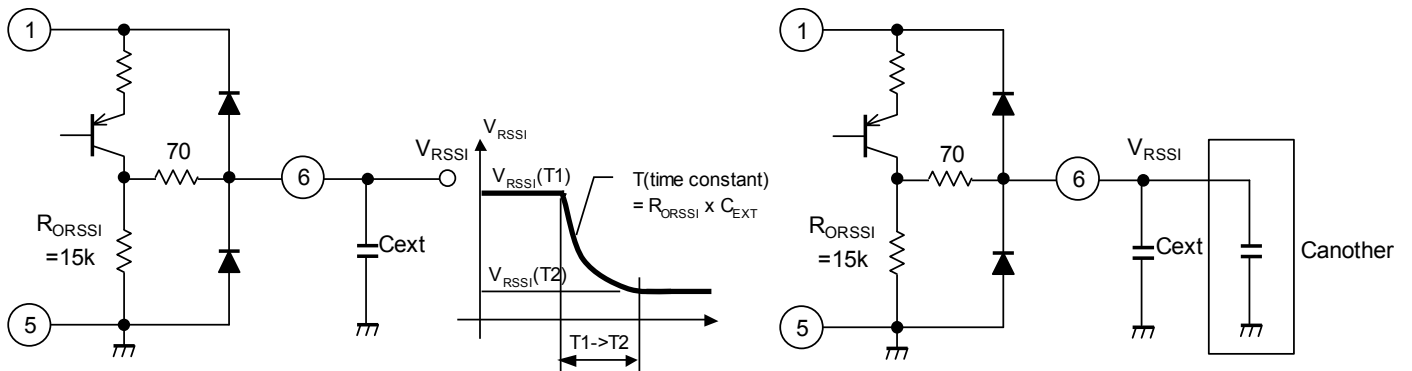

**How to Treat Unused Pin**

When the FM demodulator is not used, unused AF OUT pin (Pin10) is left open and unused QUAD IN pin (Pin9) is connected to power supply that is the same power supply voltage to V+ pin (Pin1). When the RSS is not used, unused RSSIOUT pin (Pin6) is left open. When the IF output is not used, it is recommended that unused IF OUT pins (Pin7 and 8) are left open.

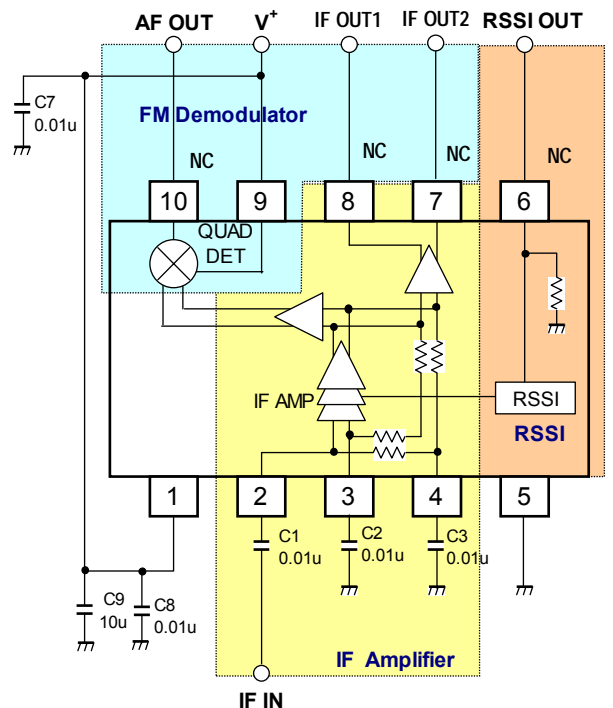

**Noise and Sensitivity**

This document specifies the following characteristics related to noise and sensitivity at low input signal level: S/N, -3dB limiting sensitivity, 12dB SINAD, and AMR. In general, the ways of improving these characteristics are:

- 1) To increase AF OUT output level of demodulated signal
- 2) To remove noise factor

The way to increase AF OUT output level is already mentioned. As an example of how to remove noise factor, adding LPF at AF OUT is effective, especially to remove the factor of IF carrier signal and its harmonics involved in demodulated signal. The following characteristics show the effect of an additional LPF.

An additional LPF is not connected:

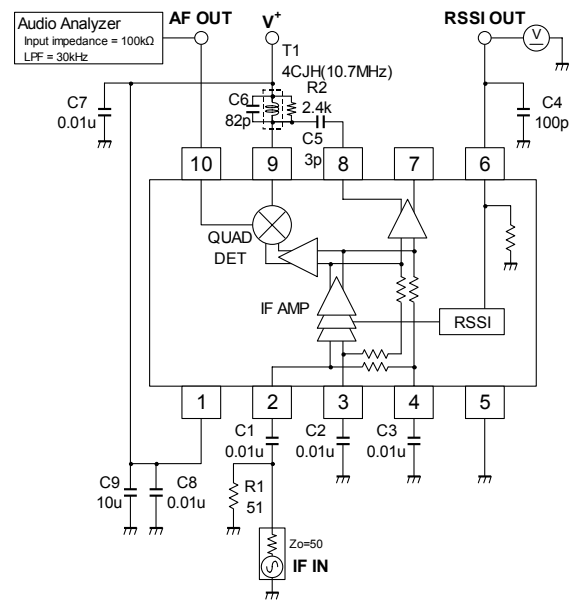
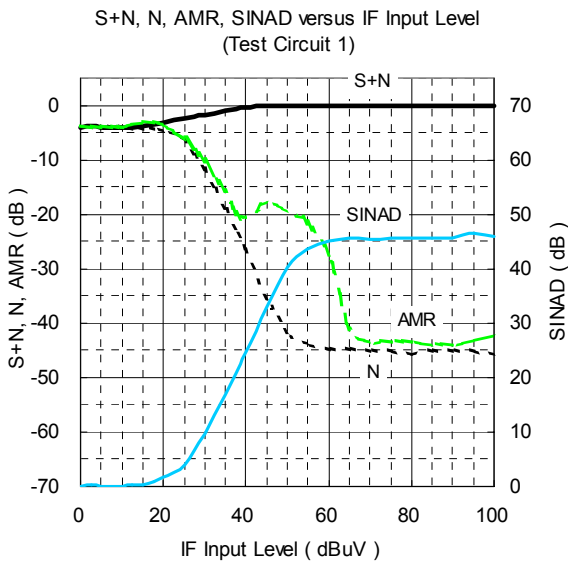

An additional LPF is connected:

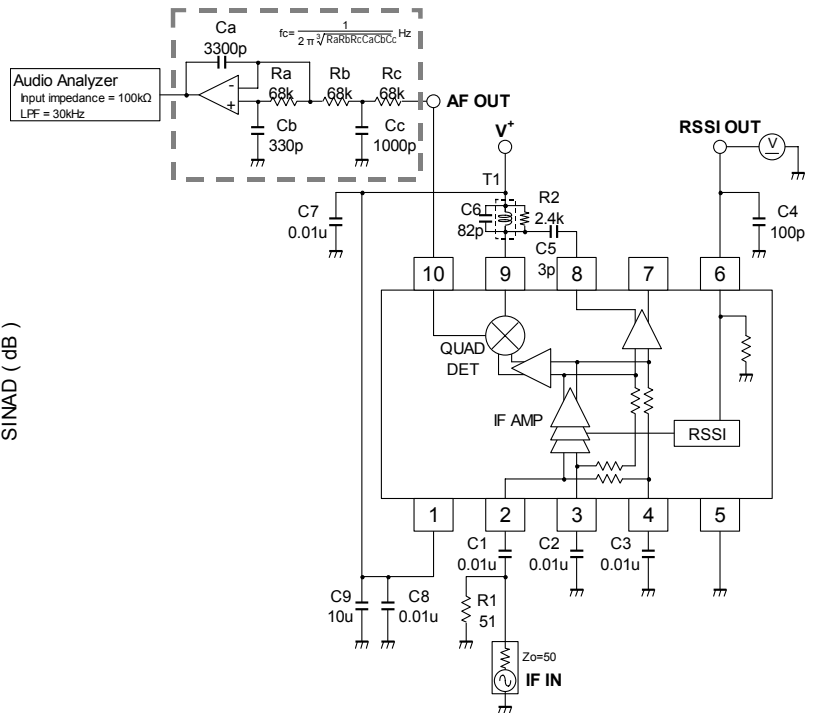
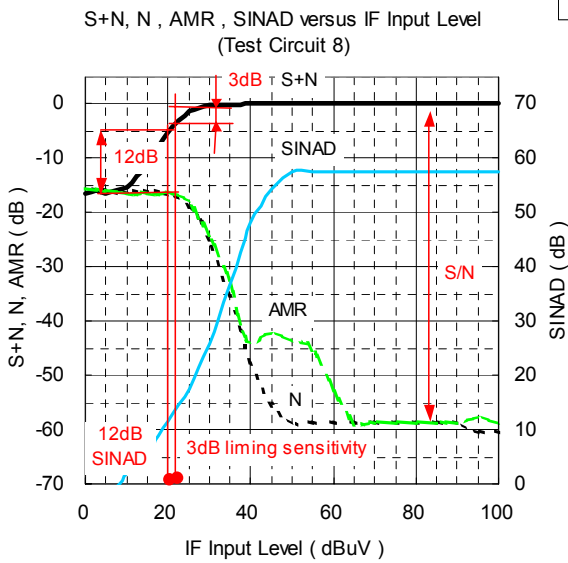

**■ PARAMETER DESCRIPTION**

PARAMETER	SYMBOL	DESCRIPTION
IF input signal	IF IN	Carrier frequency and input level of IF input signal.
IF signal deviation	fdev	FM deviation of IF input signal.
IF signal modulation	fmod	Frequency of base-band signal that FM modulates carrier to generate FM IF signal.
Current consumption	Iccq	Total current through V+(Pin1) and QUAD IN (Pin9) under no IF signal input..
IF input/Output Gain	G <sub>IF</sub>	Difference between unbalanced input signal level at IF IN (Pin2) and output signal level at IF OUT (Pin7).
IF output gain frequency characteristics	f <sub>IF</sub>	Difference of G <sub>IF</sub> at the two different IF frequency.
IF amplifier input impedance	R <sub>IF</sub>	Impedance between IF IN (Pin2) and IF DEC (Pin4).
IF output level	V <sub>OIF</sub>	Output voltage of demodulated signal at IF OUT (Pin 7,8)
Duty ratio of wave IF output	DR <sub>IF</sub>	Duty ratio of demodulated signal.
IF output current	I <sub>OIF</sub>	Current at IF OUT (Pin7 or 8) under no IF signal input.
Demodulated DC level	V <sub>ODC</sub>	DC output voltage at AF OUT (Pin10) under unmodulated IF carrier signal input.
Demodulated signal level	V <sub>OAC</sub>	Output voltage of demodulated signal at AF OUT (Pin10) under the standard condition.
Demodulated signal level of IF/3	V <sub>OAC2</sub>	Output voltage of demodulated signal at AF OUT (Pin10). IF carrier frequency is one third of the standard value.
12dB SINDA sensitivity	12dBS/N	IF input signal level at 12dB SINAD (Signal-to-noise and distortion ratio, (S+N+D) / (N+D))
-3dB limiting sensitivity	P <sub>LIM</sub>	IF input signal level. AF OUT voltage of demodulated signal (S+N+D) is 3dB lower than the value in the stable region.
Signal to noise ratio	S/N	S/N of demodulated signal.
AM rejection ratio	AMR	Ratio of AM demodulated signal level and FM demodulated signal level. The former is under AM IF input, and the latter is under FM IF input.
Total harmonic distortion	THD	Ratio of signal level between total harmonic factors involved in demodulated signal and base-band signal.
AF output bias current	I <sub>OAF</sub>	Current at AF OUT (Pin10) under no IF signal input.
Demodulated signal frequency characteristics	f <sub>DET</sub>	Flatness of demodulated signal level over a wide frequency range of base-band signal.
RSSI output voltage	V <sub>RSSI</sub>	RSSI output voltage at RSSI OUT (Pin6).
RSSI output resistance	R <sub>O_RSSI</sub>	Resistance between RSSI (Pin6) and GND (Pin5).
RSSI dynamic range	D <sub>RSSI</sub>	Range of IF input level while RSSI output voltage is proportional to the log of IF input signal level.
RSSI response	T <sub>RI</sub> /T <sub>FI</sub>	Rise time / fall time of RSSI output voltage.

**■ ABSOLUTE MAXIMUM RATINGS** (Ta=25°C)

PARAMETER	SYMBOL	RATINGS	UNIT
Supply Voltage	$V^+$	10	V
Power Dissipation	$P_D$	300	mW
Operating Temperature	$T_{opr}$	- 40 to + 85	°C
Storage Temperature	$T_{stg}$	- 50 to + 125	°C

**■ RECOMMENDED OPERATIONAL CONDITION** (Ta=25°C)

PARAMETER	SYMBOL	TEST CONDITIONS	MIN.	TYP.	MAX.	UNIT
Supply Voltage	$V^+$		2.7	3	9	V

**■ ELECTRICAL CHARACTERISTICS**

(Ta = 25°C,  $V^+ = 3V$ , IF IN = 10.7MHz / 80dBuV, fdev = ± 10kHz, fmod = 1kHz, unless otherwise noted)

PARAMETER	SYMBOL	TEST CONDITIONS	MIN.	TYP.	MAX.	UNIT
Current Consumption	$I_{ccq}$	No Signal, Test Circuit 1	-	3	3.7	mA
<b>IF</b>						
IF Input / Output Gain	$G_{IF}$	IF IN = 20dBuV , Test Circuit 4	70	75	80	dB
IF Output Gain Frequency Characteristics	$f_{IF1}$	The ratio from the gain at 10.7MHz to the gain at 1MHz, Test Circuit 4	-3	0	3	dB
	$f_{IF2}$	The ratio from the gain at 10.7MHz to the gain at 15MHz, Test Circuit 4	-4	-1	2	
IF Amplifier Input Resistance	$R_{iIF}$	2 - 4 pin Resistance, Test Circuit 3	8.5	10	11.5	kΩ
IF Output Level	$V_{OIF}$	RL = 15kΩ, No Modulation, Test Circuit 4	350	425	500	mVpp
Duty Ratio of Wave IF Output	$DR_{IF}$	RL = 15kΩ, No Modulation, Test Circuit 4	44	50	58	%
IF Output Current	$I_{OIF}$	No Signal, Test Circuit 4	230	290	350	uA

PARAMETER	SYMBOL	TEST CONDITIONS	MIN.	TYP.	MAX.	UNIT
<b>DETECTION</b>						
Demodulated DC Level	$V_{O_{DC1}}$	IF IN = 10.62MHz, No Modulation, Test Circuit 1	-	0.1	0.3	V
	$V_{O_{DC2}}$	IF IN = 10.7MHz, No Modulation, Test Circuit 1	0.8	1.1	1.4	
	$V_{O_{DC3}}$	IF IN = 10.83MHz, No Modulation, Test Circuit 1	2.7	2.9	-	
Demodulated Signal Level	$V_{O_{AC1}}$	Test Circuit 1	120	150	180	mVrms
Demodulated Signal Level of IF/3	$V_{O_{AC2}}$	IF IN = 3.56667MHz, 100dBuV, Test Circuit 1	100	130	160	
12dB SINAD Sensitivity	12dBS/N	Test Circuit 1	-	33	-	dBuV
- 3dB Limiting Sensitivity	$P_{LIM}$	Measured at -3dB, Test Circuit 1	-	22	-	
Signal to Noise Ratio	S/N	Ratio of S+N and N, Test Circuit 1	-	45	-	dB
AM Rejection Ratio	AMR	AM = 30%, Test Circuit 1	-	45	-	
Total Harmonic Distortion	THD	fdev = ± 30kHz, Test Circuit 1	-	0.5	-	%
AF Output pin Bias Current	$I_{OAF}$	No Signal, Test Circuit 4	160	205	250	uA
Demodulated Signal Frequency Characteristics	$f_{DET}$	fdev = ±100kHz, fmod = 1kHz to 1MHz, Gain deflection, Test Circuit 6	-	-2	-	dB
<b>RSSI</b>						
RSSI Output Voltage	$V_{RSSI1}$	No Signal, Test Circuit 1	-	10	50	mV
	$V_{RSSI2}$	IF IN = 45dBuV, Test Circuit 1	350	550	750	
	$V_{RSSI3}$	IF IN = 80dBuV, Test Circuit 1	1.5	1.7	1.85	V
	$V_{RSSI4}$	IF IN = 100dBuV, Test Circuit 1	1.8	2	2.1	
RSSI Output Resistance	$R_{O_{RSSI}}$	5 - 6 pin Resistance, Test Circuit 3	12	15	18	KΩ
RSSI Dynamic Range	$D_{RSSI}$	$X = (V_{RSSI3} - V_{RSSI2}) / 35$ , $D1 = 45 - (V_{RSSI2} - V_{RSSI1}) / X$ , $D2 = 80 + (V_{RSSI4} - V_{RSSI3}) / X$ , $D_{RSSI} = D2 - D1$	-	60	-	dB
RSSI Response	$T_{RI}$	Time taken for RSSI Output to change from 10% to 90% after IF signal turns on. Test Circuit 7	-	4	-	usec
	$T_{FI}$	Time taken for RSSI Output to change from 90% to 10% after IF signal turns off. Test Circuit 7	-	4	-	

The values shown in parenthesis are reference values.

■ TEST CIRCUIT

This test circuit allows the measurement of all parameters described in "ELECTRICAL CHARACTERISTICS".

● Test Circuit 1 (Detected Output: S-Curve)

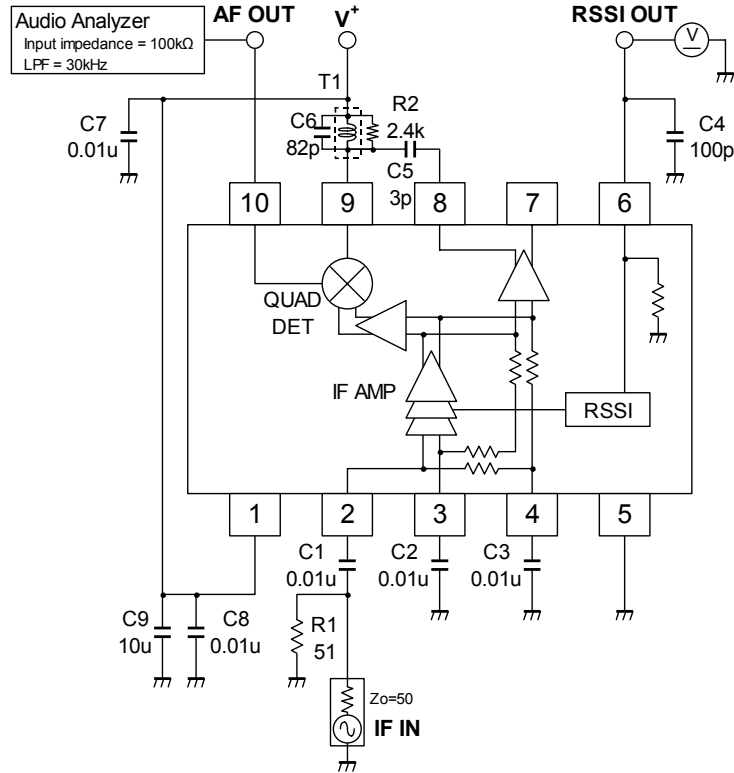

● Test Circuit 2 (Detected Output: N-Curve, the Detected Output is reversed)

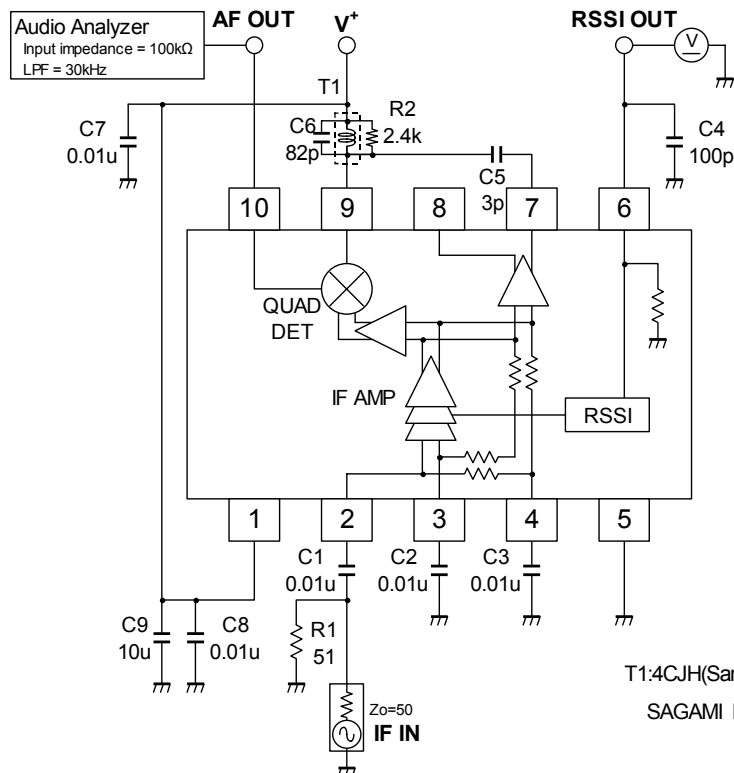

T1:4CJH(Sample No.:080293006)  
SAGAMI ELEC CO., LTD. (Japan)

● Test Circuit 3 for Terminal Resistance

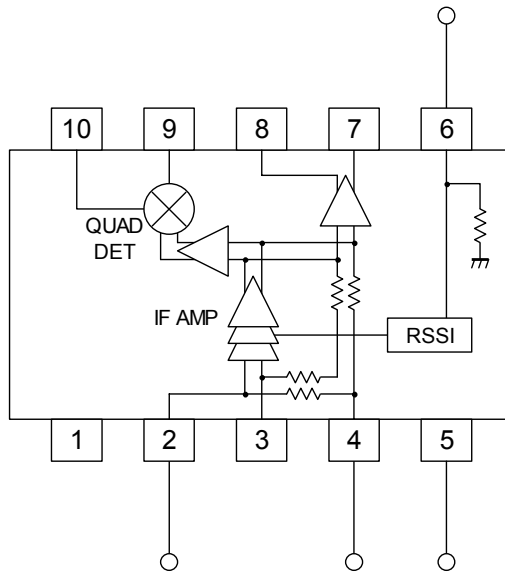

● Test Circuit 4 for IF Amplifier

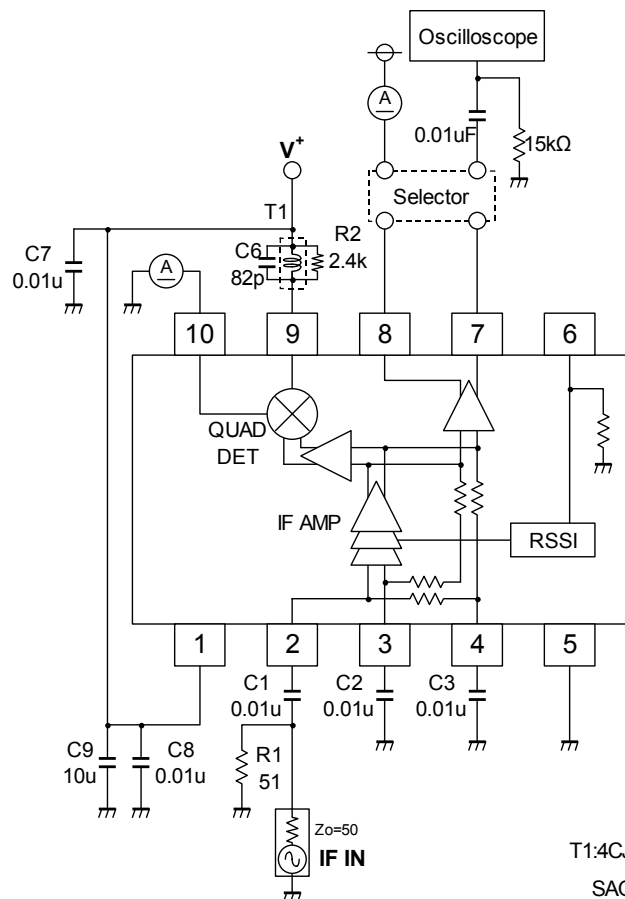

T1:4CJH(Sample No.:080293006)  
SAGAMI ELEC CO., LTD. (Japan)

● Test Circuit 5 for Demodulated Signal Frequency Characteristics (Detected Output: S-Curve)

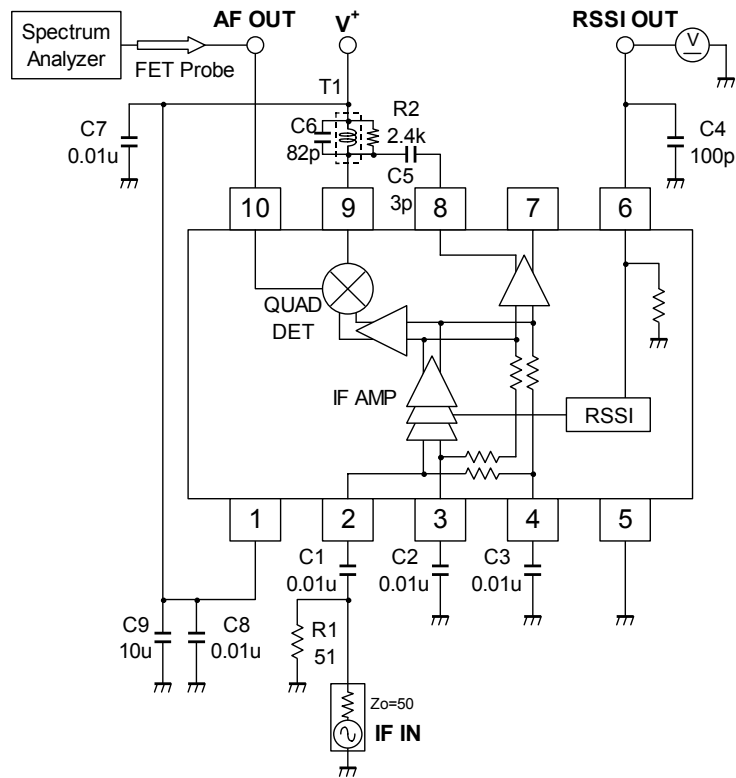

● Test Circuit 6 for Demodulated Signal Frequency Characteristics (Detected Output: N-Curve)

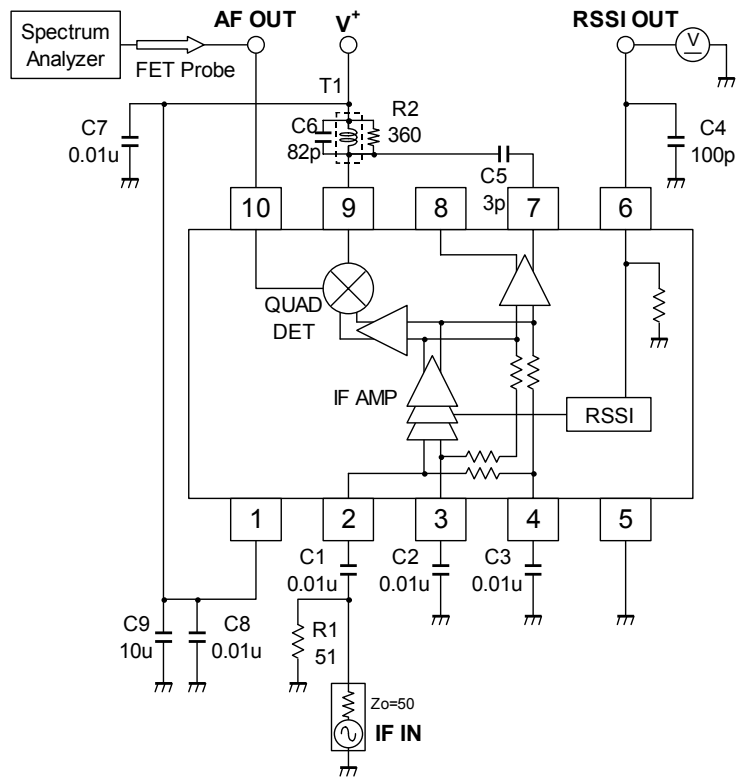

T1:4CJH(Sample No.:080293006)  
SAGAMI ELEC CO., LTD. (Japan)



● Test Circuit 7 for RSSI Response

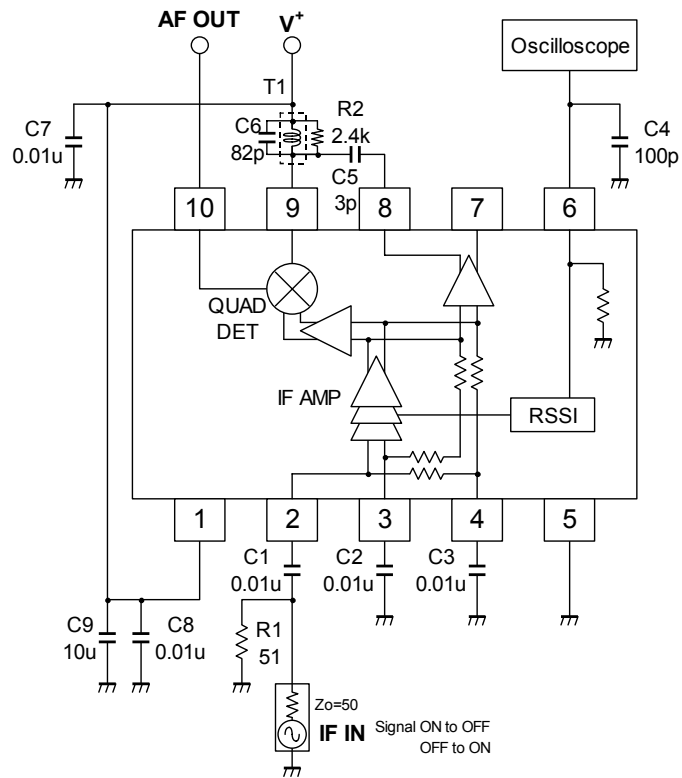

● Test Circuit 8 for Demodulated signal (LPF is connected)

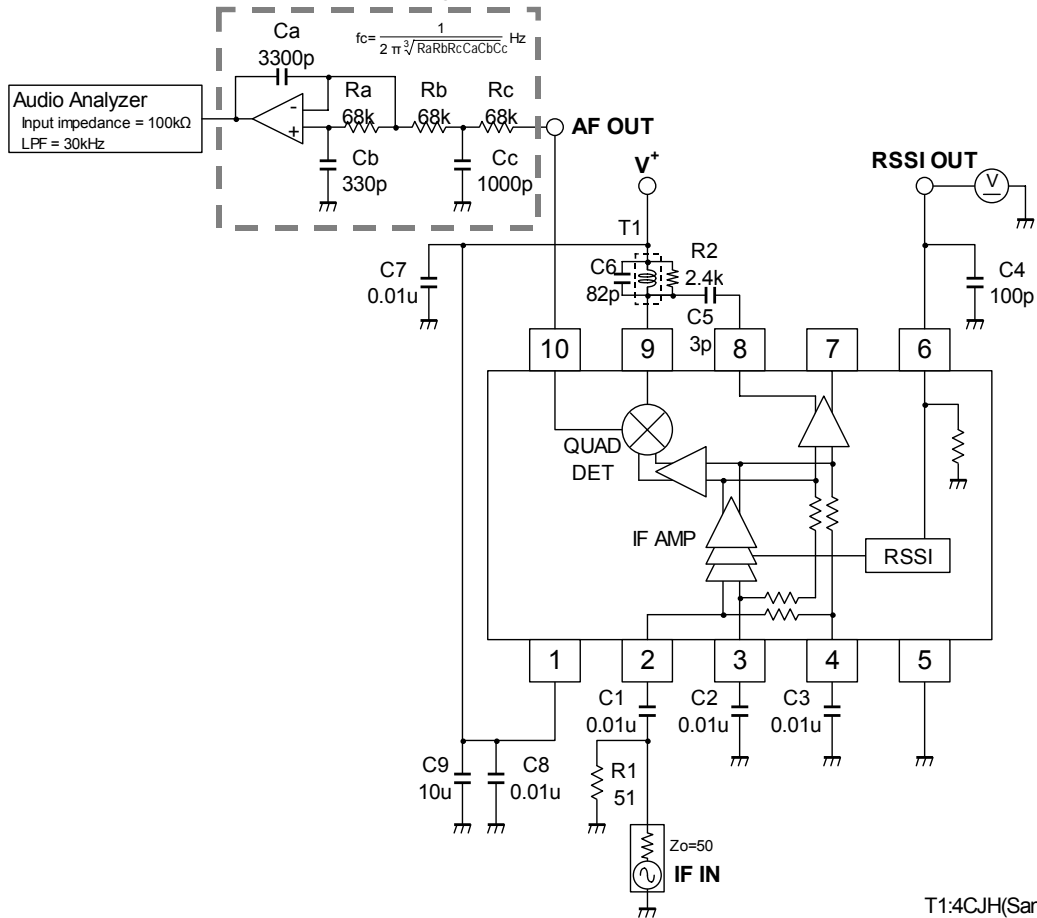

T1:4CJH(Sample No.:080293006)

SAGAMI ELEC CO., LTD. (Japan)

■ TERMINAL FUNCTION

(Ta = 25°C, V<sup>+</sup> = 3V, No signal)

Pin No.	SYMBOL	EQUIVALENT CIRCUIT	VOLTAGE	FUNCTION
1	V <sup>+</sup>		--	Supply Voltage
2 3 4	IF IN IF DEC1 IF DEC2		1.95V	<b>2pin: IF Amplifier Input</b> <b>3,4pin: IF Decoupling</b> An external decoupling capacitor is connected to enhance stability. The bandwidth of IF Amplifier can be adjusted. Large capacity: narrow IF Small capacity: wide IF
6	RSSI		--	<b>Received Signal Strength Indicator Output</b> Pin6 outputs DC level proportional to the log of pin2 input signal level.
7 8	IF OUT2 IF OUT1		1.25V	<b>FM IF Output</b> This is a balanced output, and the capacitor for the phase-shifter is connected between QUAD IN and either of IF OUTs. The joining terminal changes the inclination. 7pin:N-Corve 8pin:S-Corve

Pin No.	SYMBOL	EQUIVARENT CIRCUIT	VOLTAGE	FUNCTION
9	QUAD IN		--	<p><b>Quadrature Detector Input</b>            An external phase-shifting coil or discriminator is connected between IF OUT and pin9.            Note that supply voltage should be the same as the voltage supplied to pin1.</p>
10	AF OUT		1.05V	<p><b>Demodulated Signal Output</b>            Can output the wide range between ground level and supply voltage level.</p>

■ EVALUATION BOARD

The evaluation board is useful for your design and to have more understanding of the usage and performance of this device. This circuit is the same as TEST CIRCUIT. Note that this board is not prepared to show the recommendation of pattern and parts layout.

● Circuit Diagram

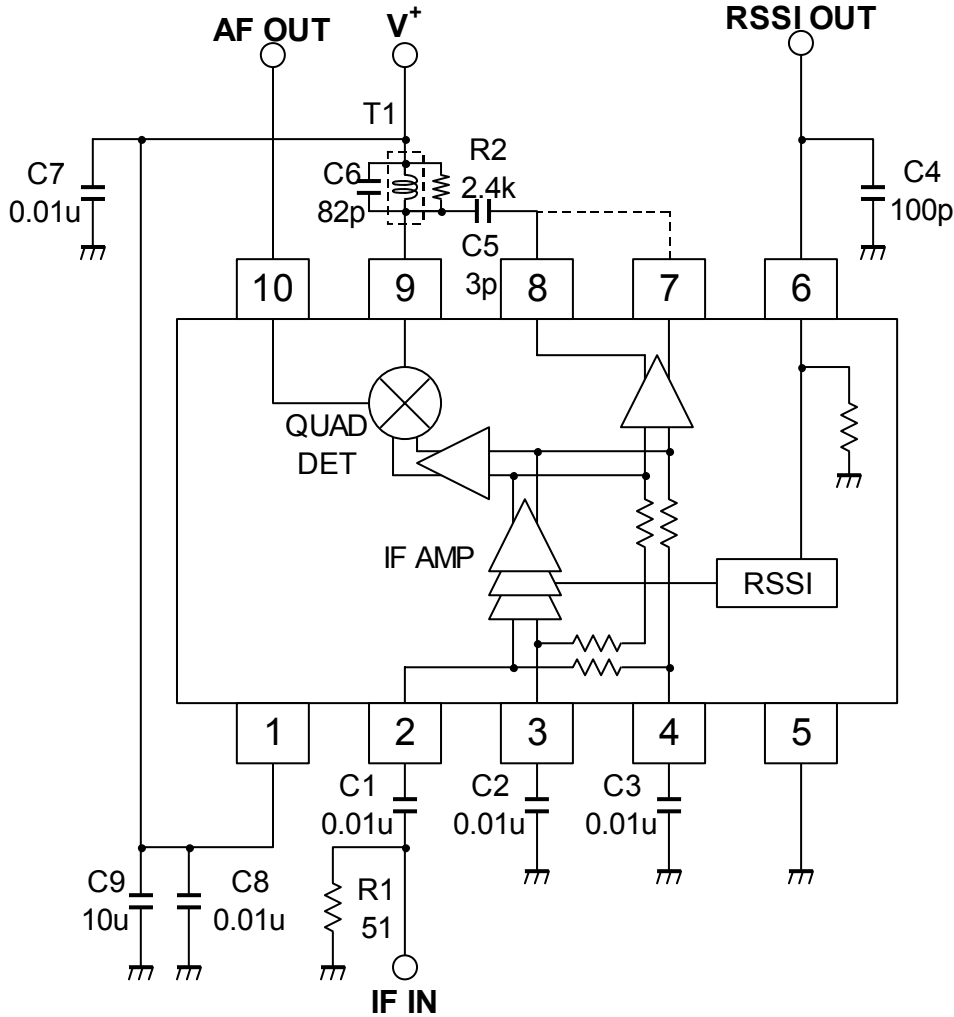

● List of Component

Items	Designation	Value	Items	Designation	Value
Capacitor	C1	0.01uF	Resistor	R1	51Ω
Capacitor	C2	0.01uF	Resistor	R2	2.4kΩ
Capacitor	C3	0.01uF			
Capacitor	C4	100pF	Transformer	T1	4CJH
Capacitor	C5	3pF			
Capacitor	C6	82pF	IC	IC1	NJM2549
Capacitor	C7	0.01uF			
Capacitor	C8	0.01uF			
Capacitor	C9	10uF			

Note: The IF transformer (T1) is prepared just for the use of NJM2549 evaluation board.

Model: 4CJH(Sample No.:080293006), Supplier: SAGAMI ELEC CO., LTD. (Japan)

● PRINTED CIRCUIT BOARD

Circuit Side View

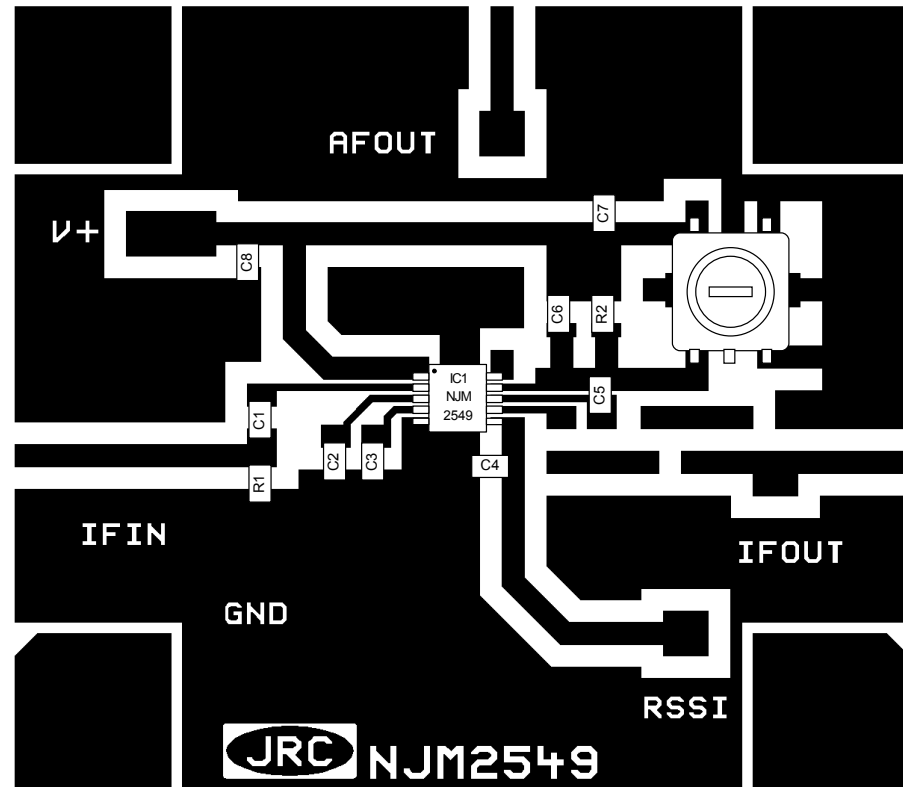

Ground Side View

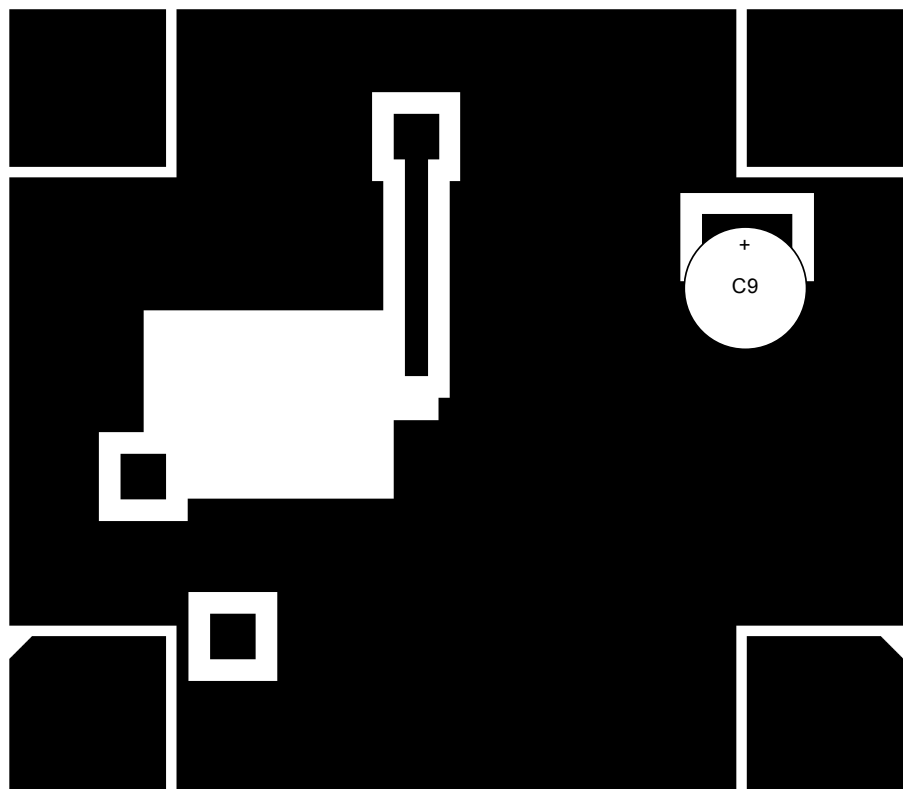

■ TYPICAL CHARACTERISTICS

[DC CHARACTERISTICS]

(Test Circuit 1,  $T_a = 25^\circ\text{C}$ ,  $V^+ = 3\text{V}$ , No Signal, unless otherwise noted)

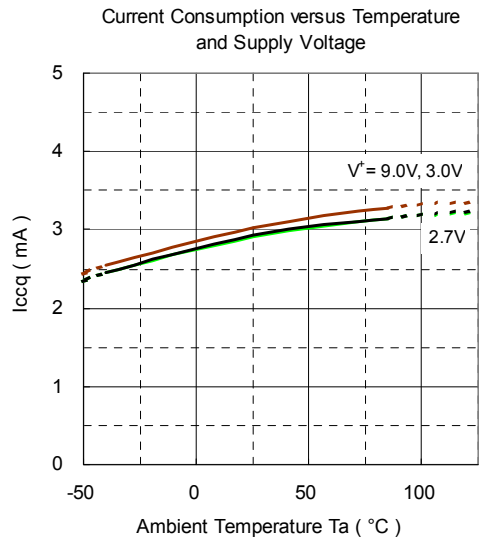
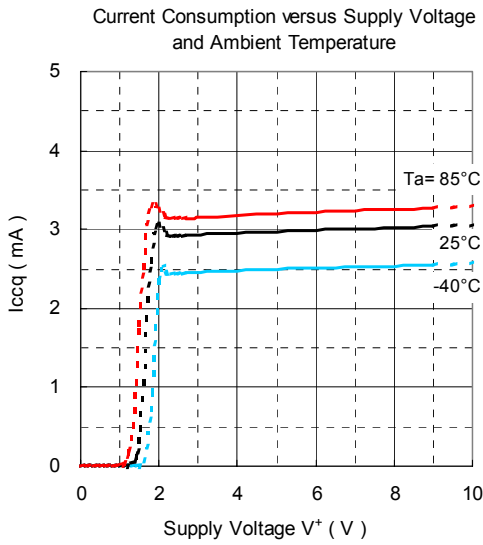

[IF AMP CHARACTERISTICS]

(Test Circuit 4,  $T_a = 25^\circ\text{C}$ ,  $V^+ = 3\text{V}$ , IF IN = 10.7MHz / 20dBuV, No Modulation, unless otherwise noted)

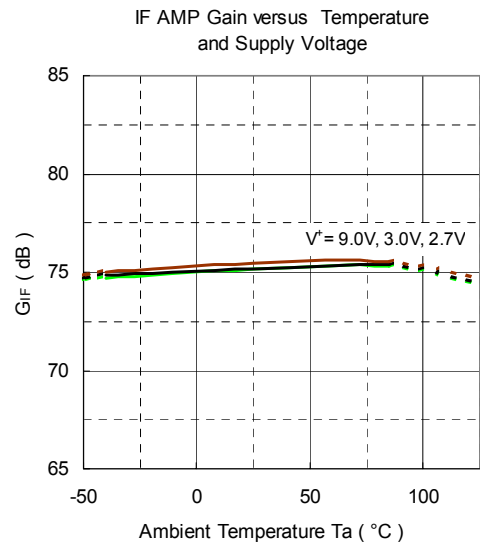
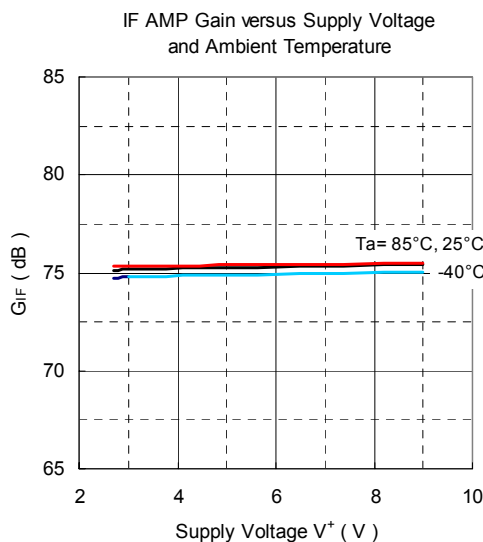
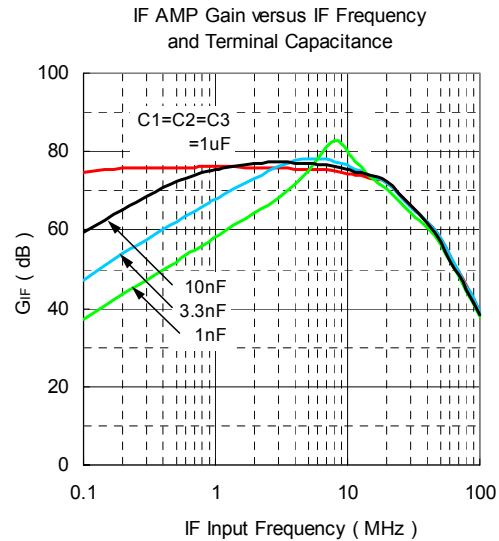
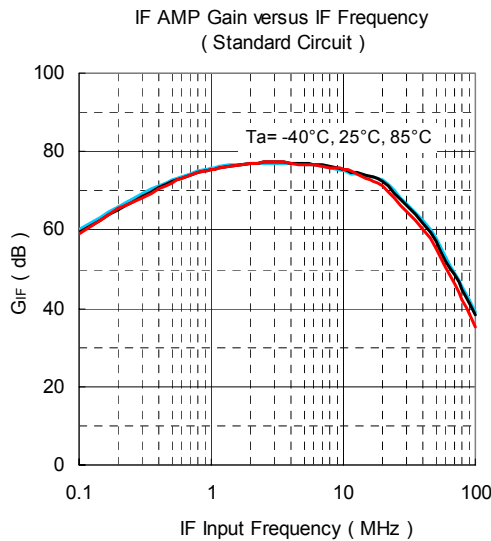

IF Output Level versus Supply Voltage and Ambient Temperature

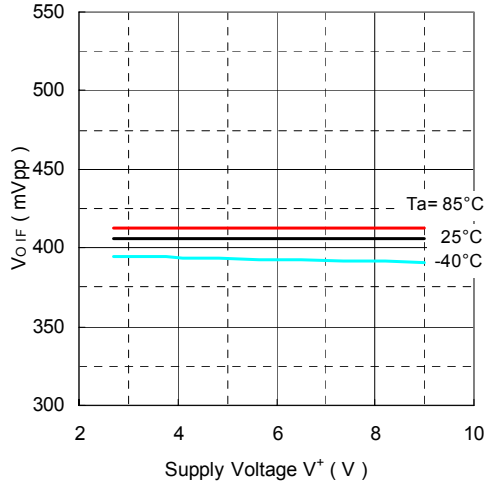

IF Output Level versus Temperature and Supply Voltage

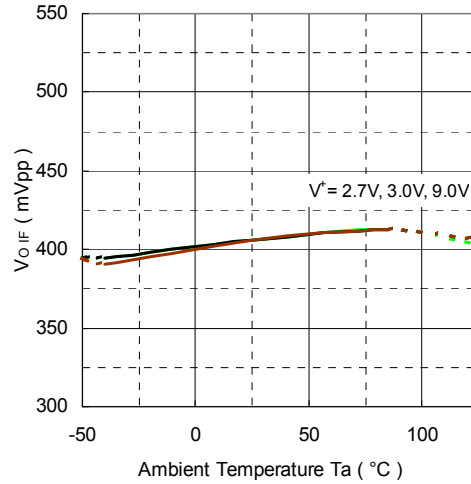

IF Output Duty Ratio versus Supply Voltage and Ambient Temperature

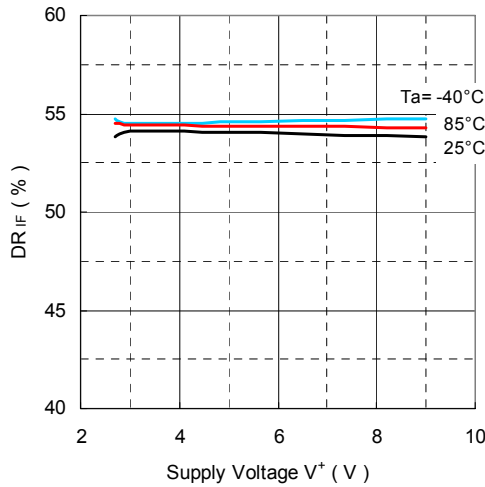

IF Output Duty Ratio versus Temperature and Supply Voltage

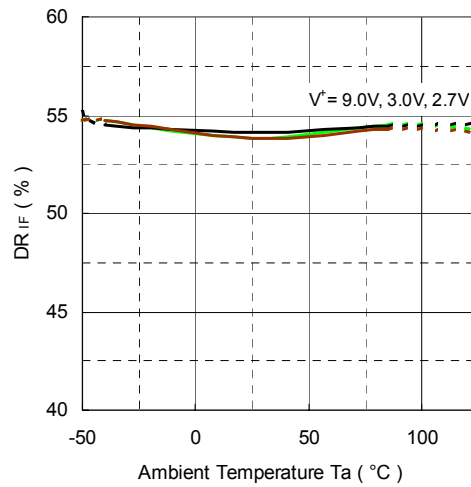

IF Output Current versus Supply Voltage and Ambient Temperature

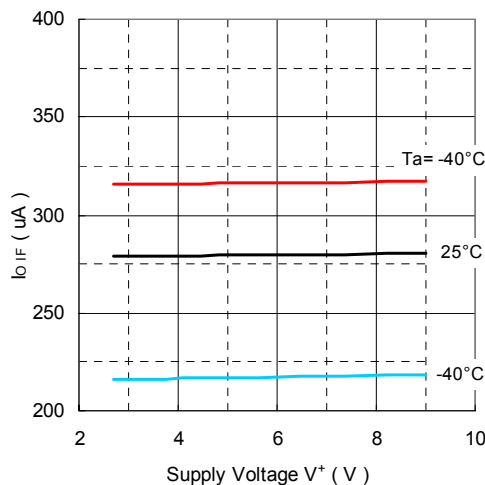

IF Output Current versus Temperature and Supply Voltage

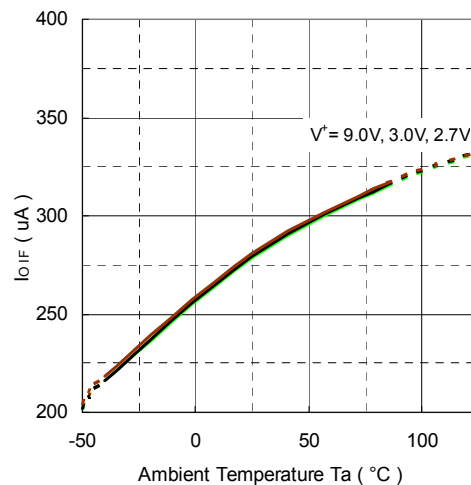

**[DEMODULATED CHARACTERISTICS (S-Curve)]**

(Test Circuit 1,  $T_a = 25^\circ\text{C}$ ,  $V^+ = 3\text{V}$ , IF IN = 10.7MHz / 20dBuV, No Modulation, unless otherwise noted)

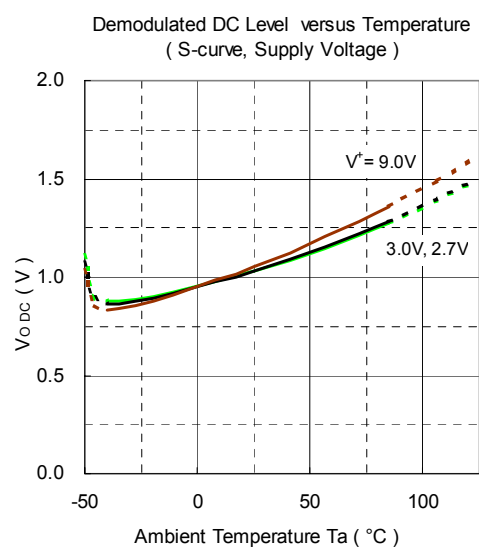
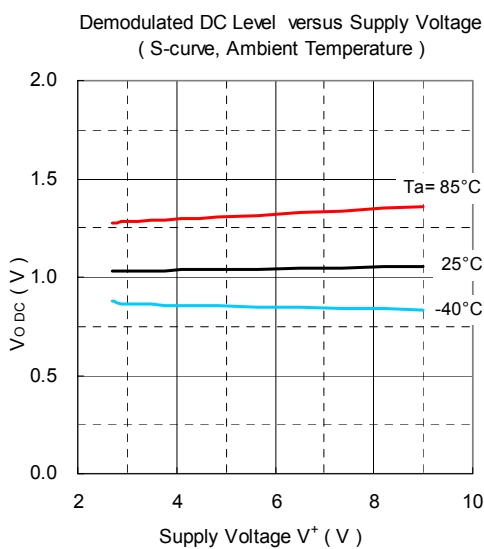
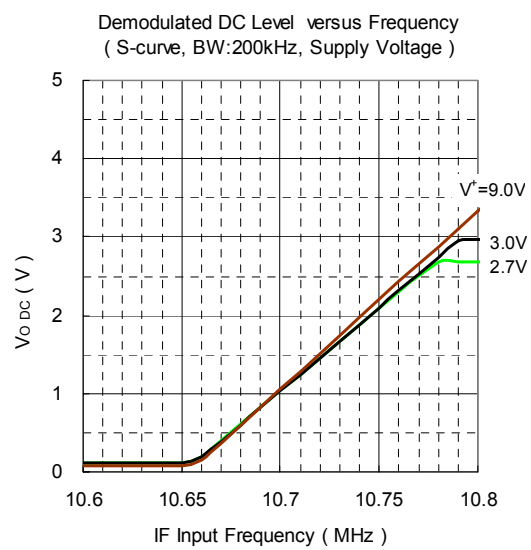
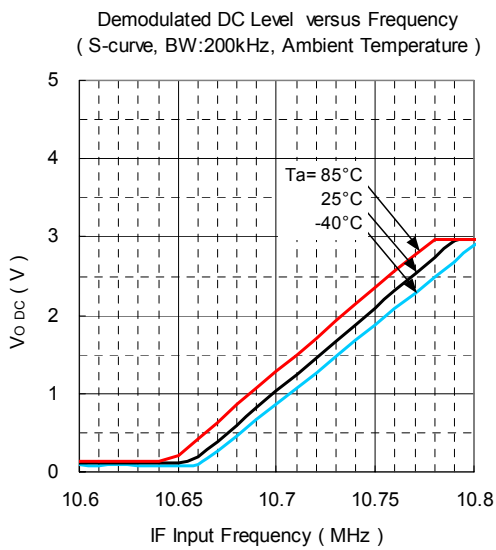
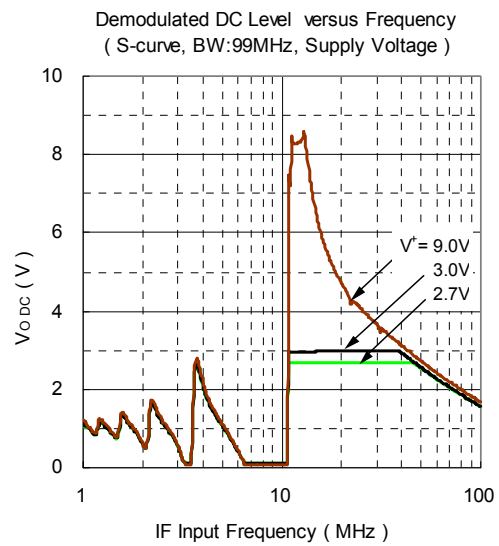
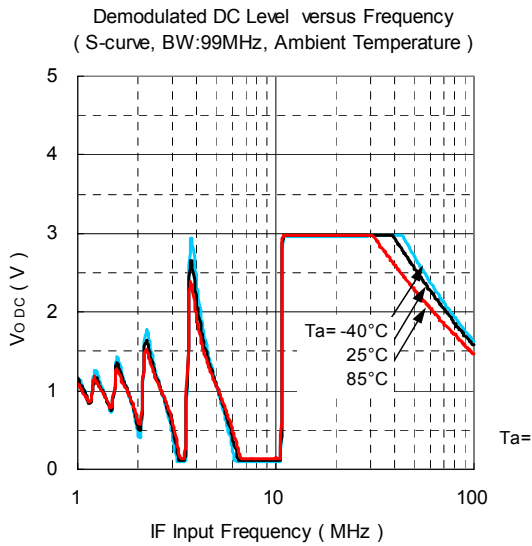



**[DEMODULATED CHARACTERISTICS (N-Curve)]**

(Test Circuit 2,  $T_a = 25^\circ\text{C}$ ,  $V^+ = 3\text{V}$ , IF IN = 10.7MHz / 20dBuV, No Modulation, unless otherwise noted)

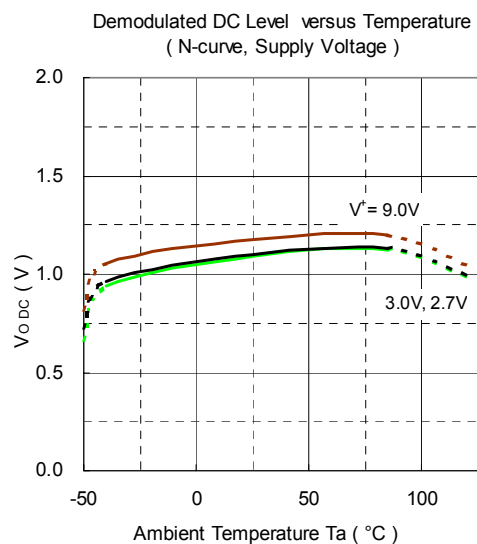
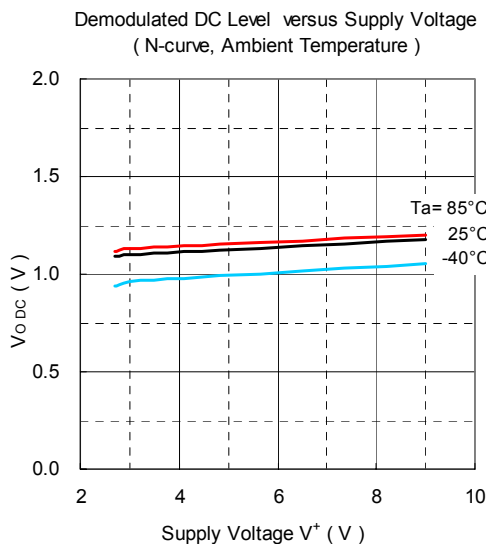
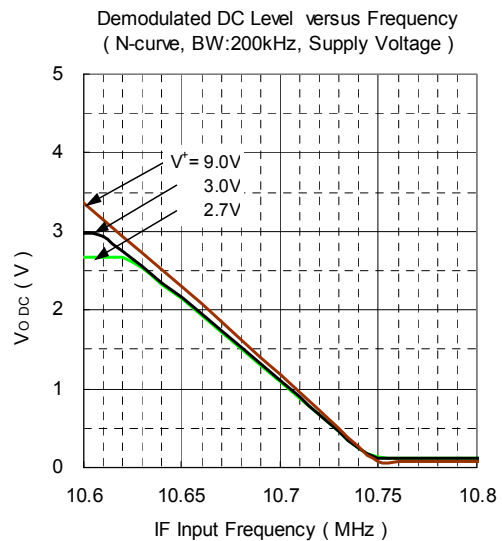
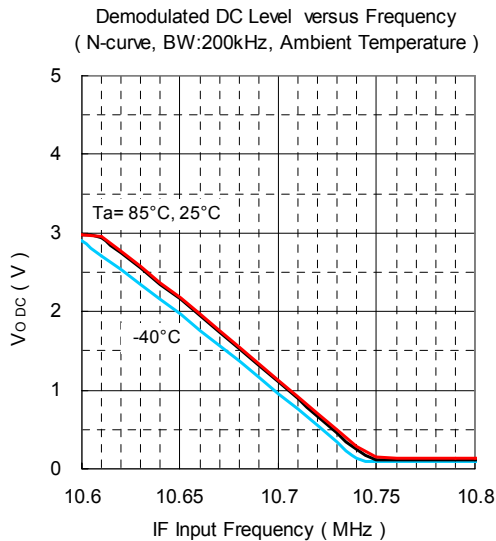
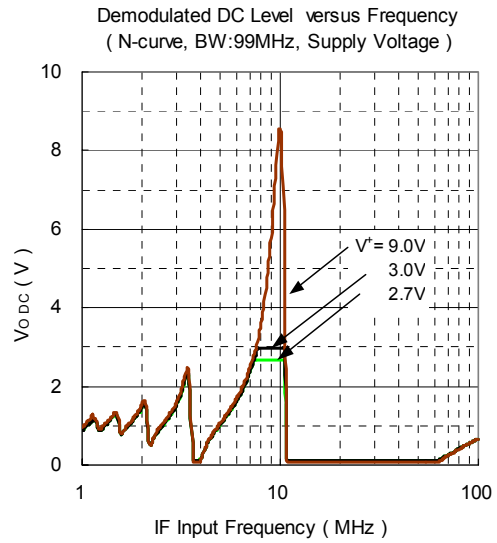
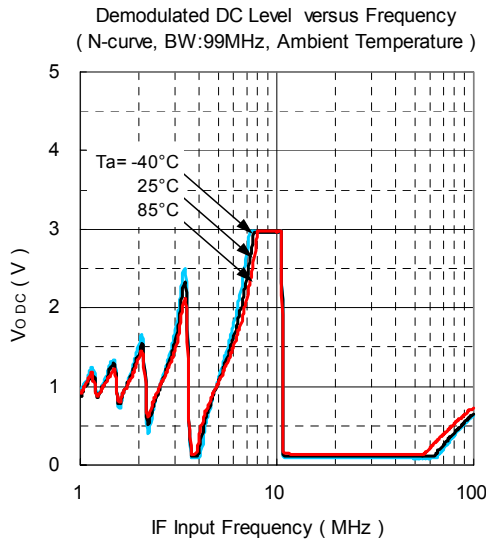

**[DEMODULATED CHARACTERISTICS (AC Level)]**

(Test Circuit 1, Ta = 25°C, V<sup>+</sup> = 3V, IF IN = 10.7MHz / 80dBuV, fdev = ± 10kHz, fmod = 1kHz, unless otherwise noted)

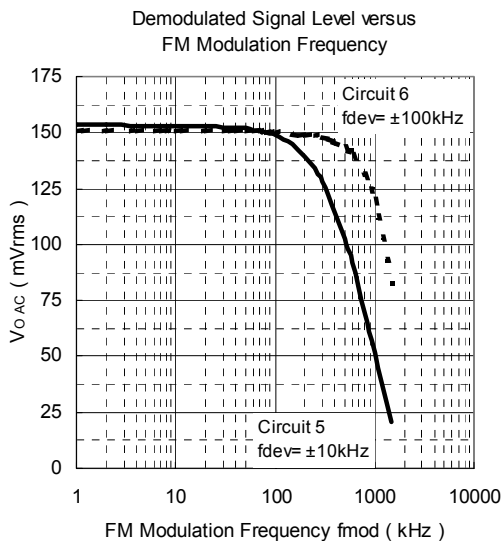
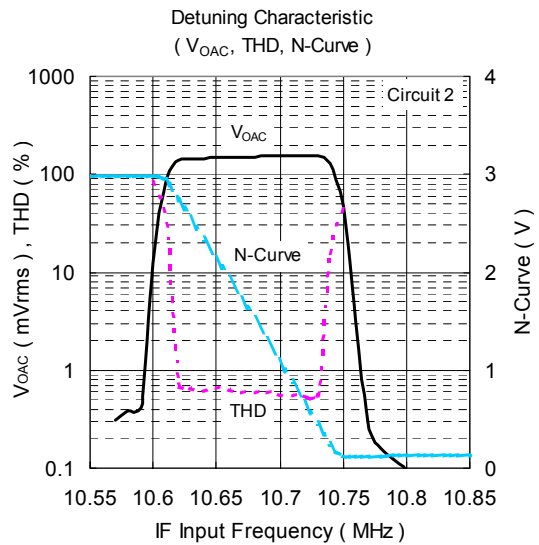
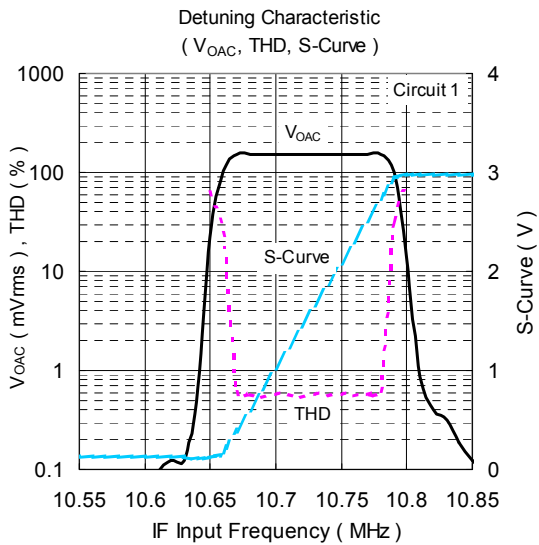
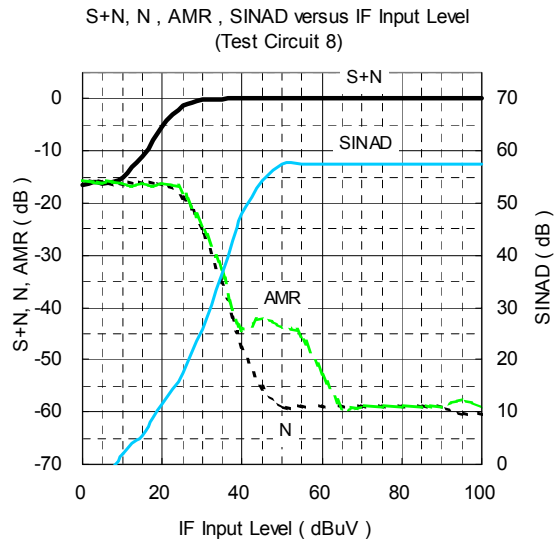
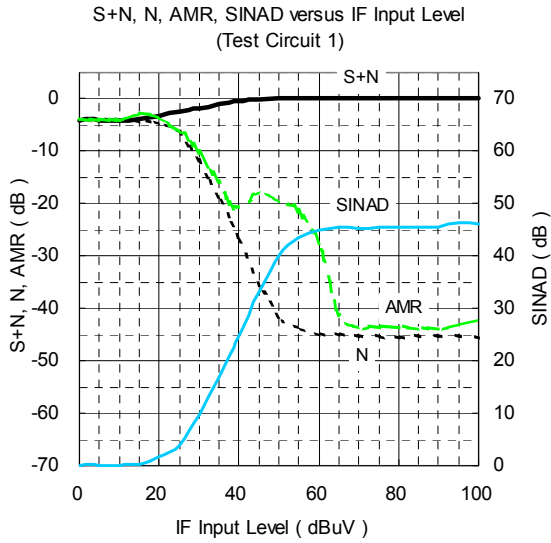

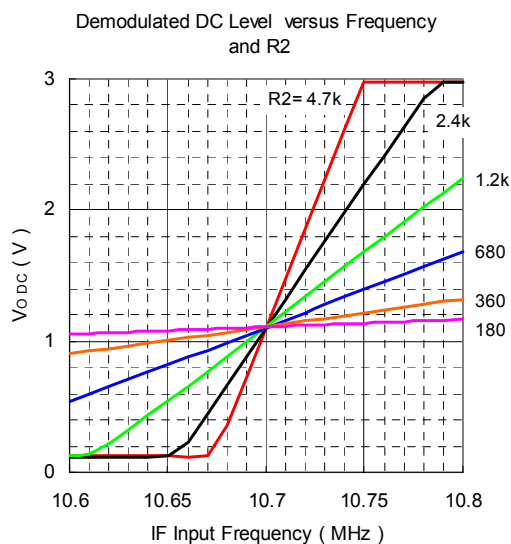
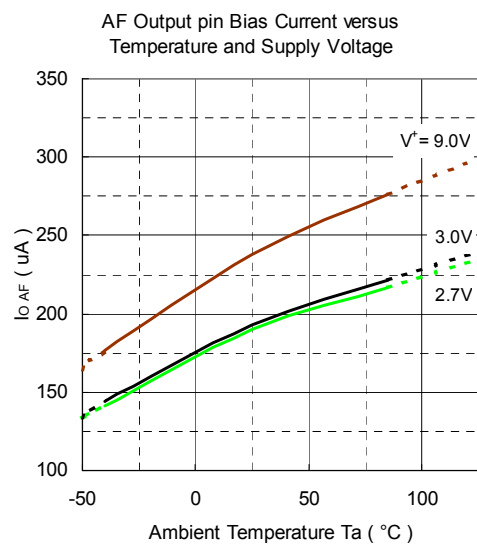
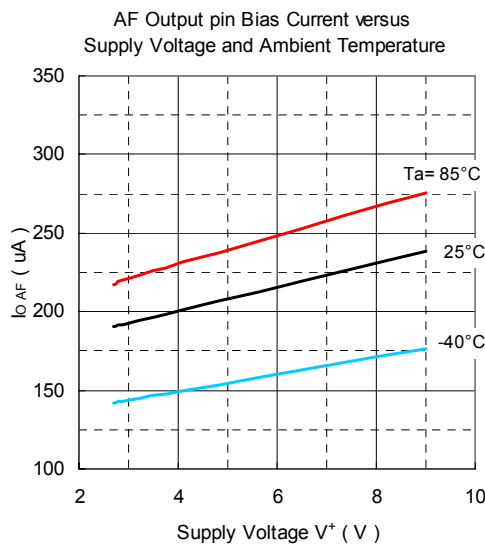
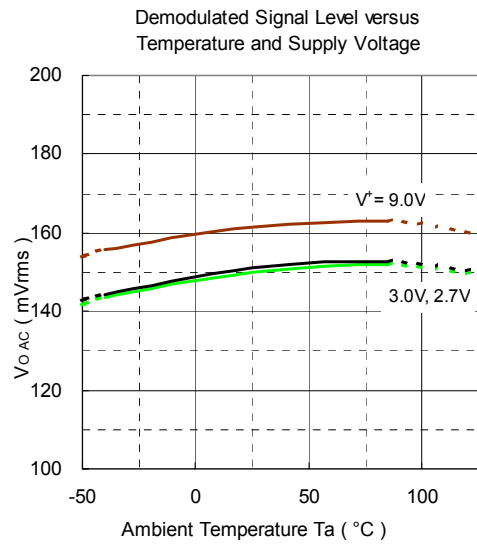
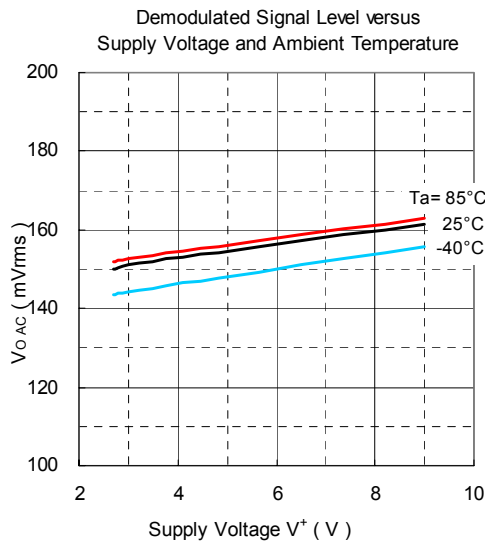

**[RSSI CHARACTERISTICS]**

(Test Circuit 1,  $T_a = 25^\circ\text{C}$ ,  $V^+ = 3\text{V}$ , IF IN = 10.7MHz / 80dBuV,  $f_{\text{dev}} = \pm 10\text{kHz}$ ,  $f_{\text{mod}} = 1\text{kHz}$ , unless otherwise noted)

RSSI Output versus IF Input Level and Ambient Temperature

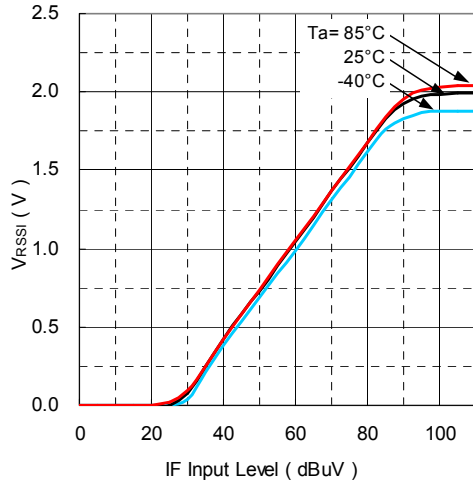

RSSI Output versus IF Input Level and Supply Voltage

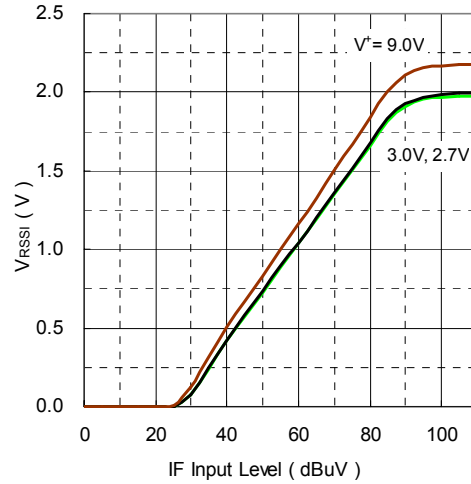

RSSI Output versus Supply Voltage and IF Input Level

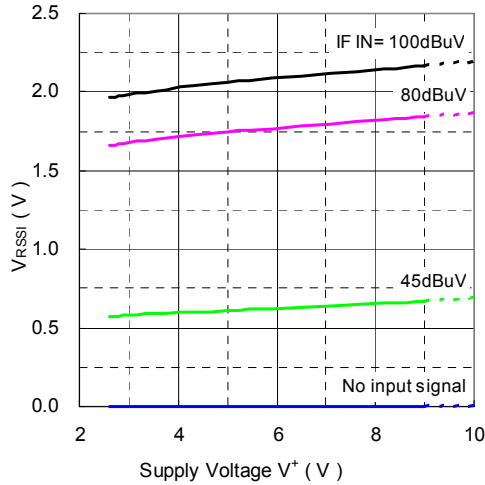

RSSI Output versus Temperature and IF Input Level

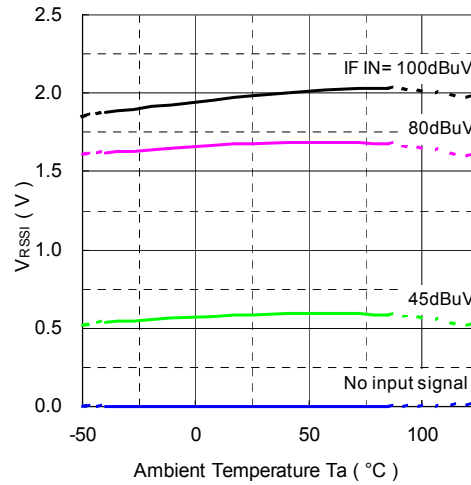

RSSI Output versus Supply Voltage Frequency and IF Input Level

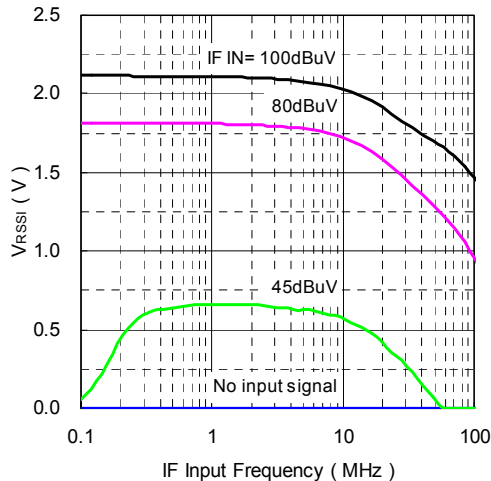

**[CAUTION]**  
The specifications on this databook are only given for information, without any guarantee as regards either mistakes or omissions. The application circuits in this databook are described only to show representative usages of the product and not intended for the guarantee or permission of any right including the industrial rights.

# Mouser Electronics

Authorized Distributor

Click to View Pricing, Inventory, Delivery & Lifecycle Information:

[NJR:](#)

[NJM2549RB2-TE2](#)



Компания «ЭлектроПласт» предлагает заключение долгосрочных отношений при поставках импортных электронных компонентов на взаимовыгодных условиях!

Наши преимущества:

- Оперативные поставки широкого спектра электронных компонентов отечественного и импортного производства напрямую от производителей и с крупнейших мировых складов;
- Поставка более 17-ти миллионов наименований электронных компонентов;
- Поставка сложных, дефицитных, либо снятых с производства позиций;
- Оперативные сроки поставки под заказ (от 5 рабочих дней);
- Экспресс доставка в любую точку России;
- Техническая поддержка проекта, помощь в подборе аналогов, поставка прототипов;
- Система менеджмента качества сертифицирована по Международному стандарту ISO 9001;
- Лицензия ФСБ на осуществление работ с использованием сведений, составляющих государственную тайну;
- Поставка специализированных компонентов (Xilinx, Altera, Analog Devices, Intersil, Interpoint, Microsemi, Aeroflex, Peregrine, Syfer, Eurofarad, Texas Instrument, Miteq, Cobham, E2V, MA-COM, Hittite, Mini-Circuits, General Dynamics и др.);

Помимо этого, одним из направлений компании «ЭлектроПласт» является направление «Источники питания». Мы предлагаем Вам помощь Конструкторского отдела:

- Подбор оптимального решения, техническое обоснование при выборе компонента;
- Подбор аналогов;
- Консультации по применению компонента;
- Поставка образцов и прототипов;
- Техническая поддержка проекта;
- Защита от снятия компонента с производства.



#### Как с нами связаться

**Телефон:** 8 (812) 309 58 32 (многоканальный)

**Факс:** 8 (812) 320-02-42

**Электронная почта:** [org@eplast1.ru](mailto:org@eplast1.ru)

**Адрес:** 198099, г. Санкт-Петербург, ул. Калинина, дом 2, корпус 4, литера А.