

# SPECIFICATION

OF

## LIQUID CRYSTAL DISPLAY MODULE



CUSTOMER : URT-STD

Model No. : UMSH-8253MD-1T

Model version : 0

Document Revision : 0

CUSTOMER APPROVED SIGNATURE			

This specification need to be signed by purchaser or customer as a specification of products production and delivery from URT. Without signature of this specification , any purchase order for this model no. will be treated and considered that this specification is automatically acknowledged and accepted by purchaser or customer.

 **U.R.T.**  **UNITED RADIANT TECHNOLOGY CORPORATION**

Allen Wang  
APPROVED

George Tseng  
CHECKED

Angus Chiu  
CHECKED

Sharon Tsai  
PREPARED

Jan-22-2009  
Date

COMPANY : No. 2,Fu-hsing Road,Taichung Economic Processing Zone,Tantzu,Taichung,Taiwan,R.O.C.

TEL: 886-4-25314277

FAX: 886-4-25313067



Revision 0 ; UMSH-8253MD-1T Ver. 0 ; January-22-2009

Page: 1

This document has been signed by Digital Signature Approval System



## UNITED RADIANT TECHNOLOGY CORP .

Headquarter office: NO.2 FU-SHING ROAD, T.E.P.Z. TANTZU, TAICHUNG, TAIWAN, R.O.C.  
TEL: +886-4-25314277 FAX: +886-4-25313067  
Factory: NO.12 CHIEN KUO ROAD, T.E.P.Z., TANTZU, TAICHUNG, TAIWAN, R.O.C.

To Whom It May Concern:

In continuing to develop and promote the strategic partnership between United Radiant Technology (URT) and Microtips USA (MTUSA), URT is please to announce that we have entered into an agreement with MTUSA to support some key projects only through MTUSA and as such the attached spec with URT Part no. will be manufactured by URT but support and logistic of the sales will be handled by MTUSA.

URT is confident that this arrangement between our two companies will ultimately benefit the end customer.

Thank You.

Raymond Chen

A handwritten signature in cursive script that reads "Raymond Chen". The signature is written in black ink and is positioned above a horizontal line.

Sales Manager: URT

## Revision record

Document Revision	Model No. Version No.	Description	Revision by
0	UMSH-8253MD-T (UFSH-K093EY-FT) Version No. 0	4.3" TFT.	Ring Hsu Zi Xin Ou 23-Jan-2009
1	UMSH-8253MD-1T (UFSH-K093EY-FT) Version No. 0	Remove the touch panel.	Ring Hsu Zi Xin Ou 22-Jan-2009

 <b>U.R.T.</b>	Revision 1 ; UMSH-8253MD-1T Ver. 0 ; January-22-2009	<b>Page: 2</b>
--	--	----------------

## CONTENTS:

No.	Item	Page
1	<b>BASIC SPECIFICATION</b>	
	1.1 Mechanical Specification	4
	1.2 Display Specification	4
	1.3 Outline Dimension	5
	1.4 Block Diagram	6
2	1.5 Interface Pin	7
	<b>ELECTRICAL CHARACTERISTICS</b>	
	2.1 Absolute Maximum Ratings	8
	2.2 DC Characteristics	9
3	2.2.1 Back-light Characteristics	9
	2.3 AC Characteristics	10~12
3	<b>OPTICAL CHARACTERISTICS</b>	
	3.1 Condition	13
4	3.2 Definition of Optical Characteristics	14~15
	<b>RELIABILITY</b>	16
5	<b>PRODUCT HANDING AND APPLICATION</b>	17
6	<b>DATECODE</b>	18
7	<b>PACKING &amp; LOTNO</b>	19~20
8	<b>INSPECTION STANDARD</b>	21~24

## 1. BASIC SPECIFICATION

### 1.1 Mechanical specifications

Items	Nominal Dimension	Unit
Active screen size	4.3" diagonal	-
Dot Matrix	480 x RGB x 272	Pixel
Module Size (W x H x T)	105.5 x 67.2 x 3.95	mm.
Active Area (W x H)	95.04 x 53.856	mm.
Pixel Size ( W×H )	0.198 x 0.198	mm.
Color depth	16.7M	color
Interface	Parallel 24-bit RGB	-
Driving IC Package	COG	-
Module weight	55	g

### 1.2 Display specification

Display	Descriptions	Note
LCD Type	a-Si TFT	-
LCD Mode	TN / Normal white	-
Polarizer Mode	Transmissive	-
Polarizer Surface	Normal	-
Pixel arrangement	RGB-stripe	-
Backlight Type	LED	-
Viewing Direction(Gray inversion)	12 O'clock Direction	-

\* Color tone is slightly changed by temperature and driving voltage.

# 1.3 Outline dimension

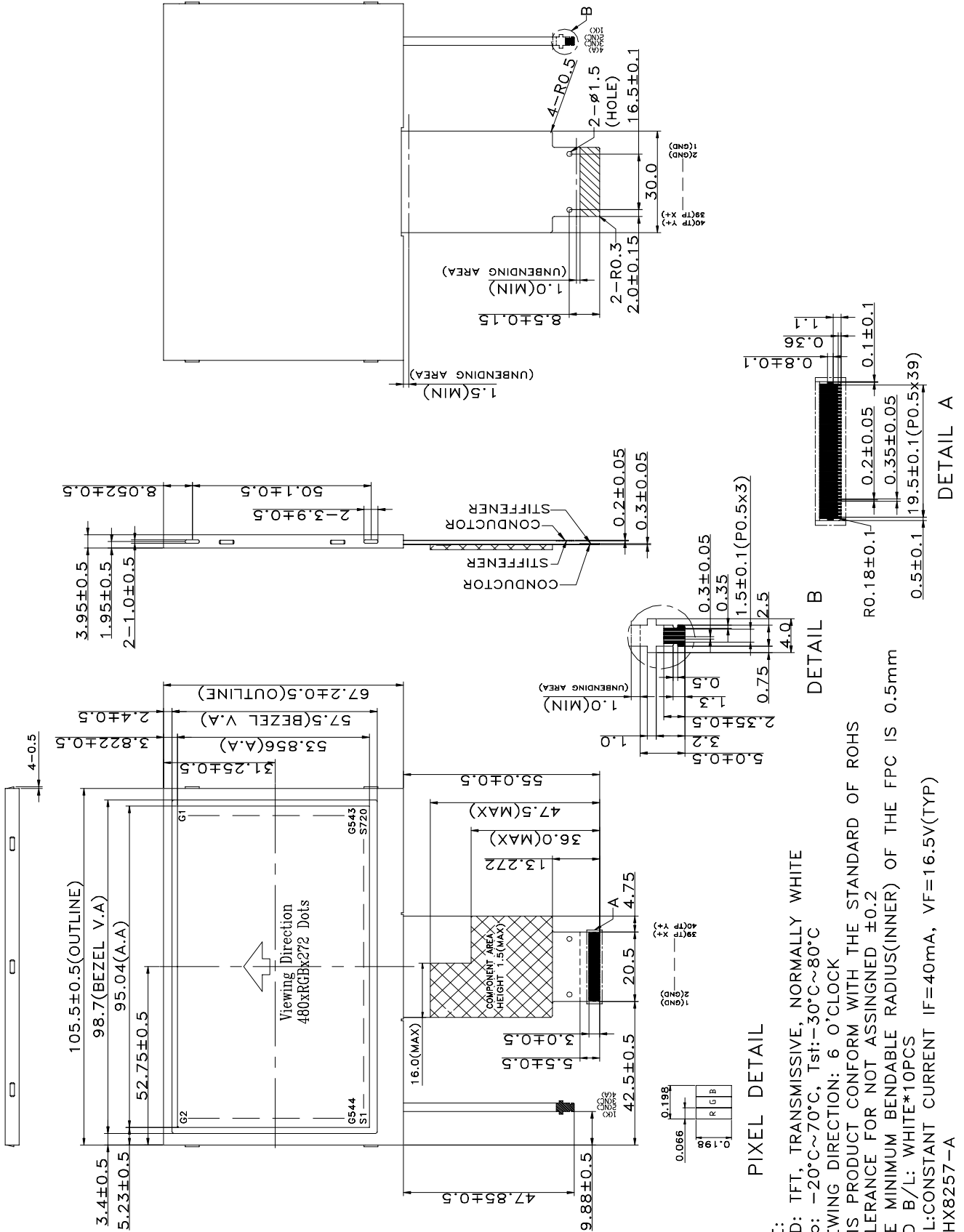

- NOTE:**
- 1.LCD: TFT, TRANSMISSIVE, NORMALLY WHITE
  - 2.Top: -20°C~70°C, Tst:-30°C~80°C
  - 3.VIEWING DIRECTION: 6 O'CLOCK
  - 4.THIS PRODUCT CONFORM WITH THE STANDARD OF ROHS
  - 5.TOLERANCE FOR NOT ASSIGNED ±0.2
  - 6.THE MINIMUM BENDABLE RADIUS(INNER) OF THE FPC IS 0.5mm
  - 7.LED B/L: WHITE\*10PCS
  - 8.B/L:CONSTANT CURRENT IF=40mA, VF=16.5V(TYP)
  - 9.IC:HX8257-A

**1.4 Block diagram:**

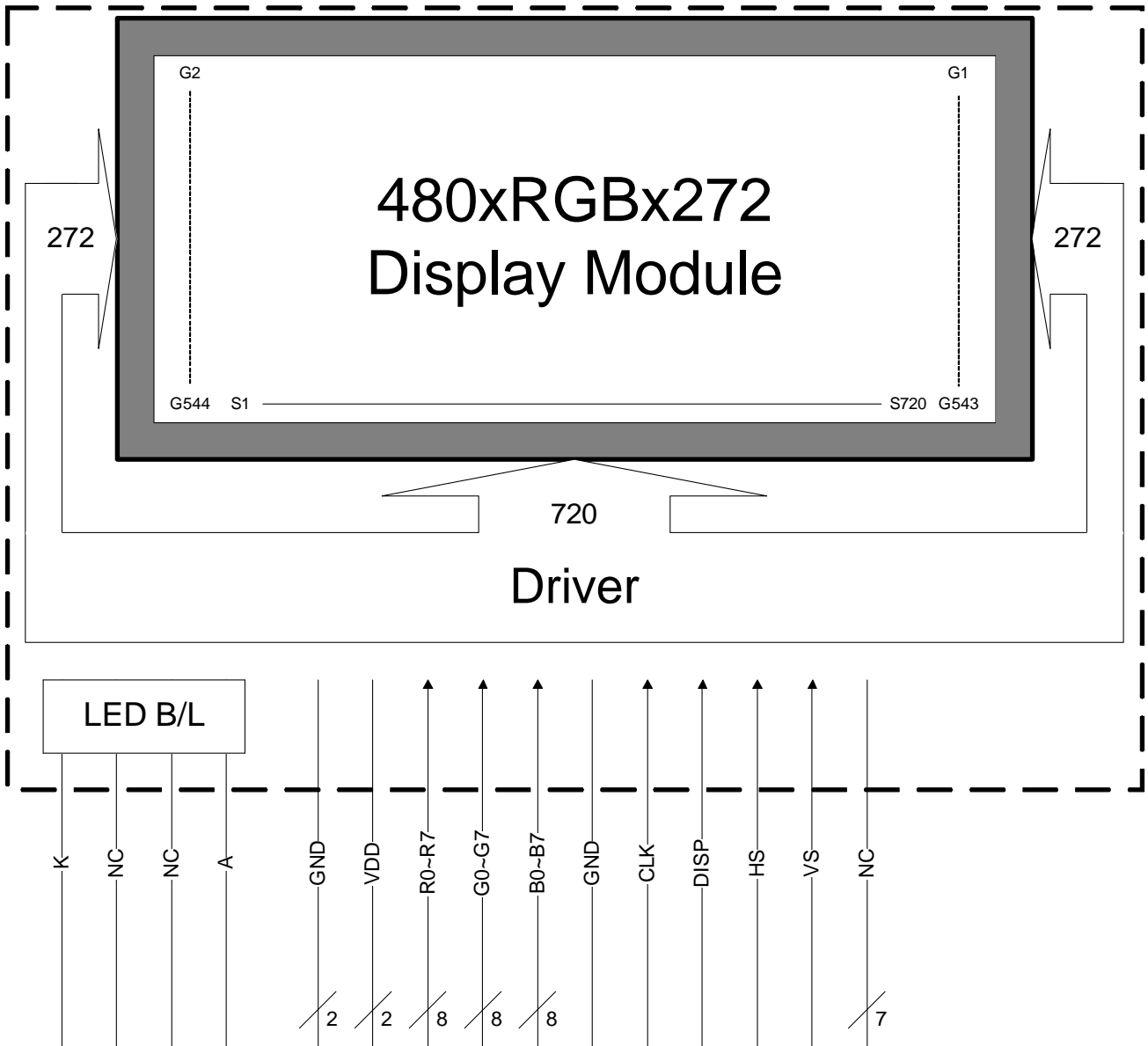

### 1.5 Interface pin :

Pin No.	Pin Symbol	I/O	Description
1 ~ 2	GND	P	Ground for logic. (0V)
3 ~ 4	VDD	P	Power supply. (+3.3V)
5 ~ 12	R0 ~ R7	I	Red data signal.
13 ~ 20	G0 ~ G7	I	Green data signal.
21 ~ 28	B0 ~ B7	I	Blue data signal.
29	GND	P	Ground for logic. (0V)
30	CLK	I	Clock signal for data latching and internal counter of the timing controller.
31	DISP	I	Display on/off mode control. Internally pulled high. (a) DISP=L, standby mode. (b) DISP=H, normal display mode.
32	HS	I	Horizontal sync input with negative polarity. Internally pull high.
33	VS	I	Vertical sync input with negative polarity. Internally pull high.
34 ~ 40	NC	-	No connect.

### B/L interface pin :

Pin No.	Pin Symbol	I/O	Description
1	K	P	Ground pin for backlight.
2 ~ 3	NC	-	No connect.
4	A	P	Power supply input pin for backlight.



## 2. ELECTRICAL CHARACTERISTICS

### 2.1 Absolute Maximum Ratings

Items	Symbol	Min.	Max.	Unit
Power supply voltage	VDD	-0.3	4.0	V
Operate temperature range	T <sub>OP</sub>	-20	70	°C
Storage temperature range	T <sub>ST</sub>	-30	80	°C

## 2.2 DC Characteristics

$T_a = 25^\circ\text{C}$

Items	Symbol	Min.	Typ.	Max.	Unit	Condition
Supply voltage	VDD	3.0	3.3	3.6	V	-
Input Voltage	$V_{IL}$	0	-	$0.3V_{DD}$	V	L level
	$V_{IH}$	$0.7V_{DD}$	-	VDD	V	H level
Current consumption	$I_{VDD}$	-	-	25.5	mA	Note 1

\*Note1 :

Measuring Condition:

Standard Value MAX.

$T_a = 25^\circ\text{C}$

VDD -GND = 3.3V

Display Pattern = Check pattern



0 gray black pattern

### 2.2.1 Back-light Characteristics

PARAMETER	SYMBOL	MIN	TYP	MAX	Unit	Test Condition	NOTE
Supply Current	If	-	40	-	mA	$T_a = 25^\circ\text{C}$	-
Supply Voltage	Vf	-	16.5	-	V	$T_a = 25^\circ\text{C}$	-
Half-Life Time	Lf	-	50000	-	hrs	$T_a = 25^\circ\text{C}$	1

Note 1 : The " Half-Life Time" is defined as the LED chip brightness decreases to 50% than original brightness, Based on  $T_a 25 \pm 2^\circ\text{C}$ ,  $60 \pm 10\%$  RH condition .

## 2.3 AC Characteristics

### Parallel RGB Input Timing Requirement

Parameter	Symbol	Spec.			Unit
		Min.	Typ.	Max.	
Clock cycle	$f_{CLK}^{(1)}$	-	9	15	MHz
Hsync cycle	1/th	-	17.14	-	KHz
Vsync cycle	1/tv	-	59.94	-	Hz
Horizontal Signal					
Horizontal cycle	th	525	525	605	CLK
Horizontal display period	thd	480	480	480	CLK
Horizontal front porch	thf	2	2	82	CLK
Horizontal pulse width	thp <sup>(2)</sup>	2	41	41	CLK
Horizontal back porch	thb <sup>(2)</sup>	2	2	41	CLK
Vertical Signal					
Vertical cycle	tv	285	286	399	H <sup>(1)</sup>
Vertical display period	tvd	272	272	272	H <sup>(1)</sup>
Vertical front porch	tvf	1	2	227	H <sup>(1)</sup>
Vertical pulse width	tvp <sup>(2)</sup>	1	10	11	H <sup>(1)</sup>
Vertical back porch	tvb <sup>(2)</sup>	1	2	11	H <sup>(1)</sup>

**Note:** (1) Unit: CLK=1/  $f_{CLK}$  , H= th,

(2) It is necessary to keep  $tvp+tvb=12$  and  $thp+thb=43$  in sync mode. DE mode is unnecessary to keep it.

# Interface Timing Chart

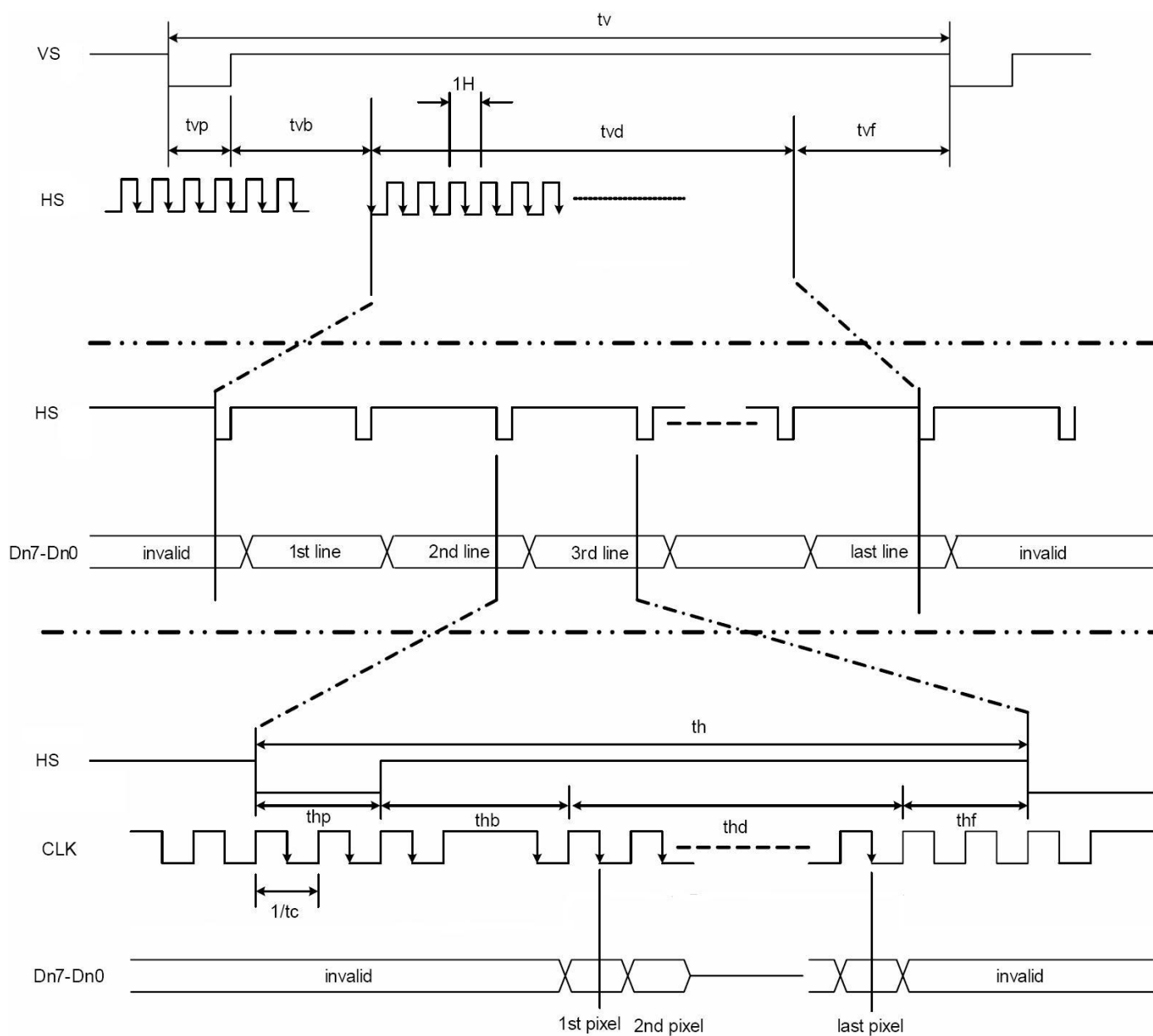

## Parallel RGB Input timing

### Input Setup Timing Requirement

Parameter	Symbol	Spec.			Unit
		Min.	Typ.	Max.	
DISP setup time	$t_{diss}$	10	-	-	ns
DISP hold time	$t_{dish}$	10	-	-	ns
Clock period	$PW_{CLK}^{(2)}$	66.7	-	-	ns
Clock pulse high period	$PWH^{(2)}$	26.7	-	-	ns
Clock pulse low period	$PWL^{(2)}$	26.7	-	-	ns
Hsync setup time	$t_{hs}$	10	-	-	ns
Hsync hold time	$t_{hh}$	10	-	-	ns
Data setup time	$t_{ds}$	10	-	-	ns
Data hold time	$t_{dh}$	10	-	-	ns
DE setup time	$t_{des}$	10	-	-	ns
DE hold time	$t_{deh}$	10	-	-	ns
Vsync setup time	$t_{vhs}$	10	-	-	ns
Vsync hold time	$t_{vhh}$	10	-	-	ns

Note: (1)  $t_r$ ,  $t_f$  is defined 10% to 90% of signal amplitude.

(2) For parallel interface, maximum clock frequency is 15MHz.

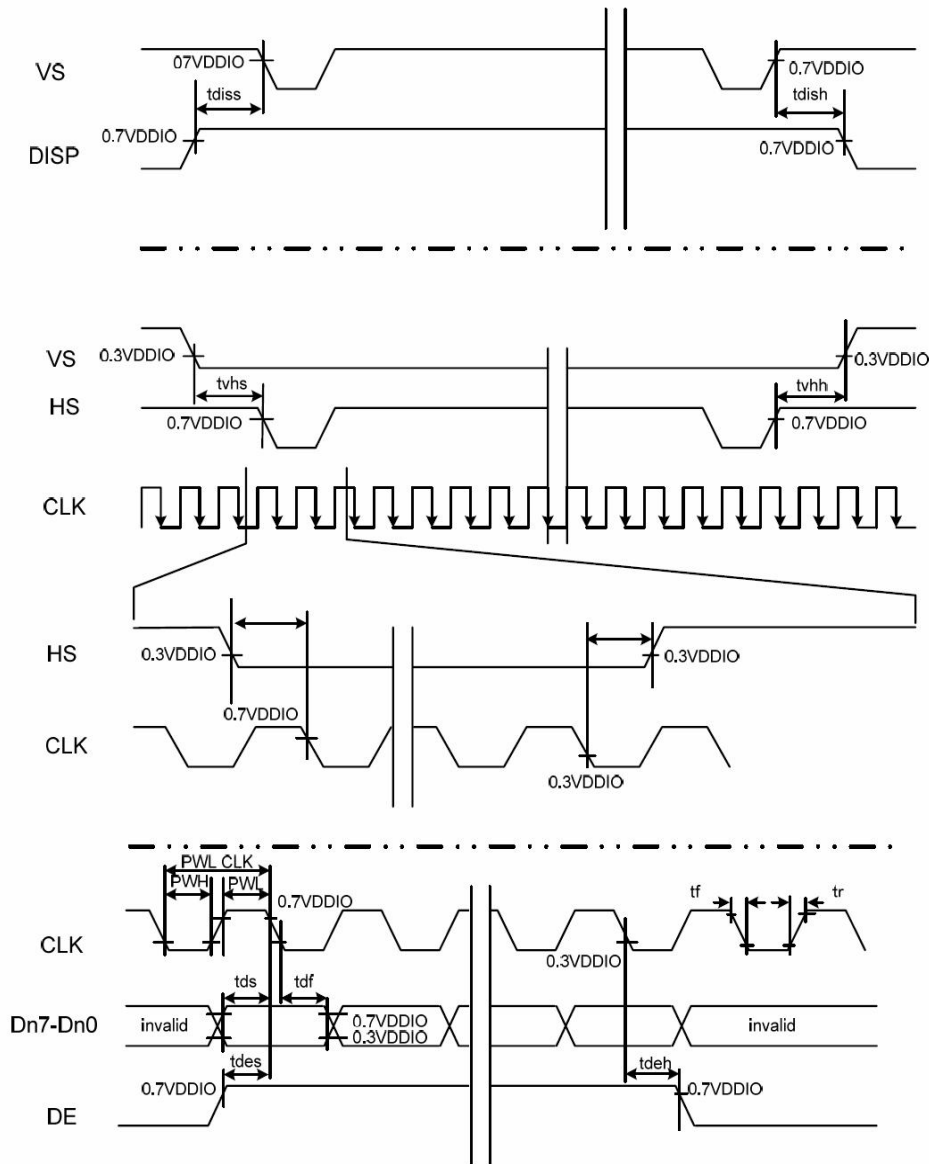

### 3. OPTICAL CHARACTERISTICS

#### 3.1 Characteristics

Electrical and Optical Characteristics

No.	Item			symbol / temp.	Min.	Typ.	Max.	Unit	Note	
1	Response Time			Tr	25 °C	-	5	ms	2	
				Tf	25 °C	-	15			
2	Viewing Angle	Hor.	Cr>=10	$\Theta_{2+}$	0°	45	80	-	degree	3
				$\Theta_{2-}$	180°	45	80	-		
		Ver.		$\Theta_{1+}$	270°	35	60	-		
				$\Theta_{1-}$	90°	45	80	-		
3	Contrast Ratio			Cr	25 °C	-	500	-	4	
4	Red x-code			Rx	25 °C	0.56	0.61	0.66	-	5
	Red y-code			Ry		0.31	0.36	0.41		
	Green x-code			Gx		0.28	0.33	0.38		
	Green y-code			Gy		0.53	0.58	0.63		
	Blue x-code			Bx		0.09	0.14	0.19		
	Blue y-code			By		0.07	0.12	0.17		
	White x-code			Wx		0.27	0.32	0.37		
	White y-code			Wy		0.30	0.35	0.40		
	Brightness			Y		400	500	-		
5	Brightness Uniformity				25 °C	80	-	-	%	6

### 3.2 Definition of optical characteristics

Measurement condition :

Transmissive and Transflective type

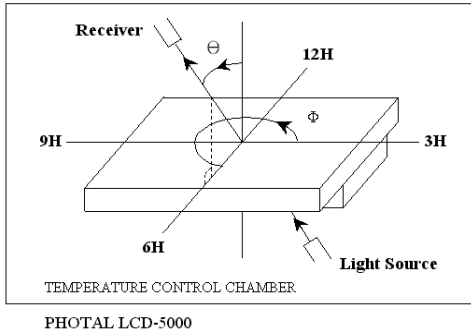

[Note 1] Definition of LCD Driving Vop and Waveform :

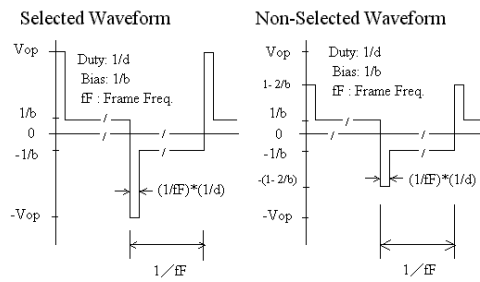
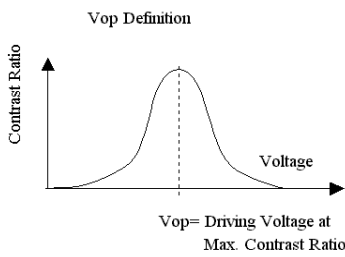

[Note 2] Definition of Response Time

for Positive type :

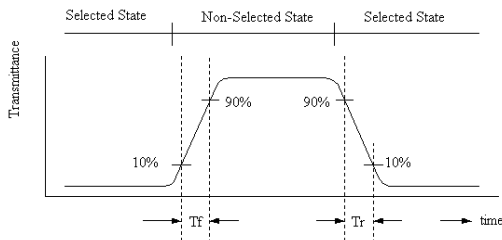

[Note 3] Definition of Viewing Angle :

[Note 4] Definition of Contrast Ratio :

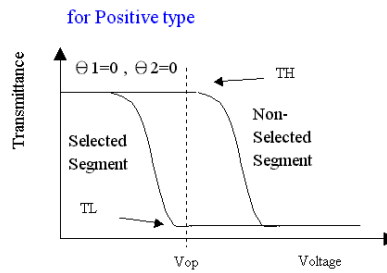
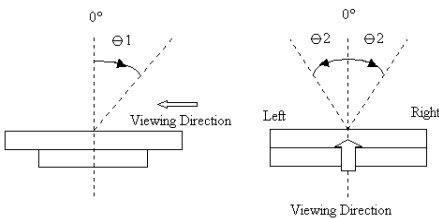

$$\text{Contrast Ratio} = \frac{TH}{TL}$$

**[Note 5] Definition of measurement of Color Chromaticity and Brightness**

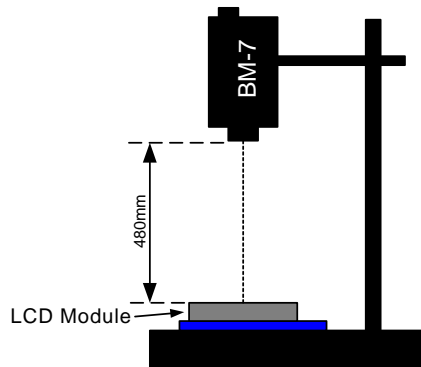

**[Note 6] Definition of Brightness Uniformity**

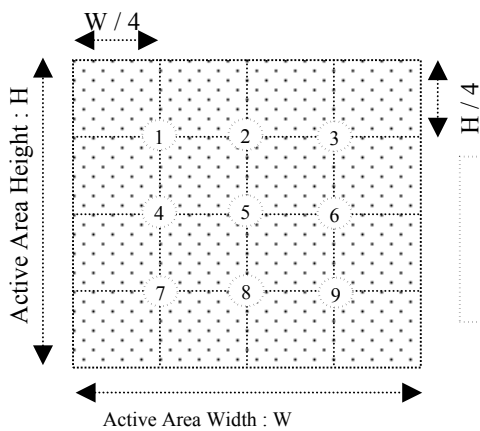

$$\text{Brightness Uniformity} = \frac{\text{Minimum Brightness of Point 1~9}}{\text{Maximum Brightness of Point 1~9}}$$

**[Note 7] Definition of Measurement of Reflectance**

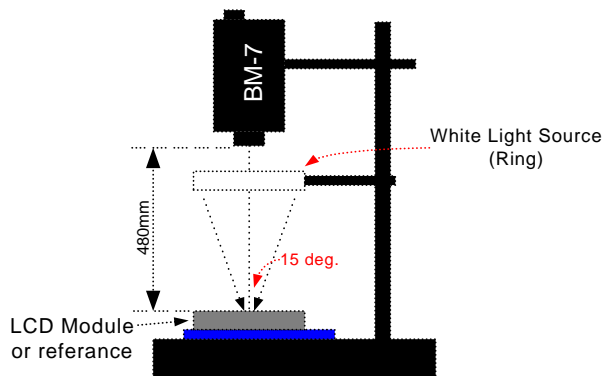



#### 4. RELIABILITY :

Item No	Items	Condition
1	High temperature operating	70 °C , 200 hours
2	Low temperature operating	-20 °C , 200 hours
3	High temperature storage	80 °C , 200 hours
4	Low temperature storage	-30 °C , 200 hours
5	High temperature & humidity storage	60°C, 90%RH, 100 hours
6	Thermal Shock storage	-30°C, 30min.<=> 80°C, 30min. 10 Cycles
7	Vibration test	10 => 55 =>10 => 55 => 10 Hz , within 1 minute Amplitude : 1.5mm. 15 minutes for each Direction ( X,Y,Z )
8	Drop test	Packed, 100CM free fall, 6 sides, 1 corner, 3edges
9	Life time	50,000 hours 25°C , 70%RH below , specification condition driving

- \* One single product test for only one item.
- \* Judgment after test : keep in room temperature for more than 2 hours.
  - Current consumption < 2 times of initial value
  - Contrast > 1/2 initial value
  - Function : work normally

## 5. PRODUCT HANDLING AND APPLICATION

### PRECAUTION FOR HANDLING LCM

The LCD module contains a C-MOS LSI. People who operate the LCM should wear ESD protection equipment to prevent ESD hurt on products.

Do not input any signal before power is turned on.

Do not take LCM from its packaging bag until it is assembled.

Peel off the LCM protective film slowly since static electricity may be generated.

Pay attention to the humidity of the work shop, 50~60%RH is satisfactory.

Use a non-leak iron for soldering LCM.

Do not touch the display surface or connection terminals area with bare hands. Smudges on the display surface reduce the insulation between terminals.

Cautions for soldering to LCM:

Condition for soldering I/O terminals:

Temperature at iron tip :280 ±10 .

Soldering time : 3~4sec./ terminals.

Type of solder : Eutectic solder(rosin flux filled).

### PRECAUTION IN USE OF LCD

Do not contact or scratch the front surface and the contact pads of a LCD panel with hard materials such as metal or glass or with one's nail.

To clean the surface , wipe it gently with soft cloth dampened by alcohol.

Do not attempt to wipe off the contact pads.

Keep LCD panels away from direct sunlight , also avoid them in high-temperature & high humidity environment for a long period.

Do not drive LCD panels by DC voltage.

Do not expose LCD panels to organic solvent.

Liquid in LCD is hazardous substance. In case a contact with liquid crystal material is occurred, be sure to immediately wash such material away by soap and water.

The polarizer is easily damaged and should be handle with special care. Don't press or rub it with hard objects.

### PRECAUTION FOR STORING LCM

To avoid degradation of the device , do not store the module under the conditions of direct sunlight , high temperature or high humidity . Keep the module in bags designed to prevent static electricity charging under low temperature / normal humidity conditions(avoid high temperature / high humidity and low temperature below 0 )

### USING ON MEDICAL CARE , SAFETY OR HAZARDOUS APPLICATION OR SYSTEM

For the application in medical care, safety and hazardous products or systems, an authorization from URT is required. URT will not responsible for any damage or loss which caused by the products without any authorization given by URT.

This product is not allowed to be designed and used for military application and/or purpose.

The delivery of this product to the countries and/or regions where the embargoes are imposed by U.N. is prohibited.

The application and delivery of this product must comply with Strategic High-Tech Commodities (SHTC) export control and the sales to the embargoed and/or sanctioned countries or regions are strictly prohibited.

## 6. DATE CODE OF PRODUCTS

Date code will be shown on each product :

Y MM DD - XXX  
|   |   |   |  
Year Month Day - Production lots

Example: 2 1 2 2 3 - 0 0 3 ==>Year 2002, Dec.,23rd , Batch no.03

## 7. PACKING

Instruction of lot number:

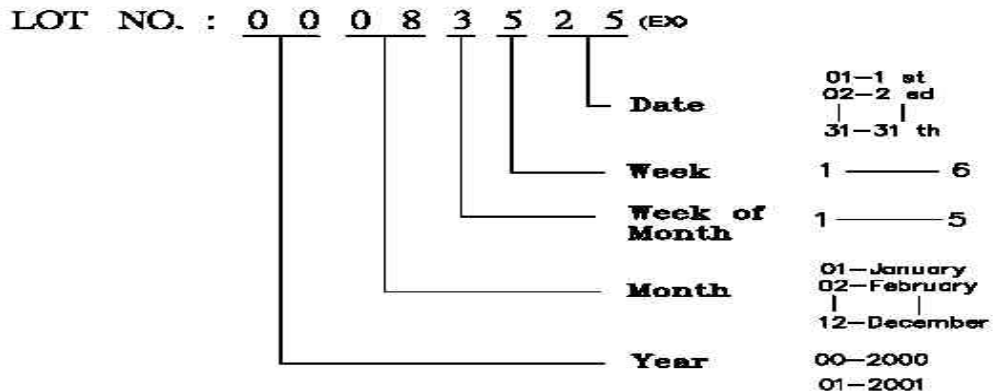

Label of carton:

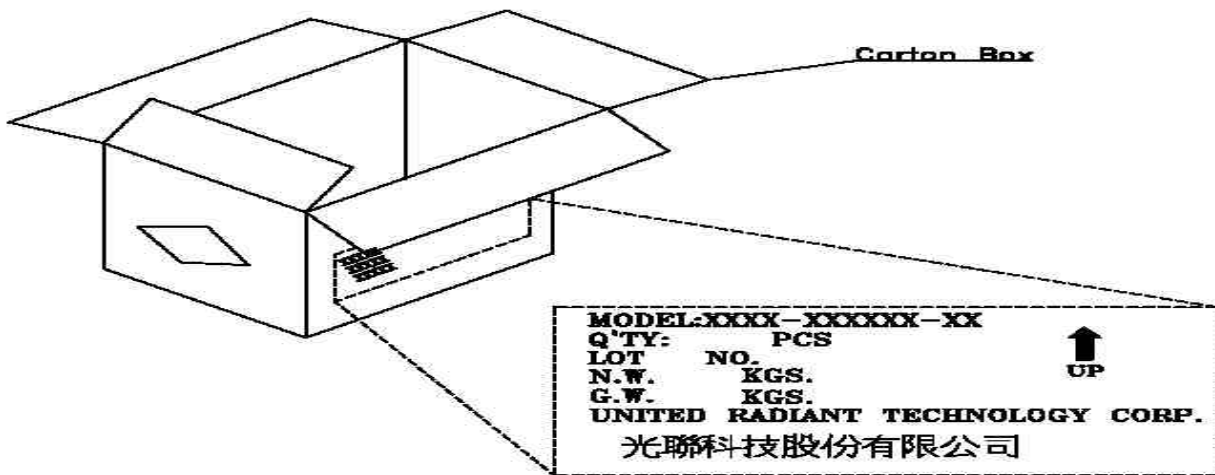

Packing tray must be stacked with alternated direction to each others.  
 To tacks packing trays in same direction will cause product damaged.

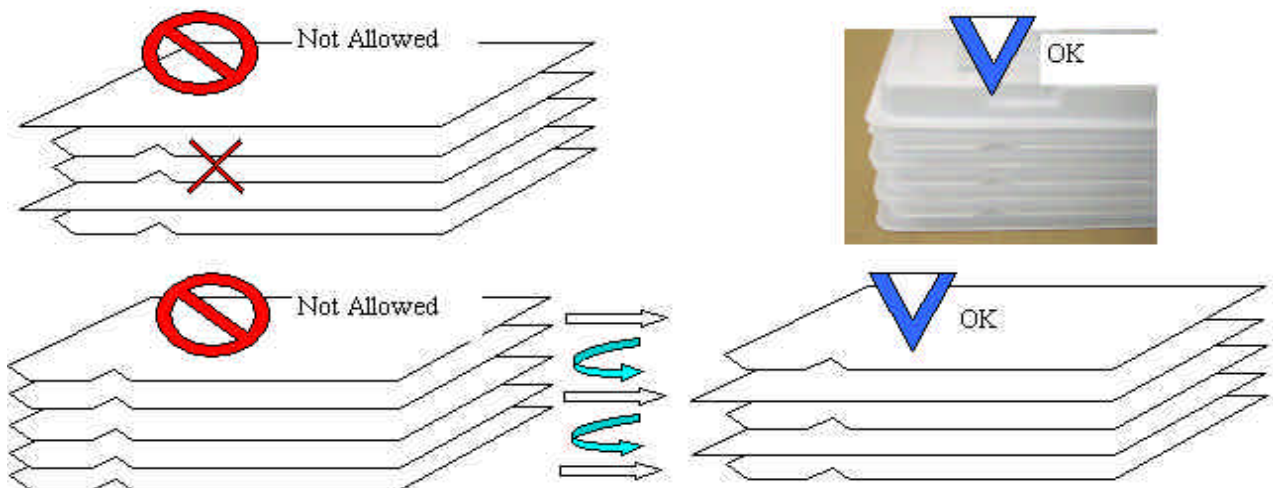

MODEL NO: UM\*

T.B.D.pcs / Tray

T.B.D.Tray / Box

T.B.D. Box / Carton

T.B.D.pcs / Carton

NOTE:

(1) Be warned, the direction of the tray has to turn it by 180 degree before stack it up. Otherwise, it will be packager's responsibility!!

(2) Safe Stack : 5 cartons only

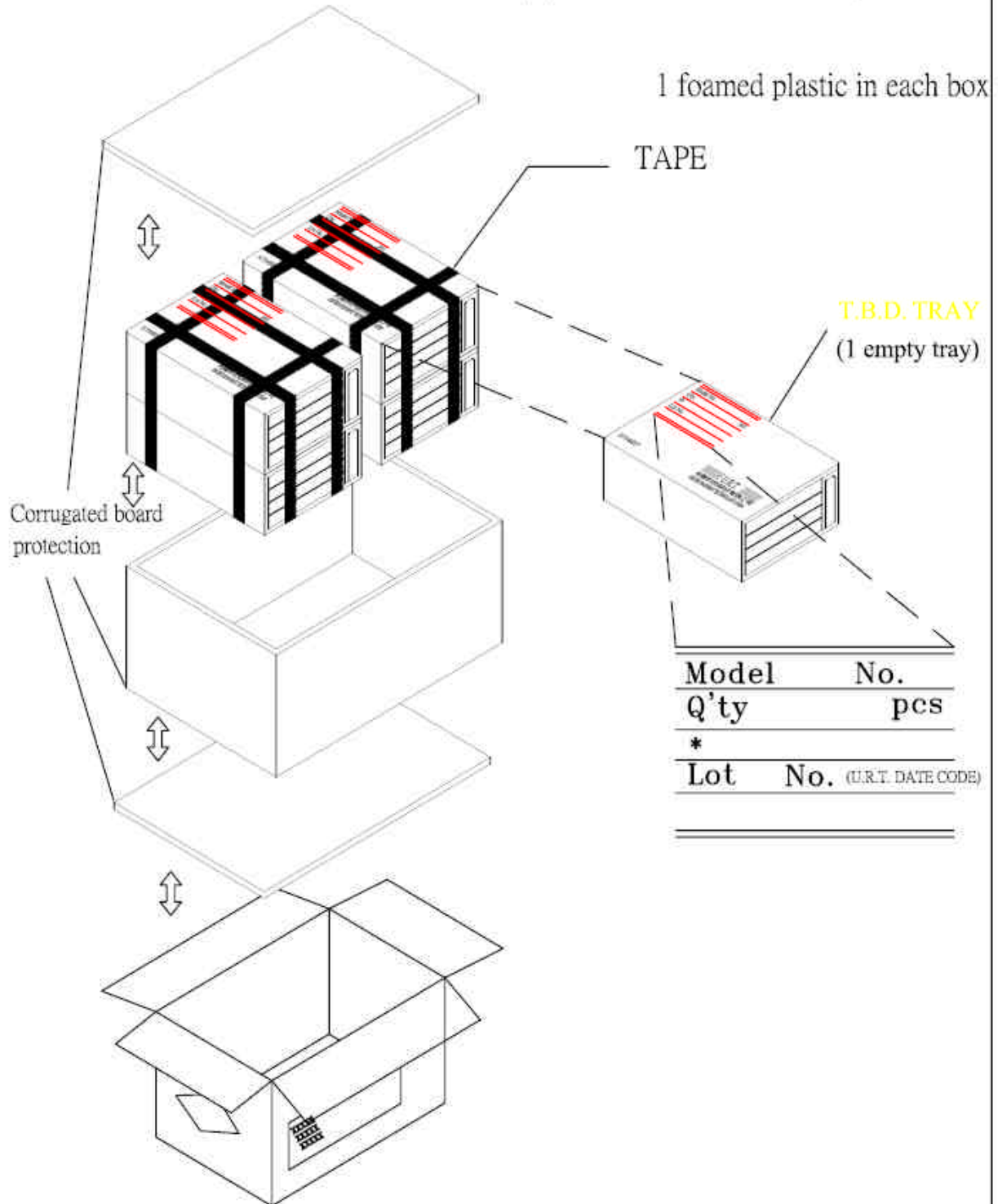

## 8. INSPECTION STANDARD

### 8.1. QUALITY :

THE QUALITY OF GOODS SUPPLIED TO PURCHASER SHALL COME UP TO THE FOLLOWING STANDARD.

#### 8.1.1. THE METHOD OF PRESERVING GOODS

AFTER DELIVERY OF GOODS FROM U.R.T. TO PURCHASER. PURCHASER SHALL CONTROL THE LCM AT -10 40 ,AND IT MIGHT BE DESIRABLE TO KEEP AT THE NORMAL ROOM TEMPERATURE AND HUMIDITY UNTIL INCOMING INSPECTION OR THROWING INTO PROCESS LINE.

#### 8.1.2. INCOMING INSPECTION

(A) THE METHOD OF INSPECTION

IF PURCHASER MAKE AN INCOMING INSPECTION , A SAMPLING PLAN SHALL BE APPLIED ON THE CONDITION THAT QUALITY OF ONE DELIVERY SHALL BE REGARDED AS ONE LOT.

(B) THE STANDARD OF QUALITY

ISO-2859-1 ( or MIL-STD-105E ), LEVEL SINGLE PLAN.

CLASS	AQL(%)
CRITICAL	0.4 %
MAJOR	0.65 %
MINOR	1.5 %
TOTAL	1.5 %

EVERY ITEM SHALL BE INSPECTED ACCORDING TO THE CLASS.

(C) MEASURE

IF AS THE RESULT OF ABOVE RECEIVING INSPECTION , A LOT OUT IS DISCOVERED. PURCHASER SHALL BE INFORM SELLER OF IT WITHIN SEVEN DAYS. BUT FIRST SHIPMENT WITHIN FOURTEEN DAYS.

#### 8.1.3. WARRANTY POLICY

U.R.T. WILL PROVIDE ONE-YEAR WARRANTY FOR THE PRODUCTS ONLY IF UNDER SPECIFICATION OPERATING CONDITIONS. U.R.T. WILL REPLACE NEW PRODUCTS FOR THESE DEFECT PRODUCTS WHICH UNDER WARRANTY PERIOD AND BELONG TO THE RESPONSIBILITY OF U.R.T.

## 8.2. CHECKING CONDITION

8.2.1. CHECKING DIRECTION SHALL BE IN THE 45 DEGREE AREA TO FACE THE SAMPLE.

8.2.2. CHECKER SHALL SEE OVER 30 cm. WITH BARE EYES FAR FROM SAMPLE AND USING 2 PCS. OF 20W FLUORESCENT LAMP.

### 8.3. INSPECTION PLAN :

CLASS	ITEM	JUDGEMENT	CLASS
PACKING & INDICATE	1. OUTSIDE AND INSIDE PACKAGE	"MODEL NO." , "LOT NO." AND "QUANTITY" SHOULD INDICATE ON THE PACKAGE.	Minor
	2. MODEL MIXED AND QUANTITY	OTHER MODEL MIXED.....REJECTED QUANTITY SHORT OR OVER.....REJECTED	Critical
	3. PRODUCT INDICATION	"MODEL NO." SHOULD INDICATE ON THE PRODUCT	Major
ASSEMBLY	4. DIMENSION, LCD GLASS SCRATCH AND SCRIBE DEFECT.	ACCORDING TO SPECIFICATION OR DRAWING.	Major
APPEARANCE	5. VIEWING AREA	POLARIZER EDGE OR LCD'S SEALING LINE IS VISABLE IN THE VIEWING AREA .....REJECTED	Minor
	6. BLEMISH, BLACK SPOT, WHITE SPOT IN THE LCD AND LCD GLASS CRACKS	ACCORDING TO STANDARD OF VISUAL INSPECTION ( INSIDE VIEWING AREA )	Minor
	7. BLEMISH, BLACK SPOT WHITE SPOT AND SCRATCH ON THE POLARIZER	ACCORDING TO STANDARD OF VISUAL INSPECTION ( INSIDE VIEWING AREA )	Minor
	8. BUBBLE IN POLARIZER	ACCORDING TO STANDARD OF VISUAL INSPECTION ( INSIDE VIEWING AREA )	Minor
	9. LCD'S RAINBOW COLOR	STRONG DEVIATION COLOR ( OR NEWTON RING) OF LCD.....REJECTED. OR ACCORDING TO LIMITED SAMPLE ( IF NEEDED, AND INSIDE VIEWING AREA )	Minor
ELECTRICAL	10. ELECTRICAL AND OPTICAL CHARACTERISTICS ( CONTRAST, VOP, CHROMATICITY ... ETC )	ACCORDING TO SPECIFICATION OR DRAWING . ( INSIDE VIEWING AREA )	Critical
	11.MISSING LINE	MISSING DOT, LINE, CHARACTER .....REJECTED	Critical
	12.SHORT CIRCUIT, WRONG PATTERN DISPLAY	NON DISPLAY, WRONG PATTERN DISPLAY, CURRENT CONSUMPTION OUT OF SPECIFICATION..... REJECTED	Critical
	13. PIN HOLE, PATTERN DEFORMITY	ACCORDING TO STANDARD OF VISUAL INSPECTION	Minor

### 8.4. STANDARD OF VISUAL INSPECTION

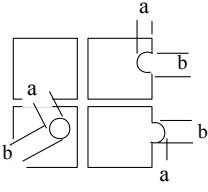
NO.	CLASS	ITEM	JUDGEMENT																																			
8.4.1	MINOR	<p>. BLEMISH, BLACK SPOT, WHITE SPOT IN THE LCD.</p> <p>. BLEMISH, BLACK SPOT, WHITE SPOT AND SCRATCH ON THE POLARIZER</p>	<p>(A) ROUND TYPE: <span style="float: right;">unit : mm.</span></p> <table border="1"> <thead> <tr> <th colspan="2">DIAMETER (mm.)</th> <th>ACCEPTABLE Q'TY</th> </tr> </thead> <tbody> <tr> <td colspan="2">0.1</td> <td>DISREGARD</td> </tr> <tr> <td>0.1 &lt;</td> <td>0.2</td> <td>2</td> </tr> <tr> <td>0.2 &lt;</td> <td>0.25</td> <td>1</td> </tr> <tr> <td>0.25 &lt;</td> <td></td> <td>0</td> </tr> </tbody> </table> <p>NOTE: <math>=(\text{LENGTH}+\text{WIDTH})/2</math></p> <p>(B) LINER TYPE: <span style="float: right;">unit : mm.</span></p> <table border="1"> <thead> <tr> <th>LENGTH</th> <th colspan="2">WIDTH</th> <th>ACCEPTABLE Q'TY</th> </tr> </thead> <tbody> <tr> <td>-----</td> <td>W</td> <td>0.03</td> <td>DISREGARD</td> </tr> <tr> <td>L 5.0</td> <td>0.03 &lt;</td> <td>W 0.05</td> <td>3</td> </tr> <tr> <td>L 5.0</td> <td>0.05 &lt;</td> <td>W 0.07</td> <td>1</td> </tr> <tr> <td>-----</td> <td>0.07 &lt;</td> <td>W</td> <td>FOLLOW ROUND TYPE</td> </tr> </tbody> </table>	DIAMETER (mm.)		ACCEPTABLE Q'TY	0.1		DISREGARD	0.1 <	0.2	2	0.2 <	0.25	1	0.25 <		0	LENGTH	WIDTH		ACCEPTABLE Q'TY	-----	W	0.03	DISREGARD	L 5.0	0.03 <	W 0.05	3	L 5.0	0.05 <	W 0.07	1	-----	0.07 <	W	FOLLOW ROUND TYPE
DIAMETER (mm.)		ACCEPTABLE Q'TY																																				
0.1		DISREGARD																																				
0.1 <	0.2	2																																				
0.2 <	0.25	1																																				
0.25 <		0																																				
LENGTH	WIDTH		ACCEPTABLE Q'TY																																			
-----	W	0.03	DISREGARD																																			
L 5.0	0.03 <	W 0.05	3																																			
L 5.0	0.05 <	W 0.07	1																																			
-----	0.07 <	W	FOLLOW ROUND TYPE																																			
8.4.2	MINOR	BUBBLE IN POLARIZER	<p style="text-align: right;">unit : mm.</p> <table border="1"> <thead> <tr> <th>DIAMETER</th> <th>ACCEPTABLE Q'TY</th> </tr> </thead> <tbody> <tr> <td>0.15</td> <td>DISREGARD</td> </tr> <tr> <td>0.15 &lt;</td> <td>2</td> </tr> <tr> <td>0.5 &lt;</td> <td>0</td> </tr> </tbody> </table>	DIAMETER	ACCEPTABLE Q'TY	0.15	DISREGARD	0.15 <	2	0.5 <	0																											
DIAMETER	ACCEPTABLE Q'TY																																					
0.15	DISREGARD																																					
0.15 <	2																																					
0.5 <	0																																					
8.4.3	MINOR	PIN HOLE , PATTERN DEFORMITY	<p style="text-align: right;">unit : mm.</p>  <table border="1"> <thead> <tr> <th>DIAMETER</th> <th>ACC. Q'TY</th> </tr> </thead> <tbody> <tr> <td>0.1</td> <td>DISREGARD</td> </tr> <tr> <td>0.1 &lt;</td> <td>3</td> </tr> <tr> <td>0.25 &lt;</td> <td>0</td> </tr> </tbody> </table> <p><math>= (a+b)/2</math></p>	DIAMETER	ACC. Q'TY	0.1	DISREGARD	0.1 <	3	0.25 <	0																											
DIAMETER	ACC. Q'TY																																					
0.1	DISREGARD																																					
0.1 <	3																																					
0.25 <	0																																					

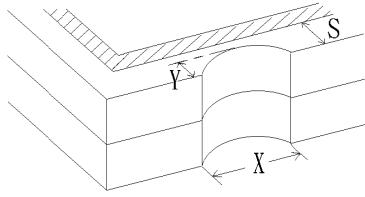
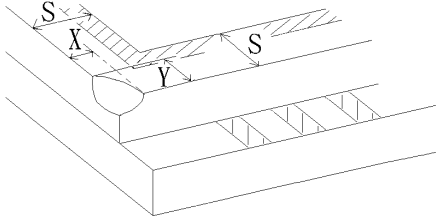
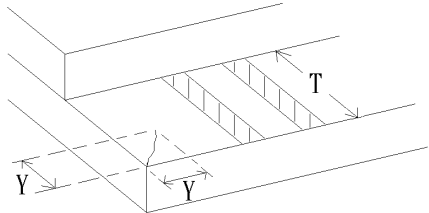
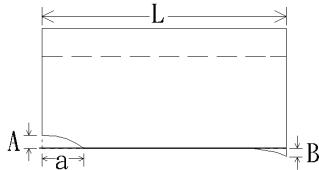
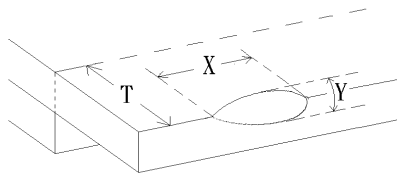
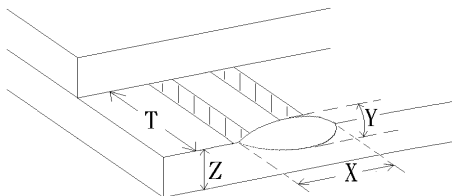
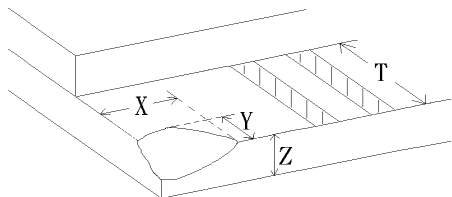

NO.	CLASS	ITEM	JUDGEMENT
8.4.4	MINOR	CHIPPING	 $Y > S$ REJ.
8.4.5	MINOR	CHIPPING	 $X \text{ or } Y > S$ REJ.
8.4.6	MAJOR	GLASS CRACK	 $Y > (1/2) T$ REJ.
8.4.7	MAJOR	SCRIBE DEFECT	 <ol style="list-style-type: none"> <li><math>a &gt; L/3</math>, <math>A &gt; 1.5\text{mm}</math>. REJ.</li> <li>B : ACCORDING TO DIMENSION</li> </ol>
8.4.8	MINOR	CHIPPING (ON THE TERMINAL AREA)	 $= (x+y)/2 > 2.5 \text{ mm}$ REJ.
8.4.9	MINOR	CHIPPING (ON THE TERMINAL SURFACE)	 $Y > (1/3) T$ REJ.
8.4.10	MINOR	CHIPPING	 $Y > T$ REJ.



Компания «ЭлектроПласт» предлагает заключение долгосрочных отношений при поставках импортных электронных компонентов на взаимовыгодных условиях!

Наши преимущества:

- Оперативные поставки широкого спектра электронных компонентов отечественного и импортного производства напрямую от производителей и с крупнейших мировых складов;
- Поставка более 17-ти миллионов наименований электронных компонентов;
- Поставка сложных, дефицитных, либо снятых с производства позиций;
- Оперативные сроки поставки под заказ (от 5 рабочих дней);
- Экспресс доставка в любую точку России;
- Техническая поддержка проекта, помощь в подборе аналогов, поставка прототипов;
- Система менеджмента качества сертифицирована по Международному стандарту ISO 9001;
- Лицензия ФСБ на осуществление работ с использованием сведений, составляющих государственную тайну;
- Поставка специализированных компонентов (Xilinx, Altera, Analog Devices, Intersil, Interpoint, Microsemi, Aeroflex, Peregrine, Syfer, Eurofarad, Texas Instrument, Miteq, Cobham, E2V, MA-COM, Hittite, Mini-Circuits, General Dynamics и др.);

Помимо этого, одним из направлений компании «ЭлектроПласт» является направление «Источники питания». Мы предлагаем Вам помощь Конструкторского отдела:

- Подбор оптимального решения, техническое обоснование при выборе компонента;
- Подбор аналогов;
- Консультации по применению компонента;
- Поставка образцов и прототипов;
- Техническая поддержка проекта;
- Защита от снятия компонента с производства.



#### Как с нами связаться

**Телефон:** 8 (812) 309 58 32 (многоканальный)

**Факс:** 8 (812) 320-02-42

**Электронная почта:** [org@eplast1.ru](mailto:org@eplast1.ru)

**Адрес:** 198099, г. Санкт-Петербург, ул. Калинина, дом 2, корпус 4, литера А.