

## FEATURES

### • High Performance Non-Blocking Switch Architecture

- 48-lane 12-port PCIe switch
- Integrated SerDes supports 8.0 GT/s Gen3, 5.0 GT/s Gen2 and 2.5 GT/s Gen1 operation
- Delivers up to 96 GBps (768 Gbps) of switching capacity
- Low latency cut-through architecture
- Multicast compliant to Spec
- Supports up to 2 KB maximum payload size
- Request metering for maximum system throughput

### • Standards and Compatibility

- PCI Express Base Specification 3.0 compliant
- Implements the following optional PCI Express features:
  - Advanced Error Reporting (AER) on all ports
  - Access Control Services (ACS)
  - Alternative Routing ID (ARI) ECN
  - Internal Error Reporting (IER) ECN
  - Atomic operations ECN
  - TLP processing hints (TPH) ECN
  - Latency Tolerance Reporting (LTR) ECN
  - Optimized Buffer Flush/Fill (OBFF) ECN
- PCI Power Management Spec
  - Supports D0, D3hot and D3 power management states
- Active State Power Management (ASPM)

### • Switch Initialization/Configurability

- Supports x8, x4, x2 and x1 ports
- Automatic per port link width negotiation
- Automatic lane reversal
- Autonomous and software managed link width and speed control
- Per lane SerDes configuration
- Supports Global and Local reference port clock input
- Crosslink support
- 9 General Purpose I/O
- Supports Root (BIOS, DS, or driver), Serial EEPROM, pin strapping, or SMBus switch initialization
- No power sequencing requirements

### • Multi-Root Support

- Supports up to 12 fully independent switch partitions
- Configurable downstream port device numbering
- Supports dynamic reconfiguration of switch partitions
- Movable upstream port within and between switch partitions

### • Reliability, Availability and Serviceability (RAS)

- ECRC support
- AER on all ports
- SECCED ECC protection on all internal RAMs
- End-to-end data path parity protection
- Ability to generate an interrupt (INTx or MSI) on link up/down transitions
- Hot-plug supported on all downstream switch ports
- On-chip link activity and status outputs available including the upstream ports
- Supports IEEE 1149.6 AC JTAG and IEEE 1149.1 JTAG

### • Development Tools

- 89KTPES48H12G3 Evaluation Board
- PCIe Browser Software
- Provides ODS (On-Die Scope)
- Built-in PRBS generator and checker
- Documentation and support at: [www.IDT.com](http://www.IDT.com)

### • Packaged in a 27mm x 27mm 676-ball FCBGA

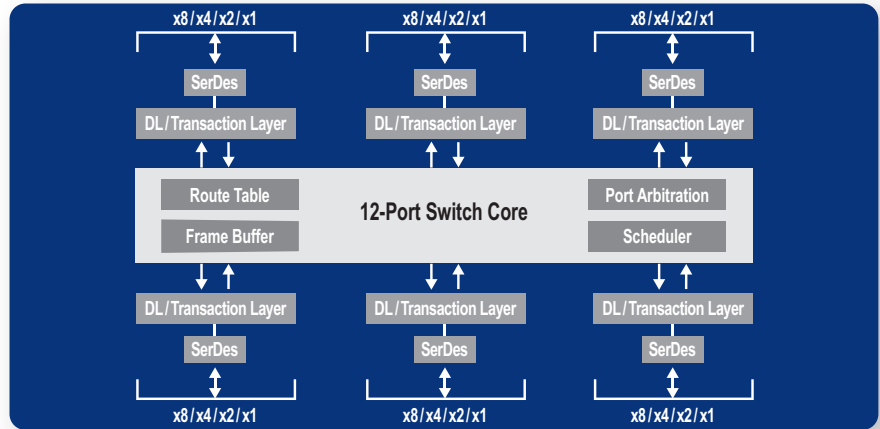

48 PCI Express Lanes - Up to 6 x8 ports or 12 x4 ports

## Device Overview

The 89H48H12G3 is a 48-lane, 12-port system interconnect switch optimized for PCI Express® Gen3 packet switching in high-performance applications, supporting multiple simultaneous peer-to-peer traffic flows. Target applications include servers, storage, communications, embedded systems, and multi-host or intelligent I/O based systems with inter-domain communication.

Utilizing standard PCI Express Gen3 interconnect, the 89H48H12G3 provides the most efficient system interconnect switching solution for applications requiring high throughput, low latency, and simple board layout with a minimum number of board layers. It provides 96 GBps (768 Gbps) of aggregated, full-duplex switching capacity through 48 integrated serial lanes, using proven and robust IDT technology. Each lane is capable of 8 GT/s of bandwidth in both directions and is fully compliant with PCI Express Base Specification 3.0.

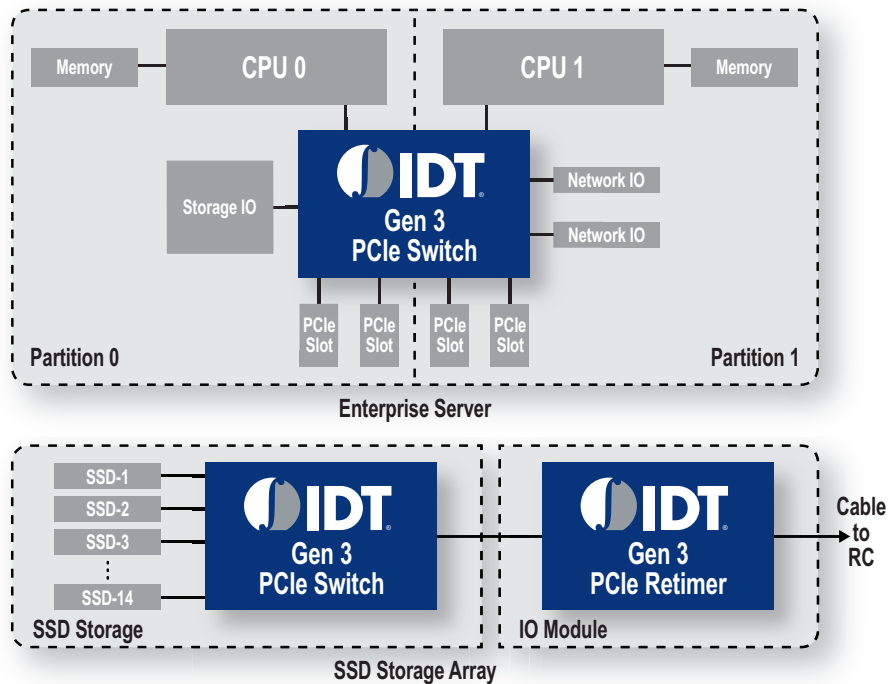

DISCLAIMER Integrated Device Technology, Inc. (IDT) and its subsidiaries reserve the right to modify the products and/or specifications described herein at any time and at IDT's sole discretion. All information in this document, including descriptions of product features and performance, is subject to change without notice. Performance specifications and the operating parameters of the described products are determined in the independent state and are not guaranteed to perform the same way when installed in customer products. The information contained herein is provided without representation or warranty of any kind, whether express or implied, including, but not limited to, the suitability of IDT's products for any particular purpose, an implied warranty of merchantability, or non-infringement of the intellectual property rights of others. This document is presented only as a guide and does not convey any license under intellectual property rights of IDT or any third parties. IDT's products are not intended for use in life support systems or similar devices where the failure or malfunction of an IDT product can be reasonably expected to significantly affect the health or safety of users. Anyone using an IDT product in such a manner does so at their own risk, absent an express, written agreement by IDT.

Integrated Device Technology, IDT and the IDT logo are registered trademarks of IDT. Other trademarks and service marks used herein, including protected names, logos and designs, are the property of IDT or their respective third party owners. © Copyright 2011. All rights reserved.

PB\_IDT89H48H12G3\_REVA0911



Компания «ЭлектроПласт» предлагает заключение долгосрочных отношений при поставках импортных электронных компонентов на взаимовыгодных условиях!

Наши преимущества:

- Оперативные поставки широкого спектра электронных компонентов отечественного и импортного производства напрямую от производителей и с крупнейших мировых складов;
- Поставка более 17-ти миллионов наименований электронных компонентов;
- Поставка сложных, дефицитных, либо снятых с производства позиций;
- Оперативные сроки поставки под заказ (от 5 рабочих дней);
- Экспресс доставка в любую точку России;
- Техническая поддержка проекта, помощь в подборе аналогов, поставка прототипов;
- Система менеджмента качества сертифицирована по Международному стандарту ISO 9001;
- Лицензия ФСБ на осуществление работ с использованием сведений, составляющих государственную тайну;
- Поставка специализированных компонентов (Xilinx, Altera, Analog Devices, Intersil, Interpoint, Microsemi, Aeroflex, Peregrine, Syfer, Eurofarad, Texas Instrument, Miteq, Cobham, E2V, MA-COM, Hittite, Mini-Circuits, General Dynamics и др.);

Помимо этого, одним из направлений компании «ЭлектроПласт» является направление «Источники питания». Мы предлагаем Вам помощь Конструкторского отдела:

- Подбор оптимального решения, техническое обоснование при выборе компонента;
- Подбор аналогов;
- Консультации по применению компонента;
- Поставка образцов и прототипов;
- Техническая поддержка проекта;
- Защита от снятия компонента с производства.



#### Как с нами связаться

**Телефон:** 8 (812) 309 58 32 (многоканальный)

**Факс:** 8 (812) 320-02-42

**Электронная почта:** [org@eplast1.ru](mailto:org@eplast1.ru)

**Адрес:** 198099, г. Санкт-Петербург, ул. Калинина, дом 2, корпус 4, литера А.