

## 800MHz BAND FRONT-END GaAs MMIC

### ■GENERAL DESCRIPTION

NJG1704KC1 is a front-end GaAs MMIC including a LNA, a local amplifier and a mixer, designed mainly for 800MHz band cellular phone handsets.

The ultra small & ultra thin FLP10-C1 package is applied.

### ■PACKAGE OUTLINE

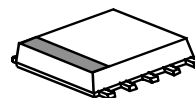

NJG1704KC1

### ■FEATURES

- Low Voltage Operation +2.7V typ.
- Low Current Consumption LNA 3.1mA typ.
- Mixer 6.1mA typ. (with local amplifier operation current)
- Ultra Small & Ultra Thin package FLP10-C1 (Package size: 3.0x2.8x0.75mm)
- LNA
  - High Small Signal Gain 16.5dB typ. @  $f_{RF}=820\text{MHz}$
  - Low Noise Figure 1.4dB typ. @  $f_{RF}=820\text{MHz}$
  - High Input IP3 -4.0dBm typ. @  $f_{RF}=820.0+820.1\text{MHz}$
- Mixer
  - High Conversion Gain 12.5dB typ. @  $f_{RF}=820\text{MHz}$ ,  $f_{LO}=690\text{MHz}$ ,  $P_{LO}=-10\text{dBm}$
  - Low Noise Figure 5.0dB typ. @  $f_{RF}=820\text{MHz}$ ,  $f_{LO}=690\text{MHz}$ ,  $P_{LO}=-10\text{dBm}$
  - High Input IP3 +1.0dBm typ. @  $f_{RF}=820.0+820.1\text{MHz}$ ,  $f_{LO}=690\text{MHz}$ ,  $P_{LO}=-10\text{dBm}$

### ■PIN CONFIGURATION

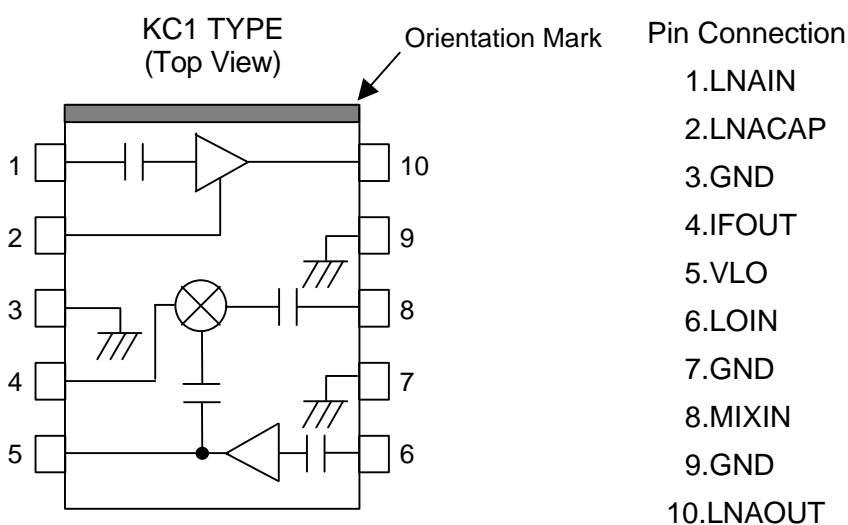

NOTE: Please note that any information on this catalog will be subject to change.

# NJG1704KC1

## ■ABSOLUTE MAXIMUM RATINGS

( $T_a=+25^{\circ}\text{C}$ ,  $Z_s=Z_l=50\Omega$ )

PARAMETER	SYMBOL	CONDITIONS	RATINGS	UNITS
LNA Voltage	$V_{LNA}$		5.0	V
Mixer Voltage	$V_{MIX}$		5.0	V
LOCAL Amplifier Voltage	$V_{LO}$		5.0	V
Input Power 1	$P_{LNAIN}$	$V_{LNA}=V_{MIX}=V_{LO}=2.7\text{V}$	+15	dBm
Input Power 2	$P_{LOIN}$	$V_{LNA}=V_{MIX}=V_{LO}=2.7\text{V}$	+10	dBm
Power Dissipation	$P_D$		550	mW
Operating Temperature	$T_{opr}$		-40~+85	$^{\circ}\text{C}$
Storage Temperature	$T_{sto}$		-55~+125	$^{\circ}\text{C}$

## ■ELECTRICAL CHARACTERISTICS 1 (LNA)

GENERAL CONDITIONS:  $T_a=+25^{\circ}\text{C}$ ,  $V_{LNA}=2.7\text{V}$ ,  $V_{MIX}=V_{LO}=0\text{V}$ ,  $f_{RF}=820\text{MHz}$ ,  $P_{RF}=-36\text{dBm}$ ,  $Z_s=Z_l=50\Omega$ , with test circuit

PARAMETER	SYMBOL	CONDITIONS	MIN	TYP	MAX	UNITS
Operating Frequency	freq		800	820	900	MHz
LNA Voltage	$V_{LNA}$		2.5	2.7	4.5	V
LNA Operating Current	$I_{LNA}$	$P_{RF}$ , $P_{LO}=\text{OFF}$	-	3.1	3.7	mA
Small Signal Gain	Gain		15.0	16.5	18.0	dB
Gain Flatness	$G_{flat}$	$f_{RF}=810\sim 885\text{MHz}$	-	0.5	1.0	dB
Noise Figure	NF		-	1.4	1.6	dB
Pout at 1dB Gain Compression point	$P_{-1dB}$		-3.0	-1.0	-	dBm
Input 3rd Order Intercept point	IIP3	$f_{RF}=820.0+820.1\text{MHz}$	-10.0	-4.0	-	dBm
RF IN VSWR	$VSWR_i$		-	1.6	2.0	
RF OUT VSWR	$VSWR_o$		-	1.5	2.0	

## ■ELECTRICAL CHARACTERISTICS 2 (Mixer)

GENERAL CONDITIONS:  $T_a=+25^{\circ}\text{C}$ ,  $V_{LNA}=0\text{V}$ ,  $V_{MIX}=V_{LO}=2.7\text{V}$ ,  $f_{RF}=820\text{MHz}$ ,  $f_{LO}=690\text{MHz}$ ,  $P_{RF}=-30\text{dBm}$ ,  $P_{LO}=-10\text{dBm}$ ,  $Z_s=Z_l=50\Omega$ , with test circuit

PARAMETER	SYMBOL	CONDITIONS	MIN	TYP	MAX	UNITS
Operating Frequency	freq		800	820	900	MHz
Mixer Voltage	$V_{MIX}$		2.5	2.7	4.5	V
Local Amplifier Voltage	$V_{LO}$		2.5	2.7	4.5	V
Mixer Operating Current	$I_{MIX}$	$P_{RF}$ , $P_{LO}=\text{OFF}$	-	5.0	6.3	mA
Local Amplifier Operating Current	$I_{LO}$	$P_{RF}$ , $P_{LO}=\text{OFF}$	-	1.0	1.2	mA
Conversion Gain	$G_c$		11.0	12.5	-	dB
Noise Figure	NF		-	5.0	7.0	dB
Input 3rd Order Intercept Point	IIP3	$f_{RF}=820.0+820.1\text{MHz}$	-	+1.0	-	dBm

## ■TERMINAL INFORMATION

No.	SYMBOL	FUNCTION
1	LNAIN	RF input terminal of LNA. An external matching circuit is required.
2	LNACAP	Terminal for the bypass capacitor of LNA. The bypass capacitor C1 as shown in test circuits, should be connected to this terminal as close as possible.
3	GND	Ground terminal(0V)
4	IFOUT	IF signal output terminal. The IF signal is output through external matching circuit connected to this terminal. Please connect inductances L7, L8 and power supply as shown in test circuits, since this terminal is also the terminal of mixer power supply.
5	VLO	Power supply terminal for local amplifier. Please place R1 and L10 as shown in test circuits at very close to this terminal.
6	LOIN	Local signal input terminal to local amplifier. An external matching circuit is required.
7	GND	Ground terminal(0V)
8	MIXIN	RF signal input terminal to mixer. An external matching circuit is required.
9	GND	Ground terminal(0V)
10	LNAOUT	Signal output terminal of LNA. The RF signal from LNA is output through external matching circuit connected to this terminal. Please connect inductances L3, L4 and power supply as shown in test circuits, since this terminal is also the terminal of LNA power supply.

### CAUTION

- 1) Ground terminal (No.3, 7, 9) should be connected to the ground plane as low inductance as possible.

# NJG1704KC1

## ■ TYPICAL CHARACTERISTICS (LNA, $f_{LO}=690\text{MHz}$ , with test circuit)

Gain, Noise Figure vs. Frequency

( $V_{LNA}=2.7\text{V}$ )

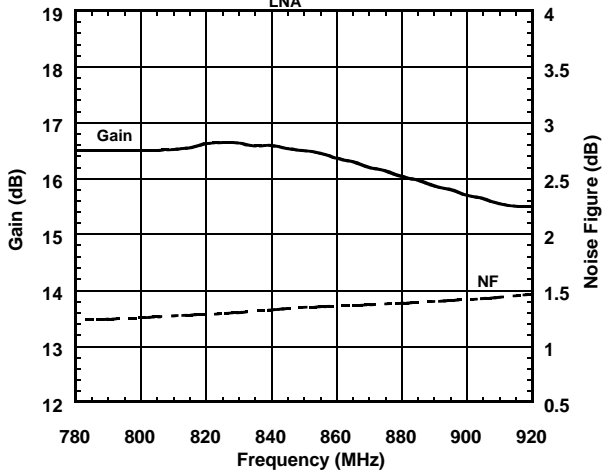

Pout vs. Pin

( $V_{LNA}=2.7\text{V}, f=820\text{MHz}$ )

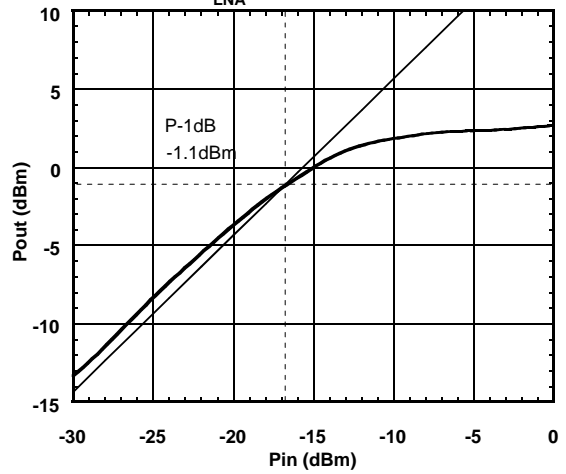

Pout, IM3 vs. Pin

( $V_{LNA}=2.7\text{V}, f=820.0+820.1\text{MHz}$ )

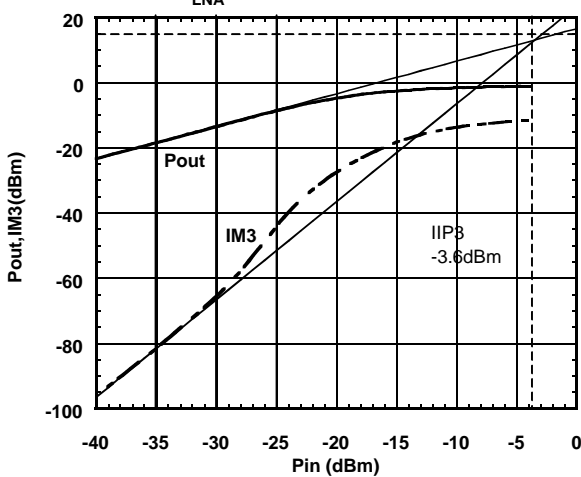

Gain, Noise Figure vs.  $V_{LNA}$

( $f=820\text{MHz}$ )

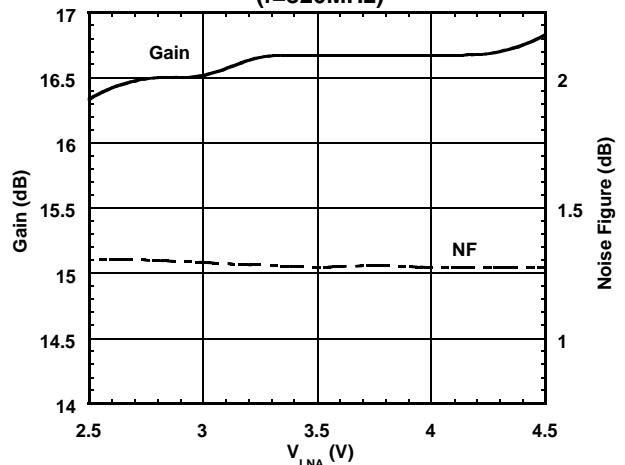

$I_{LNA}$  vs.  $V_{LNA}$

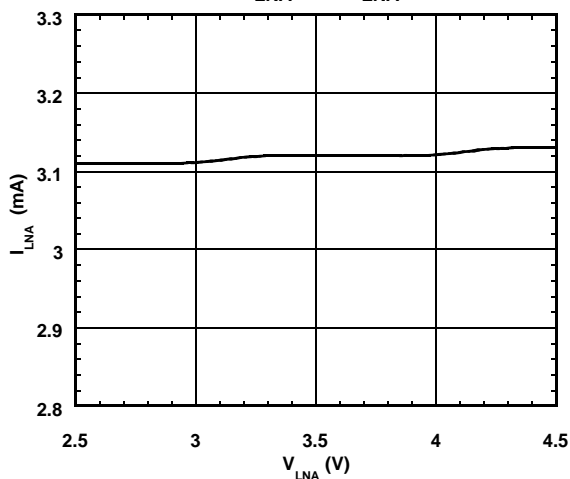

P-1dB vs.  $V_{LNA}$

( $f=820\text{MHz}$ )

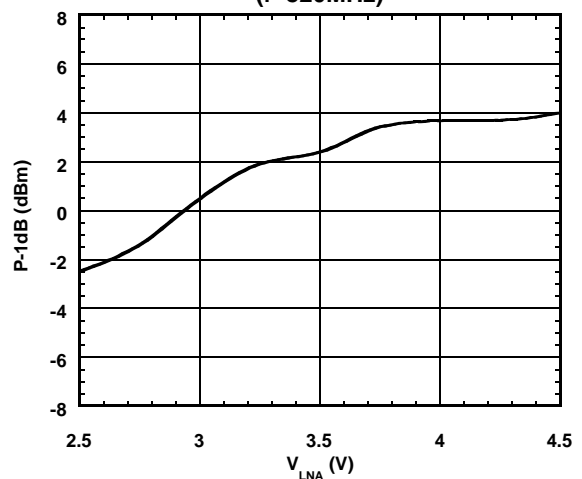

■ TYPICAL CHARACTERISTICS (LNA,  $f_{LO}=690\text{MHz}$ , with test circuit)

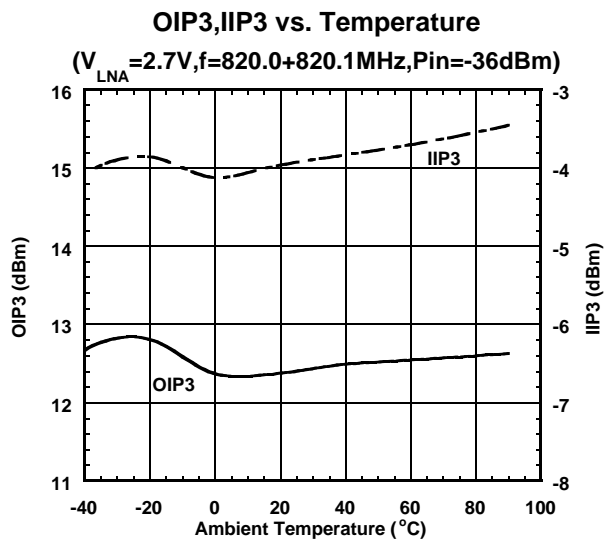
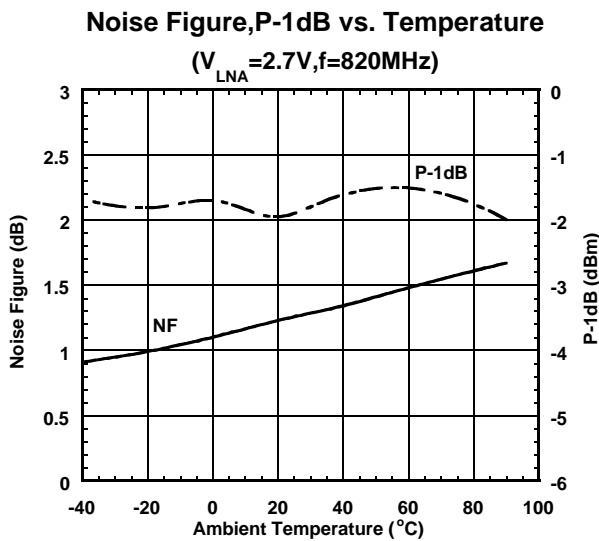
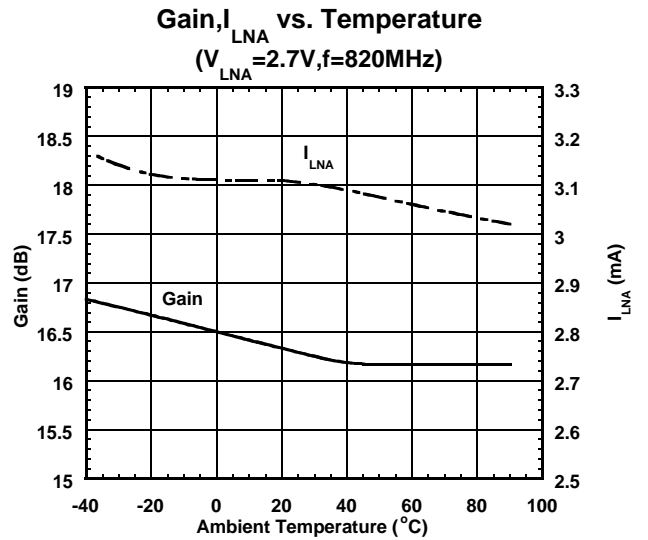
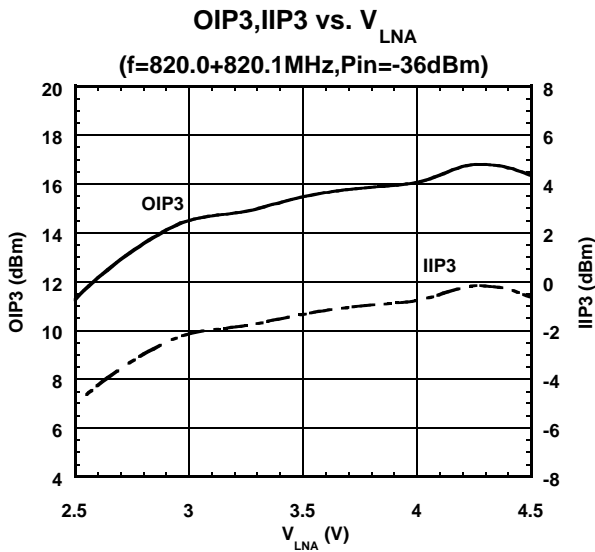

The value of OIP3 and IIP3 shown in typical characteristics are calculated by

$$\text{OIP3} = \frac{3 \times \text{Pout-1M3}}{2}$$

$$\text{IIP3} = \text{OIP3} - \text{Gain} \quad @ \text{Pin} = -36\text{dBm}$$

# NJG1704KC1

## ■TYPICAL CHARACTERISTICS (LNA, $f_{LO}=690\text{MHz}$ , with test circuit)

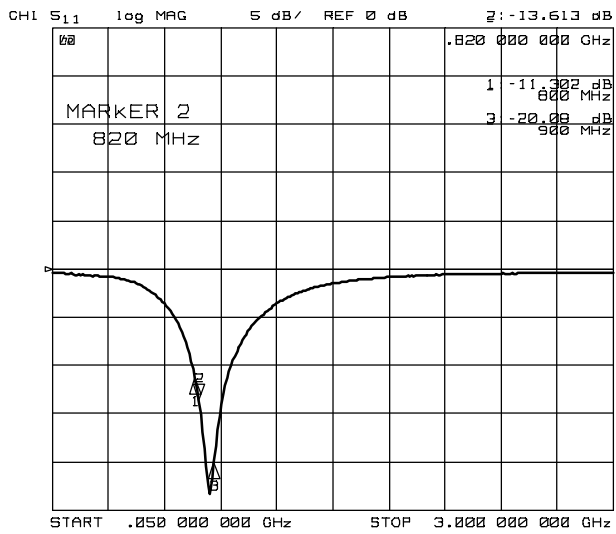

S11

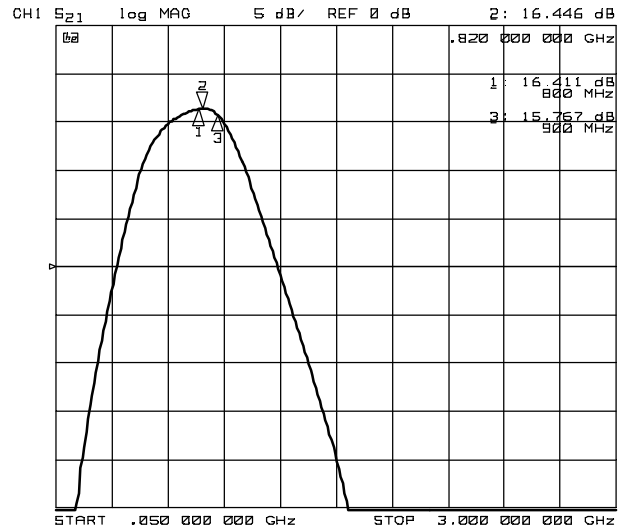

S21

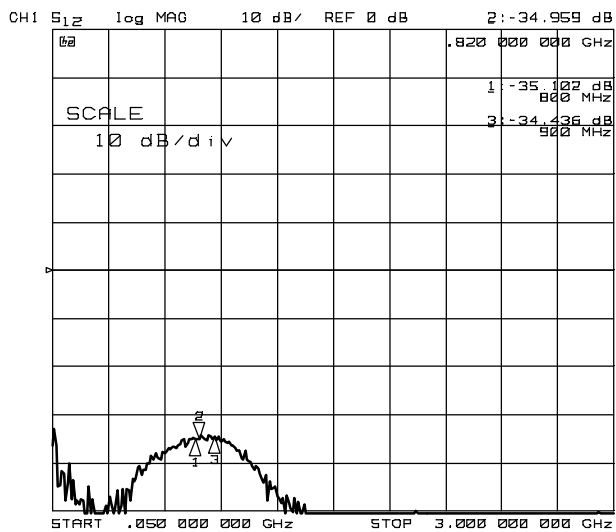

S12

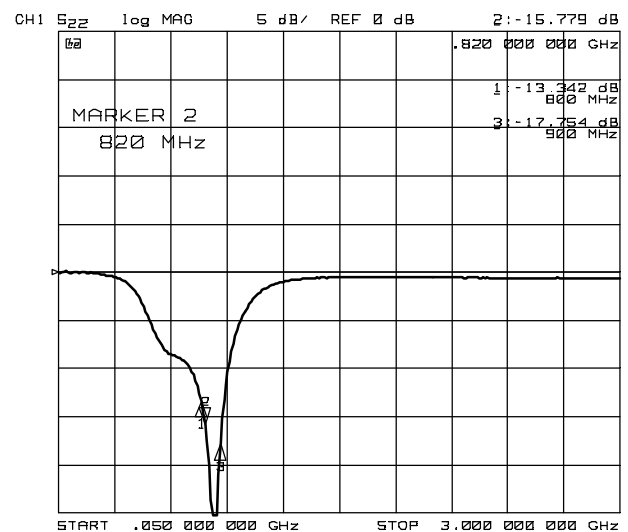

S22

Condition

$V_{LNA}=2.7\text{V}$

$V_{MIX}=V_{LO}=0\text{V}$

■ TYPICAL CHARACTERISTICS (MIXER,  $f_{LO}=690\text{MHz}$ , with test circuit)

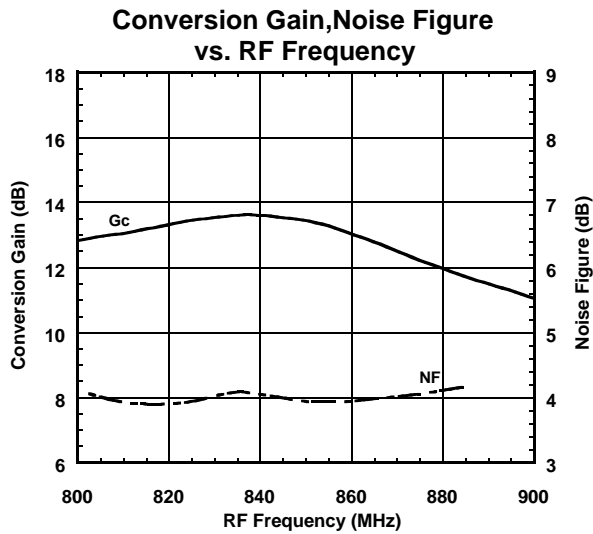

Condition  
 $f_{IF}=130\text{MHz}$   
 $P_{RF}=-30\text{dBm}$   
 $P_{LO}=-10\text{dBm}$   
 $V_{MIX}=V_{LO}=2.7\text{V}$   
 Lower Local

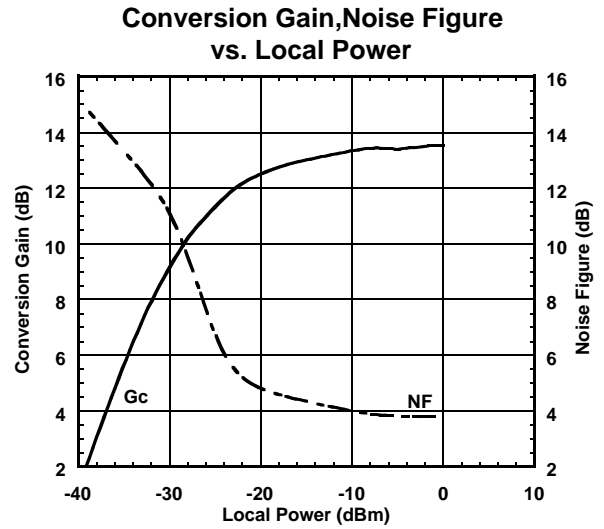

Condition  
 $f_{IF}=130\text{MHz}$   
 $f_{RF}=820\text{MHz}$ ,  $P_{RF}=-30\text{dBm}$   
 $f_{LO}=690\text{MHz}$   
 $V_{MIX}=V_{LO}=2.7\text{V}$

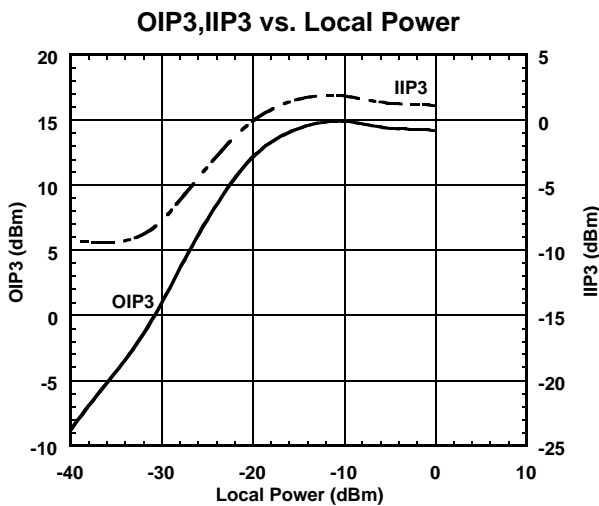

Condition  
 $f_{IF}=130\text{MHz}$   
 $f_{RF1}=820.0\text{MHz}$ ,  $P_{RF}=-30\text{dBm}$   
 $f_{RF2}=820.1\text{MHz}$   
 $f_{LO}=690\text{MHz}$   
 $V_{MIX}=V_{LO}=2.7\text{V}$

$$\text{OIP3} = \frac{3 \times \text{IF-IM3}}{2}$$

$$\text{IIP3} = \text{OIP3} - G_c$$
 @  $P_{RF} = -30\text{dBm}$

# NJG1704KC1

## ■ TYPICAL CHARACTERISTICS (MIXER, $f_{LO}=690\text{MHz}$ , with test circuit)

Conversion Gain, Noise Figure  
vs.  $V_{MIX}, V_{LO}$

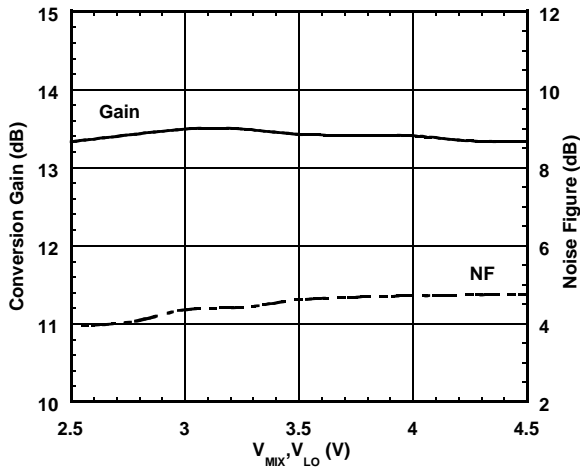

Condition

$f_{IF}=130\text{MHz}$   
 $f_{RF}=820\text{MHz}$ ,  $P_{RF}=-30\text{dBm}$   
 $f_{LO}=690\text{MHz}$ ,  $P_{LO}=-10\text{dBm}$

OIP3, IIP3 vs.  $V_{MIX}, V_{LO}$

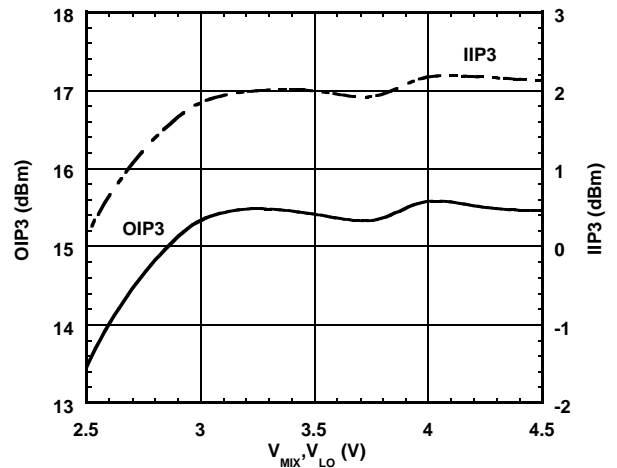

Condition

$f_{IF}=130\text{MHz}$   
 $f_{RF1}=820.0\text{MHz}$ ,  $P_{RF}=-30\text{dBm}$   
 $f_{RF2}=820.1\text{MHz}$   
 $f_{LO}=690\text{MHz}$ ,  $P_{LO}=-10\text{dBm}$

$$\text{OIP3} = \frac{3 \times \text{IF-IM3}}{2}$$
  

$$\text{IIP3} = \text{OIP3} - G_c$$
  
 @  $P_{RF} = -30\text{dBm}$

IF, IM3 vs. RF Power

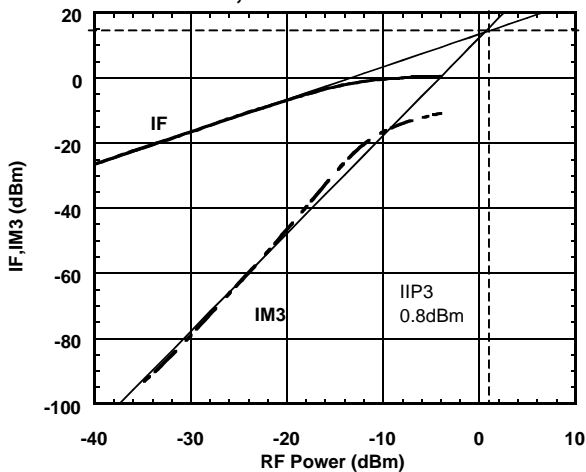

Condition

$f_{IF}=130\text{MHz}$   
 $f_{RF1}=820.0\text{MHz}$   
 $f_{RF2}=820.1\text{MHz}$   
 $f_{LO}=690\text{MHz}$ ,  $P_{LO}=-10\text{dBm}$   
 $V_{MIX}=V_{LO}=2.7\text{V}$

IF Output Power vs. RF Power

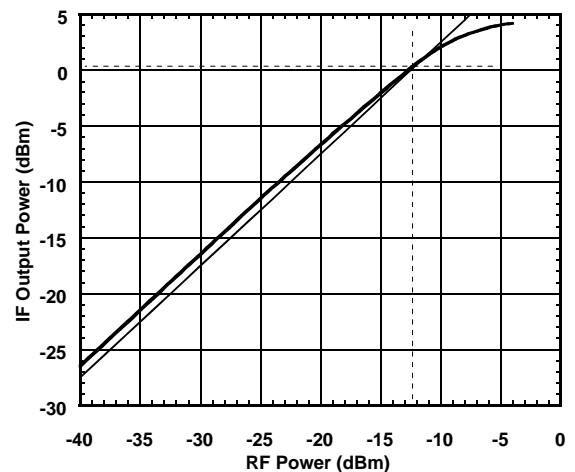

Condition

$f_{IF}=130\text{MHz}$   
 $f_{RF}=820\text{MHz}$   
 $f_{LO}=690\text{MHz}$ ,  $P_{LO}=-10\text{dBm}$   
 $V_{MIX}=V_{LO}=2.7\text{V}$



## ■ TYPICAL CHARACTERISTICS (MIXER, $f_{LO}=690\text{MHz}$ , with test circuit)

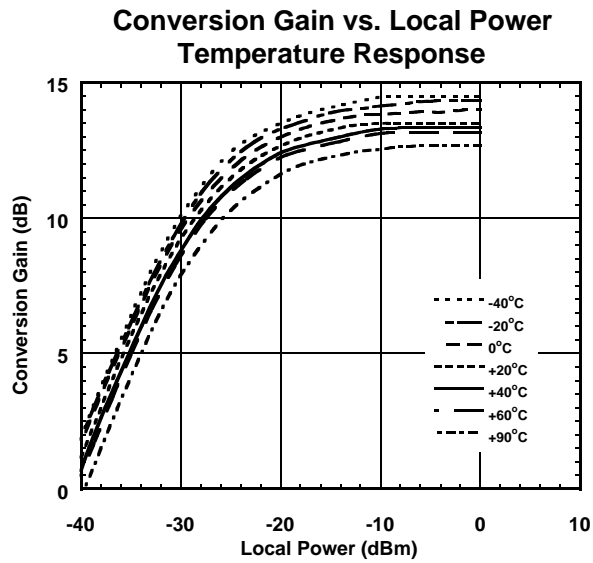

Condition  
 $f_{IF}=130\text{MHz}$   
 $f_{RF}=820\text{MHz}$ ,  $P_{RF}=-30\text{dBm}$   
 $f_{LO}=690\text{MHz}$   
 $V_{MIX}=V_{LO}=2.7\text{V}$

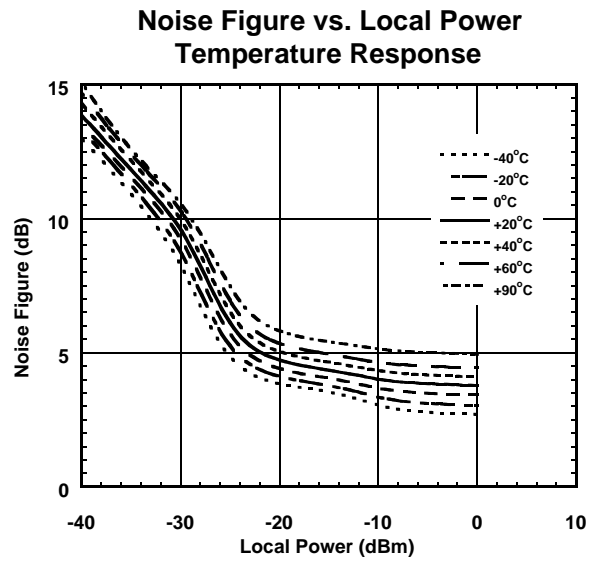

Condition  
 $f_{IF}=130\text{MHz}$   
 $f_{RF}=820\text{MHz}$   
 $f_{LO}=690\text{MHz}$   
 $V_{MIX}=V_{LO}=2.7\text{V}$

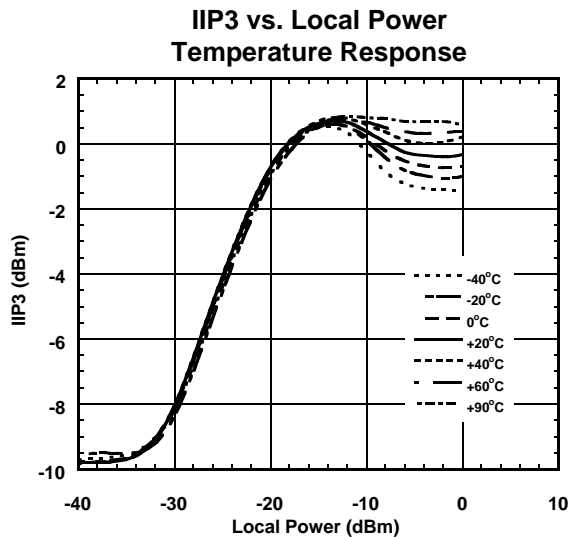

Condition  
 $f_{IF}=130\text{MHz}$   
 $f_{RF1}=820.0\text{MHz}$ ,  $P_{RF}=-30\text{dBm}$   
 $f_{RF2}=820.1\text{MHz}$   
 $f_{LO}=690\text{MHz}$   
 $V_{MIX}=V_{LO}=2.7\text{V}$

$$IIP3 = \frac{3 \times IF - IM3}{2} - G_c$$

@  $P_{RF} = -30\text{dBm}$

# NJG1704KC1

## ■ TYPICAL CHARACTERISTICS (MIXER, $f_{LO}=690\text{MHz}$ , with test circuit)

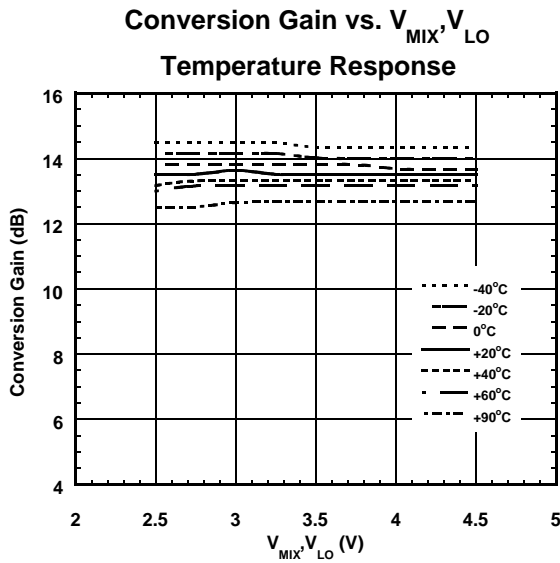

Condition  
 $f_{IF}=130\text{MHz}$   
 $f_{RF}=820\text{MHz}, P_{RF}=-30\text{dBm}$   
 $f_{LO}=690\text{MHz}, P_{LO}=-10\text{dBm}$

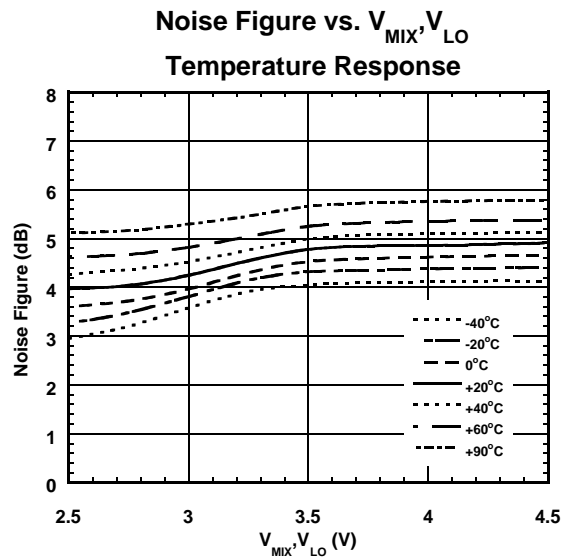

Condition  
 $f_{IF}=130\text{MHz}$   
 $f_{RF}=820\text{MHz}, P_{RF}=-30\text{dBm}$   
 $f_{LO}=690\text{MHz}, P_{LO}=-10\text{dBm}$

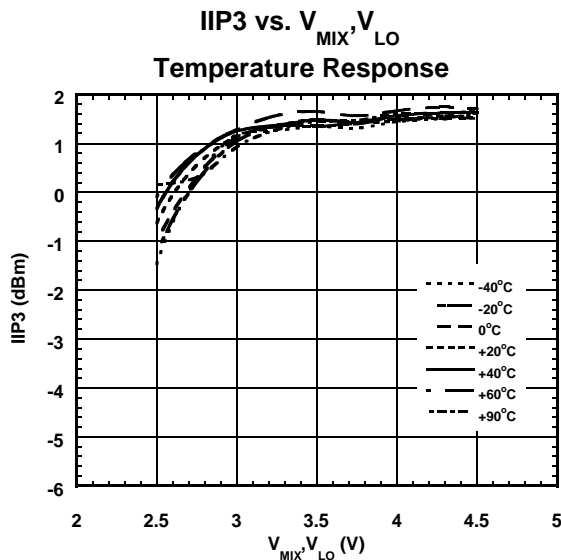

Condition  
 $f_{IF}=130\text{MHz}$   
 $f_{RF1}=820.0\text{MHz}, P_{RF}=-30\text{dBm}$   
 $f_{RF2}=820.1\text{MHz}$   
 $f_{LO}=690\text{MHz}, P_{LO}=-10\text{dBm}$

$$IIP3 = \frac{3 \times IF - IM3}{2} - G_c$$

@  $P_{RF} = -30\text{dBm}$

## ■ TYPICAL CHARACTERISTICS (MIXER, $f_{LO}=690\text{MHz}$ , with test circuit)

### MIXER IN PORT IMPEDANCE ( $P_{LO}=-10\text{dBm}$ )

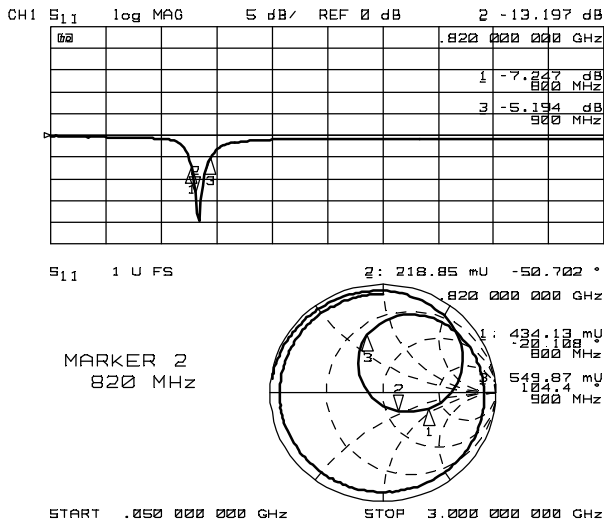

Condition  
 $V_{LNA}=0\text{V}$   
 $V_{MIX}=V_{LO}=2.7\text{V}$

### LOCAL IN PORT IMPEDANCE

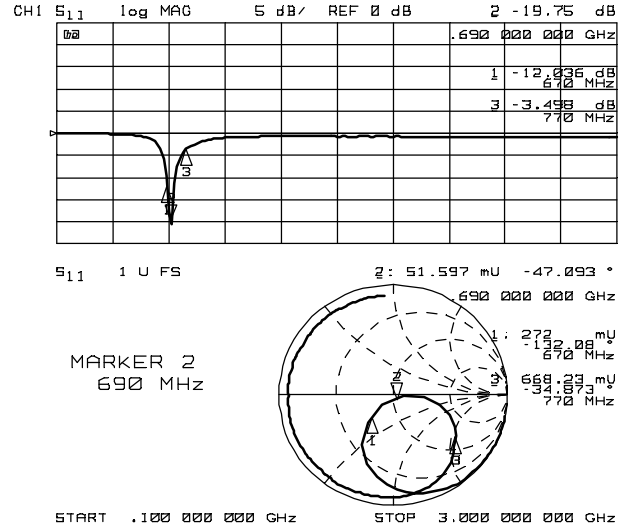

Condition  
 $V_{LNA}=0\text{V}$   
 $V_{MIX}=V_{LO}=2.7\text{V}$

### IF OUT PORT IMPEDANCE

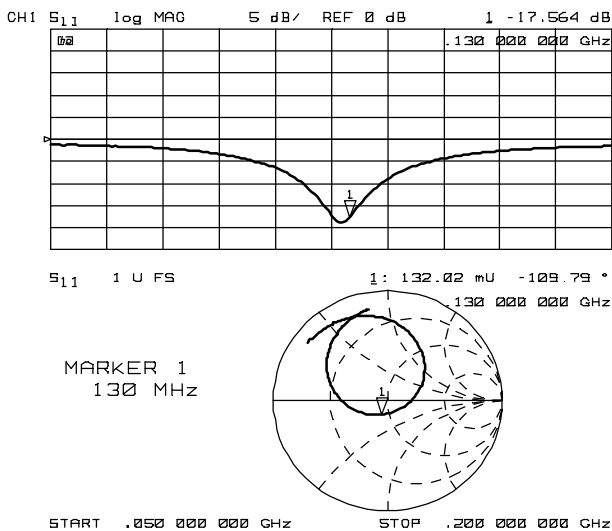

Condition  
 $V_{LNA}=0\text{V}$   
 $V_{MIX}=V_{LO}=2.7\text{V}$

# NJG1704KC1

## ■ TYPICAL CHARACTERISTICS (LNA+MIXER, $f_{LO}=690\text{MHz}$ , with test circuit)

RF IN – LOCAL IN ISOLATION  
(RF IN → LOCAL IN)

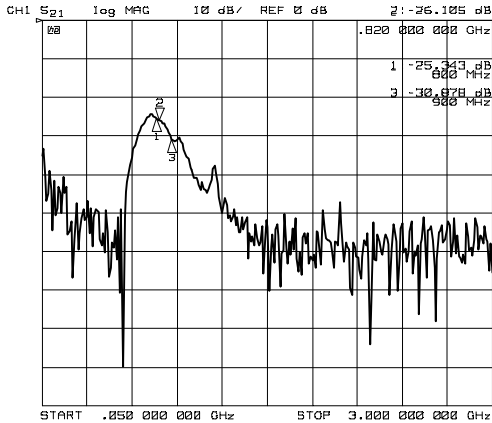

Condition  
 $V_{LNA}=2.7\text{V}$   
 $V_{MIX}=V_{LO}=2.7\text{V}$   
 Port1: RF IN  
 Port2: LOCAL IN

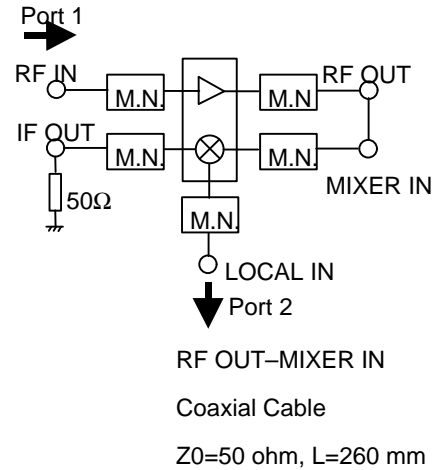

RF OUT – MIXER IN ISOLATION  
(RF OUT → MIXER IN)

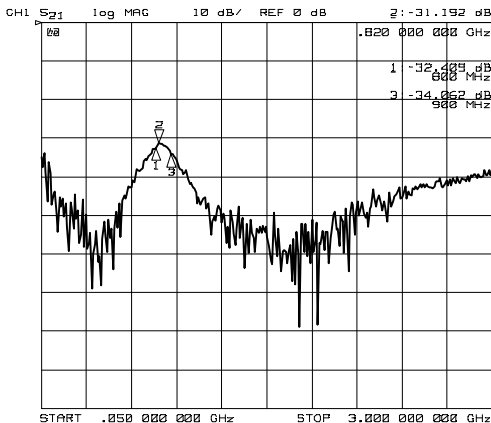

Condition  
 $V_{LNA}=2.7\text{V}$   
 $V_{MIX}=V_{LO}=2.7\text{V}$   
 Port1: RF OUT  
 Port2: MIXER IN

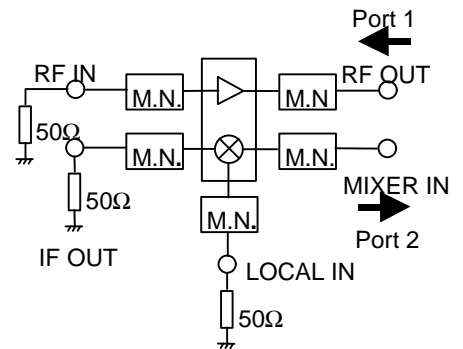

RF IN – IF OUT ISOLATION  
(RF IN → IF OUT)

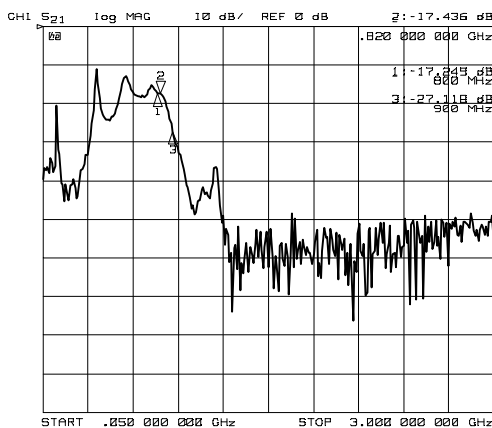

Condition  
 $V_{LNA}=2.7\text{V}$   
 $V_{MIX}=V_{LO}=2.7\text{V}$   
 Port1: RF IN  
 Port2: IF OUT

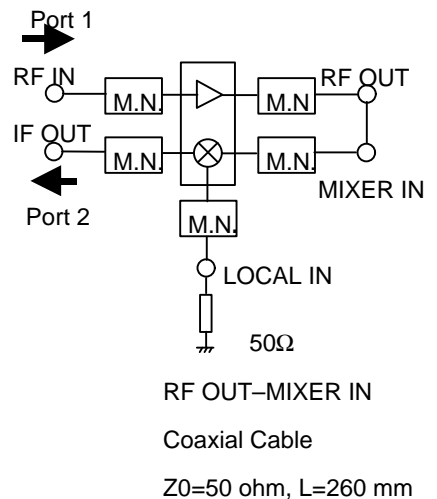

## ■ TYPICAL CHARACTERISTICS (LNA+MIXER, $f_{LO}=690\text{MHz}$ , with test circuit)

### LOCAL IN to IF OUT Isolation vs. Local Frequency

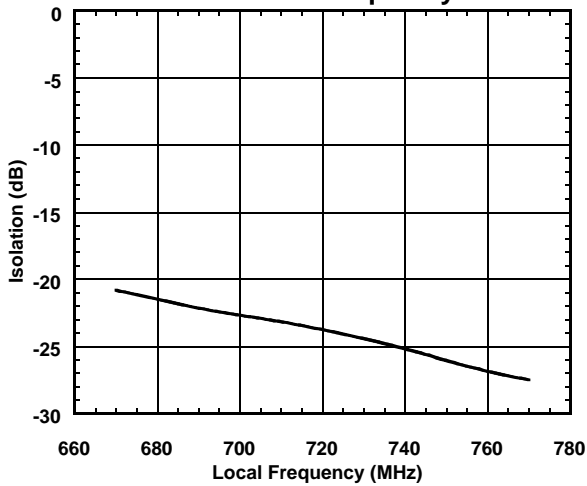

Condition

$V_{LNA}=2.7\text{V}$   
 $V_{MIX}=V_{LO}=2.7\text{V}$   
 $P_{LO}=-10\text{dBm}$   
 Port1: LOCAL IN  
 Port2: IF OUT

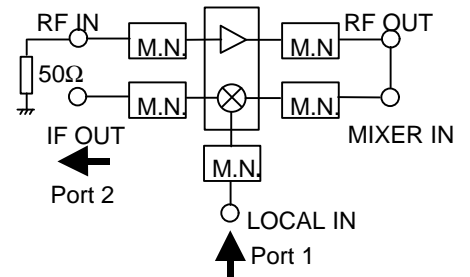

RF OUT-MIXER IN

Coaxial Cable

$Z_0=50\text{ ohm}$ ,  $L=260\text{ mm}$

### LOCAL IN to RF IN Isolation vs. Local Frequency

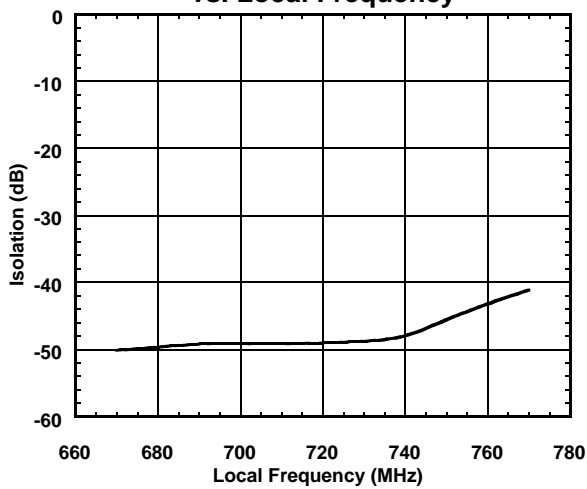

Condition

$V_{LNA}=2.7\text{V}$   
 $V_{MIX}=V_{LO}=2.7\text{V}$   
 $P_{LO}=-10\text{dBm}$   
 Port1: LOCAL IN  
 Port2: RF IN

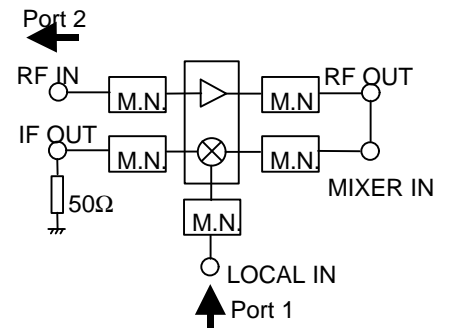

RF OUT-MIXER IN

Coaxial Cable

$Z_0=50\text{ ohm}$ ,  $L=260\text{ mm}$

# NJG1704KC1

## TEST CIRCUIT

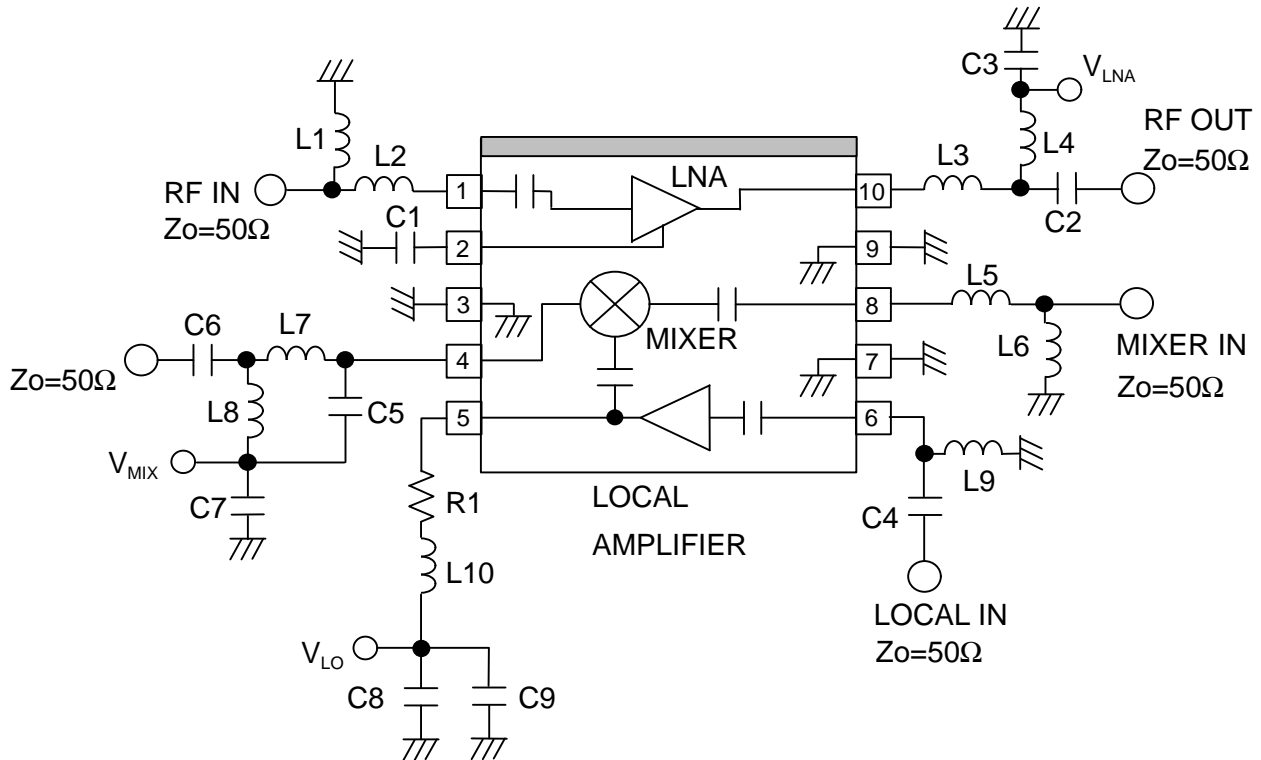

### PARTS LIST

PART ID	800MHz BAND		COMMENT
	Lower LOCAL		
	$f_{LO}=690\text{MHz}$ $f_{IF}=130\text{MHz}$		
L1	22nH		TAIYO-YUDEN (HK1005)
L2	22nH		TAIYO-YUDEN (HK1608)
L3	47nH		TAIYO-YUDEN (HK1005)
L4	18nH		TAIYO-YUDEN (HK1005)
L5	15nH		TAIYO-YUDEN (HK1005)
L6	4.7nH		TAIYO-YUDEN (HK1005)
L7	100nH		TAIYO-YUDEN (HK1608)
L8	56nH		TAIYO-YUDEN (HK1005)
L9	27nH		TAIYO-YUDEN (HK1005)
L10	39nH		TAIYO-YUDEN (HK1005)
C1	470pF		MURATA (GRM36)
C2	4pF		MURATA (GRM36)
C3	1000pF		MURATA (GRM36)
C4	1pF		MURATA (GRM36)
C5	9pF		MURATA (GRM36)
C6	1000pF		MURATA (GRM36)
C7	1000pF		MURATA (GRM36)
C8	100pF		MURATA (GRM36)
C9	1000pF		MURATA (GRM36)
R1	39Ω		1005 Size

## RECOMMENDED PCB DESIGN

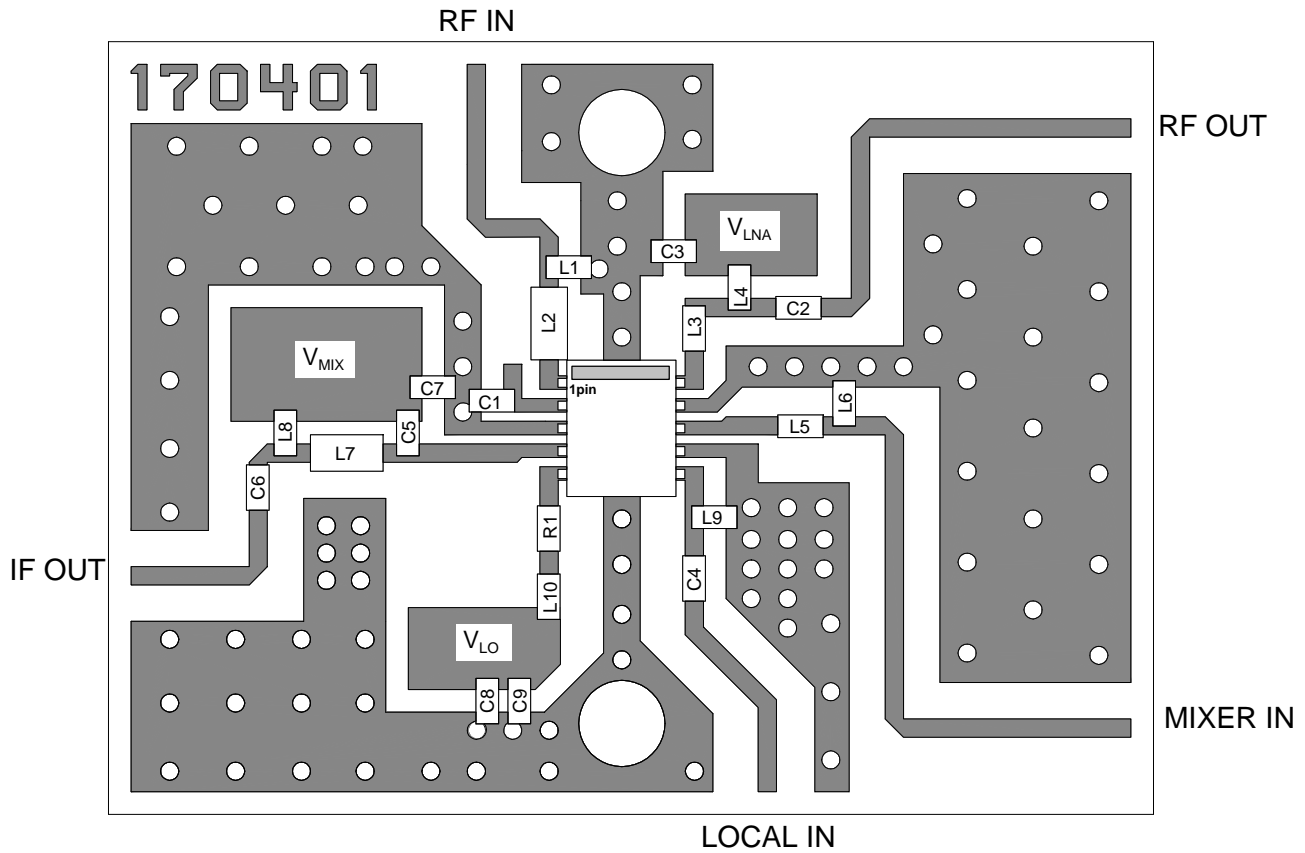

PCB (FR-4):  $t = 0.2 \text{ mm}$

MICRO STRIPLINE WIDTH =  $0.4 \text{ mm}$  ( $Z_0 = 50\Omega$ )

PCB SIZE =  $23.0 \times 17.0 \text{ mm}$

(800MHz BAND)

## MEASURING BLOCK DIAGRAM

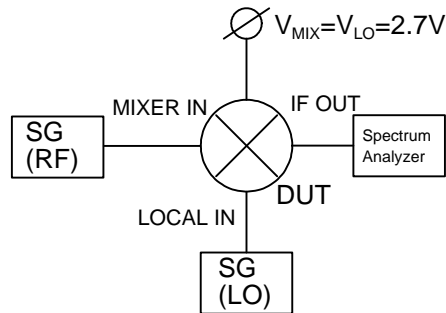

Conversion Gain Measuring Block Diagram

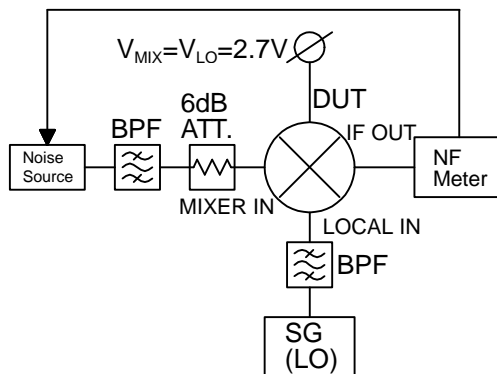

Noise Figure Measuring Block Diagram

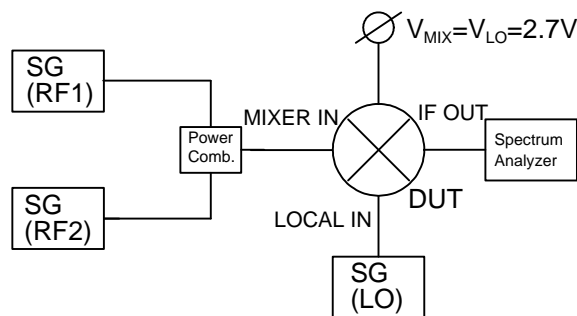

IF,IM3 Measuring Block Diagram



## PACKAGE OUTLINE (FLP10-C1)

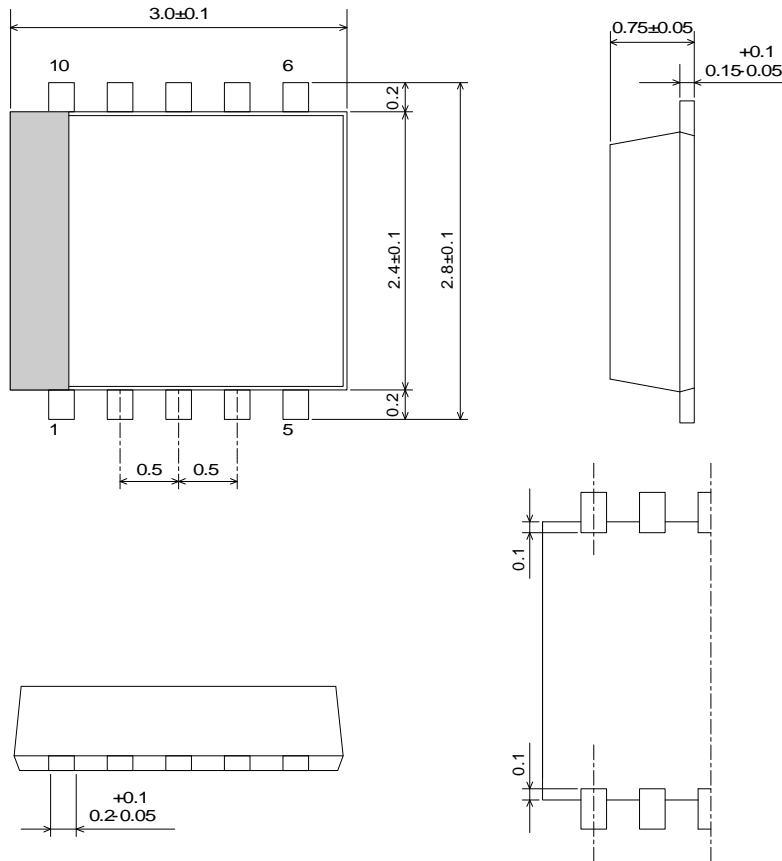

Lead material	: Copper
Lead surface finish	: Solder plating
Molding material	: Epoxy resin
UNIT	: mm
Weight	: 15mg

### Cautions on using this product

This product contains Gallium-Arsenide (GaAs) which is a harmful material.

- Do NOT eat or put into mouth.
- Do NOT dispose in fire or break up this product.
- Do NOT chemically make gas or powder with this product.
- To waste this product, please obey the relating law of your country.

### [CAUTION]

The specifications on this databook are only given for information, without any guarantee as regards either mistakes or omissions. The application circuits in this databook are described only to show representative usages of the product and not intended for the guarantee or permission of any right including the industrial rights.

This product may be damaged with electric static discharge (ESD) or spike voltage. Please handle with care to avoid these damages.



Компания «ЭлектроПласт» предлагает заключение долгосрочных отношений при поставках импортных электронных компонентов на взаимовыгодных условиях!

Наши преимущества:

- Оперативные поставки широкого спектра электронных компонентов отечественного и импортного производства напрямую от производителей и с крупнейших мировых складов;
- Поставка более 17-ти миллионов наименований электронных компонентов;
- Поставка сложных, дефицитных, либо снятых с производства позиций;
- Оперативные сроки поставки под заказ (от 5 рабочих дней);
- Экспресс доставка в любую точку России;
- Техническая поддержка проекта, помощь в подборе аналогов, поставка прототипов;
- Система менеджмента качества сертифицирована по Международному стандарту ISO 9001;
- Лицензия ФСБ на осуществление работ с использованием сведений, составляющих государственную тайну;
- Поставка специализированных компонентов (Xilinx, Altera, Analog Devices, Intersil, Interpoint, Microsemi, Aeroflex, Peregrine, Syfer, Eurofarad, Texas Instrument, Miteq, Cobham, E2V, MA-COM, Hittite, Mini-Circuits, General Dynamics и др.);

Помимо этого, одним из направлений компании «ЭлектроПласт» является направление «Источники питания». Мы предлагаем Вам помощь Конструкторского отдела:

- Подбор оптимального решения, техническое обоснование при выборе компонента;
- Подбор аналогов;
- Консультации по применению компонента;
- Поставка образцов и прототипов;
- Техническая поддержка проекта;
- Защита от снятия компонента с производства.



#### Как с нами связаться

**Телефон:** 8 (812) 309 58 32 (многоканальный)

**Факс:** 8 (812) 320-02-42

**Электронная почта:** [org@eplast1.ru](mailto:org@eplast1.ru)

**Адрес:** 198099, г. Санкт-Петербург, ул. Калинина, дом 2, корпус 4, литера А.