

Two Channel Boost LED Driver with LED Wiring Fault Detection

Features

- ▶ Switch mode controller for boost converters
- ▶ Discontinuous conduction mode of operation
- ▶ High output current accuracy
- ▶ Internal $\pm 2\%$ voltage reference ($0^\circ\text{C} < T_A < 125^\circ\text{C}$)
- ▶ Internally fixed 100kHz switching frequency
- ▶ Hiccup mode protection for both short circuit and open circuit conditions
- ▶ LED wiring fault detection to detect short cathode to ground condition

Applications

- ▶ DC/DC LED driver applications
- ▶ RGB or white LED backlight applications
- ▶ Flat panel display backlighting

General Description

The HV9880 is a current mode control LED driver IC designed to control two boost LED drivers in constant frequency mode. The controller uses a peak current-mode control scheme and includes internal transconductance amplifiers to accurately control the output currents over all line and load conditions. The IC also provides disconnect switch gate drivers, which can be used to achieve good PWM rise and fall times for the LED currents using external disconnect FETs.

HV9880 also provides two, independent TTL compatible, low-frequency PWM dimming inputs which can accept external control signals with a duty ratio of 0-100% and a frequency of up to a few kilohertz.

HV9880 includes a wiring fault detection function that sends a flag to the boost input power supply in case of an LED wiring fault.

Typical Application Circuit

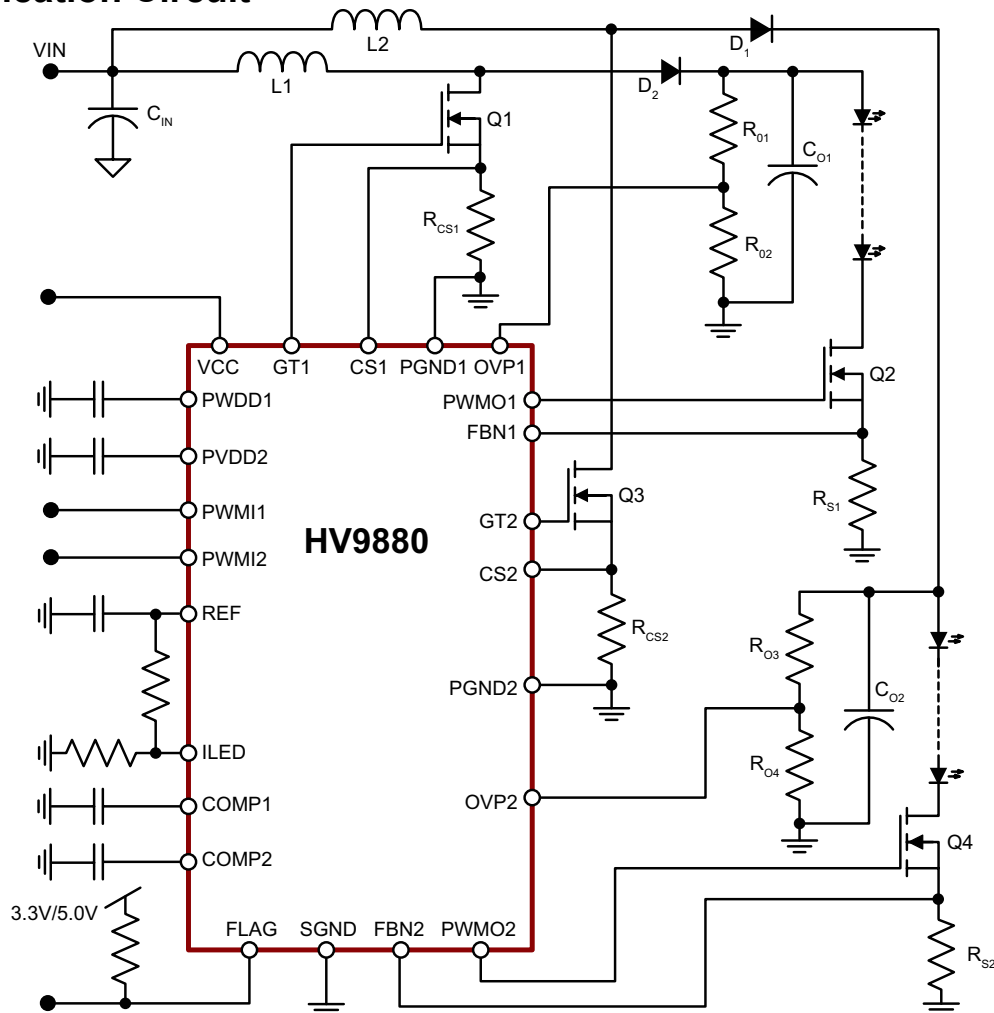

Ordering Information

Device	Package Option
	24-Lead SOW 15.40x7.50mm body 2.65mm height (max) 1.27mm pitch
HV9880	HV9880WG-G

-G indicates package is RoHS compliant ('Green')



Absolute Maximum Ratings

Parameter	Value
VCC to GND	-0.5V to +45V
PVDD1,2 to GND	-0.5V to +13V
GT1,2, PWM01,2 to GND	-0.3V to (PV _{DD} + 0.3V)
REF to GND	-0.3V to +6.0V
All other pins to GND	-0.3V to (REF + 0.3V)
Continuous power dissipation (T _A = +25°C) 24-Lead SOW	1300mW
Junction temperature	+150°C
Storage temperature range	-65°C to +150°C

Stresses beyond those listed under "Absolute Maximum Ratings" may cause permanent damage to the device. These are stress ratings only, and functional operation of the device at these or any other conditions beyond those indicated in the operational sections of the specifications is not implied. Exposure to absolute maximum rating conditions for extended periods may affect device reliability.

Thermal Resistance

Package	θ_{ja}
24-Lead SOW (WG)	60°C/W

Pin Configuration

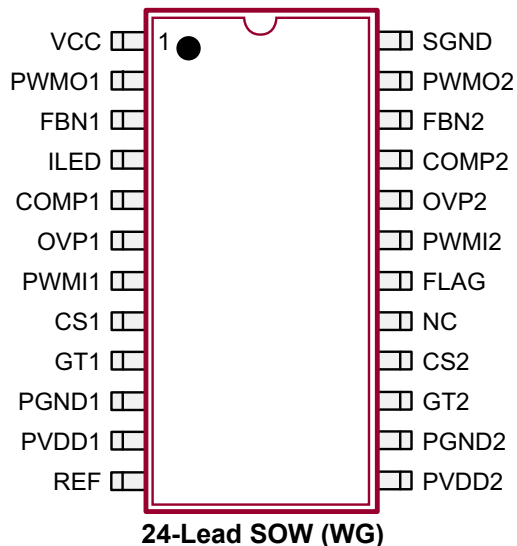

Product Marking

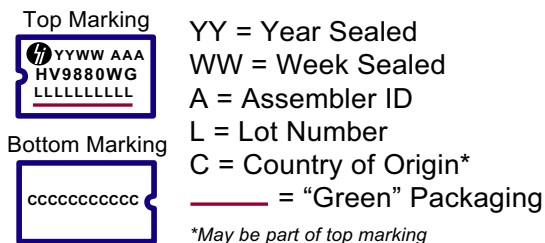

Package may or may not include the following marks: Si or

24-Lead SOW (WG)

Electrical Characteristics

(The * denotes the specifications which apply over the full operating ambient temperature range of $0^{\circ}\text{C} < T_A < +125^{\circ}\text{C}$, otherwise the specifications are at $T_A = 25^{\circ}\text{C}$. $V_{CC} = 12\text{V}$, $C_{DD1,2} = 1.0\mu\text{F}$, $C_R = 0.1\mu\text{F}$, $C_{GT1,2} = 1\text{nF}$, $C_{PWMO1,2} = 500\text{pF}$, $\text{PWMI}_{1,2} = \text{REF}$ unless otherwise noted.)

Sym	Description	Min	Typ	Max	Unit	Conditions
-----	-------------	-----	-----	-----	------	------------

Input

V_{CC}	Input DC supply voltage range	*	10.0	-	40.0	V	DC input voltage
I_{INSD}	Shut-down mode supply current	-	-	-	1.5	mA	PWMI1 = PWMI2 = GND

Internal Regulator (PVDD1, PVDD2)

VDD	Internally regulated voltage	*	9.5	10.0	10.5	V	$V_{CC} = 10.0 - 40.0\text{V}$, $\text{PWMI}_{1,2} = \text{REF}$
$\text{UVLO}_{\text{RISE}}$	VDD under voltage lockout threshold	*	8.0	-	9.0	V	VDD _{1,2} rising
$\text{UVLO}_{\text{HYST}}$	VDD under voltage lockout hysteresis	-	-	500	-	mV	VDD _{1,2} falling

Reference Voltage

REF	Internally regulated voltage	*	4.9	5.0	5.1	V	$\text{PWMI}_{1,2} = \text{REF}$; $I_{\text{REF EXT}} = 0 - 500\mu\text{A}$
$\text{UVLO}_{\text{RISE1}}$	REF under voltage lockout threshold	*	4.2	-	4.8	V	REF rising
$\text{UVLO}_{\text{HYST1}}$	REF under voltage hysteresis	#	-	200	-	mV	REF falling

PWM Dimming (PWMI1, PWMI2)

$V_{\text{PWM(LO)}}$	PWMD input low voltage	*	-	-	0.8	V	---
$V_{\text{PWM(HI)}}$	PWMD input high voltage	*	2.3	-	-	V	---
R_{PWMI}	Internal pull down resistance at PWMD	-	50	100	150	k Ω	$\text{PWMI}_{1,2} = 3.3\text{V}$

Boost FET Driver (GT1, GT2)

I_{SOURCE}	GATE short circuit current, sourcing	*	0.2	-	-	A	$V_{\text{GATE}} = 0\text{V}$ PVDD1 = PVDD2 = 10V
I_{SINK}	GATE sinking current	*	0.3	-	-	A	$V_{\text{GATE}} = 10\text{V}$ PVDD1 = PVDD2 = 10V
T_{RISE}	GATE output rise time	-	-	-	100	ns	---
T_{FALL}	GATE output fall time	-	-	-	70	ns	---
D_{MAX}	Maximum duty cycle at GATE output	*	88	-	94	%	---

Disconnect FET Driver (PWMO1, PWMO2)

$I_{\text{SOURCE,PWMO}}$	GATE short circuit current, sourcing	*	0.02	-	-	A	$V_{\text{PWMO}} = 0\text{V}$
$I_{\text{SINK,PWMO}}$	GATE sinking current	*	0.04	-	-	A	$V_{\text{PWMO}} = 10\text{V}$
$T_{\text{RISE,PWMO}}$	GATE output rise time	-	-	-	250	ns	---
$T_{\text{FALL,PWMO}}$	GATE output fall time	-	-	-	150	ns	---

Oscillator

f_{Osc}	Oscillator frequency	*	85	100	115	kHz	---
$\text{Phase}_{\text{Osc}}$	Phase difference between the clocks	#	-	180	-	deg	---

Notes:

- * Denotes specifications guaranteed by design and characterization over the full operating ambient temperature range of $0^{\circ}\text{C} < T_A < +125^{\circ}\text{C}$.
- # Denotes specifications which are guaranteed by design.

Electrical Characteristics (cont.)

Sym	Description	Min	Typ	Max	Unit	Conditions
-----	-------------	-----	-----	-----	------	------------

Current Sense (CS1, CS2)

T_{BLANK}	Leading edge blanking	*	100	-	250	ns	---
T_{PROP_DELAY1}	Delay to GATE	-	-	-	200	ns	COMP _{1,2} = REF ; 50mV overdrive at CS _{1,2}
R_{DIV}	Internal resistor divider ratio (COMP to CS)	#	-	0.083	-	-	---
V_{OFFSET}	Comparator offset voltage	#	-10	-	10	mV	---

Over Voltage Protection (OVP1, OVP2)

$V_{OVP,RISING}$	Over voltage rising trip point	*	1.95	2.05	2.15	V	OVP rising
$V_{OVP,HYST}$	Over voltage hysteresis	-	-	0.20	-	V	OVP falling

Internal Transconductance Opamp

GB	Gain-bandwidth product	#	-	1.0	-	MHz	75pF capacitance at COMP pin
A_V	Open loop DC gain	-	60	-	-	dB	Output open
V_{CM}	Input common-mode range	#	-0.3	-	1.5	V	---
V_O	Output voltage range	#	0.7	-	REF-0.7	V	$A_V > 60\text{dB}$
G_M	Transconductance	-	500	720	900	$\mu\text{A/V}$	---
V_{OFFSET}	Input offset voltage	*	-3.0	-	+3.0	mV	---
I_{BIAS}	Input bias current	#	-	0.5	1.0	nA	---
$I_{COMP,DIS}$	Discharging current	-	1.0	-	-	mA	$V_{COMP} = 5.0\text{V}$

Over Current Protection

$T_{BLANK,OCP}$	Blanking time for OCP	*	500	-	900	ns	---
G_{SC}	Gain for short circuit comparator	-	1.8	2.0	2.2	-	---
V_{OMIN}	Minimum output voltage of the gain stage	*	0.14	0.20	0.30	V	I _{LED} = GND
T_{OFF}	Propagation time to PWMO and GATE for short circuit detection	-	-	-	300	ns	PWMI = REF; I _{LED} = 400mV; FBN step from 0 to 900mV; PWMO goes from high to low; no capacitance at PWMO pin
T_{HCP}	Internal hiccup time	#	2.22	2.56	2.91	ms	---

Short Cathode Detect (PWMD_{1,2} high)

V_{REF1}	COMP over-voltage threshold	*	4.6	-	-	V	REF = 5.0V
V_{REF2}	FB under-voltage threshold	*	0.10	-	0.20	V	---
$I_{SINK,FLAG}$	Sink current into FLAG pin	-	1.0	-	-	mA	FLAG = 0.5V
T_{DET}	Delay time to FLAG low	#	35.61	40.96	48.19	ms	---

Notes:

* Denotes specifications guaranteed by design and characterization over the full operating ambient temperature range of $0^{\circ}\text{C} < T_A < +125^{\circ}\text{C}$.

Denotes specifications which are guaranteed by design.

Power-On Sequence

For the IC to work as intended, the following power-on sequence is critical.

1. VCC to the IC
2. 3.3 or 5.0V to the pull-up resistor at FLAG
3. PWM must be delayed with respect to VCC.

Note that 1 and 2 can be interchanged but item 3 should always occur after items 1 and 2.

Functional Block Diagram

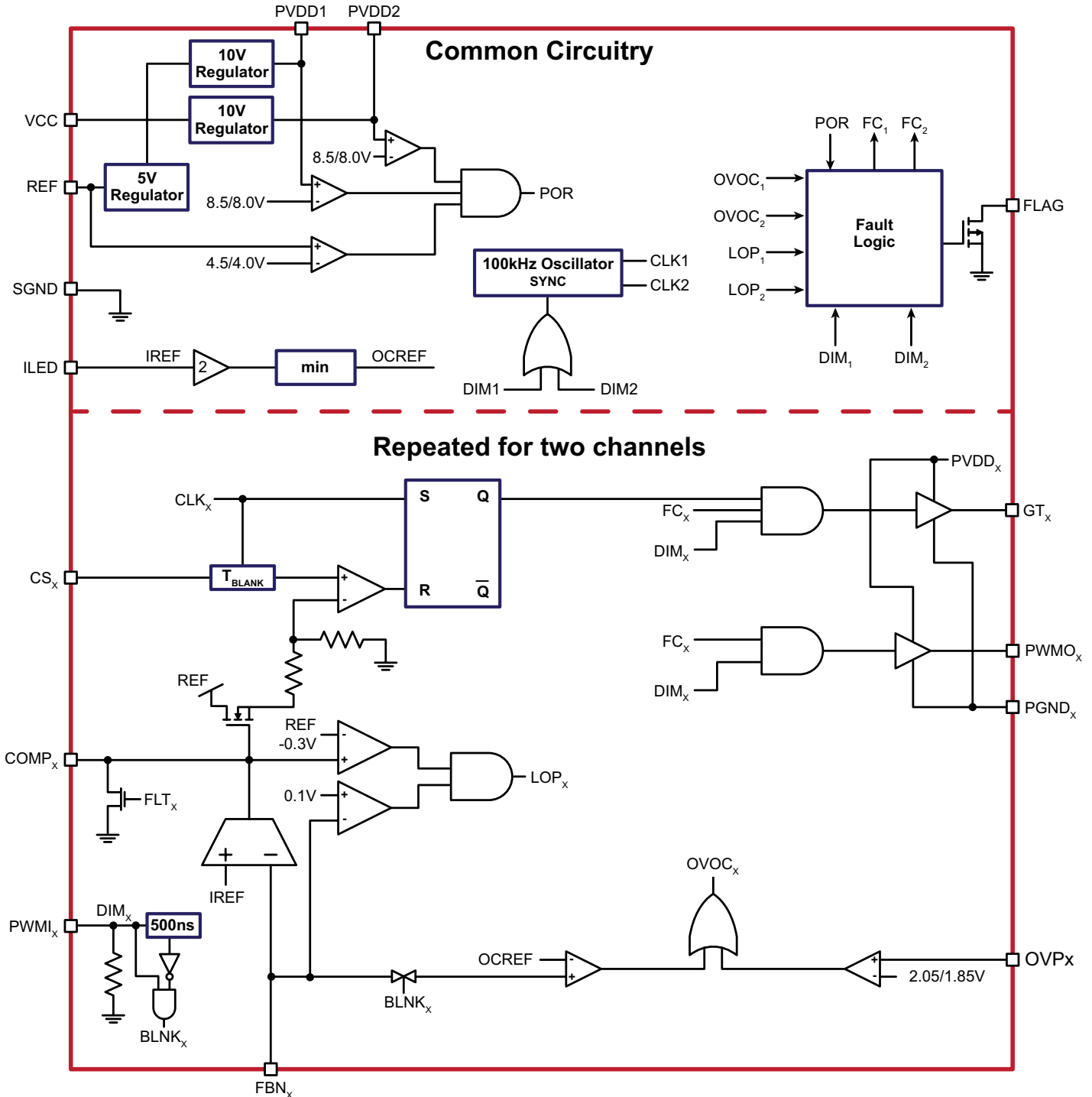

Power Topology

The HV9880 is a switch-mode LED driver designed to control two boost converters in a constant frequency mode. The IC includes internal linear regulators which enables it to operate at input voltages from 10V to 40V. The IC includes features typically required in LED drivers like open LED protection, output short circuit protection, linear and PWM dimming and accurate control of the LED current.

The IC also includes an open LED current feedback loop detection which is used to detect a short cathode to ground fault. Upon detection of the fault, the IC shuts down and signals the boost power supply to shutdown by pulling the FLAG pin low. The IC is restarted by cycling the power to the IC.

Power Supply to the IC (VCC, PVDD1-2 and REF)

The HV9880 can be powered directly from its VCC pin that takes a voltage up to 40V. There are three linear regulators within the HV9880 – two 10V linear regulators (PVDD1, PVDD2) which are used for the FET drivers and a 5.0V linear regulator (REF) which supplies power to the rest of the control logic. The IC also has a built in under-voltage lockout which shuts off the IC if the voltage at either PVDD or the REF pins fall below the corresponding UVLO threshold.

Both PVDD and REF pins must be bypassed by a low ESR capacitor ($\geq 0.1\mu\text{F}$) for proper operation.

The input current drawn from the external power supply (or VCC pin) is a sum of the 1.5mA (max) current drawn by the all the internal circuitry and the current drawn by the gate drivers (which in turn depends on the switching frequency, PWM dimming frequency and the gate charge of the external FETs).

$$I_{IN} = 1.0\text{mA} + (Q_{G1} + Q_{G3}) \cdot f_S + (Q_{G2} + Q_{G4}) \cdot f_{PWM}$$

In the above equation, f_S is the switching frequency of the converter, f_{PWM} is the frequency of the applied PWM dimming signal, Q_{G1} and Q_{G3} are the gate charges of the external boost FETs and Q_{G2} and Q_{G4} are the gate charges of the disconnect FETs (all of which can be obtained from the FET datasheets).

The REF pin can also be used as a reference voltage to set the LED current using a resistor divider to the FBP pin. The REF pin can also be used to as the voltage for the pull-up resistor at the FLAG pin as long as the total external current draw from the REF pin does not exceed 0.5mA.

Clock

The HV9880 includes an internal 200kHz clock which is synchronized to the rising edge of either PWM1 or PWM2. This

clock is then divided by two to produce two 100kHz clocks which are 180 degrees apart. These 100kHz clocks are used to set the switching frequencies of the two converters.

Current Sense (CS)

The current sense input is used to sense the source current of the switching FET. The CS inputs of the HV9880 include a built in 100ns (minimum) blanking time to prevent spurious turn off due to the initial current spike when the FET turns on.

The IC includes internal resistor divider networks, which steps down the voltage at the COMP pins by a factor of 12 (11R:1R). These voltages are used as the reference for the current sense comparators. Since the maximum voltage of the COMP pin is REF-1.0V, this voltage determines the maximum reference current for the current sense comparator and thus the maximum inductor current.

The current sense resistor R_{CS} should be chosen so that the input inductor current is limited to below the saturation current level of the input inductor. For discontinuous conduction mode of operation, no slope compensation is necessary. In this case, the current sense resistor is chosen as:

$$R_{CS} = \frac{V_{DD} - 1.0V}{12 \cdot I_{SAT}}$$

where I_{SAT} is the saturation current of the inductor.

Note: COMP voltage lower than 1.0V will produce no gate pulses at GT pin.

PWMO Outputs

The PWMO pins are used to drive disconnect FETs while driving boost converters. These FETs disconnect the output filter capacitors from the LED loads during PWM dimming and enable a high PWM dimming ratio.

Control of the LED Current (ILED, FBN1-2 and COMP1-2)

The LED current in the HV9880 is controlled in a closed-loop manner. The voltage reference at FBP which sets the LED current is set by using a resistor divider from the REF pin (or can be set externally with a low voltage source). This reference voltage is compared to the voltage at the FBN pin which senses the LED current by using a current sense resistor. The HV9880 includes a 1.0MHz transconductance amplifier with tri-state output, which is used to close the feedback loops and provide accurate current control. The compensation network is connected at the COMP pin.

The output of the op-amp is buffered and connected to the current sense comparator using an 11R:1R resistor divider.

The output of the op-amp is also controlled by the signal ap-

plied to the PWMI pin. When PWMI is high, the output of the op-amp is connected to the COMP pin. When PWMI is low, the output is left open. This enables the integrating capacitor to hold the charge when the PWMI signal has turned off the gate drive. When the IC is enabled, the voltage on the integrating capacitor will force the converter into steady state almost instantaneously.

Linear Dimming (ILED)

Linear dimming can be accomplished in the HV9880 by varying the voltage at the ILED pin. Note that since the HV9880 is a peak current mode controller, it has a minimum on-time for the GATE output. This minimum on-time will prevent the converter from turning off completely even when the IREF pin is pulled to GND. Thus, linear dimming cannot accomplish true zero LED current. To get zero LED current PWM dimming has to be used.

Due to the offset voltage of the short circuit comparator as well as the non-linearity of the X2 gain stage, pulling the FBP pin very close to GND might cause the internal short circuit comparator to trigger and shut down the IC. To overcome this, the output of the gain stage is limited to 140mV (minimum), allowing the IREF pin to be pulled all the way to 0V without triggering the short circuit comparator.

PWM Dimming (PWMI1-2)

PWM dimming in the HV9880 can be accomplished using a TTL compatible square wave source at the PWMD pin.

Fault Conditions

The HV9880 is a robust controller which can protect the LEDs and the LED driver in case of fault conditions. The HV9880 protects the system from three different fault conditions.

- Open circuit fault
- Short circuit fault (short across the LED string)
- Open Loop fault (LED string to ground fault)

Open Circuit Fault

The HV9880 provides hysteretic over voltage protection to protect the system from dangerous over voltages in case of an open LED condition.

When the load is disconnected in a boost or flyback converter, the output voltage rises as the output capacitor starts charging. When the output voltage reaches the OVP rising threshold, the HV9880 detects an over voltage condition and turns off the converter (GATE and PWMO outputs are disabled and COMP is pulled to ground). The converter is turned back on only when the output voltage falls below the falling OVP threshold (which is 8% lower than the rising threshold). This time is mostly dictated by the R-C time constant of the output capacitor C_O and the resistor network

used to sense over voltage ($R_{O1} + R_{O2}$). In case of a persistent open circuit condition, this cycle keeps repeating maintaining the output voltage within an 8% band. Note that the hiccup time between restart attempts is dependent entirely on the R-C time constant and the OVP resistor divider must be chosen accordingly.

In most designs, the lower threshold voltage of the over voltage protection ($V_{OVP} - 8\%$) at which point the HV9880 attempts to restart will be more than the steady state LED string voltage. Thus, when the LED load is reconnected to the output of the converter, the voltage differential between the actual output voltage and the LED string voltage will cause a spike in the output current. This causes a short circuit to be detected and the HV9880 will trigger short circuit protection. This behavior continues till the output voltage becomes lower than the LED string voltage at which point, no fault will be detected and normal operation of the circuit will commence.

Short Circuit Fault

When a short circuit condition is detected (output current becomes higher than twice the steady state current), the GATE and PWMO outputs are pulled low, and COMP is pulled to ground. As soon as the disconnect FET is turned off, the output current goes to zero and the short circuit condition disappears. At this time, the internal 8-bit hiccup timer starts counting. Once the counter reaches 256, the converter attempts to restart. If the fault condition still persists, the converter shuts down and goes through the cycle again. If the fault condition is cleared (due to a momentary output short) the converter will start regulating the output current normally. This allows the LED driver to recover from accidental shorts without having to reset the IC.

Note that the power rating of the LED sense resistor has to be chosen properly if it has to survive a persistent fault condition. The power rating can be determined using:

$$P_{RS} = \frac{I_{SAT}^2 \cdot R_S \cdot (T_{FAULT} + T_{OFF})}{t_{HICCUP}}$$

where I_{SAT} is the saturation current of the disconnect FET. In case of the HV9880, ($T_{FAULT} = T_{OFF}$) is 350ns(max). The worst case hiccup time is $256 \cdot T_{S(MIN)} = 2.23ms$.

During PWM dimming, the parasitic capacitance of the LED string might cause a spike in the output current when the disconnect FET is turned on. If this spike is detected by the short circuit comparator, it will cause the IC to detect an over current condition falsely and shut down.

In the HV9880, to prevent these false triggerings, there is a built in 500ns (min) blanking network for the short circuit

comparator. This blanking network is activated when the PWM input goes high. Thus, the short circuit comparator will not see the spike in the LED current during the PWM dimming turn-on transition. Once the blanking timer is completed, the short circuit comparator will start monitoring the output current. Thus, the total delay time for detecting a short circuit will depend on the condition of the PWM input. If the output short circuit exists before the PWM dimming signal goes high, the total detection time will be:

$$t_{DETECT1} = t_{BLANK} + t_{DELAY} \approx 1150ns(max)$$

If the short circuit occurs when the PWM dimming signal is already high, the time to detect will be:

$$t_{DETECT1} = t_{DELAY} \approx 250ns(max)$$

Open Loop Fault

Open Loop Fault occurs when the any part of the LED string is shorted to ground, bypassing the LED current sense resistor. In this case, there is no direct feedback of the output current since the current sense resistor is bypassed.

Consider a case of three LED light bars connected in series and driven from an LED driver. Assume that the input to the boost converter is 120V, and that each LED light bar has a forward drop of about 80V (25 LEDs with 3.2V/per LED). If one of connections between the LED light bars is shorted to ground (see Fig.1), then excessive current might flow through the LEDs.

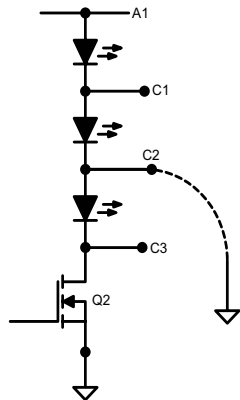

Fig.1 : Short Cathode Fault

This situation needs to be detected and prevented. Note that turning off the boost converter might not be sufficient in all cases. For example, if C1 was shorted in ground in Fig.1, the LED string voltage (one string: 80V) is lower than the input voltage (120V), and turning the boost converter off will not prevent the short circuit current. Hence, in addition to turning off the boost converter, the solution is to signal the input 120V power supply to turn off. This is achieved by means of the FLAG output (see typical application circuit).

In the HV9880, a short cathode condition is detected by sensing the voltages at FBN and COMP pins when PWMI = HI.

If the short circuit to ground occurs at nodes A1 or C1, then the over current condition will be detected by the converter's power supply since its output is effectively shorted to ground. Short cathode detection is needed only when the fault occurs at either C2 or C3 nodes.

When a short to ground occurs at C2 or C3, then the LED current is diverted away from the current sense resistor R_{CS} and flows directly to ground. Since the current through $R_{CS} = 0$, the FBN voltage becomes zero. This causes the output of the transconductance amplifier to rail to its maximum output. The combination of $FBN < 0.1V$ and $COMP > 4.7V$ is used to detect the short cathode fault.

When the short cathode fault is detected, an internal 12-bit counter is started. When the counter reaches 4096, the IC is turned off and FLAG is pulled low. The counter is reset if the fault disappears during this time.

Short Cathode Detection

There are two cases to consider when for short cathode protection. (Note that only a short circuit to ground at C2 or C3 is considered).

Case 1: Short cathode condition exists prior to the boost converter being powered on.

In this case, since the input voltage is lower than the LED string voltage, when the boost power is applied, no current flows through the LEDs and nothing happens. When the IC is turned on by applying a PWM signal, then the IC tries to regulate the LED current. Since the LED current sense resistor is bypassed, FBN pin will be ground and COMP will rail to REF. After the internal timer completes counting to 40ms, the IC will shut down and pull down the FLAG pin to indicate a fault condition to the boost converter.

Case 2: Short cathode condition occurs during normal operation.

In this case, when the short occurs, FBN will drop to zero and COMP will ramp up to REF. At this point, the internal timer starts and after 40ms, the IC shuts down and the FLAG pin is pulled low.

Reset of the Fault Condition

The IC can be reset by recycling the power to the IC.

Pin Description

Pin #	Pin Name	Description
1	VCC	Input power supply pin.
2	PWMO1	Pin drives the external disconnect FETs.
3	FBN1	LED current feedback input.
4	ILED	LED current feedback reference voltage input. LED current can be set using a resistor divider into this pin from the REF pin.
5	COMP1	LED current error amplifier output. A compensation network is required at this pin for loop stability.
6	OVP1	Pin to detect over-voltage conditions.
7	PWMI1	TTL compatible square wave signals can be applied to this pin to PWM dim the corresponding LED strings.
8	CS1	This pin is used to sense the source current of the external power FETs.
9	GT1	GATE driver output for the switching FETs.
10	PGND1	Ground return for all gate driver currents. This pin must be connected to the return path from the input.
11	PVDD1	Pins is the output of the high voltage linear regulators and powers the gate drivers.
12	REF	Pin provides the power supply for the analog circuitry within the IC as well as providing a reference which can be used to set the LED current.
13	PVDD2	This pin is the outputs of the high voltage linear regulators and power the gate drivers.
14	PGND2	Ground return for all gate driver currents. This pin must be connected to the return path from the input.
15	GT2	GATE driver output for the switching FETs.
16	CS2	Pins is used to sense the source current of the external power FETs.
17	NC	No Connect Pin. This pin should be left floating.
18	FLAG	This is an open-drain, active-low output which indicates a short-cathode fault condition.
19	PWMI2	TTL compatible square wave signals can be applied to this pin to PWM dim the corresponding LED strings.
20	OVP2	Pins used to detect over voltage conditions.
21	COMP2	LED current error amplifier output. A compensation network is required at this pin for loop stability.
22	FBN2	LED current feedback input
23	PWMO2	Pin drives the external disconnect FETs
24	SGND	Ground return for all the low power analog internal circuitry. This pin must be connected to the return path from the input.

24-Lead SOW (Wide Body) Package Outline (WG)

15.40x7.50 body, 2.65mm height (max), 1.27mm pitch

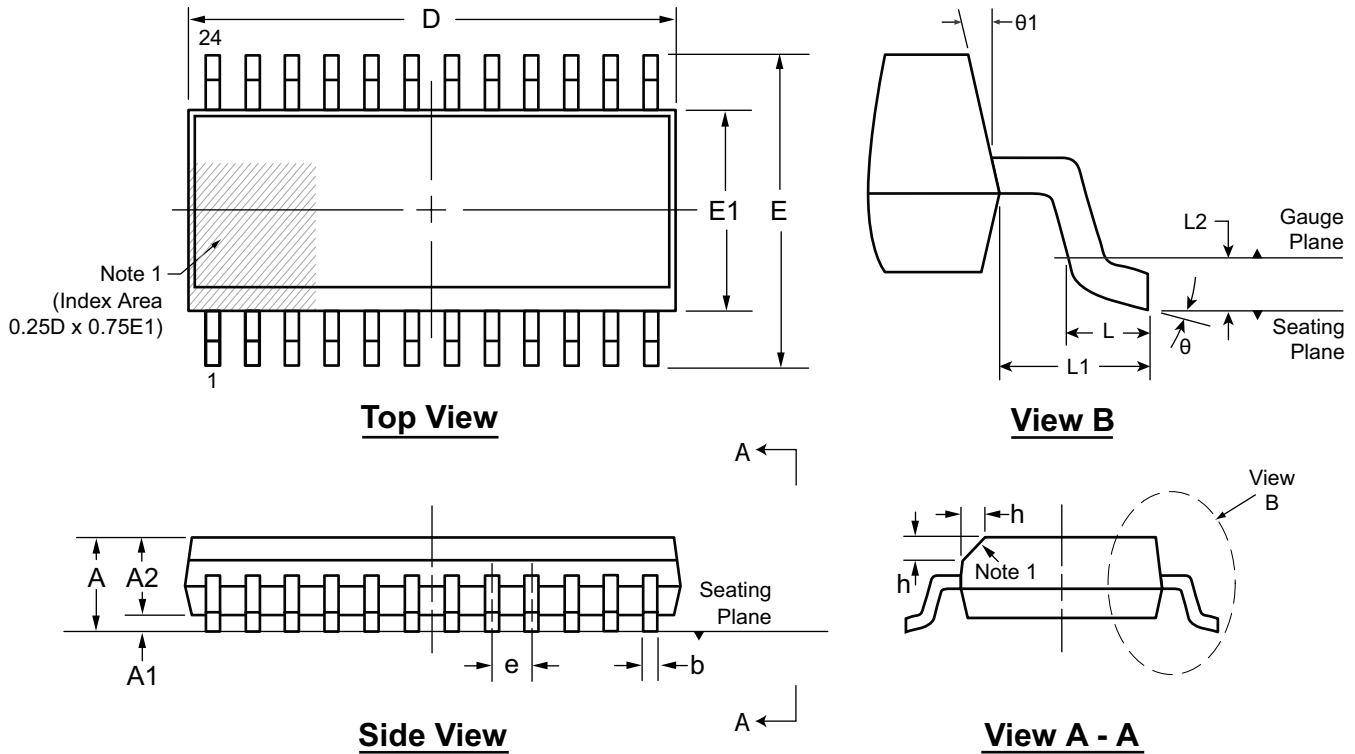

Note:
 1. A Pin 1 identifier must be located in the index area indicated. The Pin 1 identifier can be: a molded mark/identifier; an embedded metal marker; or a printed indicator.

Symbol		A	A1	A2	b	D	E	E1	e	h	L	L1	L2	θ	θ1
Dimension (mm)	MIN	2.15*	0.10	2.05	0.31	15.20*	9.97*	7.40*	1.27 BSC	0.25	0.40	1.40 REF	0.25 BSC	0°	5°
	NOM	-	-	-	-	15.40	10.30	7.50		-	-			-	-
	MAX	2.65	0.30	2.55*	0.51	15.60*	10.63*	7.60*		0.75	1.27			8°	15°

JEDEC Registration MS-013, Variation AD, Issue E, Sep. 2005.

* This dimension is not specified in the JEDEC drawing.

Drawings are not to scale.

Supertex Doc. #: DSPD-24SOWWG, Version E041309.

(The package drawing(s) in this data sheet may not reflect the most current specifications. For the latest package outline information go to <http://www.supertex.com/packaging.html>.)

Supertex inc. does not recommend the use of its products in life support applications, and will not knowingly sell them for use in such applications unless it receives an adequate "product liability indemnification insurance agreement." Supertex inc. does not assume responsibility for use of devices described, and limits its liability to the replacement of the devices determined defective due to workmanship. No responsibility is assumed for possible omissions and inaccuracies. Circuitry and specifications are subject to change without notice. For the latest product specifications refer to the Supertex inc. (website: <http://www.supertex.com>)



Компания «ЭлектроПласт» предлагает заключение долгосрочных отношений при поставках импортных электронных компонентов на взаимовыгодных условиях!

Наши преимущества:

- Оперативные поставки широкого спектра электронных компонентов отечественного и импортного производства напрямую от производителей и с крупнейших мировых складов;
- Поставка более 17-ти миллионов наименований электронных компонентов;
- Поставка сложных, дефицитных, либо снятых с производства позиций;
- Оперативные сроки поставки под заказ (от 5 рабочих дней);
- Экспресс доставка в любую точку России;
- Техническая поддержка проекта, помощь в подборе аналогов, поставка прототипов;
- Система менеджмента качества сертифицирована по Международному стандарту ISO 9001;
- Лицензия ФСБ на осуществление работ с использованием сведений, составляющих государственную тайну;
- Поставка специализированных компонентов (Xilinx, Altera, Analog Devices, Intersil, Interpoint, Microsemi, Aeroflex, Peregrine, Syfer, Eurofarad, Texas Instrument, Miteq, Cobham, E2V, MA-COM, Hittite, Mini-Circuits, General Dynamics и др.);

Помимо этого, одним из направлений компании «ЭлектроПласт» является направление «Источники питания». Мы предлагаем Вам помощь Конструкторского отдела:

- Подбор оптимального решения, техническое обоснование при выборе компонента;
- Подбор аналогов;
- Консультации по применению компонента;
- Поставка образцов и прототипов;
- Техническая поддержка проекта;
- Защита от снятия компонента с производства.



Как с нами связаться

Телефон: 8 (812) 309 58 32 (многоканальный)

Факс: 8 (812) 320-02-42

Электронная почта: org@eplast1.ru

Адрес: 198099, г. Санкт-Петербург, ул. Калинина, дом 2, корпус 4, литера А.