

Film Dielectric Trimmers

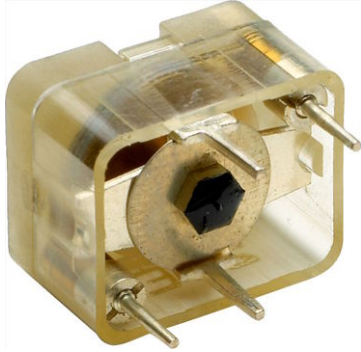

FEATURES

- High temperature type
- Housing dimensions:
8 mm x 9 mm x 10 mm
- For a basic grid of 2.54 mm
- Versions available with 1 or 2 rotor contacts
- Top and bottom adjustment
- Mounting: radial
- Material categorization: for definitions of compliance please see www.vishay.com/doc?99912

RoHS
COMPLIANT

APPLICATIONS

- Antennas
- Impedance matching circuits
- Medical
- RF
- For fine adjustment in professional applications

QUICK REFERENCE DATA		
Rated DC voltage	250 V _{DC}	
Test DC voltage for 1 min	500 V _{DC}	
Maximum contact resistance	5 mΩ	
Minimum insulation resistance	10 000 MΩ	
Category temperature range	-40 °C to +125 °C	
Climatic category (IEC 60068)	40/125/21	
Minimum storage temperature	-55 °C	
Related specification	IEC 60418-1 and 4	
Effective angle of rotation	180° (rotation in 180° only, see "Life of trimmer")	
Operating torque	C _{max.} = 5.5 pF	1 mNm to 15 mNm
	C _{max.} = 9 pF and 18 pF	1 mNm to 20 mNm
Maximum axial thrust	2 N	
Capacitance range (C _{min.} / C _{max.})	1.4 pF / 5.5 pF to 3 pF / 18 pF	
Life of trimmer	Maximum 10 cycles: rotation in 180° only (the electrical and mechanical performance is not guaranteed if rotated beyond 10 cycles)	
Quality level	Sampling and data evaluation for quality level in accordance with "MIL-STD-105D" and "IEC 60410": < 0.15 % major defects < 0.65 % minor defects Each capacitor is tested for minimum C _{max.} and is also subjected to the full test voltage.	



DIMENSIONS in millimeters

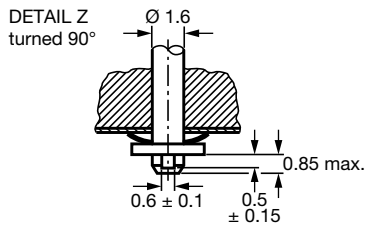
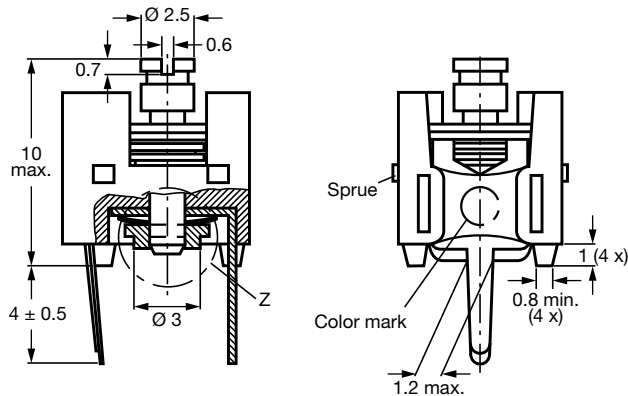

Trimmers BFC2 809 090.. series, with one rotor contact

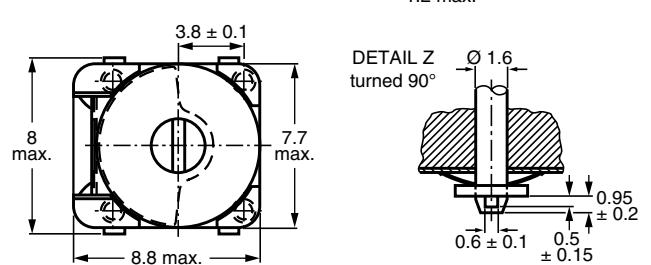
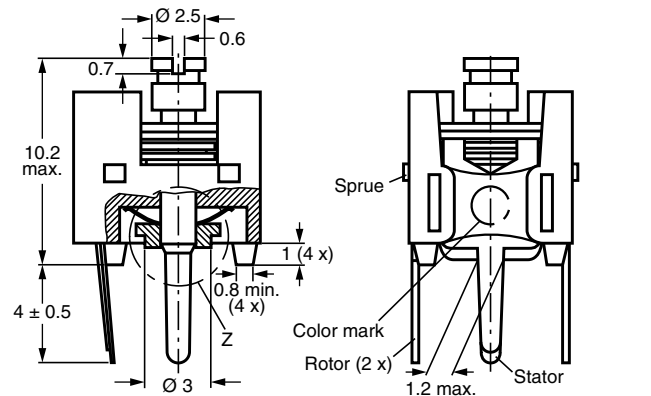

Trimmers BFC2 809 090.. series, with two rotor contacts

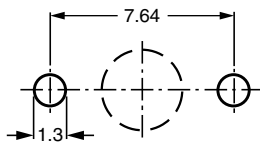

The large hole is for bottom adjustment and the diameter is determined by user's requirements.

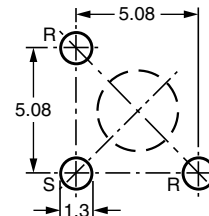

R = Rotor, S = Stator. The large hole is for bottom adjustment and the diameter is determined by user's requirements.

Hole pattern

ADJUSTMENT

For top adjustment a screwdriver or trimming key can be used; for bottom adjustment a key is required as shown below.

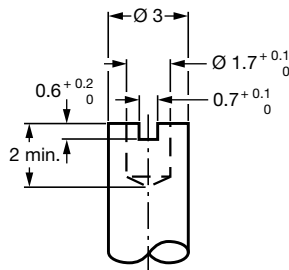

Bottom adjustment key

MOUNTING

The trimmer can be mounted on printed-circuit boards with a basic grid of 2.54 mm and a minimum hole diameter of 1.25 mm.

PACKAGING

Blister packs of 105 units each. For smallest packaging quantity (SPQ) see "Electrical Data" table.



ORDERING INFORMATION		
C _{min.} / C _{max.} (pF)	CATALOG NUMBER BFC2 809 090..	
	ROUND HEAD TOP AND BOTTOM ADJUSTMENT	
	VERSION WITH 1 ROTOR CONTACT	VERSION WITH 2 ROTOR CONTACTS
1.4 / 5.5	04	01
2 / 9	05	02
3 / 18	06	03

ELECTRICAL DATA											
GUARANTEED MAX. C _{min.} / MIN. C _{max.} AT 200 kHz (pF)	SHAPE OF HEAD	DIEL.	tan δ AT C _{max.} x 10 ⁻⁴		TEMP. COEFF. ⁽²⁾ (10 ⁻⁶ /K)	MIN. f _{res} AT C _{max.} (MHz)	COL. OF DOT	SPQ	CATALOG NUMBER BFC2		
			1 MHz	100 MHz							
1.4 / 5.5	Round	PTFE ⁽¹⁾	≤ 10	≤ 15	-250 ± 350	850	Green	525 809 09004 ⁽³⁾		
	Round							525 809 09001 ⁽⁴⁾		
2 / 9	Round							525 809 09005 ⁽³⁾		
	Round							525 809 09002 ⁽⁴⁾		
3 / 18	Round							360	Red	525 809 09006 ⁽³⁾
	Round									525 809 09003 ⁽⁴⁾

Notes

- (1) PTFE = Polytetrafluorethylene.
- (2) C: 60 % to 80 % of C_{max.}; T_{amb.}: from +20 °C to +125 °C.
- (3) Version with one rotor contact.
- (4) Version with two rotor contacts.

SOLDERING CONDITIONS

For general soldering conditions and wave soldering profile, we refer to the application note "Soldering Guidelines for Film Capacitors": www.vishay.com/doc?28171

TEST PROCEDURES AND REQUIREMENTS				
IEC 60418-1 CLAUSE	IEC 60068 TEST METHOD	TEST	PROCEDURE	REQUIREMENTS
4.2		Method of mounting	Method A	
14		Capacitance drift	After TC measurement	ΔC/C: ≤ 2.0 %; ≤ 3.0 % for 9 pF
19		Thrust	Axial thrust of 2 N	ΔC/C: ≤ 0.3 %
21		Robustness of terminations:		
21.1	Ua	Tensile	1 N	No damage
21.2	Ub	Bending	1 cycle	No damage
22	Na	Rapid change of temperature	1 cycle; 0.5 h at lower and 0.5 h at upper category temperature	ΔC/C: ≤ 3 %
23	T	Soldering:		
	Ta	Solderability	Solder bath immersion 3 mm; 235 °C; 2 s	Good wetting, no mechanical damage
	Tb	Resistance to heat	Solder bath: 260 °C; 10 s	No mechanical damage
24	Eb	Impact bump	4000 ± 10 bumps; 40 g; 6 ms	ΔC/C: ≤ 0.5 %; no mechanical damage



TEST PROCEDURES AND REQUIREMENTS				
IEC 60418-1 CLAUSE	IEC 60068 TEST METHOD	TEST	PROCEDURE	REQUIREMENTS
25	Fc	Vibration	Frequency 10 Hz to 55 Hz; amplitude 0.35 mm; 1.5 h	$\Delta C/C: \leq 0.3 \%$; no mechanical damage
26		Climatic sequence:		$\Delta C/C: \leq 2.5 \%$
26.1	B	Dry heat	16 h at upper category temperature	$\tan \delta: \leq 10 \times 10^{-4}$ $R_{ins.}: \geq 10\,000\,M\Omega$; Rotor contact R: $\leq 5\,m\Omega$
26.2	D	Damp heat accelerated, first cycle	1 cycle; 24 h; +40 °C; 95 % to 100 % RH	Voltage proof: 500 V for 1 min
26.3	Aa	Cold	16 h; -40 °C	Visual examination: no mechanical damage
26.5		Damp heat accelerated, remaining cycles	1 cycle; 24 h; +40 °C; 95 % to 100 % RH	Operating torque: 1 mNm to 20 mNm
27	Ca	Damp heat steady state	21 days; +40 °C; 90 % to 95 % RH	$\Delta C/C: \leq 3 \%$ $\tan \delta: \leq 10 \times 10^{-4}$ $R_{ins.}: \geq 10\,000\,M\Omega$; rotor contact R: $\leq 5\,m\Omega$ Voltage proof: 500 V for 1 min Visual examination: no mechanical damage Operating torque: 1 mNm to 20 mNm
29		Mechanical endurance	10 cycles Maximum 10 cycles: rotation in 180° only (the electrical and mechanical performance is not guaranteed if rotated beyond 10 cycles)	$\Delta C/C: \leq 3 \%$ $\Delta C/C$ after axial thrust: $\leq 0.3 \%$; rotor contact R: $\leq 5\,m\Omega$ Voltage proof: 500 V for 1 min Visual examination: no mechanical damage Operating torque: 1 mNm to 20 mNm



Disclaimer

ALL PRODUCT, PRODUCT SPECIFICATIONS AND DATA ARE SUBJECT TO CHANGE WITHOUT NOTICE TO IMPROVE RELIABILITY, FUNCTION OR DESIGN OR OTHERWISE.

Vishay Intertechnology, Inc., its affiliates, agents, and employees, and all persons acting on its or their behalf (collectively, "Vishay"), disclaim any and all liability for any errors, inaccuracies or incompleteness contained in any datasheet or in any other disclosure relating to any product.

Vishay makes no warranty, representation or guarantee regarding the suitability of the products for any particular purpose or the continuing production of any product. To the maximum extent permitted by applicable law, Vishay disclaims (i) any and all liability arising out of the application or use of any product, (ii) any and all liability, including without limitation special, consequential or incidental damages, and (iii) any and all implied warranties, including warranties of fitness for particular purpose, non-infringement and merchantability.

Statements regarding the suitability of products for certain types of applications are based on Vishay's knowledge of typical requirements that are often placed on Vishay products in generic applications. Such statements are not binding statements about the suitability of products for a particular application. It is the customer's responsibility to validate that a particular product with the properties described in the product specification is suitable for use in a particular application. Parameters provided in datasheets and/or specifications may vary in different applications and performance may vary over time. All operating parameters, including typical parameters, must be validated for each customer application by the customer's technical experts. Product specifications do not expand or otherwise modify Vishay's terms and conditions of purchase, including but not limited to the warranty expressed therein.

Except as expressly indicated in writing, Vishay products are not designed for use in medical, life-saving, or life-sustaining applications or for any other application in which the failure of the Vishay product could result in personal injury or death. Customers using or selling Vishay products not expressly indicated for use in such applications do so at their own risk. Please contact authorized Vishay personnel to obtain written terms and conditions regarding products designed for such applications.

No license, express or implied, by estoppel or otherwise, to any intellectual property rights is granted by this document or by any conduct of Vishay. Product names and markings noted herein may be trademarks of their respective owners.

Material Category Policy

Vishay Intertechnology, Inc. hereby certifies that all its products that are identified as RoHS-Compliant fulfill the definitions and restrictions defined under Directive 2011/65/EU of The European Parliament and of the Council of June 8, 2011 on the restriction of the use of certain hazardous substances in electrical and electronic equipment (EEE) - recast, unless otherwise specified as non-compliant.

Please note that some Vishay documentation may still make reference to RoHS Directive 2002/95/EC. We confirm that all the products identified as being compliant to Directive 2002/95/EC conform to Directive 2011/65/EU.

Vishay Intertechnology, Inc. hereby certifies that all its products that are identified as Halogen-Free follow Halogen-Free requirements as per JEDEC JS709A standards. Please note that some Vishay documentation may still make reference to the IEC 61249-2-21 definition. We confirm that all the products identified as being compliant to IEC 61249-2-21 conform to JEDEC JS709A standards.



Компания «ЭлектроПласт» предлагает заключение долгосрочных отношений при поставках импортных электронных компонентов на взаимовыгодных условиях!

Наши преимущества:

- Оперативные поставки широкого спектра электронных компонентов отечественного и импортного производства напрямую от производителей и с крупнейших мировых складов;
- Поставка более 17-ти миллионов наименований электронных компонентов;
- Поставка сложных, дефицитных, либо снятых с производства позиций;
- Оперативные сроки поставки под заказ (от 5 рабочих дней);
- Экспресс доставка в любую точку России;
- Техническая поддержка проекта, помощь в подборе аналогов, поставка прототипов;
- Система менеджмента качества сертифицирована по Международному стандарту ISO 9001;
- Лицензия ФСБ на осуществление работ с использованием сведений, составляющих государственную тайну;
- Поставка специализированных компонентов (Xilinx, Altera, Analog Devices, Intersil, Interpoint, Microsemi, Aeroflex, Peregrine, Syfer, Eurofarad, Texas Instrument, Miteq, Cobham, E2V, MA-COM, Hittite, Mini-Circuits, General Dynamics и др.);

Помимо этого, одним из направлений компании «ЭлектроПласт» является направление «Источники питания». Мы предлагаем Вам помощь Конструкторского отдела:

- Подбор оптимального решения, техническое обоснование при выборе компонента;
- Подбор аналогов;
- Консультации по применению компонента;
- Поставка образцов и прототипов;
- Техническая поддержка проекта;
- Защита от снятия компонента с производства.



Как с нами связаться

Телефон: 8 (812) 309 58 32 (многоканальный)

Факс: 8 (812) 320-02-42

Электронная почта: org@eplast1.ru

Адрес: 198099, г. Санкт-Петербург, ул. Калинина, дом 2, корпус 4, литера А.