

\*RoHS COMPLIANT



**BOURNS®**

**Features**

- Carbon element
- Insulated shaft
- Snap-in clip
- Center detent
- Center tap option
- Assorted pin layouts
- Dual gang option
- Various taper options

**PTV/PTT Series - 12 mm Potentiometer**

**Electrical Characteristics**

Taper..... Linear, audio  
 Standard Resistance Range ..... 1 K ohms to 1 M ohms  
 Standard Resistance Tolerance.....±20 %  
 Residual Resistance..... 1 % max.

**Environmental Characteristics**

Operating Temperature ..... -10 °C to +50 °C  
 Power Rating ..... 0.05 Watt  
 Maximum Operating Voltage ..... 50 V AC, 20 V DC  
 Sliding Noise ..... 100 mV max.

**Mechanical Characteristics**

Mechanical Angle ..... 300 ° ±5 °  
 Rotational Torque ..... 20 to 200 g-cm  
 Detent Torque ..... 30 to 300 g-cm  
 Stop Strength  
 no bushing ..... 3 kg-cm min.  
 with bushing..... 3 kg-cm min.  
 Rotational Life ..... 15,000 cycles  
 Soldering Condition  
 .....300 °C max. within 3 seconds  
 Hardware ..... One flat washer and mounting nut supplied per potentiometer with bushing

**Electrical Diagrams**

MODEL PTV 111

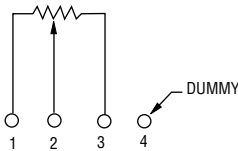

MODEL PTV 112

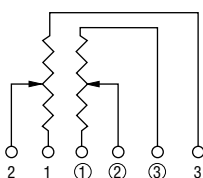

MODEL PTT 111

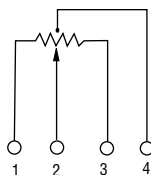

**Product Dimensions**

PTV111-2

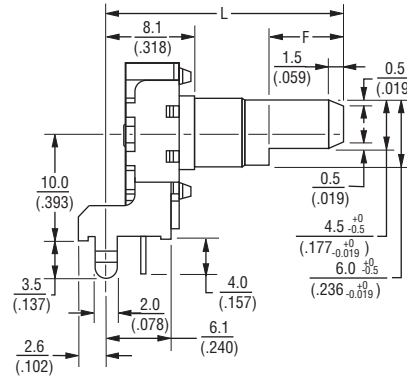

PTV111-4

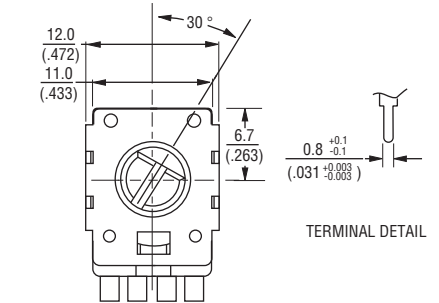
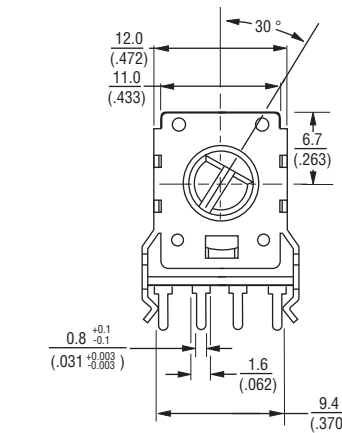
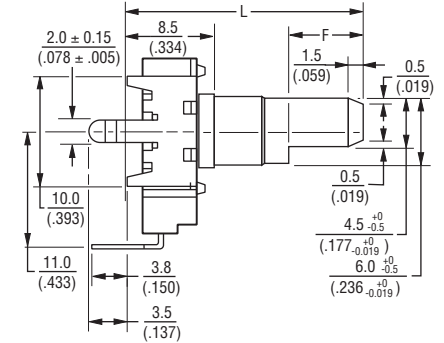

RECOMMENDED PCB LAYOUT

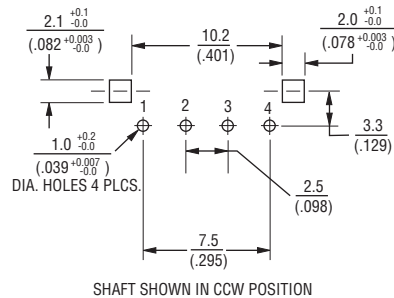

RECOMMENDED PCB LAYOUT

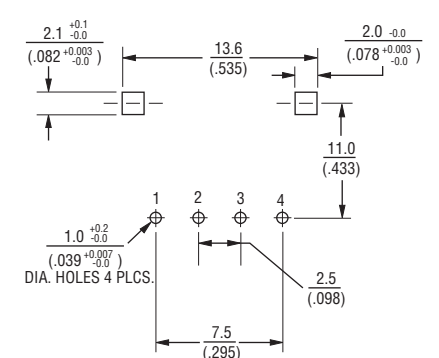

**Dimensions Without Bushing**

L	15 (.591)	20 (.787)	22.5 (.886)	25 (.984)	27.5 (1.083)
F	4.5 (.177)	7 (.276)	7 (.276)	12 (.472)	12 (.472)

DIMENSIONS:  $\frac{MM}{(INCHES)}$

\*RoHS Directive 2002/95/EC Jan. 27, 2003 including annex and RoHS Recast 2011/65/EU June 8, 2011. Specifications are subject to change without notice. The device characteristics and parameters in this data sheet can and do vary in different applications and actual device performance may vary over time. Users should verify actual device performance in their specific applications.

## Applications

- Audio/TV sets
- Car radio
- Amplifiers/mixers/drum machines/synthesizers
- PCs/monitors
- Appliances

## PTV/PTT Series - 12 mm Potentiometer

**BOURNS®**

### Product Dimensions

PTV111-1

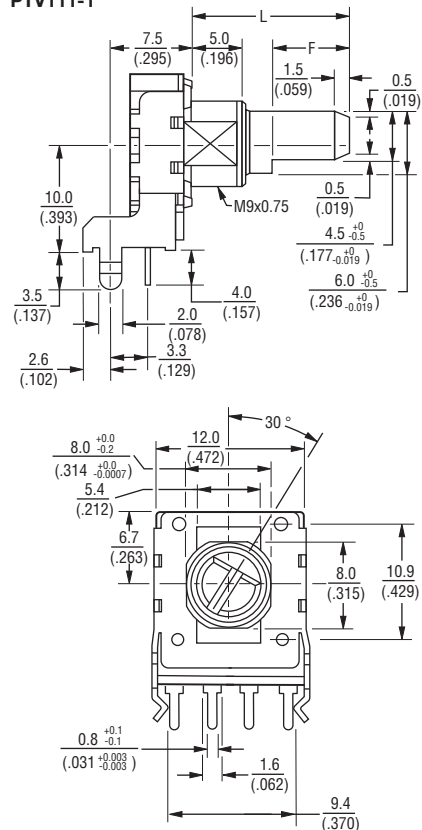

RECOMMENDED PCB LAYOUT

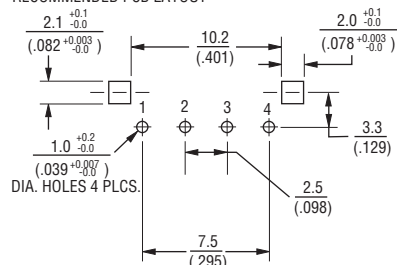

SHAFT SHOWN IN CCW POSITION

PTV111-3

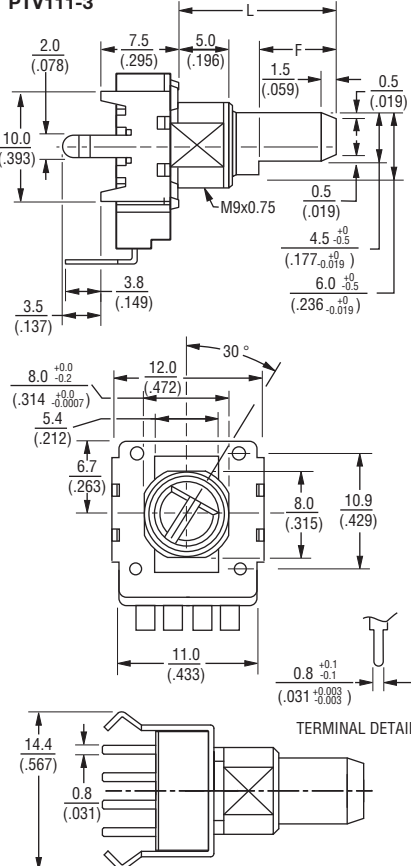

RECOMMENDED PCB LAYOUT

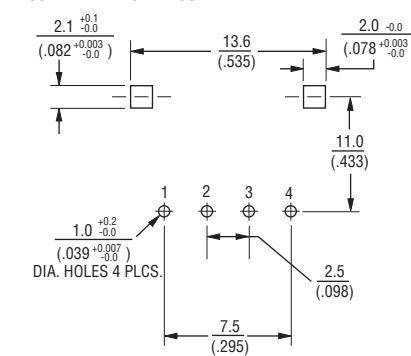

SHAFT SHOWN IN CCW POSITION

PTV112-4 DUAL GANG

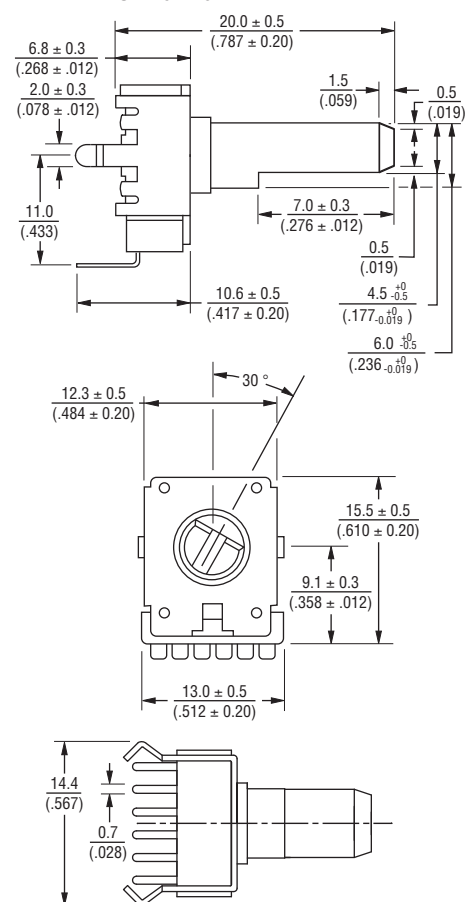

RECOMMENDED PCB LAYOUT

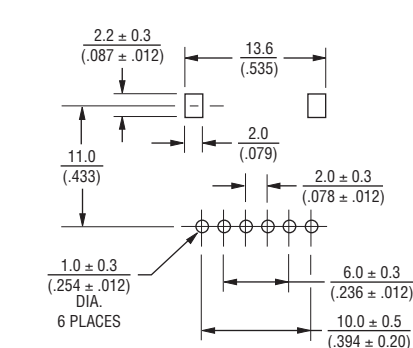

SHAFT SHOWN IN CCW POSITION

### Dimensions Without Bushing

L	12.5 (.492)	15 (.591)	17.5 (.689)	20 (.787)
F	7 (.276)	7 (.276)	12 (.472)	12 (.472)

DIMENSIONS:  $\frac{\text{MM}}{\text{(INCHES)}}$

Specifications are subject to change without notice.

The device characteristics and parameters in this data sheet can and do vary in different applications and actual device performance may vary over time. Users should verify actual device performance in their specific applications.

# PTV/PTT Series - 12 mm Potentiometer

**BOURNS®**

## How To Order

**PTV111 - 2 4 20 A - A1 104**

Model

(See Diagrams)

- PTV111 Standard
- PTT111 With Tap
- PTV112 Dual Gang

Pin Style

PC Pins vertical/  
Down Facing:

- 1 = With Bushing
- 2 = No Bushing

PC Pins horizontal/  
Rear Facing:

- 3 = With Bushing
- 4 = No Bushing

Center Detent Option

- 4 = No Detent
- 2 = Center Detent

Standard Shaft Length

- 12 = 12.5 mm\*
- 15 = 15 mm
- 17 = 17.5 mm\*
- 20 = 20 mm
- 22 = 22.5 mm\*\*
- 25 = 25 mm\*\*
- 27 = 27.5 mm\*\*

Shaft Styles

- A = Flat Type Insulated Shaft

Resistance Taper (See Taper Chart)

Taper Series followed by Curve Number

Resistance Code (See Table)

Other styles available.

\* Available with Pin Styles 1 & 3 only.

\*\* Available with Pin Styles 2 & 4 only.

## Standard Resistance Table

Resistance (Ohms)	Resistance Code
1,000	102
2,000	202
5,000	502
10,000	103
20,000	203
50,000	503
100,000	104
200,000	204
500,000	504
1,000,000	105

## Derating Curve

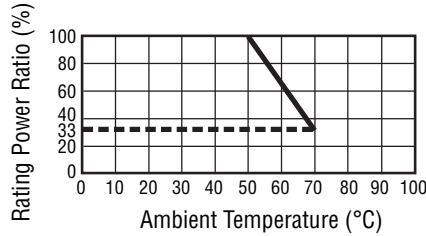

## Tapers

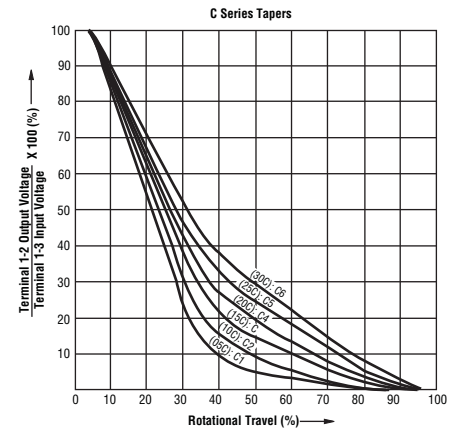
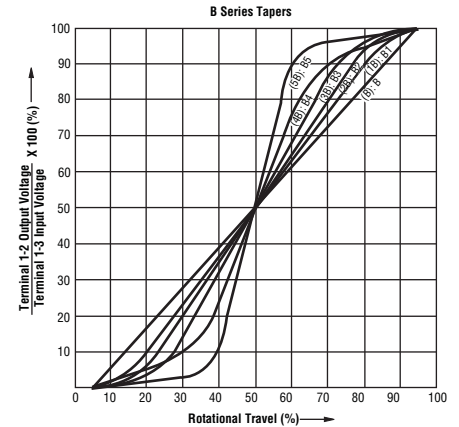
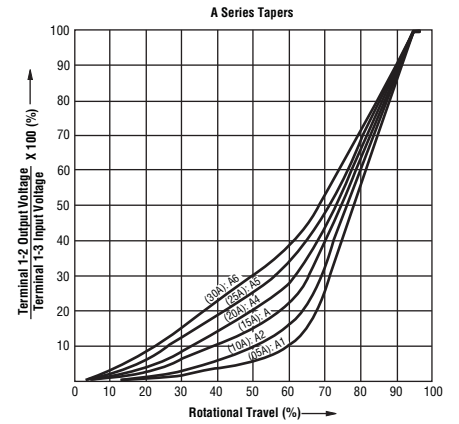

REV. 07/15

Specifications are subject to change without notice.

The device characteristics and parameters in this data sheet can and do vary in different applications and actual device performance may vary over time.

Users should verify actual device performance in their specific applications.



Компания «ЭлектроПласт» предлагает заключение долгосрочных отношений при поставках импортных электронных компонентов на взаимовыгодных условиях!

Наши преимущества:

- Оперативные поставки широкого спектра электронных компонентов отечественного и импортного производства напрямую от производителей и с крупнейших мировых складов;
- Поставка более 17-ти миллионов наименований электронных компонентов;
- Поставка сложных, дефицитных, либо снятых с производства позиций;
- Оперативные сроки поставки под заказ (от 5 рабочих дней);
- Экспресс доставка в любую точку России;
- Техническая поддержка проекта, помощь в подборе аналогов, поставка прототипов;
- Система менеджмента качества сертифицирована по Международному стандарту ISO 9001;
- Лицензия ФСБ на осуществление работ с использованием сведений, составляющих государственную тайну;
- Поставка специализированных компонентов (Xilinx, Altera, Analog Devices, Intersil, Interpoint, Microsemi, Aeroflex, Peregrine, Syfer, Eurofarad, Texas Instrument, Miteq, Cobham, E2V, MA-COM, Hittite, Mini-Circuits, General Dynamics и др.);

Помимо этого, одним из направлений компании «ЭлектроПласт» является направление «Источники питания». Мы предлагаем Вам помощь Конструкторского отдела:

- Подбор оптимального решения, техническое обоснование при выборе компонента;
- Подбор аналогов;
- Консультации по применению компонента;
- Поставка образцов и прототипов;
- Техническая поддержка проекта;
- Защита от снятия компонента с производства.



#### Как с нами связаться

**Телефон:** 8 (812) 309 58 32 (многоканальный)

**Факс:** 8 (812) 320-02-42

**Электронная почта:** [org@eplast1.ru](mailto:org@eplast1.ru)

**Адрес:** 198099, г. Санкт-Петербург, ул. Калинина, дом 2, корпус 4, литера А.