



FEATURES

- 1600W output power (across the full DC input voltage range)
- 1.57"(1U) x 11.0" x 3.2"
- 93% typical efficiency at 50% FL
- 12VDC Main output
- 3.3VSB output (20W)
- 29W/in³ power density
- N+1 Redundancy Capable; hot plug/swap (up to 8 modules in parallel)
- Active current sharing on 12V main output; integral MOSFET ORING
- Over-Voltage, Over-Current; Over-Temperature Protection
- Internal variable speed cooling fans
- PMBus™ Power Management Bus
- RoHS Compliant

PRODUCT OVERVIEW

The D1U3CS-D-1600-12-HC4EC is a highly efficient 1600 watt, DC input front end module with a 12V main output and a choice of 3.3V (20W) standby and airflow direction. The power module is able to current share with up to eight (8) other power modules of the same type operating in parallel or N+1 redundancy.

The supplies may be hot plugged, and include integral isolation devices.

The power modules are fully protected from overload and overvoltage and are able to auto-recover from overtemperature faults. A Status LED is provided on the front panel and additional control and status reporting is provided by hardware logic signals and via a PMBus™ digital interface.

A low profile sub 1U height enclosure provides an excellent power density of 29W/in³ that is ideal for delivering reliable, efficient power to servers; workstations; storage systems and other 12V distributed power systems.

ORDERING GUIDE

Model Number	Power Output	Main Output	Standby Output	Airflow
D1U3CS-D-1600-12-HC4EC	1600W	12Vdc	3.3Vdc	Back to Front

INPUT CHARACTERISTICS

Parameter	Conditions	Min	Typ	Max	Units
DC Input Voltage Operating Range		-40	-48/-60	-72	
Turn-on Input Voltage	Ramp Up	-39.5	-40	-40.5	Vdc
Turn-off Input Voltage	Ramp Down	-35.5	-36	-36.5	
Maximum Current @ VIN = -48Vdc	1600W			40	Adc
DC Input Inrush Peak Current	Cold start between 0 to 200ms	-40		50	Apk
		-72		100	
Efficiency (-48Vdc)	20% FL		92		%
	50% FL		93		
	100% FL		90		
Reverse polarity protection	Reversed input cables; no internal fuse failure	+40		+72	Vdc

OUTPUT VOLTAGE CHARACTERISTICS

Output Voltage	Parameter	Conditions	Min	Typ	Max	Units
Main 12V	Voltage Set Point Accuracy			12		Vdc
	Line & Load Regulation		11.4		12.6	
	Ripple & Noise ¹	20MHz Bandwidth			120	mV _{PP}
	Output Current	-40Vdc to -72Vdc DC Input Voltage Range	0		133A	A
	Load Capacitance				30,000	μF
3.3VSB	Voltage Set Point			3.3		Vdc
	Line & Load Regulation		3.2		3.4	
	Ripple Voltage & Noise ¹	20MHz Bandwidth			120	mV _{PP}
	Output Current	-40Vdc to -72Vdc	0		6	A
	Load Capacitance				10,000	μF

¹ Ripple and noise are measurements are to be performed with a parallel combination of a 0.1μF ceramic capacitor and 10μF tantalum capacitance on each of the power module output measurement nodes. A short coaxial cable from measurement point to 'scope shall be used.



Available now at
www.murata-ps.com/en/3d/acdc.html



OUTPUT CHARACTERISTICS					
Parameter	Conditions	Min	Typ	Max	Units
Remote Sense (Main Output)	Overall compensation at full load; +VE & -VE connections			120	mV
Output Rise (Monotonic)	10% to 95% rise time	No positive voltage excursion			
Startup Time	DC Ramp Up		1.5	2.5	s
	PS_ON activation		200		ms
Transient Response	12V, 50%-100% or 100%-50% step load; 1A/μs slew rate		±600		mV
	3.3SB 50-100% or 100%-50% step load 1A/μs slew rate		±165		
Current Sharing Accuracy	At 100% load (between sharing modules; up to 8 in parallel)			±10	%
Hot Swap Transients				±5	%
Hold Up Time ²	FL (Full Load)			1	ms

² Assumes deployment on systems with dual redundant "A" and "B" DC input feeds

ENVIRONMENTAL CHARACTERISTICS					
Parameter	Conditions	Min	Typ	Max	Units
Storage Temperature Range	Non-Condensing	-40		70	°C
Operating Temperature Range	1600W Output Power	0		50	
Operating Humidity	Non-Condensing	5		95	%
Storage Humidity		5		90	
Altitude (no derating at 40°C)		3000			m
Altitude (no derating at 50°C)		1800			
Shock	Non-Operating			30	G
Sinusoidal Vibration	Operational, 0.5G; 5-500Hz				
MTBF	Telcordia SR-332 M1C1 @ 40°C		395		K Hours
Safety Approvals (Standards)	CSA/CSA-C22.2 No.60950-1-07 2nd Ed, Amendment 1:2011 ANSI/UL Std. No. 60950-1-2011 IEC 60950-1:2005, (2nd Edition) + A1:2009 CE Marking per LVD DIRECTIVE 2006/95/EC				
Input Fusing	Internal 60A/170Vdc fast blow fuse on the DC line input				
Switching Frequency	70KHz for the Boost Converter; 240KHz for the Main Output Converter				
Material Flammability	UL94-V0				
Weight				2.84/1.31	lbs/kg

PROTECTION CHARACTERISTICS						
Output	Parameter	Conditions	Min.	Typ.	Max.	Units
N/A	Over-Temp	Auto re-start	57	60	63	°C
12V (Main)	Over-Voltage	Latching; toggle PS_ON or recycle DC input to reset	13.3		14.5	V
	Over-Current	For slow overload events a constant current will be sustained for 1sec followed by a latch off that will auto reset in 5secs. For hard (short circuit) events the output will shut down within 50ms and auto restart within 200ms. This cycle will be repeated ten times at which point the output will permanently latch off. The power module will require to be reset by recycling the incoming DC source or "togglng" PS_ON.	140		160	A
3.3VSB	Over-Voltage	Latching; toggle PS_ON or recycle DC input to reset	3.9		4.3	V
	Over-Current	Shutdown followed by auto-recovery	6.5		9.0	A

ISOLATION CHARACTERISTICS					
Parameter	Conditions	Min.	Typ.	Max.	Units
Isolation	Input to Output - Basic	1000			Vdc
	Output to Chassis (Ground)	500			Vdc

STATUS INDICATORS	
Conditions	LED Status
No incoming DC supply present; power module completely unpowered (off).	LED not illuminated
Standby Rail ON; Main Output OFF; DC input present & correct	Blinking Green
Standby Rail ON; Main Output ON	Solid Green
Main Output overcurrent; undervoltage, overvoltage warning	Blinking Amber
FAN_FAULT; overtemperature; standby rail overcurrent, Main Output overcurrent or overvoltage	Solid Amber

EMISSIONS AND IMMUNITY		
Characteristic	Standard	Compliance
Conducted Emissions	FCC 47 CFR Part 15; CSIPR 22/EN55022	Class B
ESD Immunity	IEC/EN 61000-4-2;	Level 3; Criteria A
Radiated Field Immunity	IEC/EN 61000-4-3	Level 3; Criteria B
Electrical Fast Transients/Burst Immunity	IEC/EN 61000-4-4	Level 3; Criteria B
Surge Immunity	IEC/EN 61000-4-5	Level 3; Criteria A
RF Conducted Immunity	IEC/EN 61000-4-6	Level 3; Criteria A
Magnetic Field Immunity	IEC/EN 61000-4-8	3A/m; Criteria B
Voltage Dips & Interruptions	NEBS GR-1089-CORE Issue	Relevant sections and compliance levels TBD

OUTPUT CONNECTOR & SIGNAL INTERFACE											
DC Output and Signal Connector: FCI# 51731-057-LF											
D1	D2	D3	D4	D5	D6						
C1	C2	C3	C4	C5	C6						
B1	B2	B3	B4	B5	B6	PB1	PB2	PB3	PB4	PB5	PB6
A1	A2	A3	A4	A5	A6						

NB: B4 is the shortest "last make, first break" sequenced signal pin.

Blade Assignment	Function	Description	Current (Amps per Pin)
PB1, PB2, PB3	+12V GND	Main Output Voltage, Return	30
PB4, PB5, PB6	+12V OUT	Main Output Voltage	30
Signal Pin Assignment	Signal Name	Description	
A1	PS_ON_L	An input pulled up via an internal 10K ohm to the Standby rail. When pulled low (<0.7Vdc; via an open collector/drain drive or connection to GND) the Main Output will be turned on/enabled)	N/A
A2	+12VRS_RETURN	Main Output Remote Sense (-VE/Return)	N/A
A3	TEMP_OK	TTL compatible Logic HIGH provided when the temperature is within the allowable range of operation.	
A4	PS_SEATED (PS_PRESENT)	Internally connected to GND within the power module; when correctly seated the corresponding mating connector pin is grounded and therefore allows detection that the power module is in situ.	N/A
A5, B5, C5, D5	+VSB	Standby Voltage Output	2.0
A6, B6, C6, D6	+VSB GND	Standby Voltage Output, Return/GND	2.0
B1	DC_OK	A TTL Logic HIGH (>2.1Vdc) is provided to indicate the DC Input is present ("OK") and within operational limits.	N/A
B2	+12VRS	Main 12V output remote sense line.	N/A
B3	+12V_ISHARE	Main 12V output current share bus (see Current Sharing Notes).	N/A
B4	PS_INHIBIT/PS_KILL	This is the shortest "last make, first break" (last to mate in the sequence). If left open circuit then the Main & Standby outputs will be inhibited (no output). When inserted in to the system slot this pin must be pulled "low" by the system to enable (turn on) the Main output and only after all other pins are connected and the power module is correctly seated.	N/A
C1	SDA	I ² C Serial Data Line	N/A
C2	SCL	I ² C Serial Clock Line	N/A
C3	PWR_GD	Power Good signal. An active TTL HIGH signifies when the output is within regulation limits.	N/A
C4	FAN_FAIL	Fan Fail signal (failure or locked rotor)	N/A
D1	A0	I ² C LSB (Least Significant Bit) Address Line	N/A
D2	A1	I ² C MSB (Most Significant Bit) Address Line	N/A
D3	S_INT	System Interrupt; call for system attention to check power module status	N/A
D4	N/C	No User Connection	N/A

MATING CONNECTOR				
Supplier	Press Fit, Straight	Press Fit, Right Angle	Solder Straight	Solder Right Angle
FCI	---	---	---	51761-10002406ABLF

DC INPUT TERMINAL BLOCK		
Dinkle Enterprise	2 Way Terminal Block; 40A rating; +VE & -VE DC Input cable connections	DT-7C-B14W

WIRING DIAGRAM FOR OUTPUT

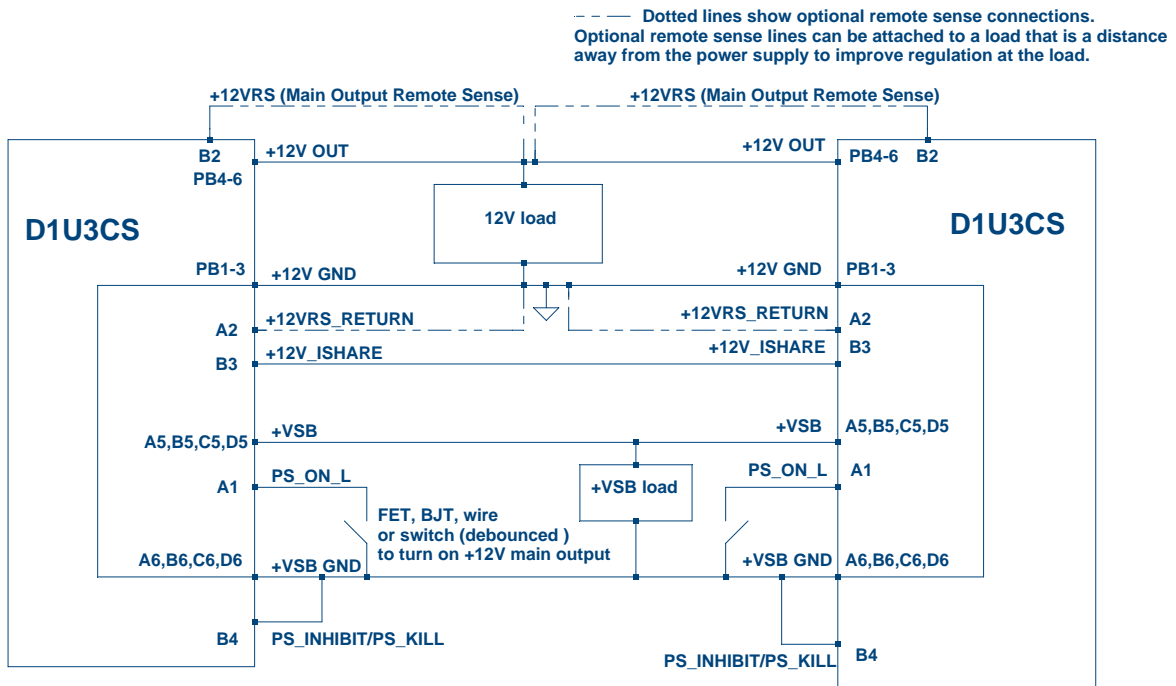

CURRENT SHARING NOTES

1. Main 12VDC Output: Analogue active share bus. The ISHARE bus (Pin B3) must be connected on all sharing modules.
It is not required that the SENSE signals are connected to the remote load for current share to operate correctly.
2. Up to eight (8) power modules can be connected in parallel (non-redundant) or N+1 configuration. The current share bus is analogue bi-directional (can source or sink voltage representation of the current on the ISHARE bus).
The voltage of the bus would measure 8VDC for a single power module at 100% load; for two (2) modules sharing a common load the ISHARE bus voltage would be 4V for a perfect 50/50 current share scenario.
3. The VSTANDBY output of power modules can also be connected in parallel and have internal output isolation devices; however the combined available power is limited to that available from a single power module (3.3V; 20W) irrespective of the number of modules connected in parallel.

MECHANICAL DIMENSIONS

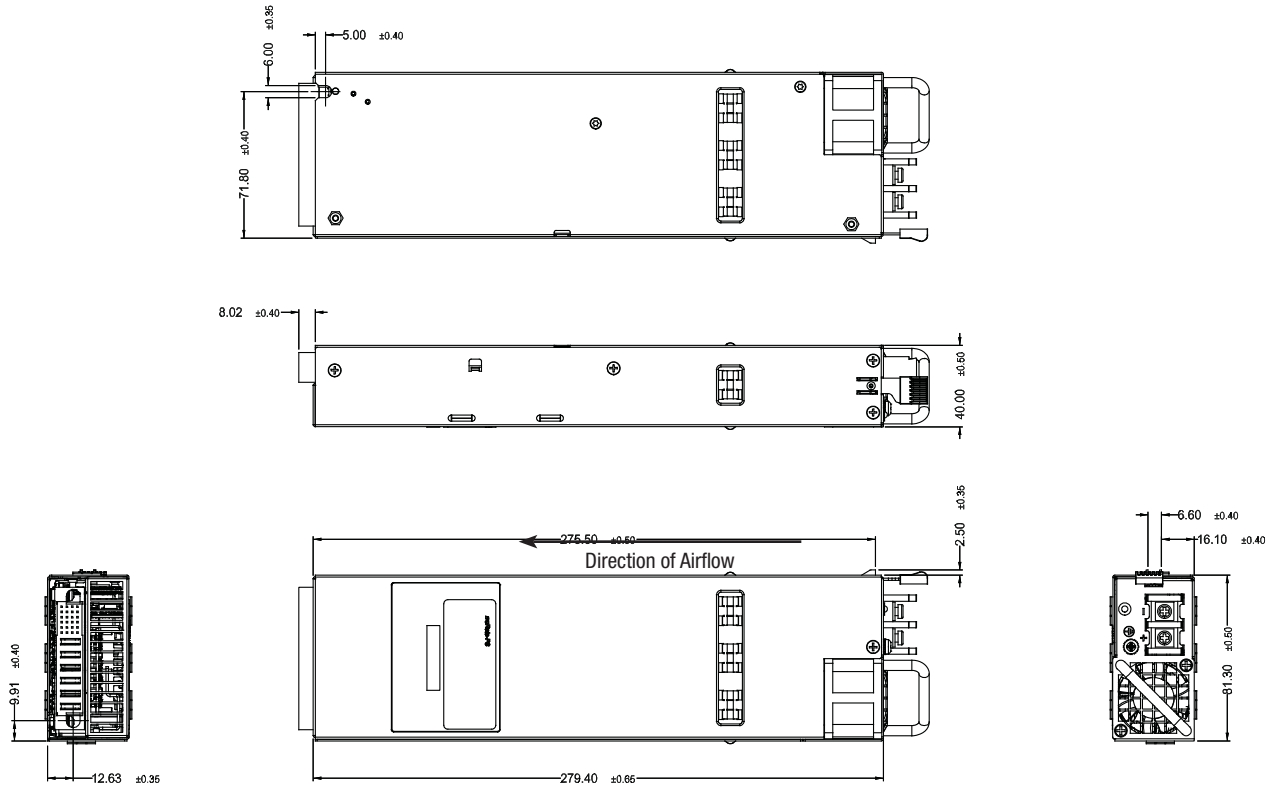

Notes

1. Dimensions: 3.20" x 11.00" x 1.57" (81.3mm x 279.4mm x 39.9mm)
2. Safety earth/ground connection via separate dedicated M4 pan head screw connection (located above terminal block)

OPTIONAL ACCESSORIES

Description	Part Number
D1U3CS-12 Output Interface Connector Card	D1U3CS-12-CONC

APPLICATION NOTES

Document Number	Description	Link
ACAN-41	D1U3CS-12-CONC Output Interface Connector Card	www.murata-ps.com/data/apnotes/acan-41.pdf
ACAN-57	D1U3CS-12 Communications Protocol	

Murata Power Solutions, Inc.
 11 Cabot Boulevard, Mansfield, MA 02048-1151 U.S.A.
 ISO 9001 and 14001 REGISTERED



This product is subject to the following operating requirements and the Life and Safety Critical Application Sales Policy:
 Refer to: <http://www.murata-ps.com/requirements/>

Murata Power Solutions, Inc. makes no representation that the use of its products in the circuits described herein, or the use of other technical information contained herein, will not infringe upon existing or future patent rights. The descriptions contained herein do not imply the granting of licenses to make, use, or sell equipment constructed in accordance therewith. Specifications are subject to change without notice. © 2015 Murata Power Solutions, Inc.



Компания «ЭлектроПласт» предлагает заключение долгосрочных отношений при поставках импортных электронных компонентов на взаимовыгодных условиях!

Наши преимущества:

- Оперативные поставки широкого спектра электронных компонентов отечественного и импортного производства напрямую от производителей и с крупнейших мировых складов;
- Поставка более 17-ти миллионов наименований электронных компонентов;
- Поставка сложных, дефицитных, либо снятых с производства позиций;
- Оперативные сроки поставки под заказ (от 5 рабочих дней);
- Экспресс доставка в любую точку России;
- Техническая поддержка проекта, помощь в подборе аналогов, поставка прототипов;
- Система менеджмента качества сертифицирована по Международному стандарту ISO 9001;
- Лицензия ФСБ на осуществление работ с использованием сведений, составляющих государственную тайну;
- Поставка специализированных компонентов (Xilinx, Altera, Analog Devices, Intersil, Interpoint, Microsemi, Aeroflex, Peregrine, Syfer, Eurofarad, Texas Instrument, Miteq, Cobham, E2V, MA-COM, Hittite, Mini-Circuits, General Dynamics и др.);

Помимо этого, одним из направлений компании «ЭлектроПласт» является направление «Источники питания». Мы предлагаем Вам помощь Конструкторского отдела:

- Подбор оптимального решения, техническое обоснование при выборе компонента;
- Подбор аналогов;
- Консультации по применению компонента;
- Поставка образцов и прототипов;
- Техническая поддержка проекта;
- Защита от снятия компонента с производства.



Как с нами связаться

Телефон: 8 (812) 309 58 32 (многоканальный)

Факс: 8 (812) 320-02-42

Электронная почта: org@eplast1.ru

Адрес: 198099, г. Санкт-Петербург, ул. Калинина, дом 2, корпус 4, литера А.