

LTC2972

2-Channel PMBus Power System Manager with Eight Power Supply Rails

DESCRIPTION

The DC2619A is a demonstration system for the [LTC®2972](#) power system manager that interfaces to various regulators. The board contains all the circuitry needed to demonstrate a power system that utilizes four 2-channel LTC2972 devices that manage eight power supplies. The eight power supplies include linear and switching regulators for the purpose of demonstrating a variety of methods to sense voltage and current. The demo board provides a sophisticated 8-channel programmable power supply system.

The LTC2972 is a 2-channel I²C/SMBus/PMBus power system manager that features accurate input current and energy measurement. The device monitors input current and input voltage, and calculates input power and energy. The DC2619A demonstrates the ability of the LTC2972 to sequence, trim, margin, supervise, monitor, and log faults for eight power supplies. The LTC2972 monitors each channel's output voltage and output current and also monitors external temperature sensors and its own internal die temperature.

The DC2619A board contains eight independent power supply rails. The +5V/-5V rails are based on the switched capacitor LTC3260 regulator, the 1.0V/1.2V rails are powered by an LTC3633 switching regulator, the 1.5V/1.8V rails are powered by LTC3405A switching regulators, and the 2.5/3.3V rails are powered by LT3086/LT3055 linear regulators. The board is pre-configured with these voltages and may be re-configured with feedback resistors.

The LTpowerPlay® graphical user interface (GUI) supports this demonstration system and enables complete control of all the features of the LTC2972. Together, the LTpowerPlay software and DC2619A hardware system create a powerful development environment for designing and testing configuration settings of the LTC2972. LTpowerPlay stores these settings in the LTC2972's internal EEPROM or in a project file. The software

displays all of the configuration settings and real time measurements from the power system management IC. Telemetry allows easy access and decoding of the fault log created by the LTC2972. The board comes pre-programmed with the EEPROM values appropriate for the eight power supply rails on the DC2619A. Just plug and play!

Order pre-programmed devices from Linear Express® using LTpowerPlay.

The following items are required:

- +12VDC Power Supply
- USB-to-I²C/SMBus/PMBus Controller (DC1613)
- LTpowerPlay Software

DC2619A FEATURES

- Sequence, Trim, Margin and Supervise Eight Power Supplies
- Manage Faults, Monitor Telemetry, Create Fault Logs
- PMBus Compliant Command Set
- Supported by LTpowerPlay GUI
- Margin or Trim Supplies to 0.25% Accuracy
- Eight I_{OUT} and Four I_{IN} Monitors
- Input Power Measurement and Energy Accumulation
- Fast OV/UV Supervisors Per Channel
- Multi-Channel Fault Management
- Automatic Fault Logging to Internal EEPROM
- Operates Autonomously without Additional Software
- Monitors: Voltage, Current, Power, Temperature
- Time-Based Output Sequencer
- I²C/SMBus Serial Interface
- Powered from 8V to 14V

All registered trademarks and trademarks are the property of their respective owners. Protected by U.S. Patents including 7382303, 7420359, and 7940091.

DEMO MANUAL DC2619A

PERFORMANCE SUMMARY Specifications are at T_A = 25°C

PARAMETER	CONDITIONS	MIN	TYP	MAX	VALUE
VPWR Supply Input Operating Range		4.5		15	V
VDD33 Supply Input Operating Range		3.13		3.47	V
ADC Total Unadjusted Error	V _{IN} ≥ 1V		±0.25		%
ADC Voltage Sensing Input Range		-0.1		6	V
ADC Current Sensing Input Range	Differential Current Sense Voltage	-170		170	mV
ADC Voltage Sensing Resolution	0V ≤ V _{IN_ADC} ≤ 6V		122		μV/LSB
ADC Current Sense Resolution	0mV < V _{IN_ADC} < 16mV 16mV < V _{IN_ADC} < 32mV 32mV < V _{IN_ADC} < 63.9mV 63.9mV < V _{IN_ADC} < 127.9mV 127.9mV < V _{IN_ADC}		15.6 31.25 62.5 125 250		μV/LSB μV/LSB μV/LSB μV/LSB μV/LSB
DAC Resolution			10		bits
DAC Full Scale Output Voltage	Buffer Gain Setting 0 Typ. Buffer Gain Setting 1 Typ.		1.38 2.65		V V
Temperature Sensor TUE			±1		°C
Voltage Supervisor Input Voltage Range (Programmable)	V _{SENSE[n]} (Low Resolution) (High Resolution)	0 0		6 3.8	V V
Voltage Supervisor Sensing Resolution	0V to 3.8V range: 4.096/1024 0V to 6V range: 8.192/1024		4 8		mV/LSB mV/LSB
Voltage Supervisor Total Unadjusted Error (TUE)	2V < V _{IN_VS} < 6V, Low Resolution Mode 1.5V < V _{IN_VS} < 3.8V, High Resolution Mode 0.8V < V _{IN_VS} < 1.5V, High Resolution Mode		±1.25 ±1.0 ±1.5		% % %
I ² C Serial Clock Frequency		10		400	kHz

Table 1. Demo Board System Specifications

	NOMINAL UNTRIMMED V _{OUT}	REGULATOR PART NUMBER	RESISTORS THAT SET UNTRIMMED V _{OUT}	R _{DAC}	MARGIN RANGE	CURRENT SENSE METHOD
CH0	+5V ±1%	LTC3260	R1, R2	R13	±10%	R _{SENSE}
CH1	-5V ±1%		R3, R4	R14, R15	±10%	LT6015
CH2	+1.0V ±1%	LTC3633	R23, R24	R27	±5%	R _{SENSE}
CH3	+1.2V ±1%		R25, R26	R28	±5%	R _{SENSE}
CH4	+1.5V ±1%	LTC3405A	R39, R40	R41	±10%	DCR
CH5	+1.8V ±1%	LTC3405A	R45, R46	R47	±10%	DCR
CH6	+2.5V ±1%	LT3086	R53	R55	±5%	IMON
CH7	+3.3V ±1%	LT3055	R58, R59	R61	±5%	IMON

Notes:

Note 1: Keep load currents < 50mA on ±5V channels, < 1.5A on 1.0V/1.2V channels, < 300mA on 1.5V/1.8V channels, < 1A on 2.5V channel, and < 0.5A on 3.3V channel.

Note 2: Output voltages can be margined by ±5% or ±10% from nominal with the default resistor values. These values can be easily changed. See section Changing Nominal Output Voltages. Use the LTC2972 Resistor Selection Tool which is accessed from LTpowerPlay.

GLOSSARY OF TERMS

The following list contains terms used throughout the document.

Channel: The collection of functions that monitor, supervise, and trim a given power supply rail.

EEPROM: Nonvolatile memory (NVM) storage used to retain data after power is removed.

Margin: Term used typically in board level testing that increases/decreases the output voltage to look for sensitivity/marginality problems.

Monitor: The act of measuring voltage, current, and temperature readings.

NVM: Nonvolatile memory, see EEPROM.

OV: Overvoltage, the result of a voltage comparison that a pin voltage is above a programmable threshold voltage.

PMBus: An industry standard power-management protocol with a fully defined command language that facilitates communication with power converters and other devices in a power system.

Rail: The final output voltage that the LTC2972 monitors and supervises.

Supervise: The act of quickly responding (compared to a fault setting) to a voltage and current condition that is compared to pre-programmed values.

Trim: The act of adjusting the final output voltage. A servo loop trims the output voltage.

UV: Undervoltage, the result of a voltage comparison that a pin voltage is below a programmable threshold voltage.

WHAT THIS DEMO SYSTEM CAN DO

- Prototype your system by modifying: nominal output voltages, range and resolution of margining, sequencing, OV/UV limits, and OC limits.
- Create your own configuration: store in the LTC2972 EEPROM or save to a project file. Order pre-programmed parts.
- Test fault scenarios. Short outputs to ground, and observe system response and faults.

Demo System Hardware

Hardware required:

1. DC2619A
2. PC + USB cable
3. 12V, 1A power supply
4. USB to I²C/SMBus/PMBus Controller, DC1613

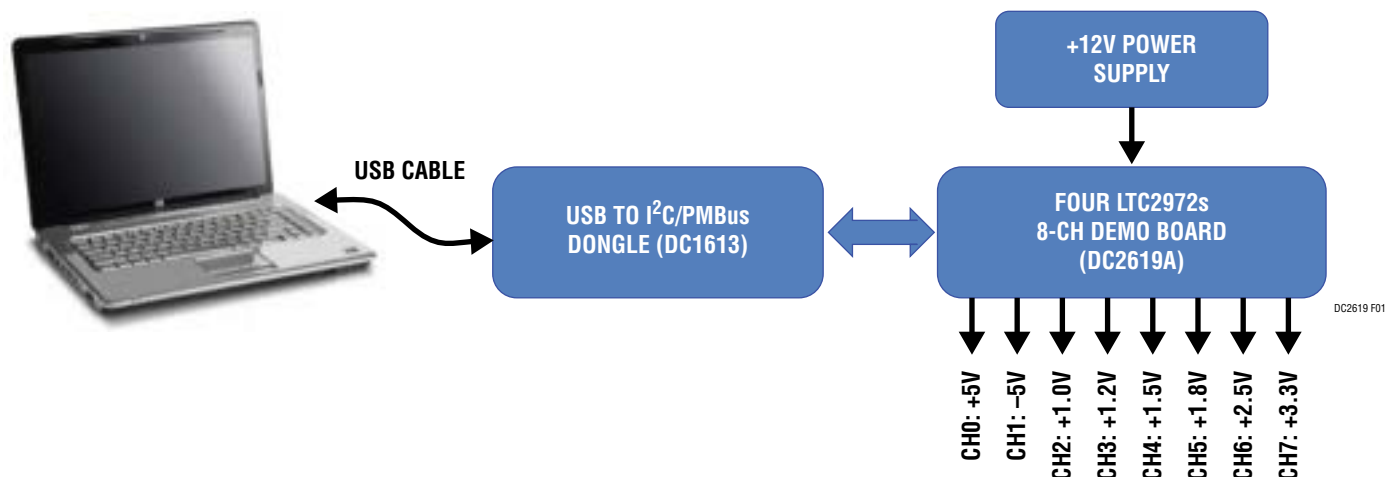

Figure 1. DC2619A Demo Setup

LTpowerPlay GUI SOFTWARE

LTpowerPlay is a powerful Windows-based development environment that supports Analog Devices power system management ICs with EEPROM, including the LTC2972 dual channel power system manager. The software supports a variety of different tasks. You can use LTpowerPlay to evaluate Analog Devices ICs by connecting to a demo board system. LTpowerPlay features an offline mode to build a multi-chip configuration file for later use with hardware. LTpowerPlay provides unprecedented system level diagnostic and debug features. It becomes a valuable diagnostic tool during board bring-up to program or tweak

the power management scheme in a system or to diagnose power issues when bringing up rails. LTpowerPlay utilizes the DC1613 I²C/SMBus/PMBus controller to communicate with one of many potential targets, including the DC2619A demo system or a customer board. The software also provides an automatic update feature to keep the software current with the latest set of device drivers and documentation. Download the [LTpowerPlay](#) software.

Select “Help, View Online Help” from the LTpowerPlay menu to access technical documents

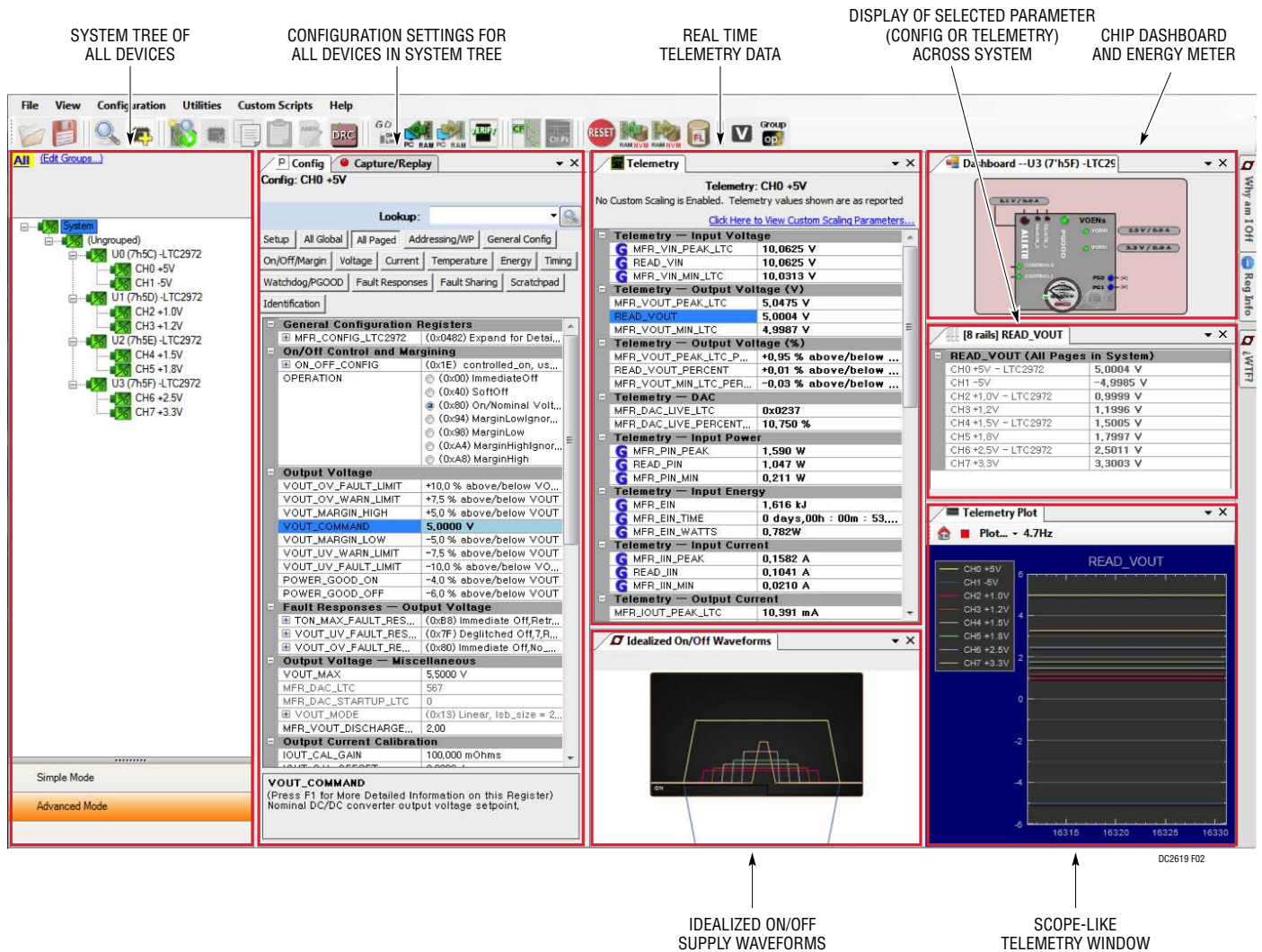

Figure 2. Screenshot of the LTpowerPlay GUI

QUICK START PROCEDURE

The following procedure describes how to set up a DC2619A demo system.

1. Download and install the [LTpowerPlay GUI](#).
2. Remove the board from the ESD protective bag and place it on a level surface. Connect the DC1613 I²C/SMBus/PMBus controller to the DC2619A board using the 12-pin ribbon cable.
3. Confirm that the CONTROL switch is set to its OFF position.
4. Plug the USB-to-I²C/SMBus/PMBus controller into a USB port on your PC. The board should power up the four LTC2972 devices by illuminating the green LEDs and the eight PG LEDs will illuminate red.
5. Connect a +12V_{DC} power supply with 1A capacity to the V_{IN} input jack of the DC2619A board. The blue LEDs will illuminate indicating that DC jack power and +5V IBV power is applied. Move the CONTROL switch to the RUN position. The eight outputs will power up and the PG LEDs will illuminate blue.

6. Launch the LTpowerPlay GUI.

- a. The GUI automatically identifies the DC2619A and builds a system tree for each I²C device. The system tree on the left hand side will look like this:

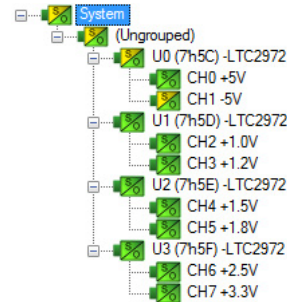

- b. A green message box will be displayed momentarily in the lower left hand corner confirming that the DC2619A is communicating.

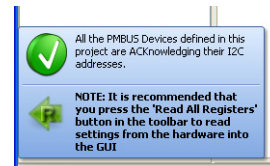
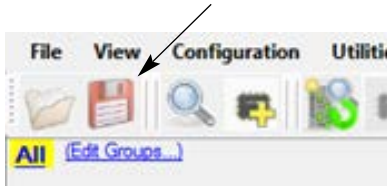

Figure 3. Connecting DC2619A and the DC1613 USB to I²C/SMBus/PMBus Controller

QUICK START PROCEDURE

c. You may make configuration changes. When you update registers in the GUI by using either function key F12 to write an individual register or use the Write All icon to write all registers, you may need these settings for future use. Save the demo board configuration to a (*.proj) file by clicking the "Save" icon. This creates a backup file on your C: drive. Name it whatever you like.



If you need to load the original board default configuration, select the GUI menu pull-down item Demo > DC2619A_Defaults. This writes the board defaults into the LTC2972's RAM and automatically to NVM as well.

7. The LTC2972 is configured to use the CONTROL switch to sequence on/off the eight channels. Slide the switch to RUN to enable, OFF to disable all channels.

Loading a Configuration (*.proj) File with the GUI

To load a previously saved proj file:

1. In the upper left hand corner of the GUI, File > Open > browse to your *.proj file. This will load the file into the GUI.

2. Click on the "Go Online"  icon, then click on the "PC->RAM" icon to write all registers.



This loads the configuration into the working RAM of the LTC2972.

3. To store the configuration to NVM (EEPROM), click on the "RAM->NVM" icon.

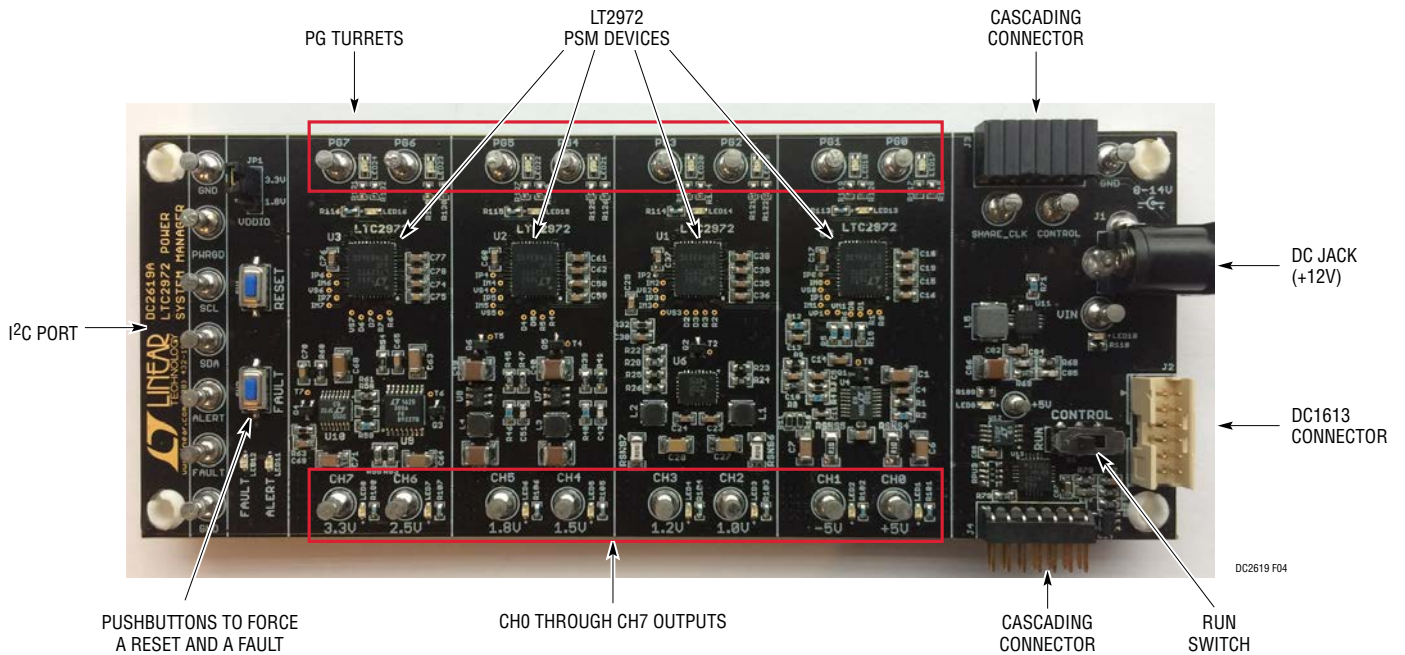

Figure 4. DC2619 Details

COMMON BOARD OPERATIONS

Overview

A simplified block diagram of the DC2619A is shown in Figure 5. The LTC2972 devices control, monitor and supervise all eight outputs. U0, U1 and U2 are powered from the DC jack. U3 is powered from the +5V intermediate bus voltage (IBV) rail. The four LTC2972 devices measure input current at various input voltage points. The current is determined by measuring the voltage drop across a 10mΩ sense resistor. Devices U2 and U3 have the ability to shut off their V_{IN} (+5V IBV) via AUXFAULT.

Powering the Board

The DC2619A board is powered from a wall-powered 12V supply. The supply must be capable of delivering 1A. If multiple channels are loaded with the maximum allowable current, the input current may exceed 1A. The LTC2972 devices are powered either from the DC1613's 3.3V power or DC jack if V_{IN} is applied. The board automatically selects the power source for the LTC2972 devices. This allows LTpowerPlay to communicate (view or change

configuration settings) with the LTC2972 devices without main board power.

DC2619A LEDs

There are two blue LEDs near the power jack. These indicate that the DC jack has voltage and the +5V switching regulator output is powered up. Each LTC2972 has a green LED that illuminates when the device is powered from either the USB controller or the external V_{IN} power. Each channel has a green LED which indicates that the channel is enabled. The red LEDs on ALERT and FAULT indicate a warning or fault has occurred. The red-blue LEDs next to each of the PG turrets indicate the logic level of the PG pin. Logic high = blue, logic low = red.

Reset the LTC2972

To reset all LTC2972 devices and reload the EEPROM contents into operating memory (RAM), press the pushbutton switch labeled RESET. If you have overwritten the contents of the EEPROM, load the demo board default configuration

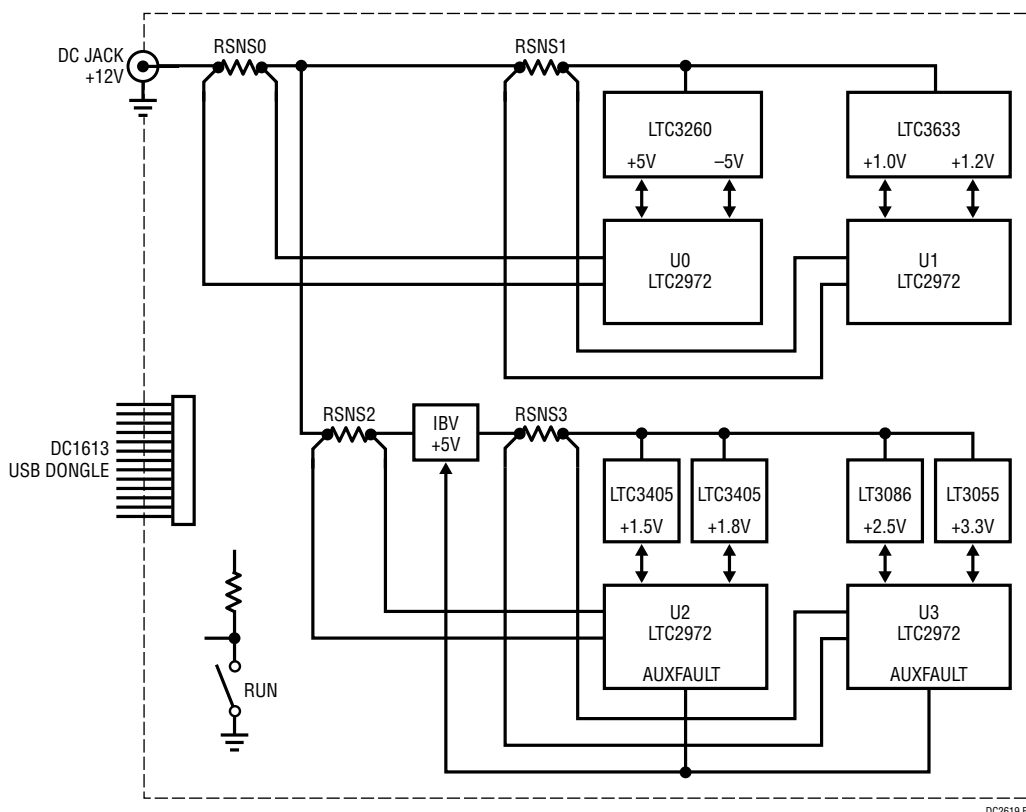

Figure 5. DC2619 Details

COMMON BOARD OPERATIONS

by selecting the GUI menu item Demo > DC2619A_Defaults to restore the settings back to factory defaults.

1.8V Logic Levels Using VDDIO

The LTC2972 can natively level translate digital signals to a low voltage I/O bus typically found on CPUs, FPGAs and ASICs. The DC2619 demonstrates this with the VDDIO jumper. With the jumper set to the 1.8V option, the PWRGD, SCL, SDA, ALERT and FAULT turrets will drive to 1.8V logic levels. The VDDIO pin on the LTC2972 acts as the reference voltage against which the digital logic pins are compared.

Pre-Load the Outputs

Each of the outputs has pre-load resistors that provide 5mA to 10mA of load. This ensures that the output voltage decays to GND quickly when the channel is disabled. This is useful when sequencing off then on quickly.

Sequencing Output Channels

The LTC2972 are pre-configured with different TON_DELAY values for each channel. The TON_DELAY parameter is applied to each of the channels relative to the CONTROL pin. On this demo board, all CONTROL pins are wire ORed. Therefore the TON and TOFF delays are enforced relative to one edge.

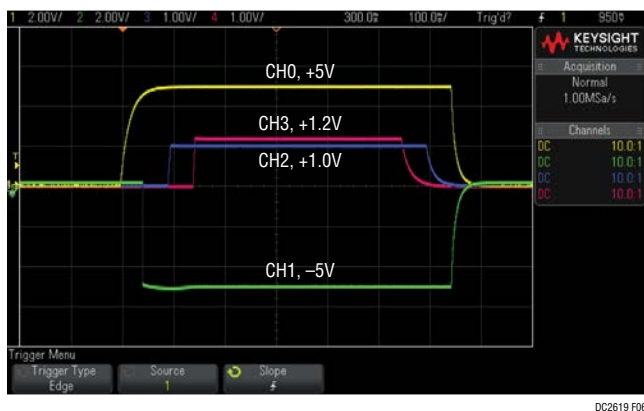

Figure 6. Sequencing Output Channels On/Off

The same applies to TOFF_DELAY values. When the CONTROL switch is set to the OFF position, all rails will power down sequentially based on the devices' TOFF_DELAY values. Figure 6 shows an oscilloscope screen capture of four output rails sequencing up and down.

Each channel has an LED which visually indicates if the channel has power. When the CONTROL pin is switched on and off, you will observe the relative on/off timing of the eight channels. The timings are intentionally skewed to show the rails on/off times more clearly. The GUI shows idealized on/off waveforms (see Figure 2). This graphical view shows the relative TON and TOFF delays in response to an on/off command, whether it comes from the CONTROL switch or PMBus command.

TON_DELAY (All Pages in System)		TOFF_DELAY (All Pages in System)	
CH0 +5V - LTC2972	0,000 ms	CH0 +5V - LTC2972	300,000 ms
CH1 -5V - LTC2972	50,000 ms	CH1 -5V - LTC2972	300,000 ms
CH2 +1,0V - LTC2972	100,000 ms	CH2 +1,0V - LTC2972	250,000 ms
CH3 +1,2V - LTC2972	150,000 ms	CH3 +1,2V - LTC2972	200,000 ms
CH4 +1,5V - LTC2972	200,000 ms	CH4 +1,5V - LTC2972	150,000 ms
CH5 +1,8V - LTC2972	250,000 ms	CH5 +1,8V - LTC2972	100,000 ms

DC2619 F07

Figure 7. TON_DELAY and TOFF_DELAY Settings

For the LTC2972, the TON_DELAY and TOFF_DELAY values extend to 13.1 seconds, providing a wide range for sequencing power supply rails.

Margin All Rails

The LTC2972 power system managers on the DC2619A not only monitor the eight outputs, but can margin the outputs either high or low. Margining is an operation that moves a rail up or down for testing purposes. It allows a system to be fully characterized over supply limits without the use of external hardware or resources. The GUI provides an easy way to margin all rails high or all low by clicking one of four buttons. To invoke the margining dialog, click the GroupOp icon in the toolbar. The buttons labeled "ignore faults" will margin without creating a fault even if the fault limits are exceeded.



COMMON BOARD OPERATIONS

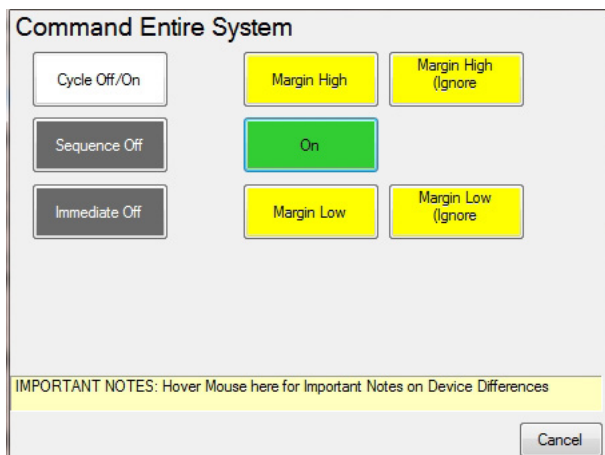

A look at the telemetry window shows the effect of the margin high or margin low operation. This screen shot is a telemetry plot of READ_VOUT_PERCENT showing all rails going from nominal set-points to margin high, margin low, and back to nominal voltages.

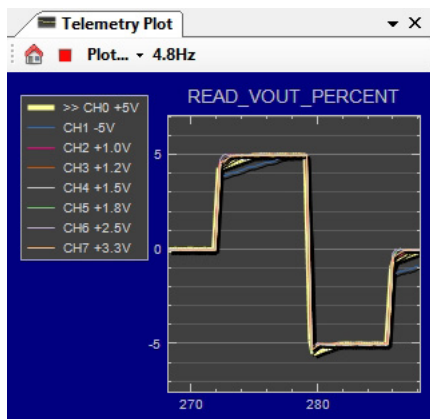

The LTC2972 has a multiplexed ADC that is used to provide voltage, current and temperature readback values. The telemetry plot in the GUI is similar to a multi-channel oscilloscope which is capable of displaying any parameter that is displayed in the telemetry window. Due to the nature of a multiplexed ADC converter, it has an associated ADC loop time of approximately 135ms.

IMON Feature

The LTC2972 has a feature for output current measurement that allows the direct connection of the I_{SENSE} pins to a regulator's IMON pin. The IMON pin allows a lossless method for measuring output current. It is 'lossless' because there is no sense resistor in the output path and therefore no IR drop between the regulator's output and the load. This is demonstrated on CH6 and CH7.

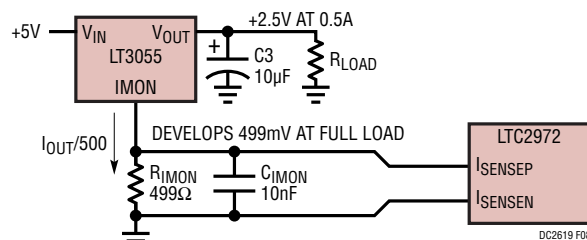

When the LTC2972 *imon_sense* configuration bit is set, this allows up to 6V to be applied differentially to the I_{SENSE} pins. The linear regulators on these channels have an IMON pin that only needs a single resistor to convert the IMON current to a single-ended voltage. This resistor can have a smaller footprint as opposed to the larger shunt resistor, saving board space. The IMON output represents a fraction of the actual output current. An optional capacitor provides noise filtering. The I_{SENSE} pins are wired across the IMON resistor. There are two configuration registers to change in the LTC2972. The first is MFR_CONFIG_LTC2972 and the bit to set is called *imon_sense*.

RESERVED9	<input type="checkbox"/> 0x0 (Reserved)
imon_sense	<input checked="" type="checkbox"/> 0x1 (imon buffered...)
servo_continuous	<input checked="" type="checkbox"/> 0x1 (Continuously ...)
servo_on_warm	<input type="checkbox"/> 0x0 (No MPT allow)

The other register is IOUT_CAL_GAIN. This sets the equivalent resistance in milliohms and must be set to $R_{IMON}/(I_{OUT}/I_{MON})$. In the example shown, the I_{OUT}/I_{MON} ratio of the LT3055 is 500. IOUT_CAL_GAIN should be set to $499\Omega/500 = 0.998\Omega$ or 998 milliohms.

Output Current Calibration	
IOUT_CAL_GAIN	998.000 mOhms
IOUT_CAL_OFFSET	0.0000 A

The READ_IOUT register will then read back the correct output current in units of Amps.

COMMON BOARD OPERATIONS

Programmable PG Pins

The LTC2972 brings new functionality to the LTC297x PSM family. The LTC2972 has a PWRGD pin and two PG pins. The PWRGD pin has the same functionality as previous devices in the family. It releases when all channels (as configured) report their V_{OUT} voltage rises above the POWER_GOOD_ON threshold. Whereas the PWRGD pin is driven from ADC results, the new PG pins respond to comparator-based circuits resulting in faster signal assertion. The PG pins are also more configurable, similar to GPIO pins. They can be used to assert upon any combination of V_{OUT} OV/UV, V_{IN} OV/UV, OT/UT and TON_MAX_FAULT, or controlled via PMBus commands.

MFR_WATCHDOG_T_LTC		0,000 ms
Power Good		
<input checked="" type="checkbox"/>	MFR_PWRGD_EN_LTC2...	(0x003) chan1,chan0
<input checked="" type="checkbox"/>	MFR_POWERGOOD_ASS...	100,000 ms
PG Pins		
<input checked="" type="checkbox"/>	MFR_PG_CONFIG	(0xC046) Expand for Detail...
<input checked="" type="checkbox"/>	MFR_PG_GPO	(0x00) PG forced low

The V_{OUT} OV/UV has an optional deglitch time that may be added to the assertion time. A PG pin may be used solely as a hardware pin that pulls low upon an overtemperature or V_{IN} UV condition. The DC2619 board has a red-blue LED next to each of the PG turrets. Blue indicates the PG pin is a logic high level and red indicates a logic low level.



The scope shot shows V_{OUT} CH2, PG2, and PWRGD signals with infinite persistence. Multiple triggers show that PG asserts immediately and is predictable whereas PWRGD assertions are not only slower than PG but also the timing is variable.

Creating a Fault

There is a pushbutton on the DC2619A board that is used to force a fault and demonstrate the demo board's ability to detect it and respond according to the configuration. When depressed, the FAULT pushbutton (SW2) creates a fault (shorts V_{SENSE} node to ground) on CH7, the +3.3V output. When faulted, all channels power down immediately and the GUI's system tree indicates the color red for the Status portion of that channel. You should see all outputs power off, the fault LED momentarily illuminates, the alert LED illuminate continuously, and all rails sequence back on after a retry period. You may also hold the FAULT pushbutton indefinitely to demonstrate the retry timing to a persistent fault.

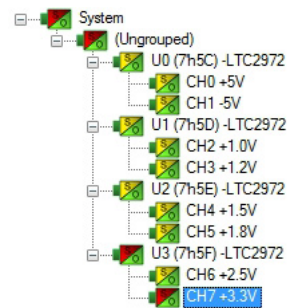

Clearing a Fault



To clear a fault, the user can click the CF icon in the GUI or simply push the RESET pushbutton (SW1) on the DC2619A demo board. In both cases, the red (+) on the CF icon and alert LED on the board are both cleared. Notice that all rails are automatically re-enabled after a programmable retry period. A dialog box may pop up after clicking the Clear Faults (CF) icon. If a fault log is present, a dialog will ask if you would like to clear the fault log as well as clear system faults. After clearing faults, the system tree will return to green and fault logs re-armed.

For further information, see the Working with the Fault Log section.

“Why Am I Off?” Tool

Use the “Why am I Off” tool in the LTpowerPlay GUI to diagnose the cause for a power supply channel being in an off state. The tool is located in the top right corner of the GUI, above the “Register Information” tab. Hover your cursor over the tab to show the tool.

First select an output channel in the system tree. The tool collects various status information and provides a diagnosis.

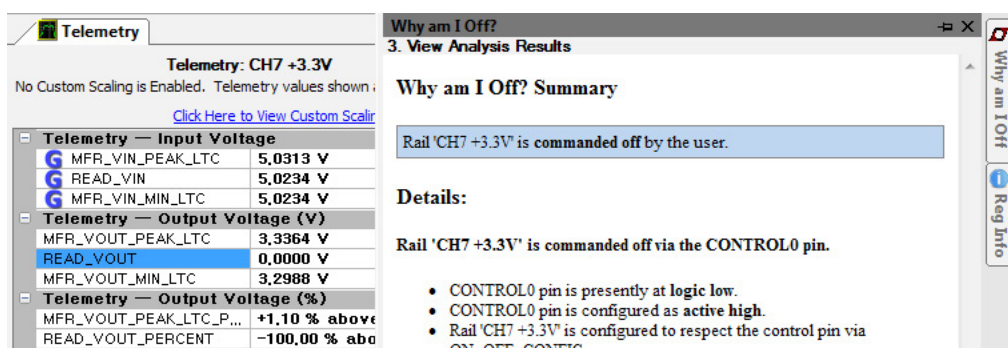

Figure 8. “Why Am I Off” Tool in the LTpowerPlay GUI

ADVANCED DEMO BOARD OPERATIONS

What Is a Fault Log?

A fault log is a nonvolatile record of the power system leading up to the time of fault. Telemetry data is continuously updated in a circular RAM buffer in the LTC2972. When a fault occurs, the contents of the RAM buffer are automatically written to NVM. The most recent monitored values (uptime, voltage, current, temperature) provide additional context preceding the fault. It is a powerful diagnostic feature of the LTC2972 on the DC2619A demo board.

Create a Fault Log

To create a fault log, check that the `fault_log_enable` bit is set in the `MFR_CONFIG_ALL` register. Then, create a fault, as described in the section [Creating a Fault](#). If multiple boards are configured, select the appropriate device in the system tree by clicking on the appropriate LTC2972 chip, in this case U3. We are ready to work with the fault log.

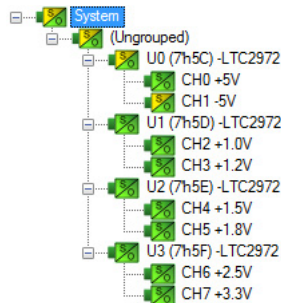

Working with the Fault Log

Once a fault has occurred, the Fault Log (FL) icon will show a red (+) sign on it, indicating that the GUI has detected a fault log in the device.

Clicking the icon will bring up a dialog box. Note that it is a context sensitive icon. If multiple DC2619A boards are connected, be sure that the desired device is selected in the system tree. Notice that the EEPROM log is locked. The log will not change until it is cleared by the user.

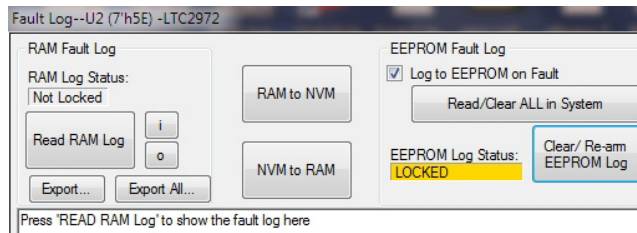

It is a 2-step process to read the fault log. First click the “NVM to RAM” button. At this point the RAM Log is locked. Click the “Read NVM Log” button. The fault log data will appear in the text box below.

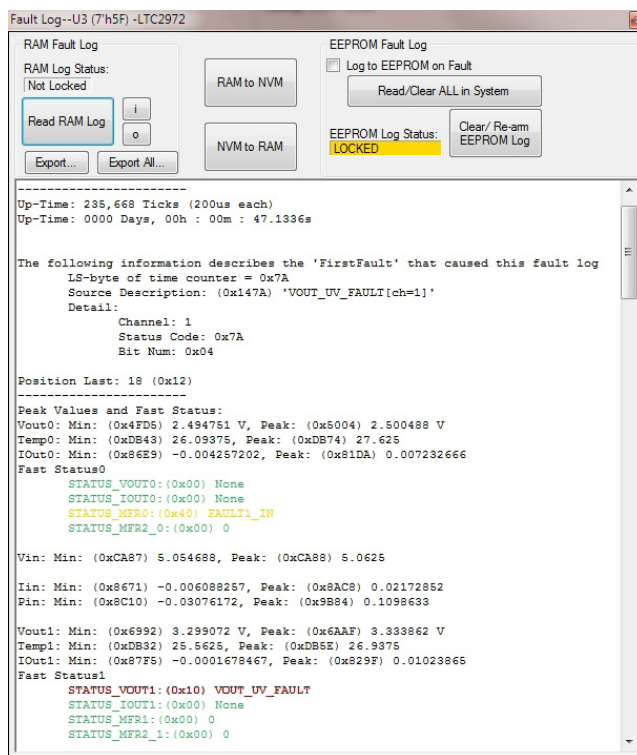

The log contains timestamp, up-time, channel voltage readings, an input voltage reading, an on-chip temperature reading, etc. There will be a number of loops; each loop contains data obtained in one ADC loop time with the most recent ADC loop data on top and the oldest data at the bottom of the log. The up-time indicates, at the time of fault, the amount of time the device had been powered up or time since the previous reset.

ADVANCED DEMO BOARD OPERATIONS

In this case, the fault log will show that CH1 of device U3 faulted due to a VOUT_UV_FAULT condition. On the previous telemetry loop, the channel voltage reading was a nominal value (+5V). You can save the fault log to a file (.rtf) by clicking the Export button.

To clear the fault log, click the “Clear/Rearm EEPROM Log” button. This allows the selected device to be ready for a new fault event. To clear all faults, click the Clear Faults (CF) icon.

Fault Sharing Setup in the GUI

Fault sharing provides a means of propagating a fault detected by a power manager to other power managers via FAULT pins. Use the Fault Sharing Setup Tool to configure the fault sharing in the GUI. Select U3 in the system tree. Go to Utilities > Fault Sharing Diagram. For more details on this topic, please refer to the Fault Management section in the data sheet.

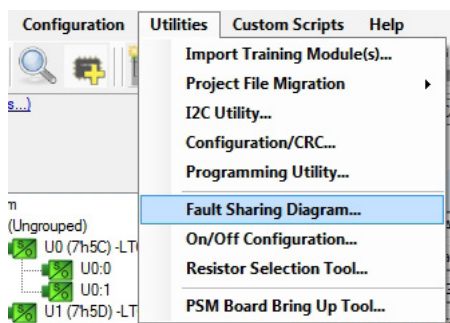

There are two types of actions to fault conditions: How a channel responds to another channel’s fault and whether a particular channel propagates its fault to other channels. FAULT pins are bidirectional, meaning the device may drive its fault pin low (output) or may respond to the fault pin when another device drives it low (input). By default, the LTC2972 is configured to shut down channels if the FAULT pin is low and to propagate its own fault to the other channels by driving both FAULT pins low. You can think of the “Response” switches as “shut this channel down” when another channel faults, and the “Propagate” switches as “drive the fault pin” to broadcast to other channels that this channel faulted.

On the DC2619A, the two FAULT pins are separated, which creates two fault zones. This allows us to demonstrate various fault management scenarios. The fault sharing dialog will appear as shown in Figure 9. By default, the FAULTB0 Response and Propagate switches are closed on devices U0 and U1. Similarly the FAULTB1 Response and Propagate switches are closed on devices U2 and U3. This creates two fault zones. In this configuration, a fault on a channel will shut down the channels in that zone.

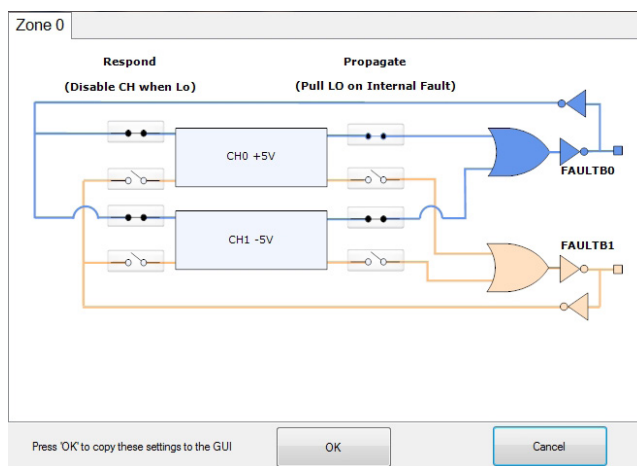

Figure 9. Fault Sharing Utility in LTPowerPlay GUI

For example if you short CH0’s output to GND, CH0 through CH3 will shut off because CH0 is propagating its fault via the FAULTB0 pin which we will call zone 0. CH1 through CH3 will respond to FAULTB0 being asserted. You may use a coin or a jumper to temporarily connect an output to the GND turret.

Likewise, if you short the CH4’s output to GND, CH4 through CH7 will shut off because CH4 is propagating its fault via the FAULTB1 pin and CH5 through CH7 are responding to FAULTB1 or zone 1. In this configuration, a fault on a channel will shut down not only the faulted channel but all other channels within that zone.

NOTE: The FAULT turret is not tied directly to the FAULTB pins of the PSM devices. The turret is a logic gate output that drives the fault LED. Therefore the user cannot expect to create a fault-in condition by pulling the turret low. This will only illuminate the LED.

ADVANCED DEMO BOARD OPERATIONS

Fault Configuration Examples

Let's explore other scenarios. Suppose we want channel CH0 (+5V) and CH1 (-5V) to shut down in response to a fault in zone 1. CH0 and CH1 can be configured to respond to the FAULT1 zone by closing the Respond switches that correspond to FAULT1. Simply click the switches to open/close. Click the "PC->RAM" icon to write the changes to the LTC2972.

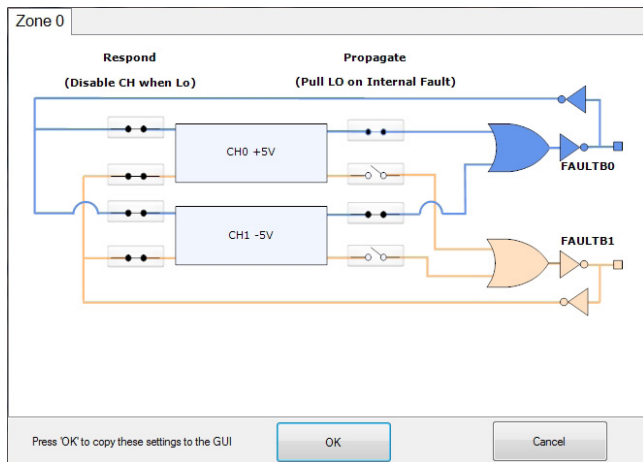

Figure 10. Updated Fault Sharing Configuration

We can now create a fault on CH7 by pressing the FAULT pushbutton. This creates a fault in zone 1 which channels 0 and 1 are now listening to.

Another scenario is one in which a channel that does not participate in responding to or propagating a fault. To demonstrate this, select CH4 and open the fault switches. Remember to click the "Write to RAM" icon. When you short any of the other channels, the faulted channel and other channels in that zone will shut off but CH4 remains powered. After the retry period, the channels participating in the fault zones will power back up. If you short CH4, this channel will shut down and other channels are unaffected. This is an example of a keep-alive channel that remains powered up independent of faults to other channels.

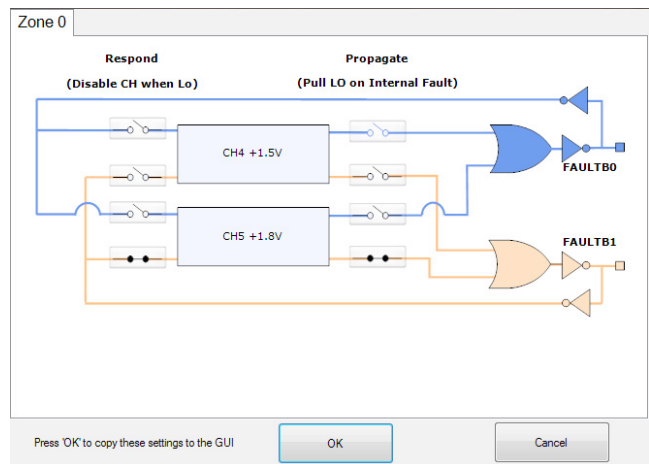

Figure 11. CH4 Fault Switches Open

Energy Metering

The LTC2972 is capable of high-side current sensing of an input power supply. This feature allows the manager to measure input supply current. The DC2619A demonstrates four different input supply current readings. Refer to the block diagram shown in Figure 5 for the location of each sense element. Select the READ_IIN register to display the telemetry plot for all input currents. The input current reading for U0 will be ~45mA if all channels are enabled and V_{IN} is 12V. Notice the current readings go to zero when the channels are off.

The manager also measures input supply voltage and is therefore able to report input power as well. Since energy is the product of power and time, accumulated energy is provided based on the manager's internal timebase.

The meter displayed in the upper right hand corner of the GUI provides a number of bits of information. The needle is a real-time indicator of input power and the smaller five dials show the total accumulated energy similar to a home electricity meter. Digital readouts are also provided for convenience.

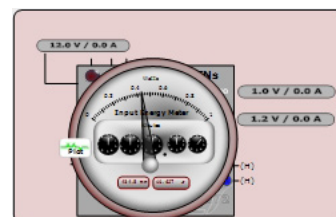

ADVANCED DEMO BOARD OPERATIONS

The four LTC2972 devices on the DC2619A monitor and measure eight output supplies and four input power supplies, both voltage and current. LTpowerPlay offers a simple and easy to understand interface that brings together input and output current, voltage, power and energy readings.

You may also view the input current, input voltage, input power and input energy together in tabular format. These appear in the telemetry portion of the GUI. The MFR_EIN register holds the accumulated energy value in millijoules. There is also a total time that the energy accumulator has been active and is shown as the MFR_EIN_TIME register. The GUI will automatically update the displayed SI prefix as the units change from mJ to J to kJ.

Telemetry — Input Power	
MFR_PIN_PEAK	0.599 W
READ_PIN	0.559 W
MFR_PIN_MIN	0.141 W
Telemetry — Input Energy	
MFR_EIN	55.036 J
MFR_EIN_TIME	0 days,00h : 01m : 37.812s
MFR_EIN_WATTS	0.571W
Telemetry — Input Current	
MFR_IIN_PEAK	0.0490 A
READ_IIN	0.0465 A
MFR_IIN_MIN	0.0113 A

To demonstrate the meter readings and register values, first select the MFR_EIN register to display the energy in the telemetry plot. To display the plot as shown here, simply press the RESET pushbutton. This resets the energy accumulators. The accumulated energy rate is the slope. Note that the input current and input power on U0 and U1 are higher than U2 and U3, and therefore energy is accumulated at a higher rate. The MFR_EIN_WATTS register displays the input power that is being drawn. This register is the product of the READ_VIN and

READ_IIN values. Since the input voltage is 12V, U0's input power is $12V \cdot 45mA$ or $\sim 0.54W$. You can confirm this by clicking these three registers one by one and view the telemetry window.

The MFR_EIN and MFR_EIN_TIME registers may be reset by right-clicking the MFR_EIN register which displays an option menu to "Clear HW Register". It may also be reset by writing the MFR_EIN_CONFIG register.

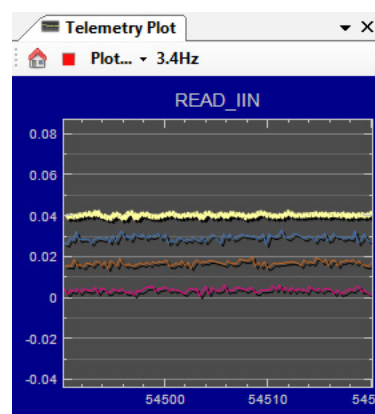
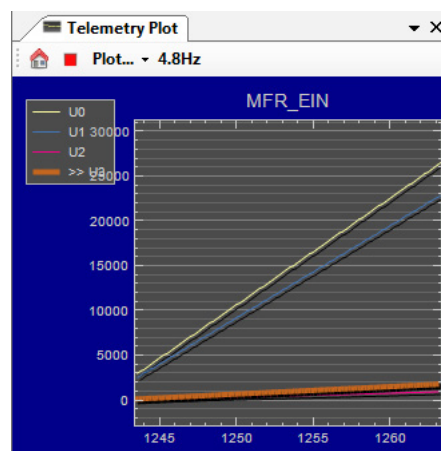

SETUP PROCEDURE FOR MULTI-BOARD ARRAYS

Multiple demo boards that have the 14-pin cascading connectors can be combined to control as many eight boards. Demo boards that can be cascaded include the DC2619, DC1962, DC2022, DC2023, DC2028, DC2198 and DC2518. The number of boards is limited by an I/O expander chip that has three address pins, allowing 8 different combinations. This setup demonstrates the coordinated fault responses and accurate time base shared across multiple power system managers.

Procedure:

1. Stack the boards side-by-side by plugging JP3 of one board into JP4 of another DC2619A board.
2. Ensure different slave address settings for each of the boards. The address of each DC2619A board is set by the DIP switch JP2 on the backside of the board. The setting must be unique for each board in the array.
3. Plug in the +12V V_{IN} power into one of the boards as shown in Figure 12 below. Only one +12V power source is allowed.
4. The USB-to-I²C/SMBus/PMBus controller may be plugged into any board. If no demo boards show up in the GUI, click the magnifying glass icon to enumerate the I²C bus and find the addresses of the parts. Go to step #2 to ensure that each board has a unique DIP switch setting.
5. Since the individual CONTROL lines are connected across the boards (CTRL is a common signal across all boards in the array), make sure that all CONTROL switches are set to the RUN position.
6. Re-launch LTpowerPlay. After launching, LTpowerPlay will enumerate the entire board array and build a representative system tree and read all hardware settings into the GUI.

ATTENTION: Once the GUI has launched, click the "RAM->NVM" button in the toolbar to ensure that the slave addresses are retained after a power off or reset. Otherwise you may lose communication with the slaves after a power cycle or reset event.

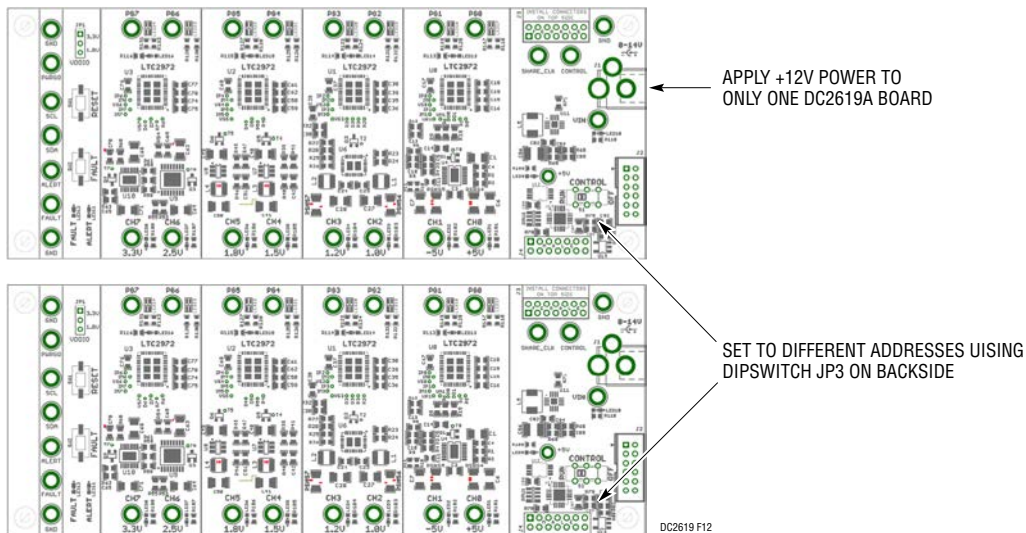

Figure 12. Array of Multiple Board Sets

SETUP PROCEDURE FOR MULTI-BOARD ARRAYS

Ensuring Slave Addresses Do Not Conflict

There is a small DIP switch on the backside of the DC2619A. It is used to set the slave address of an I/O expander which allows the addition of multiple boards to

a setup. The I/O expander has a base address of 0x20. The DIP switch settings set the offset. The three switches that may be changed are labeled A0, A1, A2. Examples below set the boards to address 0x20 and 0x27.

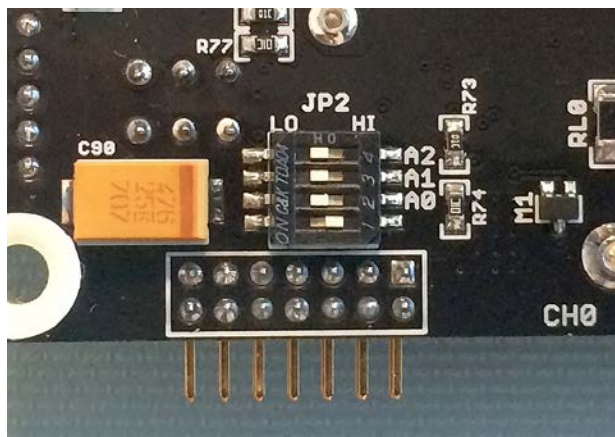

Figure 13. DIP Switch Set to All 0's

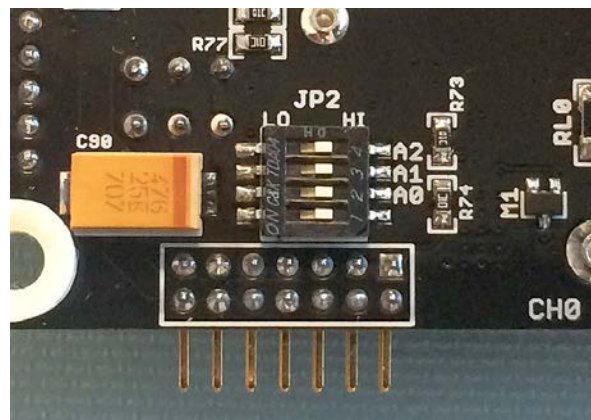

Figure 14. DIP Switch Set to All 1's

DEMO MANUAL DC2619A

DC2619A DETAILS TOP

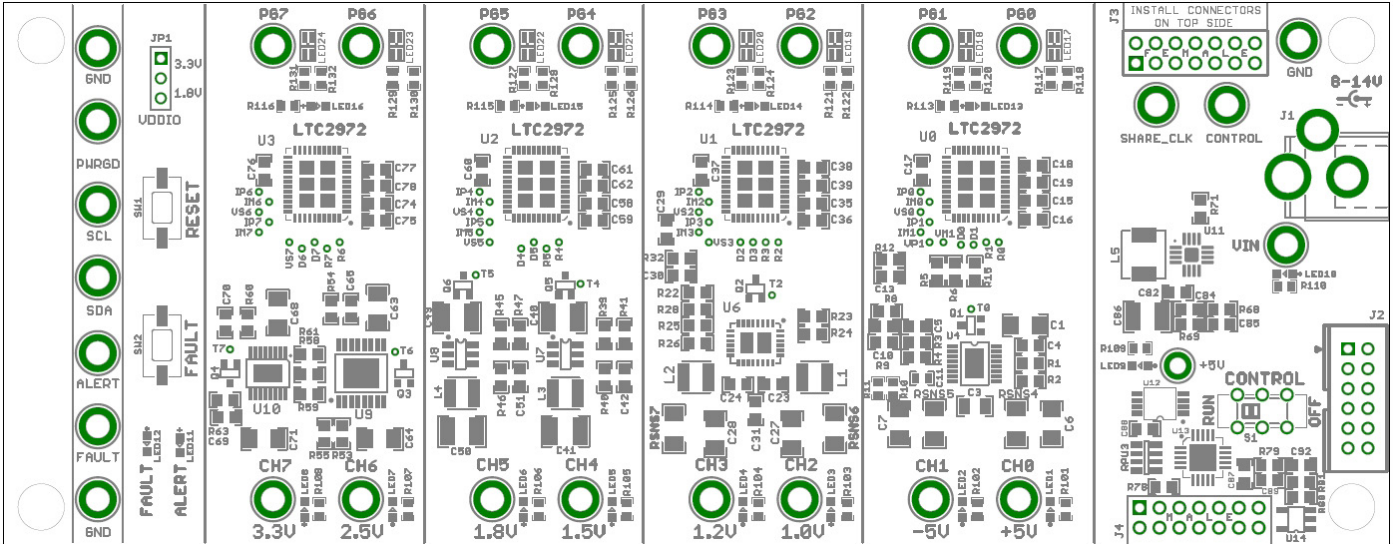
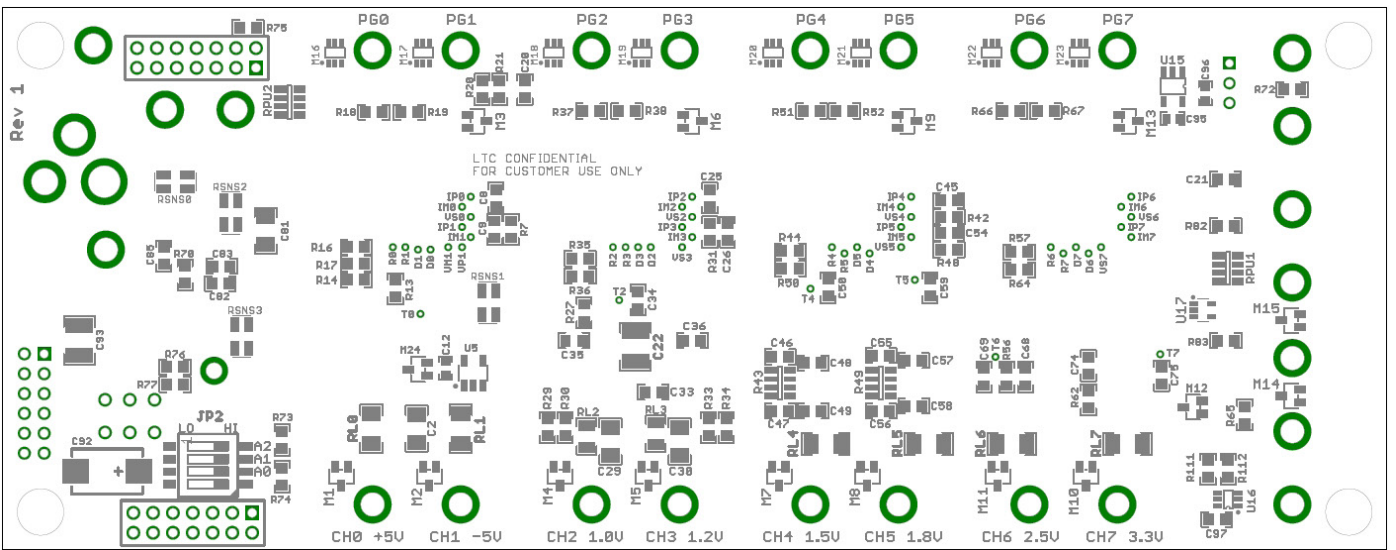

Table 2. DC2619A Default Switch Configuration

REFERENCE DESIGNATOR	SIGNAL NAME	USAGE	DEFAULT
JP1 (top)	VDDIO	Set to 3.3V or 1.8V I/O Levels	3.3V
JP2 (bottom)	A0, A1, A2	DIP Switch Used to Set the Address Offset	OPEN
S1	CTRL	Switch Used to Enable/Disable Channels by Pulling the CONTROL Input Pins High/Low of LTC2972	RUN

DC2619A DETAILS BOTTOM



SCHEMATIC DIAGRAM

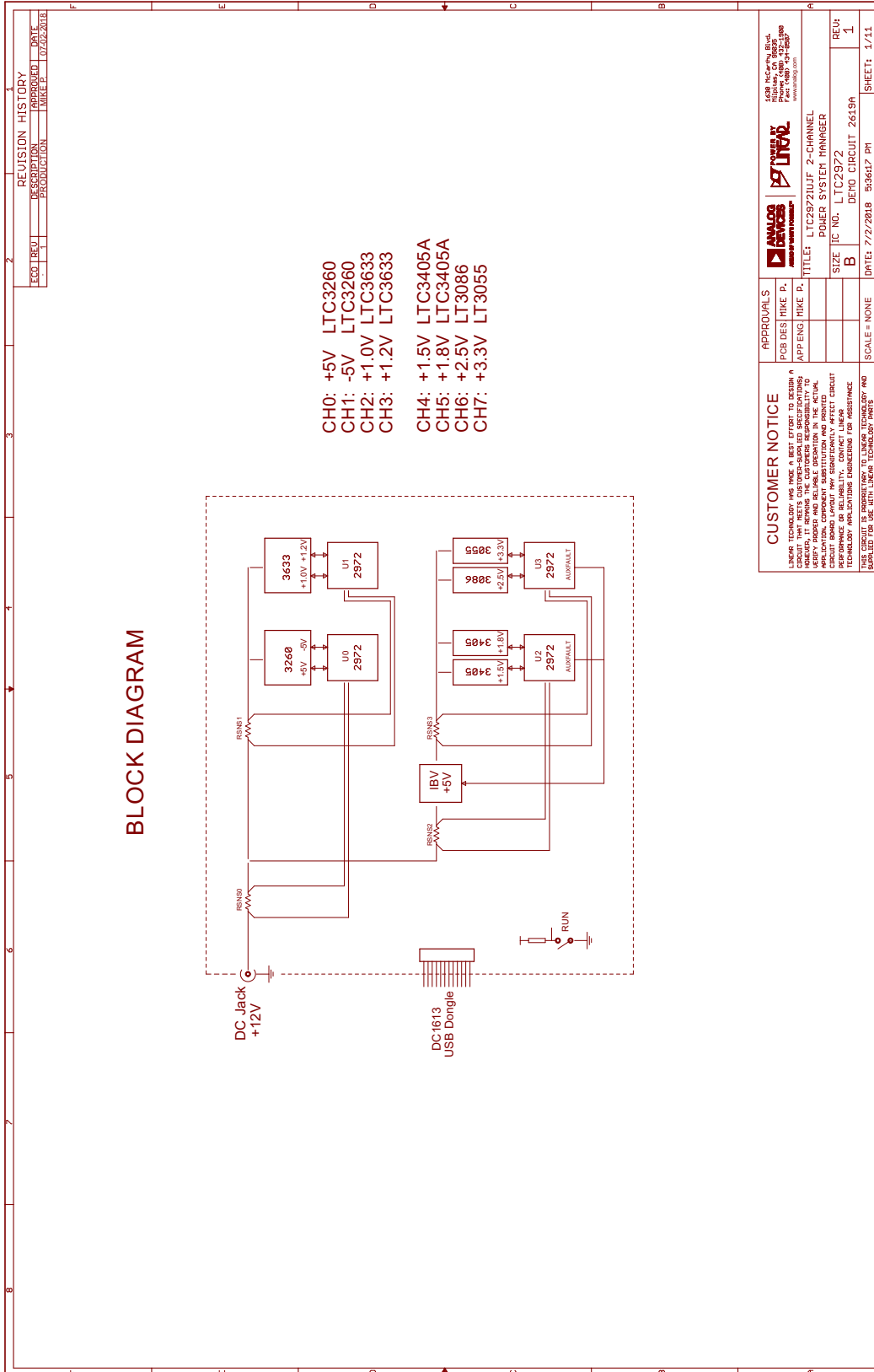

SCHEMATIC DIAGRAM

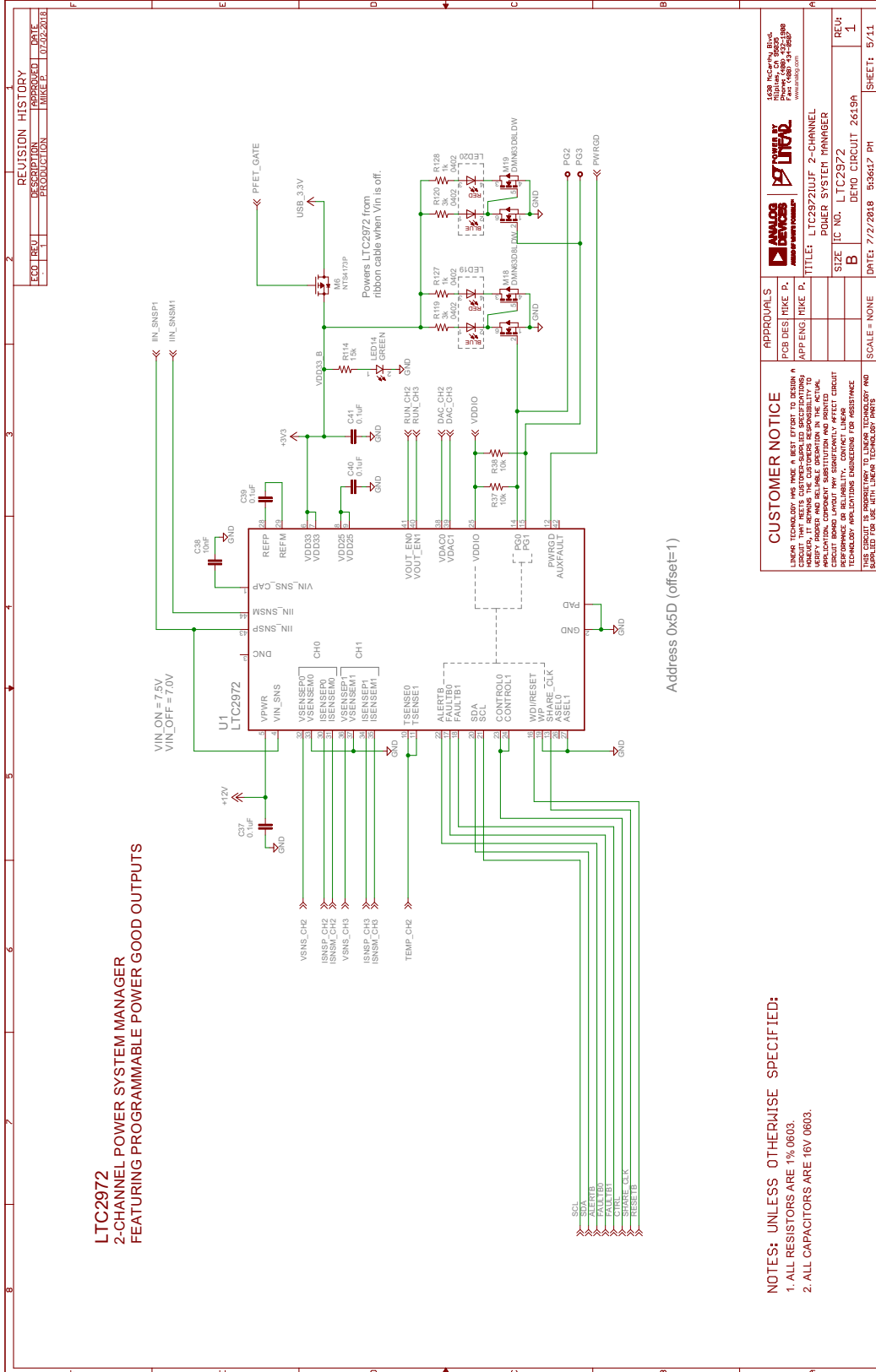

DEMO MANUAL DC2619A

SCHEMATIC DIAGRAM

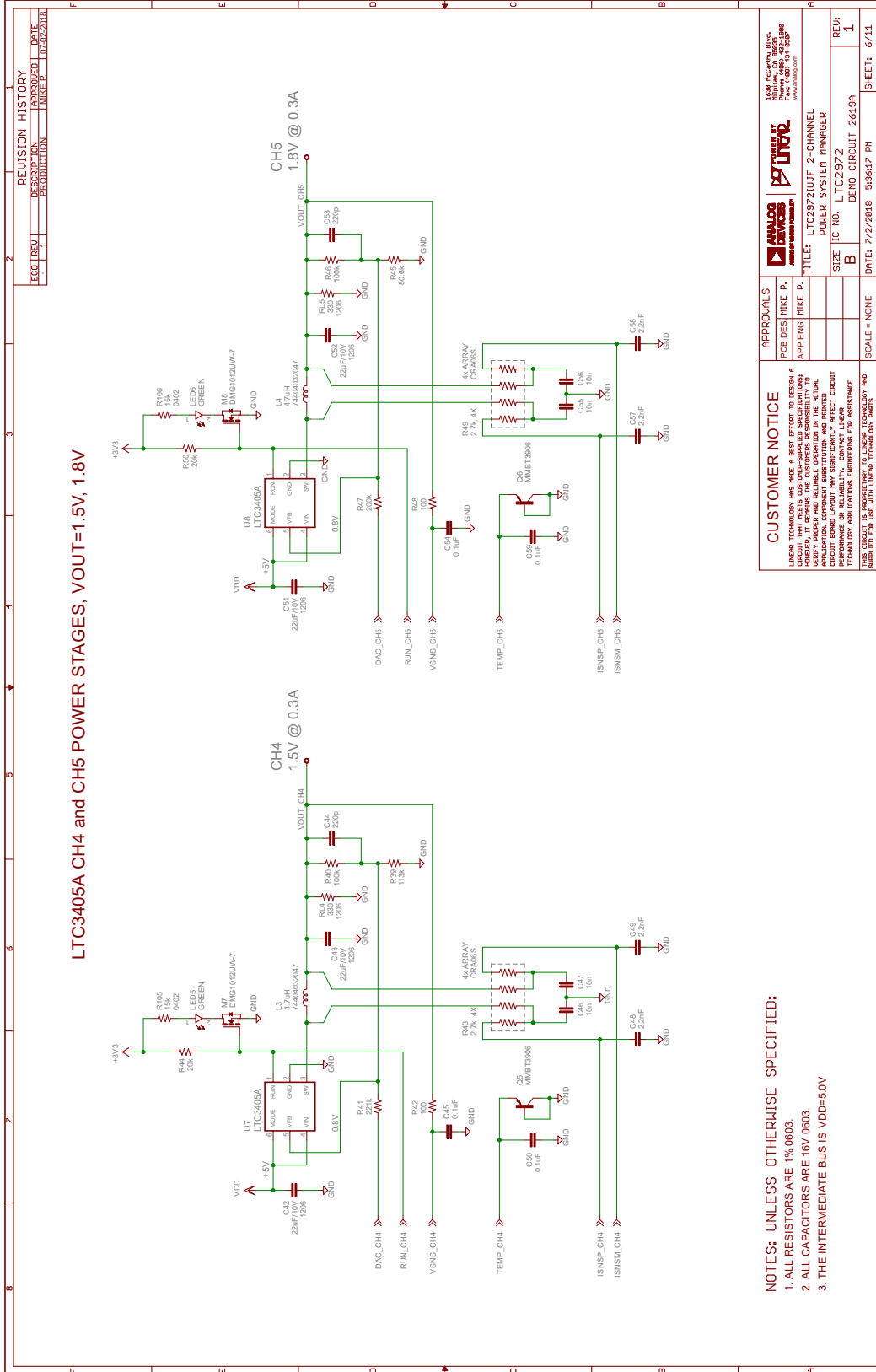

SCHEMATIC DIAGRAM

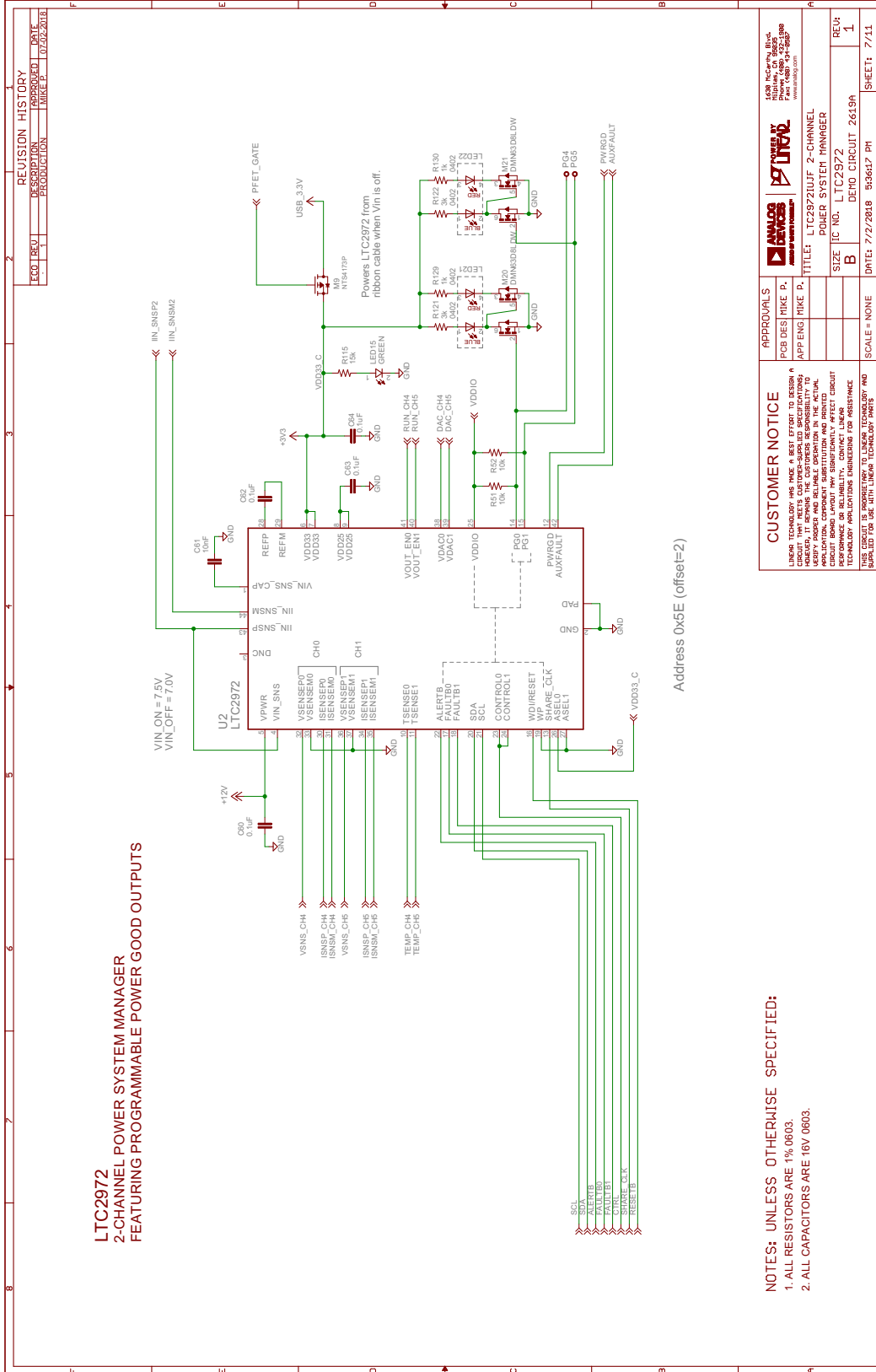

SCHEMATIC DIAGRAM

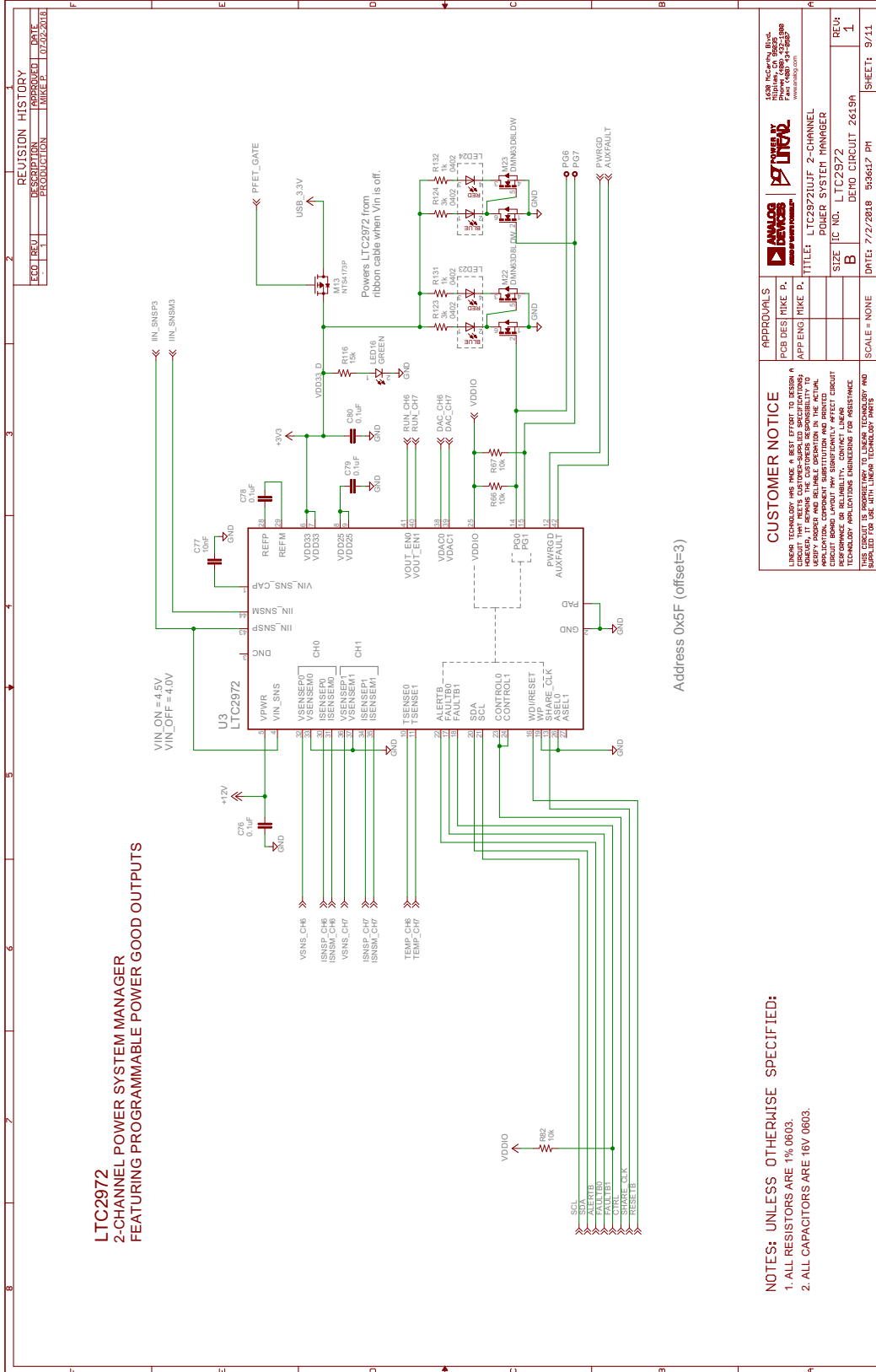

NOTES: UNLESS OTHERWISE SPECIFIED:
1. ALL RESISTORS ARE 1% 0803.
2. ALL CAPACITORS ARE 16V 0803.

Address 0x5F (offset=3)

REV	DESCRIPTION	DATE
1.00	DRU	10/20/2018
1.01	PRODUCTION	10/20/2018

REVISION HISTORY
APPROVED
DATE

APPROVALS	CUSTOMER NOTICE										
<table border="1"> <tr> <td>DESIGN</td> <td>MIKE P.</td> </tr> <tr> <td>APP'G</td> <td>MIKE P.</td> </tr> </table>	DESIGN	MIKE P.	APP'G	MIKE P.	<p>LINEMAR TECHNOLOGY HAS MADE A BEST EFFORT TO DESIGN A BOARD THAT MEETS CUSTOMERS NEEDS AND SPECIFICATIONS. HOWEVER, IT IS THE CUSTOMERS RESPONSIBILITY TO VERIFY THE BOARD IS ASSEMBLED AND OPERATES AS INTENDED. CUSTOMERS SHOULD VERIFY PROPER AND RELIABLE OPERATION IN THE ACTUAL APPLICATION. CUSTOMERS SHOULD VERIFY THE BOARD LAYOUT HAS NO SIGNIFICANTLY AFFECT CIRCUIT PERFORMANCE OR RELIABILITY. CONTACT LINEMAR TECHNOLOGY APPLICATIONS ENGINEERS FOR ASSISTANCE. BOARD LAYOUT FOR USE WITH LINEMAR TECHNOLOGY PARTS.</p>						
DESIGN	MIKE P.										
APP'G	MIKE P.										
<table border="1"> <tr> <td>TITLE</td> <td>LTC2972UIF 2-CHANNEL POWER SYSTEM MANAGER</td> </tr> <tr> <td>SIZE</td> <td>IC No. LTC2972</td> </tr> </table>	TITLE	LTC2972UIF 2-CHANNEL POWER SYSTEM MANAGER	SIZE	IC No. LTC2972	<table border="1"> <tr> <td>SCALE</td> <td>NONE</td> </tr> <tr> <td>DATE</td> <td>7/2/2018</td> </tr> <tr> <td>DESIGNER</td> <td>593647 PH</td> </tr> </table>	SCALE	NONE	DATE	7/2/2018	DESIGNER	593647 PH
TITLE	LTC2972UIF 2-CHANNEL POWER SYSTEM MANAGER										
SIZE	IC No. LTC2972										
SCALE	NONE										
DATE	7/2/2018										
DESIGNER	593647 PH										

APPROVALS	CUSTOMER NOTICE										
<table border="1"> <tr> <td>DESIGN</td> <td>MIKE P.</td> </tr> <tr> <td>APP'G</td> <td>MIKE P.</td> </tr> </table>	DESIGN	MIKE P.	APP'G	MIKE P.	<p>LINEMAR TECHNOLOGY HAS MADE A BEST EFFORT TO DESIGN A BOARD THAT MEETS CUSTOMERS NEEDS AND SPECIFICATIONS. HOWEVER, IT IS THE CUSTOMERS RESPONSIBILITY TO VERIFY THE BOARD IS ASSEMBLED AND OPERATES AS INTENDED. CUSTOMERS SHOULD VERIFY PROPER AND RELIABLE OPERATION IN THE ACTUAL APPLICATION. CUSTOMERS SHOULD VERIFY THE BOARD LAYOUT HAS NO SIGNIFICANTLY AFFECT CIRCUIT PERFORMANCE OR RELIABILITY. CONTACT LINEMAR TECHNOLOGY APPLICATIONS ENGINEERS FOR ASSISTANCE. BOARD LAYOUT FOR USE WITH LINEMAR TECHNOLOGY PARTS.</p>						
DESIGN	MIKE P.										
APP'G	MIKE P.										
<table border="1"> <tr> <td>TITLE</td> <td>LTC2972UIF 2-CHANNEL POWER SYSTEM MANAGER</td> </tr> <tr> <td>SIZE</td> <td>IC No. LTC2972</td> </tr> </table>	TITLE	LTC2972UIF 2-CHANNEL POWER SYSTEM MANAGER	SIZE	IC No. LTC2972	<table border="1"> <tr> <td>SCALE</td> <td>NONE</td> </tr> <tr> <td>DATE</td> <td>7/2/2018</td> </tr> <tr> <td>DESIGNER</td> <td>593647 PH</td> </tr> </table>	SCALE	NONE	DATE	7/2/2018	DESIGNER	593647 PH
TITLE	LTC2972UIF 2-CHANNEL POWER SYSTEM MANAGER										
SIZE	IC No. LTC2972										
SCALE	NONE										
DATE	7/2/2018										
DESIGNER	593647 PH										

SCHEMATIC DIAGRAM

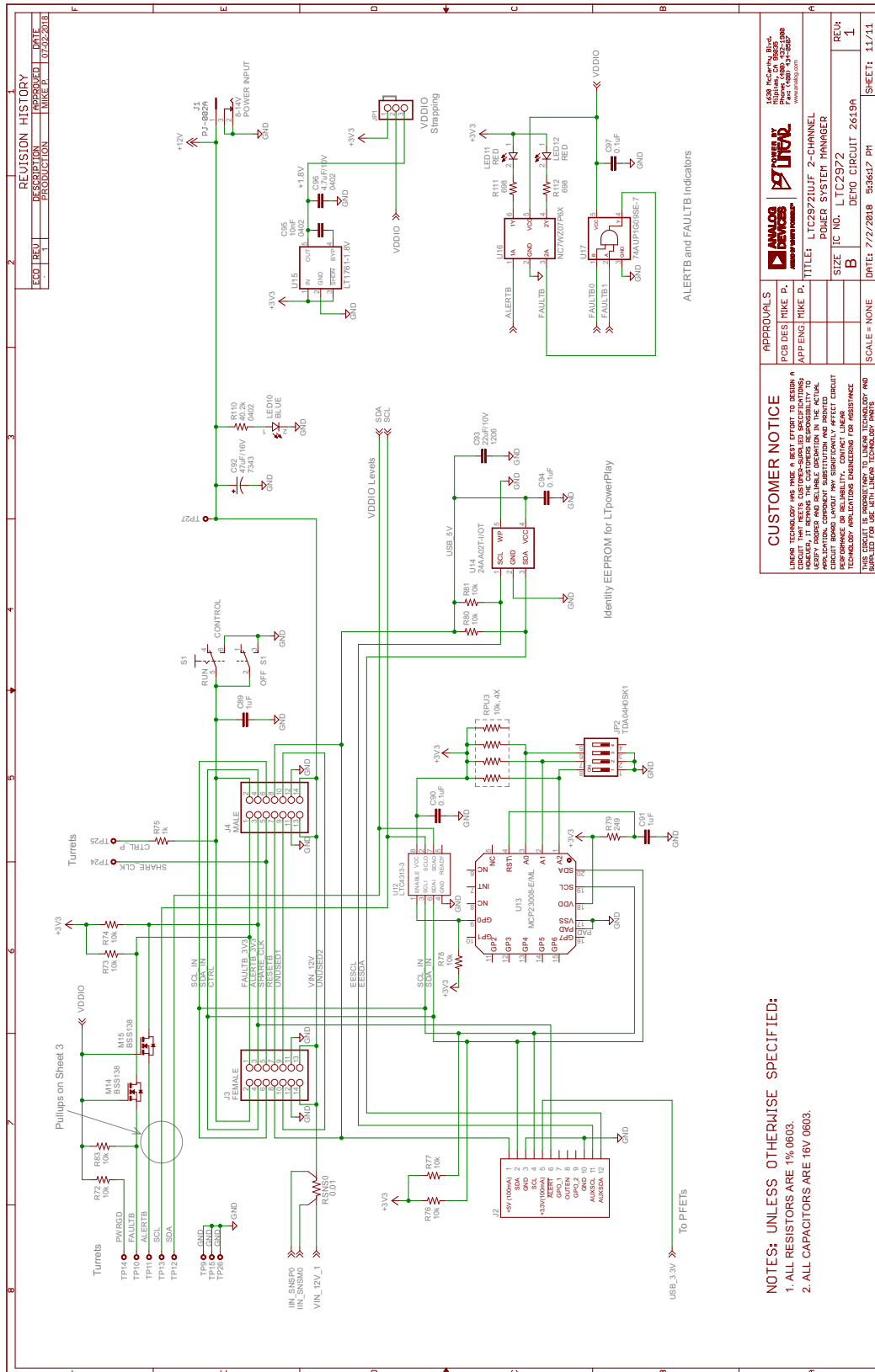



ESD Caution

ESD (electrostatic discharge) sensitive device. Charged devices and circuit boards can discharge without detection. Although this product features patented or proprietary protection circuitry, damage may occur on devices subjected to high energy ESD. Therefore, proper ESD precautions should be taken to avoid performance degradation or loss of functionality.

Legal Terms and Conditions

By using the evaluation board discussed herein (together with any tools, components documentation or support materials, the "Evaluation Board"), you are agreeing to be bound by the terms and conditions set forth below ("Agreement") unless you have purchased the Evaluation Board, in which case the Analog Devices Standard Terms and Conditions of Sale shall govern. Do not use the Evaluation Board until you have read and agreed to the Agreement. Your use of the Evaluation Board shall signify your acceptance of the Agreement. This Agreement is made by and between you ("Customer") and Analog Devices, Inc. ("ADI"), with its principal place of business at One Technology Way, Norwood, MA 02062, USA. Subject to the terms and conditions of the Agreement, ADI hereby grants to Customer a free, limited, personal, temporary, non-exclusive, non-sublicensable, non-transferable license to use the Evaluation Board FOR EVALUATION PURPOSES ONLY. Customer understands and agrees that the Evaluation Board is provided for the sole and exclusive purpose referenced above, and agrees not to use the Evaluation Board for any other purpose. Furthermore, the license granted is expressly made subject to the following additional limitations: Customer shall not (i) rent, lease, display, sell, transfer, assign, sublicense, or distribute the Evaluation Board; and (ii) permit any Third Party to access the Evaluation Board. As used herein, the term "Third Party" includes any entity other than ADI, Customer, their employees, affiliates and in-house consultants. The Evaluation Board is NOT sold to Customer; all rights not expressly granted herein, including ownership of the Evaluation Board, are reserved by ADI. CONFIDENTIALITY. This Agreement and the Evaluation Board shall all be considered the confidential and proprietary information of ADI. Customer may not disclose or transfer any portion of the Evaluation Board to any other party for any reason. Upon discontinuation of use of the Evaluation Board or termination of this Agreement, Customer agrees to promptly return the Evaluation Board to ADI. ADDITIONAL RESTRICTIONS. Customer may not disassemble, decompile or reverse engineer chips on the Evaluation Board. Customer shall inform ADI of any occurred damages or any modifications or alterations it makes to the Evaluation Board, including but not limited to soldering or any other activity that affects the material content of the Evaluation Board. Modifications to the Evaluation Board must comply with applicable law, including but not limited to the RoHS Directive. TERMINATION. ADI may terminate this Agreement at any time upon giving written notice to Customer. Customer agrees to return to ADI the Evaluation Board at that time. LIMITATION OF LIABILITY. THE EVALUATION BOARD PROVIDED HEREUNDER IS PROVIDED "AS IS" AND ADI MAKES NO WARRANTIES OR REPRESENTATIONS OF ANY KIND WITH RESPECT TO IT. ADI SPECIFICALLY DISCLAIMS ANY REPRESENTATIONS, ENDORSEMENTS, GUARANTEES, OR WARRANTIES, EXPRESS OR IMPLIED, RELATED TO THE EVALUATION BOARD INCLUDING, BUT NOT LIMITED TO, THE IMPLIED WARRANTY OF MERCHANTABILITY, TITLE, FITNESS FOR A PARTICULAR PURPOSE OR NON-INFRINGEMENT OF INTELLECTUAL PROPERTY RIGHTS. IN NO EVENT WILL ADI AND ITS LICENSORS BE LIABLE FOR ANY INCIDENTAL, SPECIAL, INDIRECT, OR CONSEQUENTIAL DAMAGES RESULTING FROM CUSTOMER'S POSSESSION OR USE OF THE EVALUATION BOARD, INCLUDING BUT NOT LIMITED TO LOST PROFITS, DELAY COSTS, LABOR COSTS OR LOSS OF GOODWILL. ADI'S TOTAL LIABILITY FROM ANY AND ALL CAUSES SHALL BE LIMITED TO THE AMOUNT OF ONE HUNDRED US DOLLARS (\$100.00). EXPORT. Customer agrees that it will not directly or indirectly export the Evaluation Board to another country, and that it will comply with all applicable United States federal laws and regulations relating to exports. GOVERNING LAW. This Agreement shall be governed by and construed in accordance with the substantive laws of the Commonwealth of Massachusetts (excluding conflict of law rules). Any legal action regarding this Agreement will be heard in the state or federal courts having jurisdiction in Suffolk County, Massachusetts, and Customer hereby submits to the personal jurisdiction and venue of such courts. The United Nations Convention on Contracts for the International Sale of Goods shall not apply to this Agreement and is expressly disclaimed.



Компания «ЭлектроПласт» предлагает заключение долгосрочных отношений при поставках импортных электронных компонентов на взаимовыгодных условиях!

Наши преимущества:

- Оперативные поставки широкого спектра электронных компонентов отечественного и импортного производства напрямую от производителей и с крупнейших мировых складов;
- Поставка более 17-ти миллионов наименований электронных компонентов;
- Поставка сложных, дефицитных, либо снятых с производства позиций;
- Оперативные сроки поставки под заказ (от 5 рабочих дней);
- Экспресс доставка в любую точку России;
- Техническая поддержка проекта, помощь в подборе аналогов, поставка прототипов;
- Система менеджмента качества сертифицирована по Международному стандарту ISO 9001;
- Лицензия ФСБ на осуществление работ с использованием сведений, составляющих государственную тайну;
- Поставка специализированных компонентов (Xilinx, Altera, Analog Devices, Intersil, Interpoint, Microsemi, Aeroflex, Peregrine, Syfer, Eurofarad, Texas Instrument, Miteq, Cobham, E2V, MA-COM, Hittite, Mini-Circuits, General Dynamics и др.);

Помимо этого, одним из направлений компании «ЭлектроПласт» является направление «Источники питания». Мы предлагаем Вам помощь Конструкторского отдела:

- Подбор оптимального решения, техническое обоснование при выборе компонента;
- Подбор аналогов;
- Консультации по применению компонента;
- Поставка образцов и прототипов;
- Техническая поддержка проекта;
- Защита от снятия компонента с производства.



Как с нами связаться

Телефон: 8 (812) 309 58 32 (многоканальный)

Факс: 8 (812) 320-02-42

Электронная почта: org@eplast1.ru

Адрес: 198099, г. Санкт-Петербург, ул. Калинина, дом 2, корпус 4, литера А.