

TPC-1782H

17" SXGA TFT LED LCD 4th. Gen. Intel® Core™ i3 Touch Panel Computer

NEW



Features

- Industrial 17" SXGA TFT LCD with 50K Lifetime LED Backlight
- Intel 4th Generation Core i3 1.7GHz with 4GB DDR3L SDRAM
- Compact Fanless Embedded System with AI Alloy Front Bezel
- IP65 Approved Front Protection & Panel Mounting
- More Durable 5-wire Resistive Touch Screen
- PCIe 1x and Mini PCIe Expansion Support
- Diverse system I/O and Isolated Digital I/O by iDoor Technology
- Supports Fieldbus Protocol by iDoor Technology
- 3G/GPS/GPRS/WiFi Communication by iDoor Technology
- Supports MRAM by iDoor Technology
- Chassis Grounding Protection
- Supports Advantech SNMP Subagent
- Supports Advantech SusiAccess Remote Device Management Software

Introduction

The TPC-1782H touch panel computer with a 17" SXGA LCD, low power embedded Intel 4th Generation Core i3 1.7GHz processor and 4GB DDR3L SDRAM provides the high computing performance in a compact fanless system. To enhance its durability, the TPC-1782H is designed with IP65 front protection, die-cast AI Alloy front bezel and 5-wire resistive touch. It also includes PCIe slot and Mini-pcie slots to extend the functionality and meet a variety of automation applications needs. Through the Mini-PCIe slot, Advantech iDoor technology can provide more I/O connectors, Isolated Digital I/O, the Fieldbus Protocol, 3G/GPS/GPRS/Wi-Fi Communication and MRAM. A 2nd monitor and speaker can be attached via the integrated HDMI and Audio port.

The pre-loaded SusiAccess is a smart, unique and ready-to-use remote device management software for you to centralize monitoring and managing of remote embedded devices in real-time. You can focus more on your own applications and let SusiAccess do the rest - configure systems, monitor device health, and recover from any system failures. It's cloud-based and provides on-demand software services so you can easily download and upgrade applications when you need.

Specifications

General

- BIOS**: AMI UEFI
- Certification**: BSMI, CCC, CE, FCC Class A, UL
- Cooling System**: Fanless design
- Dimensions (W x H x D)**: 414 x 347.5 x 84 mm (16.3" x 13.68" x 3.31")
Front bezel: Die-cast Aluminum alloy
Back housing: PC/ABS Resin
- Mounting**: Desktop, Wall or Panel Mount
- OS Support**: Microsoft® WES7 32bit/64bit Windows 7 32bit/64bit
Windows Embedded 8.1 Industry Pro 64bit
Windows 7 32bit/64bit
- Power Consumption**: 20W Typical, 60W Max. (Without Add-on card)
- Power Input**: 24V_{DC} ± 20%
- Watchdog Timer**: 1 ~ 255 sec (system)
- Weight (Net)**: 6 kg (13.23 lbs)

System Hardware

- CPU**: Intel 4th Generation Core i3-4010U 1.7GHz
- Chipset**: Lynx Point-LP
- Memory**: 4GB DDR3L 1600MHz SO-DIMM SDRAM
- LAN**: 10/100/1000 Base-T x 2 (one port supports iAMT)
- Expansion Slots**: Half-size PCIe 1x and Full-size Mini PCI-E
- Storage**: CFast slot x 1
2.5" SATA SSD slot x 1
- I/O**: RS-232 x 1, RS-232/422/485 x 1
USB 3.0 x 2, HDMI 1.4 x 1
Audio Line out x 1, USB 2.0 x 1 (optional)
Audio MIC x 1 (optional)

LCD Display

- Display Type**: SXGA TFT LED LCD
- Display Size**: 17"
- Max. Resolution**: 1280 x 1024

- Max. Colors**: 16.7 M
- Luminance cd/m²**: 350
- Viewing Angle (H/V°)**: 160/140
- Backlight Life**: 50,000 hrs
- Contrast Ratio**: 800:1

Touchscreen

- Lifespan**: 36 million touches at single point
- Light Transmission**: Above 75%
- Resolution**: Linearity
- Type**: 5-wire, analog resistive

Environment

- Humidity**: 10 ~ 95% RH @ 40°C, non-condensing
- Ingress Protection**: Front panel: IP65
- Operating Temperature**: 0 ~ 55°C (32 ~ 131°F)
- Storage Temperature**: -20 ~ 60°C (-4 ~ 140°F)
- Vibration Protection**: With HDD: 1 Grms (5 ~ 500 Hz)
(Operating, random vibration)

Rear View

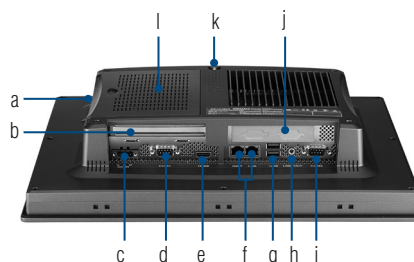

- a. CFast
- b. PCI-E Slot
- c. 24V_{DC} Power
- d. COM (RS-232)
- e. HDMI
- f. LAN
- g. USB3.0
- h. Audio Line Out
- i. COM (RS-232/422/485)
- j. iDoor
- k. SMA Connector for Antenna
- l. 2.5" SATA SSD Slot and Mini-PCIe Slot

Dimensions

Unit: mm

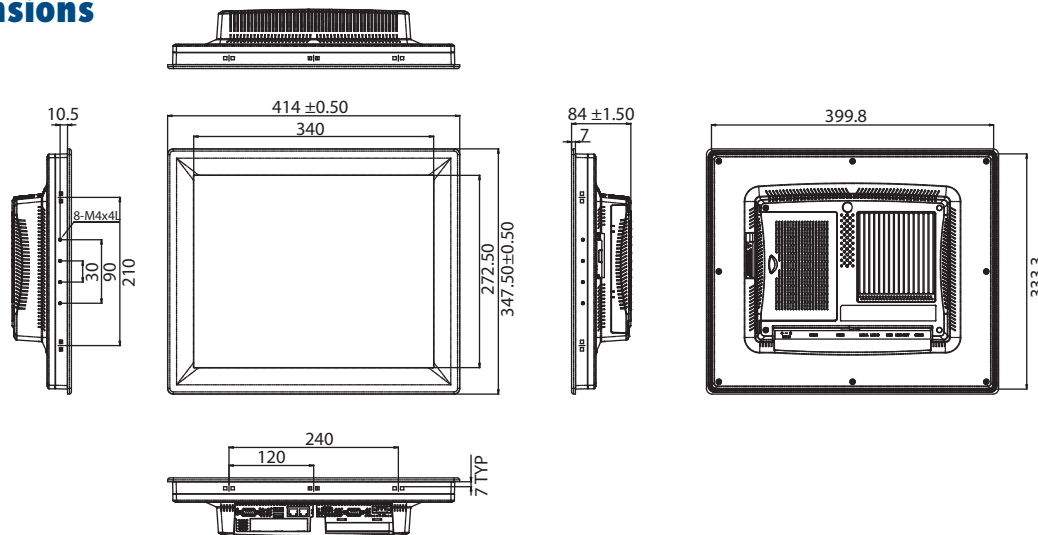

Panel Cut-out Dimensions: 400.8 x 334.3 mm (16.03" x 13.37")

Ordering Information

- TPC-1782H-433AE 17" SXGA Panel PC, Intel i3-4010U, 4GB, iDoor, PCIe
- TPC-1782H-473AE 17" SXGA Panel PC, Intel i7-4650U, 4GB, iDoor, PCIe

Accessories

- PWR-248-AE 150W DC 24V/6.25A Output Power Supply
- 1702002600 Power Cable US Plug 1.8 M
- 1702002605 Power Cable EU Plug 1.8 M
- 1702031801 Power Cable UK Plug 1.8 M
- 1700000596 Power Cable China/Australia Plug 1.8 M
- TPC-1000H-WMKE TPC VESA Mounting Kit from 10" to 17" TPC
- TPC-1000H-SMKE TPC Stand kit from 10" to 17" TPC
- EWM-W151H01E 802.11bgn RTL8188EE 1T1R, Half-size Mini-PCIe (also need 9656EWMG00E)
- 9656EWMG00E Half-size miniPCIe to Full-size miniPCIe bracket set
- 1750000318 EMI Antenna 2DBI 2.4GHz SMA CONN for ARK-3384
- 1750003222 802.11b/g 5dBi Dipole Antenna
- 1750003418 Wireless Antenna AN2400-5901RS R/P SMA.M9dB

Automation S/W & Embedded O/S

- 2070013102 TPC-xx82 WS7P x64 MUI Image v4.12 B005
- 968WEXP003X PanelExpress V2.0 300 tags S/W license
- 968WEXP015X PanelExpress V2.0 1500 tags S/W license
- 968WEXP050X PanelExpress V2.0 5000 tags S/W license
- 968WEXP2USB PanelExpress V2.0 S/W USB dongle

iDoor Modules

- PCM-24D2R4-AE 2-Port Isolated RS-422/485 mPCIe, DB9
- PCM-27D24DI-AE 24-Channel Isolated Digital I/O w/ counter mPCIe, DB37
- PCM-26D2CA-AE 2-Port Isolated CANBus mPCIe, CANOpen, DB9
- PCM-24R1TP-AE 1-Port Gigabit Ethernet, Intel® 82574L, mPCIe, RJ45
- PCM-24S2WF-AE WiFi 802.11 a/b/g/n 2T2R w/ Bluetooth4.0, Half-size mPCIe, 2-port SMA
- PCM-26D1DB-AE 1-Port Hilscher netX100 FieldBus mPCIe, PROFIBUS, DB9, Master
- PCM-26R2PN-AE 2-Port Hilscher netX100 FieldBus mPCIe, PROFINET, RJ45, Master
- PCM-26R2EC-AE 2-Port Hilscher netX100 FieldBus mPCIe, EtherCAT, RJ45, Master
- PCM-26R2EI-AE 2-Port Hilscher netX100 FieldBus mPCIe, EtherNet/IP, RJ45, Master
- PCM-26R2S3-AE 2-Port Hilscher netX100 FieldBus mPCIe, Sercos III, RJ45, Master

Application Software

SUSIAccess	Version: V2.1 or above An innovative remote device management software, allowing efficient remote monitoring, quick recovery & backup, and real-time remote configuration, to create a more intelligent and interconnected embedded computing solution.
WebAccess	Version: V7.1 or above WebAccess, as the core of Advantech's IoT solution, is full web browser-based software package for HMI and SCADA software. All HMI and SCADA software features including: Animated Graphics Displays, Real-time Data, Control, Trends, Alarms and Logs, are available in a standard web browser. WebAccess is built around the latest internet technologies. With its open architecture, vertical domain applications can easily be integrated.
PANEL EXPRESS <small>Designed For Convenience</small>	Version: V2.0.3.8 or above Panel Express, a windows based HMI mini SCADA, realizes the cross platform flexibility offered by WebOP Designer to switch hardware for the consideration of cost and performance become an easy job. Panel Express software provides the best economic and express solution for data intensive high-end HMI applications.
WebOP Designer	Version: V2.0.3.8 or above An easy to use integrated development tool featuring solution-oriented screen objects, high-end graphics, Windows fonts for multi-language applications. WebOP runtime, a part of WebOP Designer, guarantees reliability and performance because of the minimum system overhead, high communication data rates, and sub-second screen switching.
WebAccess/NMS	Visualizing device and platform network connectivity conditions and offering easier firmware and configuration solutions to ensure stable network connections.



Компания «ЭлектроПласт» предлагает заключение долгосрочных отношений при поставках импортных электронных компонентов на взаимовыгодных условиях!

Наши преимущества:

- Оперативные поставки широкого спектра электронных компонентов отечественного и импортного производства напрямую от производителей и с крупнейших мировых складов;
- Поставка более 17-ти миллионов наименований электронных компонентов;
- Поставка сложных, дефицитных, либо снятых с производства позиций;
- Оперативные сроки поставки под заказ (от 5 рабочих дней);
- Экспресс доставка в любую точку России;
- Техническая поддержка проекта, помощь в подборе аналогов, поставка прототипов;
- Система менеджмента качества сертифицирована по Международному стандарту ISO 9001;
- Лицензия ФСБ на осуществление работ с использованием сведений, составляющих государственную тайну;
- Поставка специализированных компонентов (Xilinx, Altera, Analog Devices, Intersil, Interpoint, Microsemi, Aeroflex, Peregrine, Syfer, Eurofarad, Texas Instrument, Miteq, Cobham, E2V, MA-COM, Hittite, Mini-Circuits, General Dynamics и др.);

Помимо этого, одним из направлений компании «ЭлектроПласт» является направление «Источники питания». Мы предлагаем Вам помощь Конструкторского отдела:

- Подбор оптимального решения, техническое обоснование при выборе компонента;
- Подбор аналогов;
- Консультации по применению компонента;
- Поставка образцов и прототипов;
- Техническая поддержка проекта;
- Защита от снятия компонента с производства.



Как с нами связаться

Телефон: 8 (812) 309 58 32 (многоканальный)

Факс: 8 (812) 320-02-42

Электронная почта: org@eplast1.ru

Адрес: 198099, г. Санкт-Петербург, ул. Калинина, дом 2, корпус 4, литера А.