



# DIN Signal female connector



## General information

Design	IEC 60603-2, types: B, 2B, 3B, C, 2C, 3C			
No. of contacts	max. 96			
Contact spacing	2,54 mm			
Test voltage	1000V			
Contact resistance	max. 20mOhm			
Insulation resistance	min. 10 <sup>10</sup> Ohm			
Working current	2A at 20°C (see derating diagram)			
Temperature range	-55°C ... +125°C -40°C ... +105°C (for press-in connectors)			
Termination technology	press-in, solder pins, solder lugs, wirewrap			
Clearance & creepage distance	min. 1,2 mm each			
Insertion and withdrawal force	16-pole max. 15N	20-pole max. 20N	30-pole max. 30N	32-pole max. 30N
	48-pole max. 45N	64-pole max. 60N	96-pole max. 90N	
Mating cycles	PL 1 acc. to IEC 60603-2	500 mating cycles		
	PL 2 acc. to IEC 60603-2	400 mating cycles		
	PL 3 acc. to IEC 60603-2	50 mating cycles		
UL file	E102079			
RoHS - compliant	Yes			
Leadfree	Yes			
Hot plugging	No			

## Insulator material

Material	PBT (thermoplastics, glass fiber reinforcement 30%)
Color	RAL 7032 (grey)
UL classification	UL 94-V0
Material group acc. IEC 60664-1	111a (175 < CTI < 400)
NFF classification	I3, F4

## Contact material

Contact material	Copper alloy
Plating termination zone	Sn over Ni for solder, Ni for press-in & wirewrap
Plating contact zone I	Au over Ni
Plating contact zone II (termination side)	Au over Ni

## Derating diagram acc. to IEC 60512-5 (Current carrying capacity)

The current carrying capacity is limited by maximum temperature of materials for inserts and contacts including terminals.

The current capacity curve is valid for continuous, non interrupted current loaded contacts of connectors when simultaneous power on all contacts is given, without exceeding the maximum temperature.

Control and test procedures according to DIN IEC 60512-5

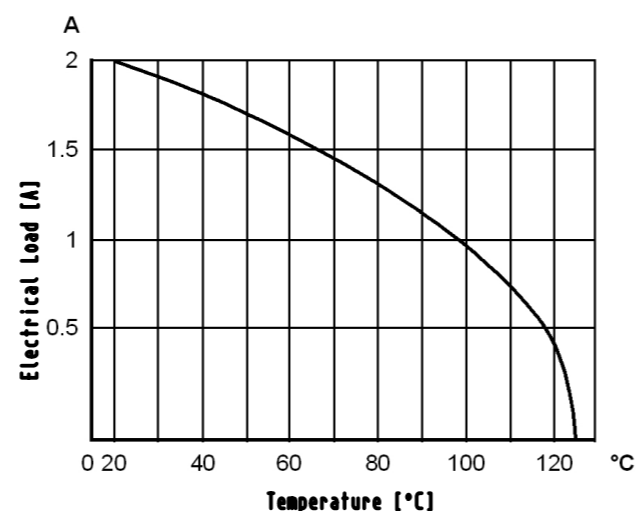

## Recommended configuration of plated through holes for press-in termination

In addition to the hot-air-level (HAL), other PCB surfaces are getting more important. Due to their different properties - such as mechanical strength and coefficient of friction - we recommend the following configuration of PCB through holes.

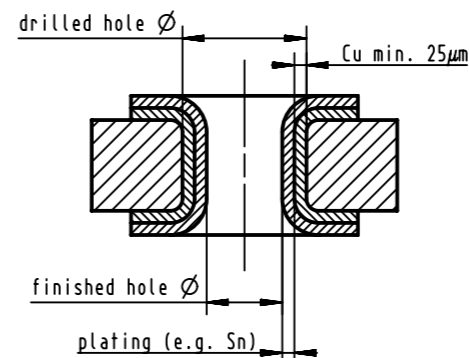

Plating	Drilled hole Ø	Plated hole Ø
Tin plated PCB (HAL) acc. to EN 60352-5	1,15±0,025 mm	0,94 - 1,09 mm
	Sn	max. 15 µm
Chemical tin plated PCB	1,15±0,025 mm	1,00 - 1,10 mm
	Sn	min. 0,8 µm
Gold /Nickel plated PCB	1,15±0,025 mm	1,00 - 1,10 mm
	Ni	3 - 7 µm
	Au	0,05 - 0,12 µm
Silver plated PCB	1,15±0,025 mm	1,00 - 1,10 mm
	Ag	0,1 - 0,3 µm
Copper plated PCB (OSP)	1,15±0,025 mm	1,00 - 1,10 mm

## Assembly instructions

It is highly recommended to use HARTING press-in tools to ensure a reliable press-in process. Please refer to the catalogue for tools, machines and further information about the press-in process.

## Soldering instructions

The connectors should be protected when being soldered in a dip, flow or film soldering baths. Otherwise, they might become contaminated as a result of soldering operations or deformed as a result of overheating.

(1) For prototypes and short runs protect the connectors with an industrial adhesive tape, e.g. Tesaband 4331 (www.tesa.de). Cover the underside of the connector moulding and the adjacent parts of the pcb as well as the open sides of the connector. This will prevent heat and gases of the soldering apparatus from damaging the connector. About 140 + 5 mm of the tape should suffice.

(2) For large series a jig is recommended. Its protective cover with a fast action mechanical locking device shields the connectors from gas and heat generated by the soldering apparatus. As an additional protection a foil can be used for covering the parts that should not be soldered.

## Cross section of solder terminations

## Cross section of solder terminations

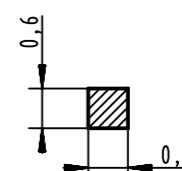
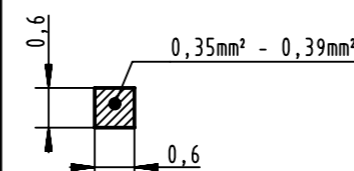

All Dimensions in mm Original Size DIN A3		Scale 1:1	Free size tol.	Ref. Sub. Rev. A / 22.01.2013	
All rights reserved Department EC PD - DE		Created by TADJE	Inspected by LEHNERT	Standardisation HOFFMANN	Date 2013-01-29
HARTING Electronics GmbH D-32339 Espelkamp		Title DIN Signal female connector			State Final Release
		Type DS	Number 09032100002	Doc-Key / ECM-Nr. 100523061/UGD/001/B 50000058740	Rev. B
					Page 1/1

# Mouser Electronics

Authorized Distributor

Click to View Pricing, Inventory, Delivery & Lifecycle Information:

[HARTING:](#)

[09037966823](#) [09022646870](#) [09037646821](#) [09037646823](#)



Компания «ЭлектроПласт» предлагает заключение долгосрочных отношений при поставках импортных электронных компонентов на взаимовыгодных условиях!

Наши преимущества:

- Оперативные поставки широкого спектра электронных компонентов отечественного и импортного производства напрямую от производителей и с крупнейших мировых складов;
- Поставка более 17-ти миллионов наименований электронных компонентов;
- Поставка сложных, дефицитных, либо снятых с производства позиций;
- Оперативные сроки поставки под заказ (от 5 рабочих дней);
- Экспресс доставка в любую точку России;
- Техническая поддержка проекта, помощь в подборе аналогов, поставка прототипов;
- Система менеджмента качества сертифицирована по Международному стандарту ISO 9001;
- Лицензия ФСБ на осуществление работ с использованием сведений, составляющих государственную тайну;
- Поставка специализированных компонентов (Xilinx, Altera, Analog Devices, Intersil, Interpoint, Microsemi, Aeroflex, Peregrine, Syfer, Eurofarad, Texas Instrument, Miteq, Cobham, E2V, MA-COM, Hittite, Mini-Circuits, General Dynamics и др.);

Помимо этого, одним из направлений компании «ЭлектроПласт» является направление «Источники питания». Мы предлагаем Вам помощь Конструкторского отдела:

- Подбор оптимального решения, техническое обоснование при выборе компонента;
- Подбор аналогов;
- Консультации по применению компонента;
- Поставка образцов и прототипов;
- Техническая поддержка проекта;
- Защита от снятия компонента с производства.



#### Как с нами связаться

**Телефон:** 8 (812) 309 58 32 (многоканальный)

**Факс:** 8 (812) 320-02-42

**Электронная почта:** [org@eplast1.ru](mailto:org@eplast1.ru)

**Адрес:** 198099, г. Санкт-Петербург, ул. Калинина, дом 2, корпус 4, литера А.