

2.5V/3.3V, High Bandwidth, Hot Insertion 10-Bit, 2-Port, Bus Switch

Features

- Near-Zero propagation delay
- 5-ohm switches connect inputs to outputs
- High Bandwidth (>400 MHz)
- Permits Hot Insertion.
- Rail-to-Rail, 3.3V or 2.5V Switching
- 5V I/O Tolerant
- 2.5V Supply Voltage Operation
- Packaging (Pb-free & Green):
 - 24-pin 150-mil wide plastic QSOP (Q)

Description

Pericom Semiconductor's PI3C3384 is a 2.5V or 3.3V, high bandwidth 10-bit, 2-port bus switches designed with a low On-Resistance allowing inputs to be connected directly to outputs. The bus switch creates no additional propagational delay or additional ground bounce noise. The switches are turned ON by the Bus Enable (BE) input signal. Two bus enable signals are provided, one for each of the upper and lower five bits of the two 10-bit buses.

Applications

- High Bandwidth Data switching
- Hot Docking

Block Diagram

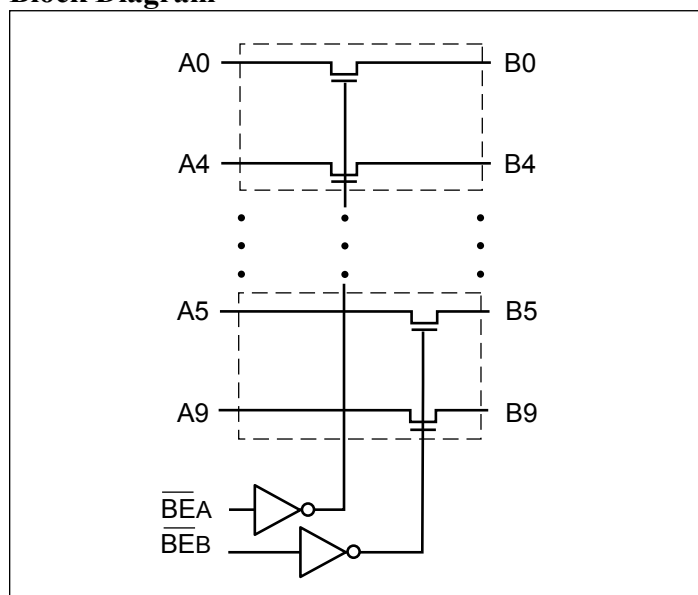

Pin Configuration

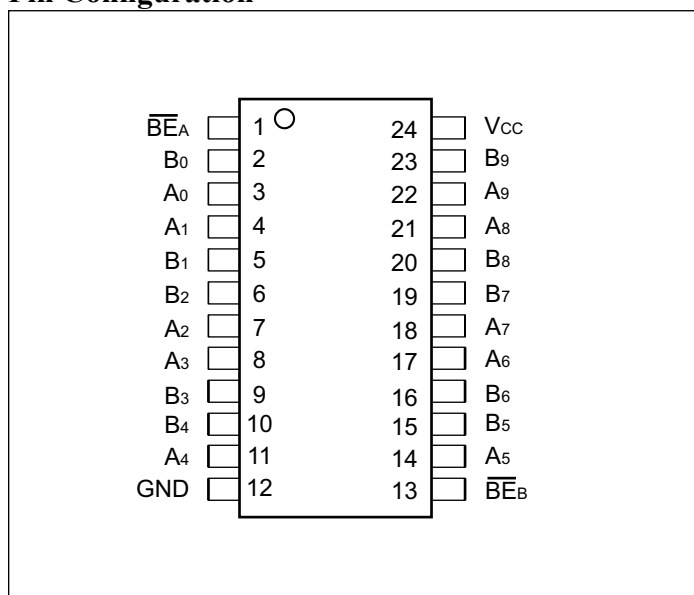

Truth Table⁽¹⁾

Function	\overline{BE}_A	\overline{BE}_B	B0-B4	B5-B9
Disconnect	H	H	Hi-Z	Hi-Z
Connect	L	H	A0-A4	Hi-Z
Connect	H	L	Hi-Z	A5-A9
Connect	L	L	A0-A4	A5-A9

Note:

1. High Voltage Level, X = Don't Care,
L = Low Voltage Level, Hi-Z = High Impedance

Pin Description

Pin Name	Description
$\overline{BE}_A, \overline{BE}_B$	Bus Enable Inputs (Active LOW)
A0 - A9	Bus A
B0 - B9	Bus B
GND	Ground
VCC	Power

Maximum Ratings

(Above which the useful life may be impaired. For user guidelines, not tested.)

Storage Temperature	-65°C to +150°C
Ambient Temperature with Power Applied	-40°C to +85°C
Supply Voltage to Ground Potential (Input & V _{CC} Only)	-0.5V to +4.6V
Supply Voltage to Ground Potential (Outputs & D/O Only)	-0.5V to +4.6V
DC Input Voltage	-0.5V to +5.5V
DC Output Current.....	120mA
Power Dissipation.....	1.0W

Note:

Stresses greater than those listed under MAXIMUM RATINGS may cause permanent damage to the device. This is a stress rating only and functional operation of the device at these or any other conditions above those indicated in the operational sections of this specification is not implied. Exposure to absolute maximum rating conditions for extended periods may affect reliability.

DC Electrical Characteristics (Over Operating Range, T_A = -40°C to +85°C, V_{CC} = 3.3V ± 10%)

Parameters	Description	Test Conditions ⁽¹⁾	Min	Typ. ⁽²⁾	Max	Units
V _{IH}	Input HIGH Voltage	Guaranteed Logic HIGH Level	2.0			V
V _{IL}	Input LOW Voltage	Guaranteed Logic Low Level	-0.5		0.8	
I _{IH}	Input HIGH Current	V _{CC} = Max, V _{IN} = V _{CC}			±1	µA
I _{IL}	Input LOW Current	V _{CC} = Max, V _{IN} = GND			±1	
I _{OZH}	High-Impedance Output Current	0 ≤ A, B ≤ V _{CC}			±1	
V _{IK}	Clamp Diode Voltage	V _{CC} = Min, I _{IN} = -18mA		-0.73	-1.2	V
R _{ON}	Switch On Resistance ⁽³⁾	V _{CC} = Min, V _{IN} = 0.0V I _{ON} = 48mA or 64mA		5	7	Ω
		V _{CC} = Min, V _{IN} = 0.0V I _{ON} = 48mA or 64mA		8	15	

Capacitance (T_A = 25°C, f = 1 MHz)

Parameters ⁽⁴⁾	Description	Test Conditions	Typ.	Units
C _{IN}	Input Capacitance	V _{IN} = 0V	3.5	pF
COFF	A/B Capacitance, Switch Off		5.0	
CON	A/B Capacitance, Switch On		10.0	

Notes:

1. For Max. or Min. conditions, use appropriate value specified under Electrical Characteristics for the applicable device type.
2. Typical values are at V_{CC} = 3.3V, T_A = 25°C ambient and maximum loading.
3. Measured by the voltage drop between A and B pin at indicated current through the switch. ON resistance is determined by the lower of the voltages on the two (A,B) pins.
4. This parameter is determined by device characterization but is not production tested.

Power Supply Characteristics

Parameters	Description	Test Conditions ⁽¹⁾	Min.	Typ. ⁽²⁾	Max.	Units
ICC	Quiescent Power Supply Current	V _{CC} = Max, V _{IN} = GND or V _{CC}		260	500	μA
DICC	Supply Current per Input @ TTL HIGH	V _{CC} = Max, V _{IN} = 3.0V ⁽³⁾			750	

Notes:

1. For Max. or Min. conditions, use appropriate value specified under Electrical Characteristics for the applicable device.
2. Typical values are at V_{CC} = 3.3V, +25°C ambient.
3. Per TTL driven input (control inputs only); A and B pins do not contribute to ICC.

Switching Characteristics over 3.3V Operating Range

Parameters	Description	Conditions ⁽¹⁾	Com.		Units
			Min	Max	
tPLH tPHL	Propogation Delay ^(2,3) Ax to Bx, Bx to Ax	C _L = 50pF R _L = 500-ohm		0.25	ns
tPZH tPZL	Bus Enable Time $\overline{\text{BEx}}$ to Ax or Bx	C _L = 50pF R _L = 500-ohm	1.5	6.5	
tPHZ tPLZ	Bus Disable Time $\overline{\text{BEx}}$ to Ax or Bx	R = 500-ohm	1.5	5.5	

Switching Characteristics over 2.5V Operating Range

Parameters	Description	Conditions ⁽¹⁾	Com.		Units
			Min	Max	
tPLH tPHL	Propogation Delay ^(2,3) Ax to Bx, Bx to Ax	C _L = 50pF R _L = 500-ohm		0.25	ns
tPZH tPZL	Bus Enable Time $\overline{\text{BEx}}$ to Ax or Bx	C _L = 50pF R _L = 500-ohm	1.5	9.8	
tPHZ tPLZ	Bus Disable Time $\overline{\text{BEx}}$ to Ax or Bx	R = 500-ohm	1.5	8.3	

Notes:

1. See test circuit and waveforms.
2. This parameter is guaranteed but not tested on Propagation Delays.
3. The bus switch contributes no propagational delay other than the RC delay of the ON resistance of the switch and the load capacitance. The time constant for the switch alone is of the order of 0.25ns for 50pF load. Since this time constant is much smaller than the rise/fall times of typical driving signals, it adds very little propagational delay to the system. Propagational delay of the bus switch when used in a system is determined by the driving circuit on the driving side of the switch and its interaction with the load on the driven side.

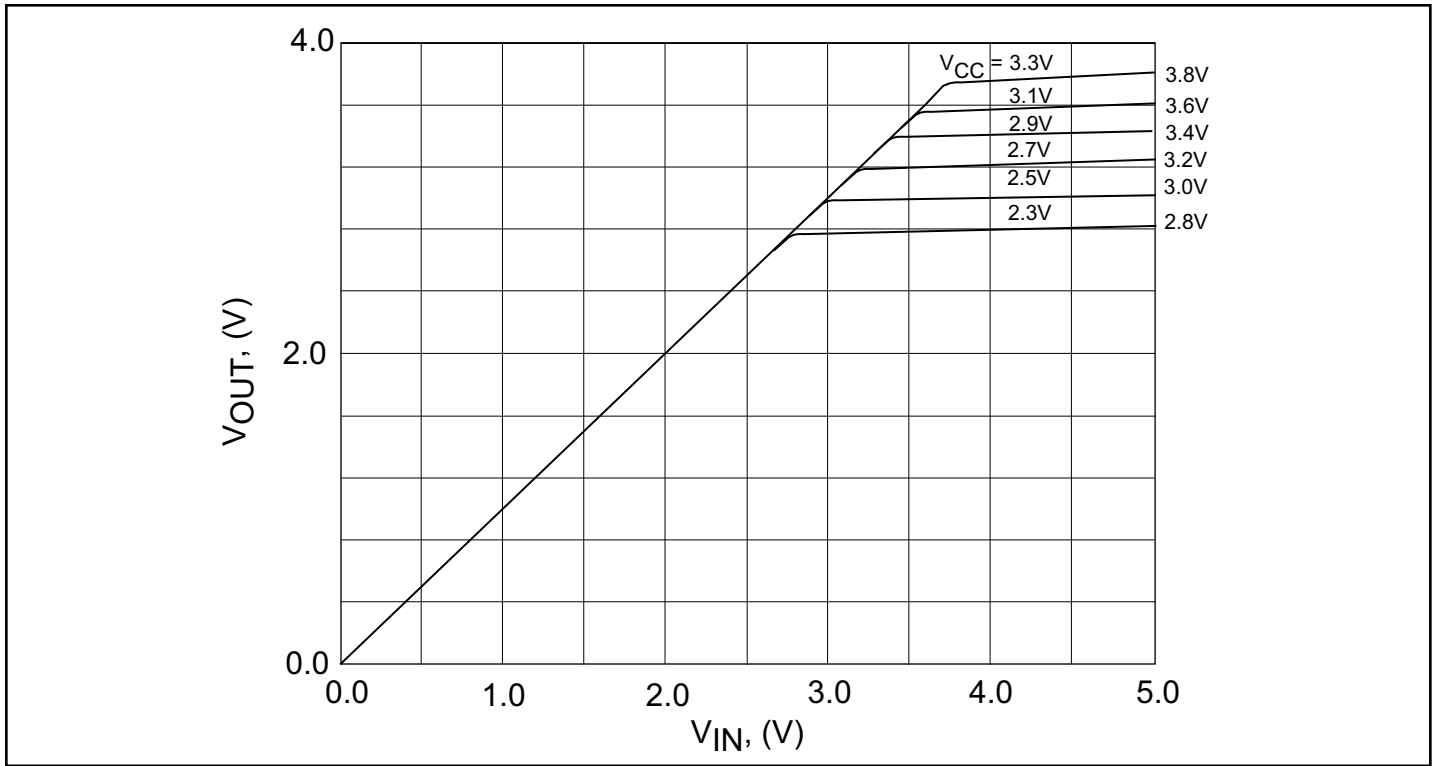

Output Voltage vs. Input Voltage over Various Supply Voltages

Test Circuit

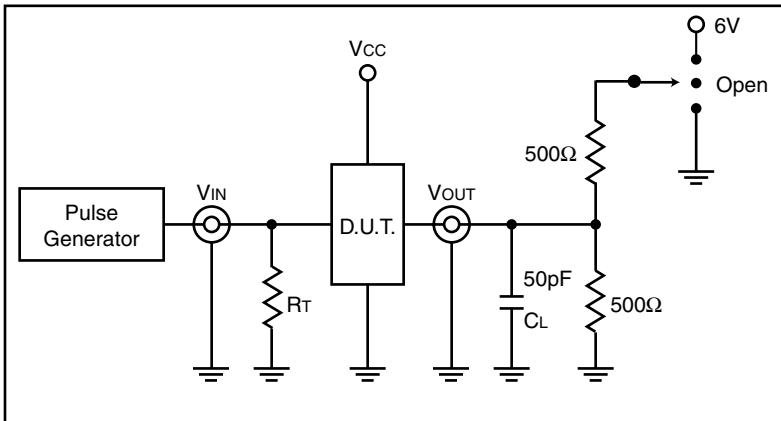

Switch Position

Test	Switch
Disable LOW	6V
Enable LOW	6V
Disable HIGH	GND
Enable HIGH	GND
t _{PD}	Open

Definitions:

C_L = Load capacitance (includes jig and probe capacitance)
R_T = Termination resistance (should be equal to Z_{OUT} of the pulse generator)

Enable and Disable Timing

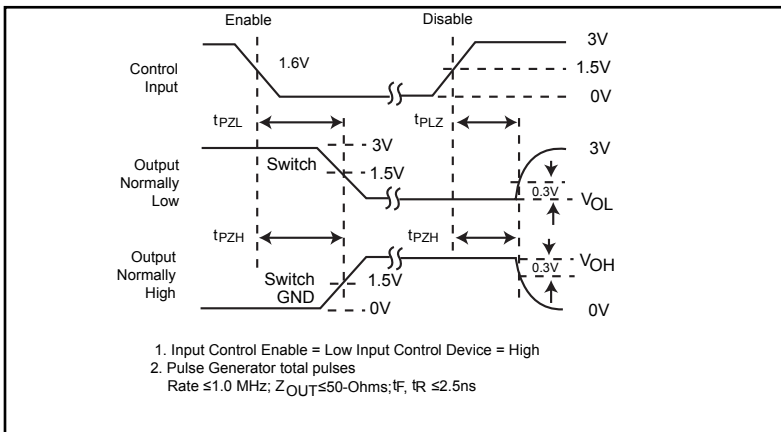

Propagation Delay

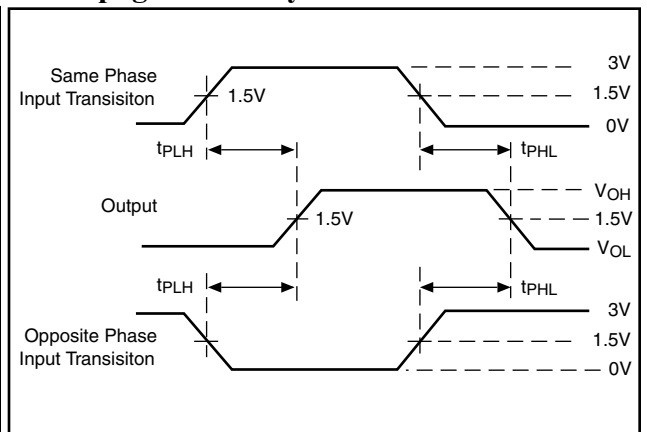

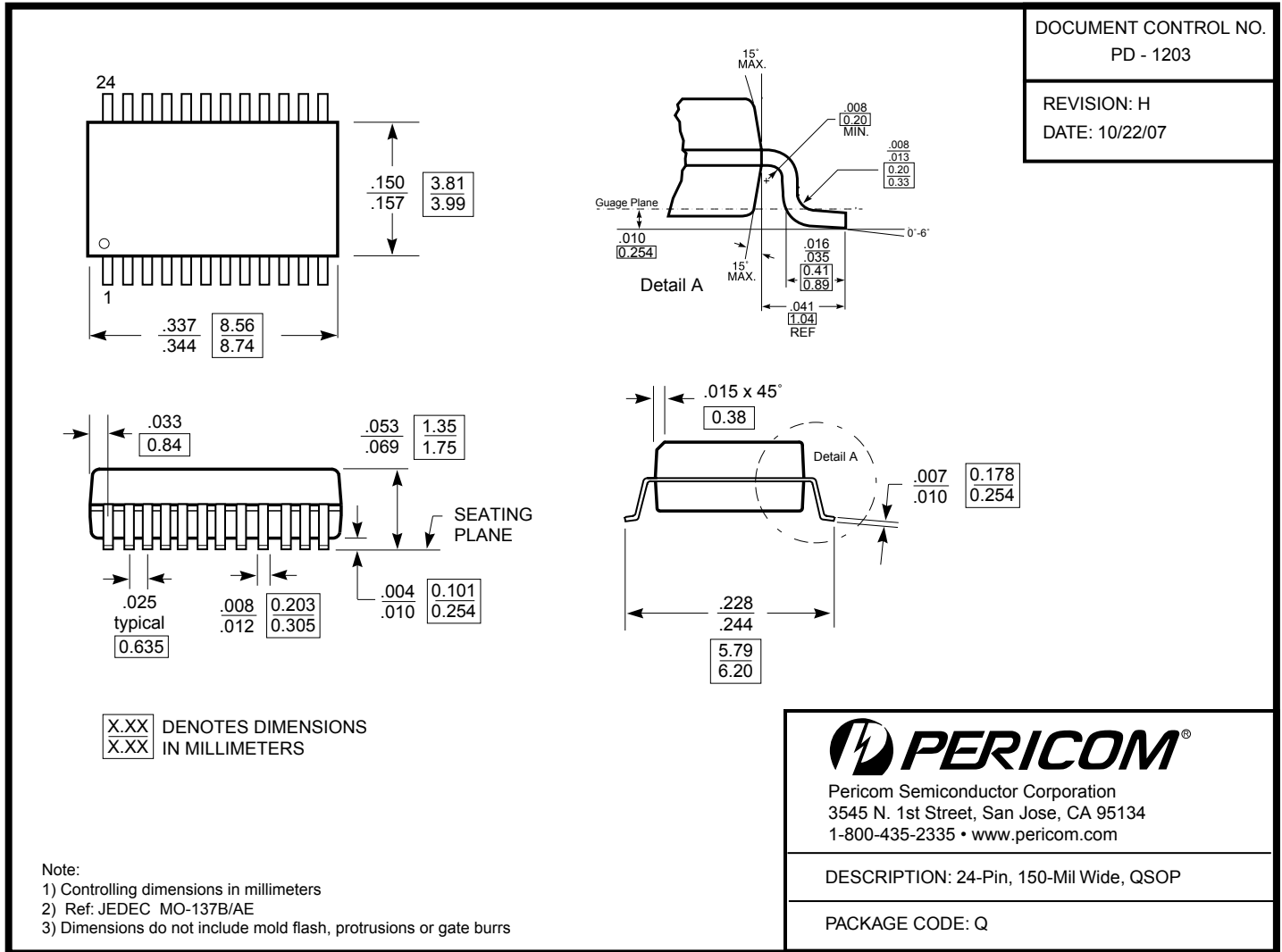

Ordering Information

Ordering Code	Package Code	Package Description
PI3C3384QE	Q	Pb-Free & Green, 24-pin QSOP

Notes:

- Thermal characteristics can be found on the company web site at www.pericom.com/packaging/
- E = Pb-free and Green
- Adding an X suffix = Tape/Reel

Mouser Electronics

Authorized Distributor

Click to View Pricing, Inventory, Delivery & Lifecycle Information:

[Diodes Incorporated:](#)

[PI3C3384QE](#)



Компания «ЭлектроПласт» предлагает заключение долгосрочных отношений при поставках импортных электронных компонентов на взаимовыгодных условиях!

Наши преимущества:

- Оперативные поставки широкого спектра электронных компонентов отечественного и импортного производства напрямую от производителей и с крупнейших мировых складов;
- Поставка более 17-ти миллионов наименований электронных компонентов;
- Поставка сложных, дефицитных, либо снятых с производства позиций;
- Оперативные сроки поставки под заказ (от 5 рабочих дней);
- Экспресс доставка в любую точку России;
- Техническая поддержка проекта, помощь в подборе аналогов, поставка прототипов;
- Система менеджмента качества сертифицирована по Международному стандарту ISO 9001;
- Лицензия ФСБ на осуществление работ с использованием сведений, составляющих государственную тайну;
- Поставка специализированных компонентов (Xilinx, Altera, Analog Devices, Intersil, Interpoint, Microsemi, Aeroflex, Peregrine, Syfer, Eurofarad, Texas Instrument, Miteq, Cobham, E2V, MA-COM, Hittite, Mini-Circuits, General Dynamics и др.);

Помимо этого, одним из направлений компании «ЭлектроПласт» является направление «Источники питания». Мы предлагаем Вам помощь Конструкторского отдела:

- Подбор оптимального решения, техническое обоснование при выборе компонента;
- Подбор аналогов;
- Консультации по применению компонента;
- Поставка образцов и прототипов;
- Техническая поддержка проекта;
- Защита от снятия компонента с производства.



Как с нами связаться

Телефон: 8 (812) 309 58 32 (многоканальный)

Факс: 8 (812) 320-02-42

Электронная почта: org@eplast1.ru

Адрес: 198099, г. Санкт-Петербург, ул. Калинина, дом 2, корпус 4, литера А.