

SL1010A Series



**Description**

The SL1010A Series Gas Discharge Tube (GDT) offers a compact, three-terminal, surface mount component that's just 5mm in diameter. It is rated for 10 hits ( $\pm 5$  repetitions) of a 5kA 8/20 $\mu$ s surge event with a low off-state capacitance of 1.5pF. Its low arc voltage parameter of 10V reduces thermal accumulation during long-term power fault events.

**Agency Approvals**

| AGENCY | AGENCY FILE NUMBER |
|--------|--------------------|
|        | E128662            |

**3 Electrode GDT Graphical Symbol**



**Additional Information**



Datasheet



Resources



Samples

**Features**

- 5mm diameter size
- Low insertion loss
- Fast response time
- Single component balanced protector (T-grd & R-grd)
- High current rating
- Stable performance over lifetime
- Lead-free and RoHS compliant
- UL Recognized

**Applications**

- Data lines
- Broadband interfaces such as ADSL2/VDSL2
- xDSL equipment
- Satellite and CATV equipment
- General telecom equipment
- Industrial automation
- Home gateway

### Electrical Characteristics

| Part Number | Device Specifications (at 25°C)                  |     |     |  |   |                       |                             |  | Nominal Impulse Discharge Current (x10@8/20µs) | Nominal Impulse Discharge Current (x1@10/350µs) |
|-------------|--|-----|-----|--|---|-----------------------|-----------------------------|--|--|---|
|             | DC Breakdown in Volts <sup>1,2,3</sup> (@100V/s) |     |     | Impulse Breakdown in Volts <sup>2,3</sup> (@100V/µs) | Impulse Breakdown In Volts <sup>2,3</sup> (@1kV/µs) | Insulation Resistance | Capacitance (@1MHz 0V Bias) | Arc Voltage (on state Voltage) @1Amp Min |  |   |
|             | MIN  | TYP | MAX | MAX  |   | MIN                   | MAX                         |  |  |   |
| SL1010A075  | 60   | 75  | 90  | 450  | 600   | >1GΩ (at 50VDC)       | <1.5 pF                     | ~10 V                                    | 5kA  | 1kA   |
| SL1010A090  | 72   | 90  | 108 | 550  | 700   |                       |                             |  |  |   |
| SL1010A170  | 136  | 170 | 204 | 580  | 750   |                       |                             |  |  |   |
| SL1010A230  | 184  | 230 | 276 | 850  | 1000  |                       |                             |  |  |   |
| SL1010A350  | 280  | 350 | 420 | 800  | 950   |                       |                             |  |  |   |
| SL1010A470  | 376  | 470 | 564 |  |   |                       |                             |  |  |   |

Notes:

- At delivery AQL 0.65 level II, DIN ISO 2859
- In ionized mode, tested according to ITU-T Rec. K.12
- Comparable to the silicon measurement Switching Voltage (Vs)
- Total current through center electrode at 10kA, through side electrode respectively at 5kA

### Product Characteristics

|                        |  |  |                     |
|------------------------|--|--|---------------------|
| <b>Materials</b>       | <b>Construction:</b> Ceramic Insulator                         | <b>Glow to Arc Transition Current</b>      | ~1 Amp              |
|                        | <b>Device Finish:</b> Dull Tin-plated<br>17.5 +/- 12.5 microns |  | <b>Glow Voltage</b> |
| <b>Product Marking</b> | Littelfuse 'LF' Mark, voltage and date code                    | <b>Storage and Operational Temperature</b> | -40 to +90°C        |

### Device Dimensions

For SL1010A series:

Dimensions are in millimeters [and inches]

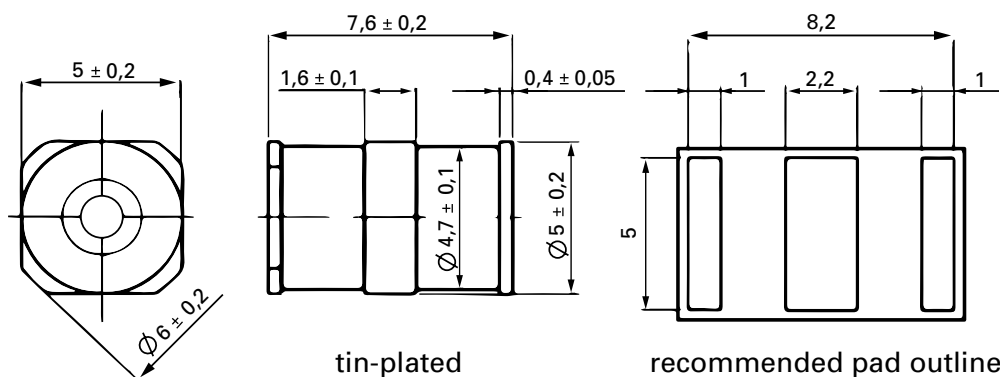

For SL1010A series failsafe version:

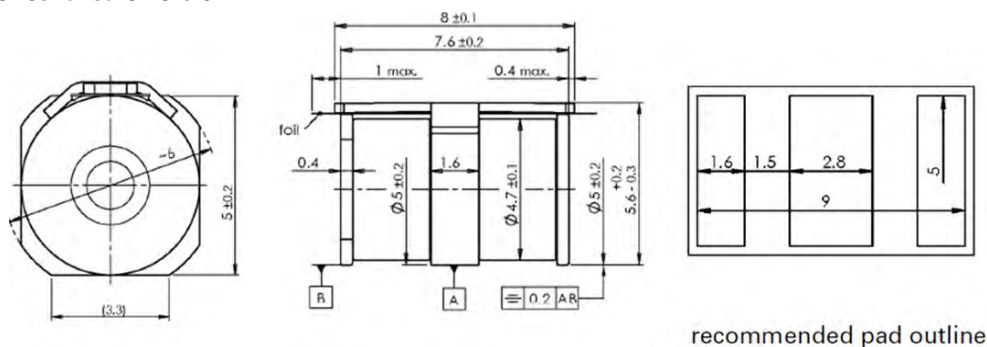

**Soldering Parameters - Reflow Soldering (Surface Mount Devices)**

|   |                                    |                         |
|---|------------------------------------|-------------------------|
| Reflow Condition                                      |                                    | Pb-free assembly        |
| Pre Heat  | - Temperature Min ( $T_{s(min)}$ ) | 150°C                   |
|   | - Temperature Max ( $T_{s(max)}$ ) | 200°C                   |
|   | - Time (Min to Max) ( $t_s$ )      | 60 – 180 seconds        |
| Average Ramp-up Rate (LiquidusTemp ( $T_L$ ) to peak) |                                    | 3°C/second max.         |
| $T_{s(max)}$ to $T_L$ - Ramp-up Rate                  |                                    | 5°C/second max.         |
| Reflow  | - Temperature ( $T_L$ ) (Liquidus) | 217°C                   |
|   | - Temperature ( $t_L$ )            | 60 – 150 seconds        |
| Peak Temperature ( $T_p$ )                            |                                    | 260 <sup>+0/-5</sup> °C |
| Time within 5°C of Actual Peak Temperature ( $t_p$ )  |                                    | 10 – 30 seconds         |
| Ramp-down Rate  |                                    | 6°C/second max.         |
| Time 25°C to Peak Temperature ( $T_p$ )               |                                    | 8 minutes max.          |
| Do not exceed   |                                    | 260°C                   |

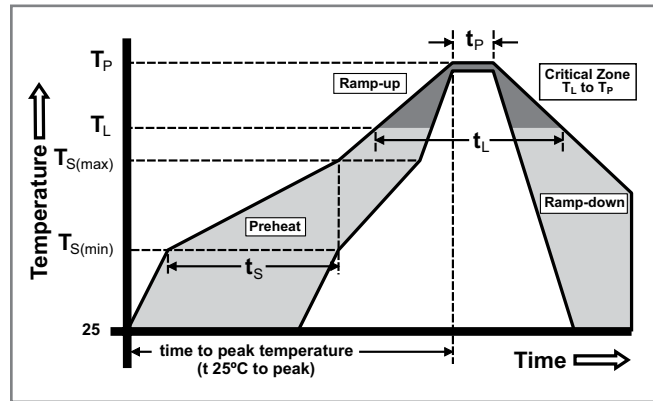

**Soldering Parameters - Hand Soldering**

Solder Iron Temperature: 350° C +/- 5°C  
Heating Time: 5 seconds max.

**Packaging**

**'SM' Type Surface Mount Items:** Packaged tape and reel carrier, 900 pcs/reel (specifications below)

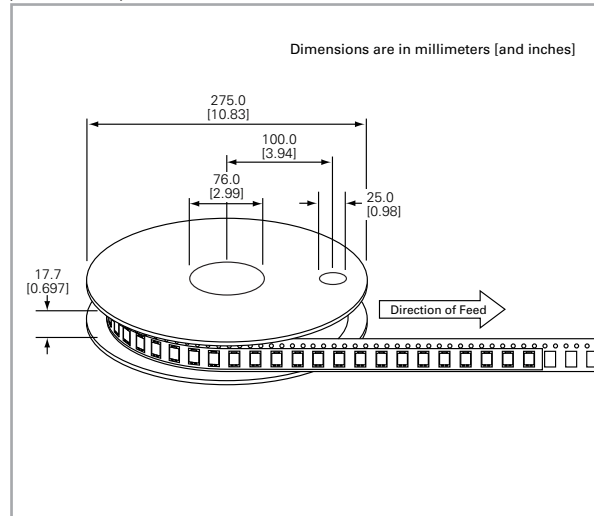
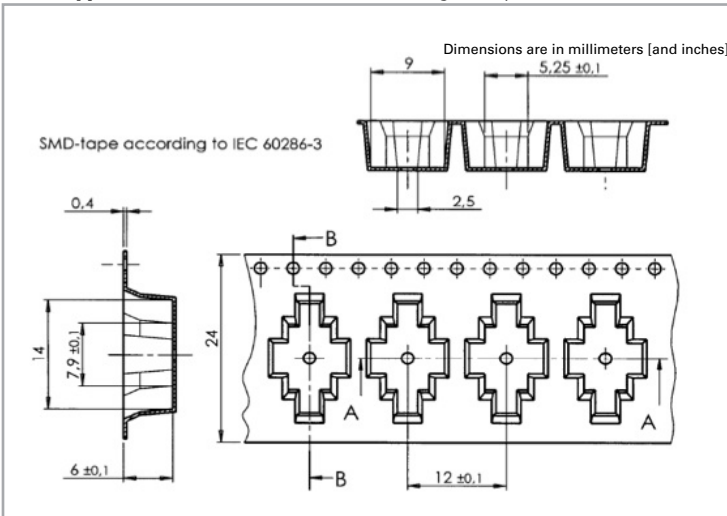

**Part Numbering System and Ordering Information**

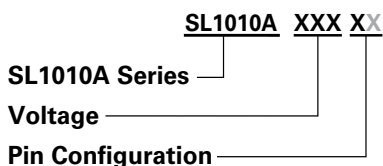

- F** = with Failsafe (Packed in carrier and tape, 900pcs/reel)
- SM** = Surface Mount (Packed in carrier and tape, 900pcs/reel)
- SMF** = Surface Mount with Failsafe (Packed in carrier and tape, 900pcs)

## SL1122A Series Hybrid



### Description

The SL1122A series Hybrid features a high performance Alpha Gas Plasma Tube in conjunction with a MOV. These devices are matched so that high speed pulses are initially clamped by the MOV, then as the current rises, the transient energy is switched through the gas tube. The Hybrid offers high levels of performance on fast rising transients in the domain of 100V/μs to 10 kV/μs, so eliminates the dv/dt switching delay normally exhibited by standard GDTs. These devices are extremely robust and are able to divert a 10,000 Amp pulse without destruction.

### Agency Approvals

| AGENCY  | AGENCY FILE NUMBER |
|---|--------------------|
|  | E128662            |

### 2 Electrode GDT Graphical Symbol

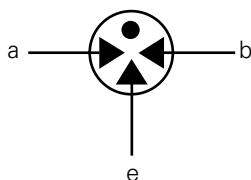

a = TIP  
b = RING  
e = GROUND  
(centre electrode)

### Features

- RoHs Compliant
- Excellent response to fast rising transients
- Flat response up to 10kV/μs
- 10kA surge capability tested with 8/20μs pulse as defined by IEC 61000-4-5
- Thermal failsafe

### Applications

- MDF protection
- ADSL equipment
- XDSL equipment
- Alarm panels
- General telecom equipment

### Additional Information



Datasheet



Resources



Samples

### Electrical Characteristics

| Part Number | Device Specifications (at 25°C)                |     |     |  |                               |  | Life Ratings                             |  |  |  |                                  |
|-------------|--|-----|-----|--|-------------------------------|--|--|--|--|--|----------------------------------|
|             | DC Breakdown in Volts <sup>1,2</sup> (@100V/s) |     |     | DC Voltage <sup>2</sup> (1kV/μs Ignition Time) | Insulation Resistance         | Capacitance (@1MHz, 0V bias, 1V oscillation) | Arc Voltage (on state voltage) @1Amp Min | Surge Life <sup>1</sup> (10/1000μs 300x +/-) | Surge Current <sup>1</sup> (8/20μs x 10) | Nominal AC Discharge Current <sup>1</sup> (10x1s@50Hz) | DC Holdover Voltage (<150msecs.) |
|             | MIN  | TYP | MAX |  | MIN                           | MAX  | TYP                                      |  |  | TYP  |                                  |
| SL1122A090  | 72   | 90  | 108 | 200 (< 10μs)                                   | > 10 <sup>8</sup> Ω (at 50V)  | 270 pF                                       | ~10 to 35 Volts                          | 200 A  | 10 kA                                    | 10 A   | 50 V                             |
| SL1122A230  | 184  | 230 | 276 | 350 (< 10μs)                                   | > 10 <sup>8</sup> Ω (at 100V) | 100 pF                                       |  |  |  |  | 135 V                            |
| SL1122A260  | 210  | 260 | 310 | 400 (< 10μs)                                   |                               |  |  |  |  |  |                                  |

Tested in accordance with ITU-T Rec K.12

Notes:

1. Total current through centre electrode
2. Maximum Peak Break Over Voltage

**Product Characteristics**

|                        |   |
|------------------------|---|
| <b>Materials</b>       | <b>Electrode Base:</b> Copper<br><b>Electrode Plating:</b> Bright Tin<br><b>Body:</b> Ceramic |
| <b>Product Marking</b> | Littelfuse 'LF' Mark, voltage and date code. Red.   |

|  |   |
|--|---|
| <b>Glow to Arc Transition Current</b>      | ~1 Amp                                    |
| <b>Glow Voltage</b>                        | ~60 to 200 Volts                          |
| <b>Storage and Operational Temperature</b> | -40 to +90°C                              |
| <b>Transverse Voltage (Delay Time)</b>     | < 0.2 μSec.<br>(Tested to ITU-T Rec.K.12) |

**Device Dimensions**

**Radial Lead Devices**

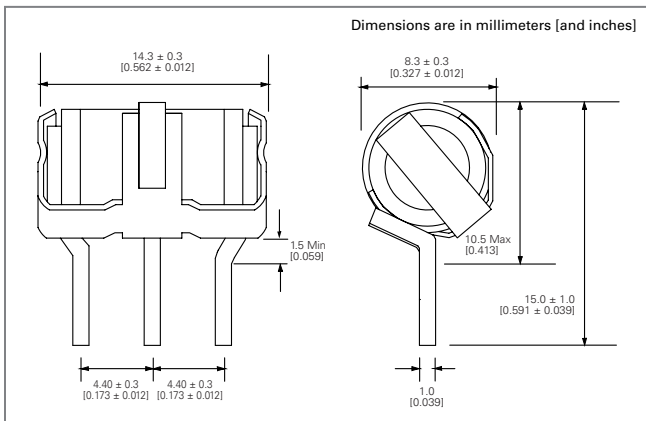

**Packaging Dimensions**

**For Radial Lead Items: Packed in tray (100 pcs)**

**Part Numbering System and Ordering Information**

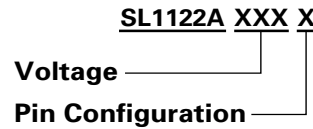

### Soldering Parameters - Reflow Soldering

|  |                                    |                         |
|--|------------------------------------|-------------------------|
| Reflow Condition                                       |                                    | Pb-free assembly        |
| Pre Heat   | - Temperature Min ( $T_{s(min)}$ ) | 150°C                   |
|  | - Temperature Max ( $T_{s(max)}$ ) | 200°C                   |
|  | - Time (Min to Max) ( $t_s$ )      | 60 – 180 seconds        |
| Average Ramp-up Rate (Liquidus Temp ( $T_L$ ) to peak) |                                    | 3°C/second max.         |
| $T_{s(max)}$ to $T_L$ - Ramp-up Rate                   |                                    | 5°C/second max.         |
| Reflow   | - Temperature ( $T_L$ ) (Liquidus) | 217°C                   |
|  | - Temperature ( $t_L$ )            | 60 – 150 seconds        |
| Peak Temperature ( $T_p$ )                             |                                    | 260 <sup>+0/-5</sup> °C |
| Time within 5°C of Actual Peak Temperature ( $t_p$ )   |                                    | 10 – 30 seconds         |
| Ramp-down Rate   |                                    | 6°C/second max.         |
| Time 25°C to Peak Temperature ( $T_p$ )                |                                    | 8 minutes max.          |
| Do not exceed  |                                    | 260°C                   |

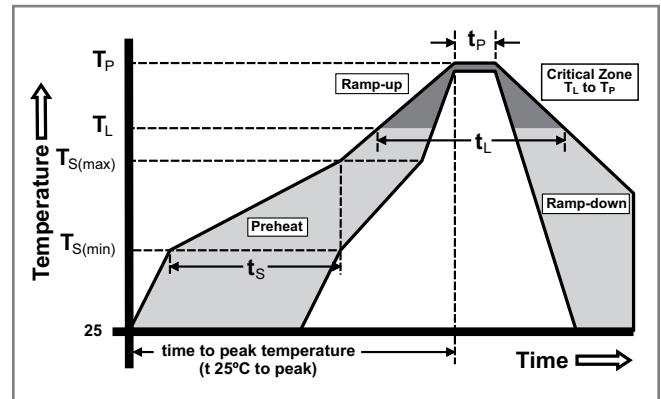

\* Devices that are soldered require inspection before use.

### Soldering Parameters - Wave Soldering (Thru-Hole Devices)

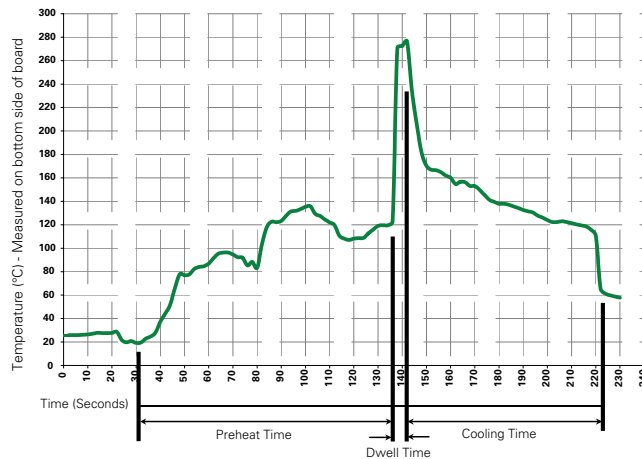

### Recommended Process Parameters:

| Wave Parameter  | Lead-Free Recommendation |
|---|--------------------------|
| <b>Preheat:</b><br>(Depends on Flux Activation Temperature) (Typical Industry Recommendation) |                          |
| Temperature Minimum:  | 100° C                   |
| Temperature Maximum:  | 150° C                   |
| Preheat Time:   | 60-180 seconds           |
| <b>Solder Pot Temperature:</b> 280° C Maximum   |                          |
| Solder Dwell Time:  | 2-5 seconds              |

### Soldering Parameters - Hand Soldering

Solder Iron Temperature: 350° C +/- 5°C  
 Heating Time: 5 seconds max.



Компания «ЭлектроПласт» предлагает заключение долгосрочных отношений при поставках импортных электронных компонентов на взаимовыгодных условиях!

Наши преимущества:

- Оперативные поставки широкого спектра электронных компонентов отечественного и импортного производства напрямую от производителей и с крупнейших мировых складов;
- Поставка более 17-ти миллионов наименований электронных компонентов;
- Поставка сложных, дефицитных, либо снятых с производства позиций;
- Оперативные сроки поставки под заказ (от 5 рабочих дней);
- Экспресс доставка в любую точку России;
- Техническая поддержка проекта, помощь в подборе аналогов, поставка прототипов;
- Система менеджмента качества сертифицирована по Международному стандарту ISO 9001;
- Лицензия ФСБ на осуществление работ с использованием сведений, составляющих государственную тайну;
- Поставка специализированных компонентов (Xilinx, Altera, Analog Devices, Intersil, Interpoint, Microsemi, Aeroflex, Peregrine, Syfer, Eurofarad, Texas Instrument, Miteq, Cobham, E2V, MA-COM, Hittite, Mini-Circuits, General Dynamics и др.);

Помимо этого, одним из направлений компании «ЭлектроПласт» является направление «Источники питания». Мы предлагаем Вам помощь Конструкторского отдела:

- Подбор оптимального решения, техническое обоснование при выборе компонента;
- Подбор аналогов;
- Консультации по применению компонента;
- Поставка образцов и прототипов;
- Техническая поддержка проекта;
- Защита от снятия компонента с производства.



#### Как с нами связаться

**Телефон:** 8 (812) 309 58 32 (многоканальный)

**Факс:** 8 (812) 320-02-42

**Электронная почта:** [org@eplast1.ru](mailto:org@eplast1.ru)

**Адрес:** 198099, г. Санкт-Петербург, ул. Калинина, дом 2, корпус 4, литера А.