

REV	DATE	DESCRIPTION	BY	APPD
A17	ECR-14-012603		10SEP2004	SK MKO
A18	ECR-14-014129		29SEP2004	SK MKO
A19	ECR-15-000619		21AUG2005	GSK MKO
A20	ECR-16-016696		18SEP2007	GR MKO
A21	REVISED PER ECR-16-016780		30JAN2018	SRG MKO

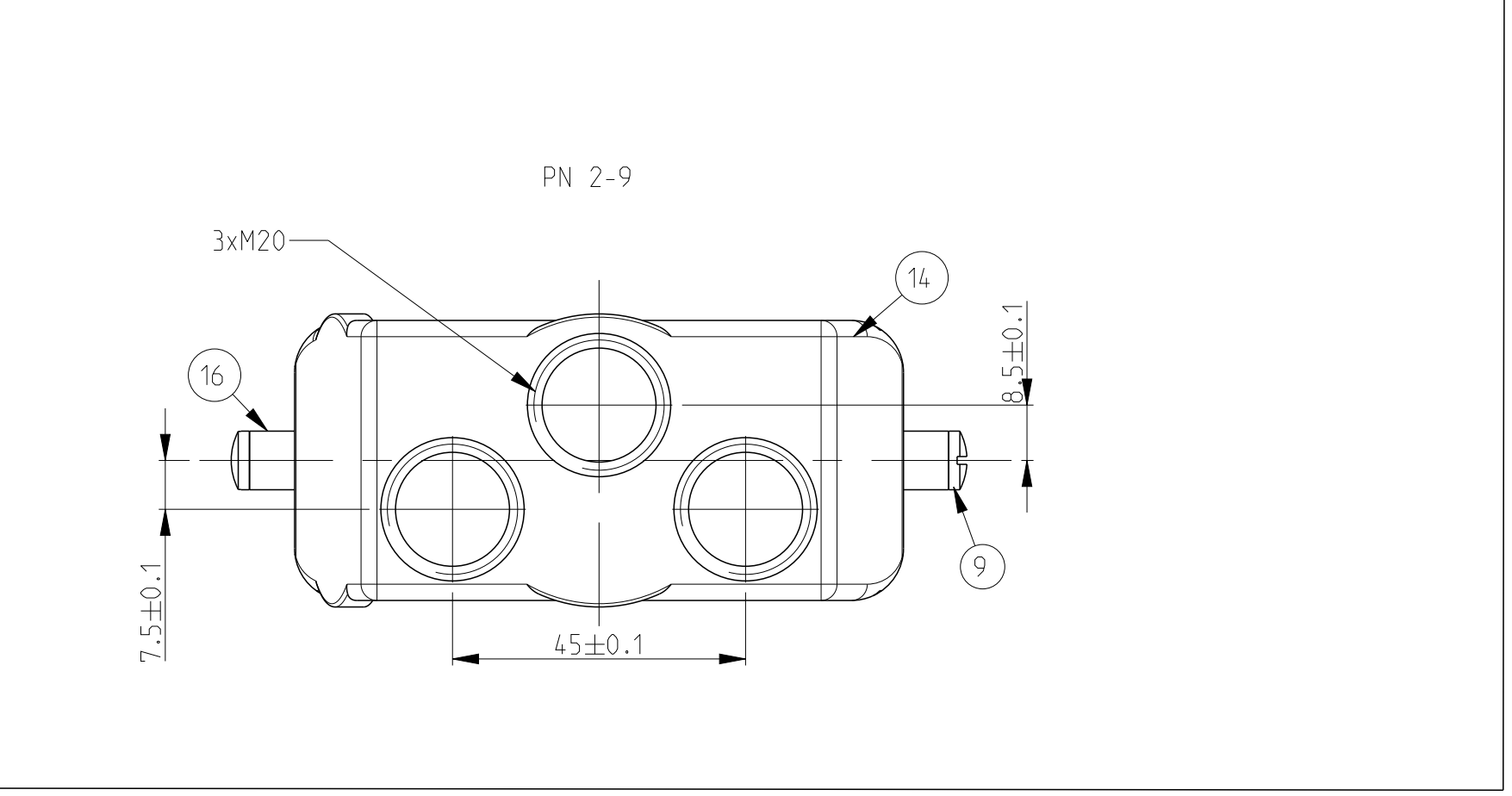
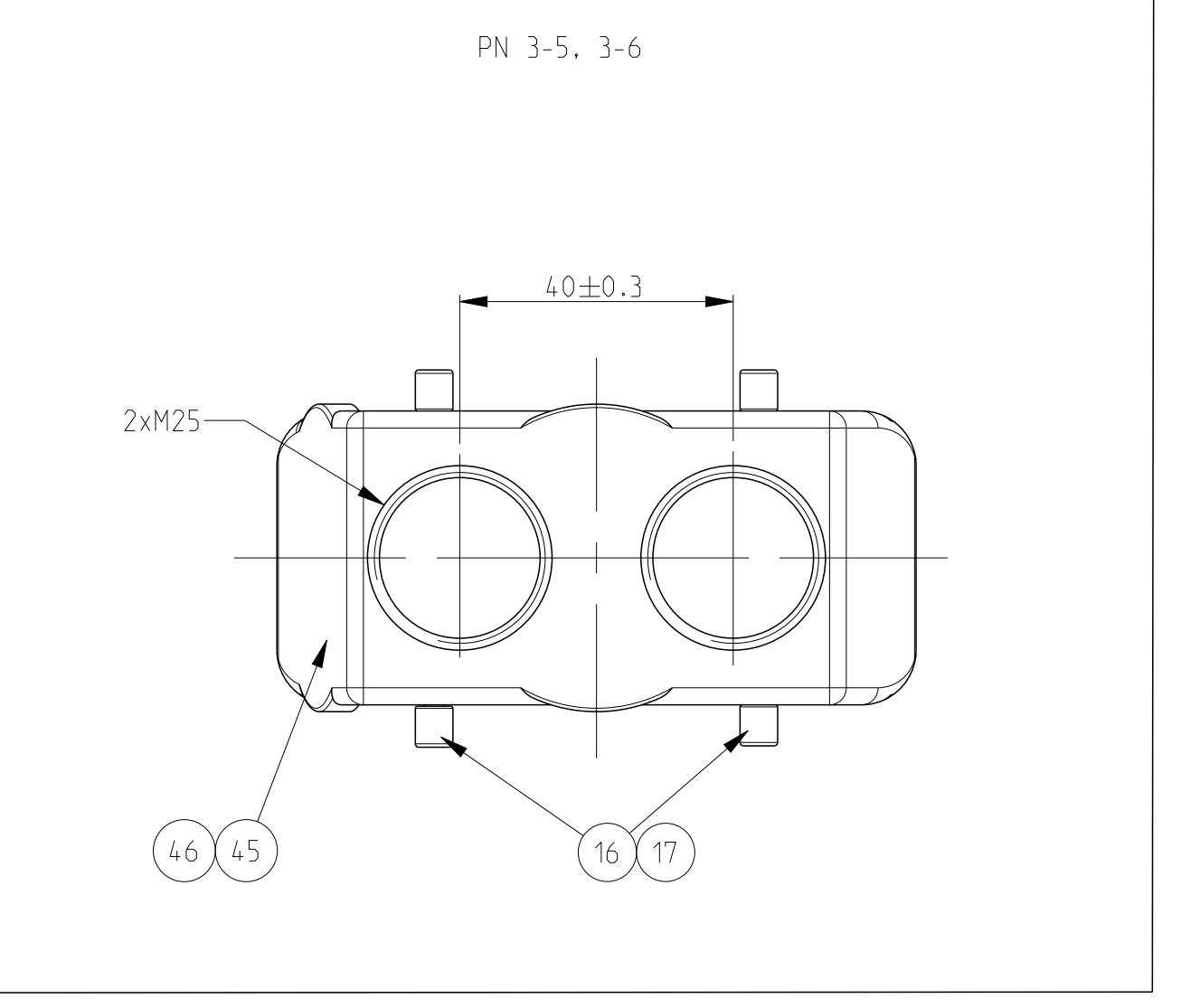
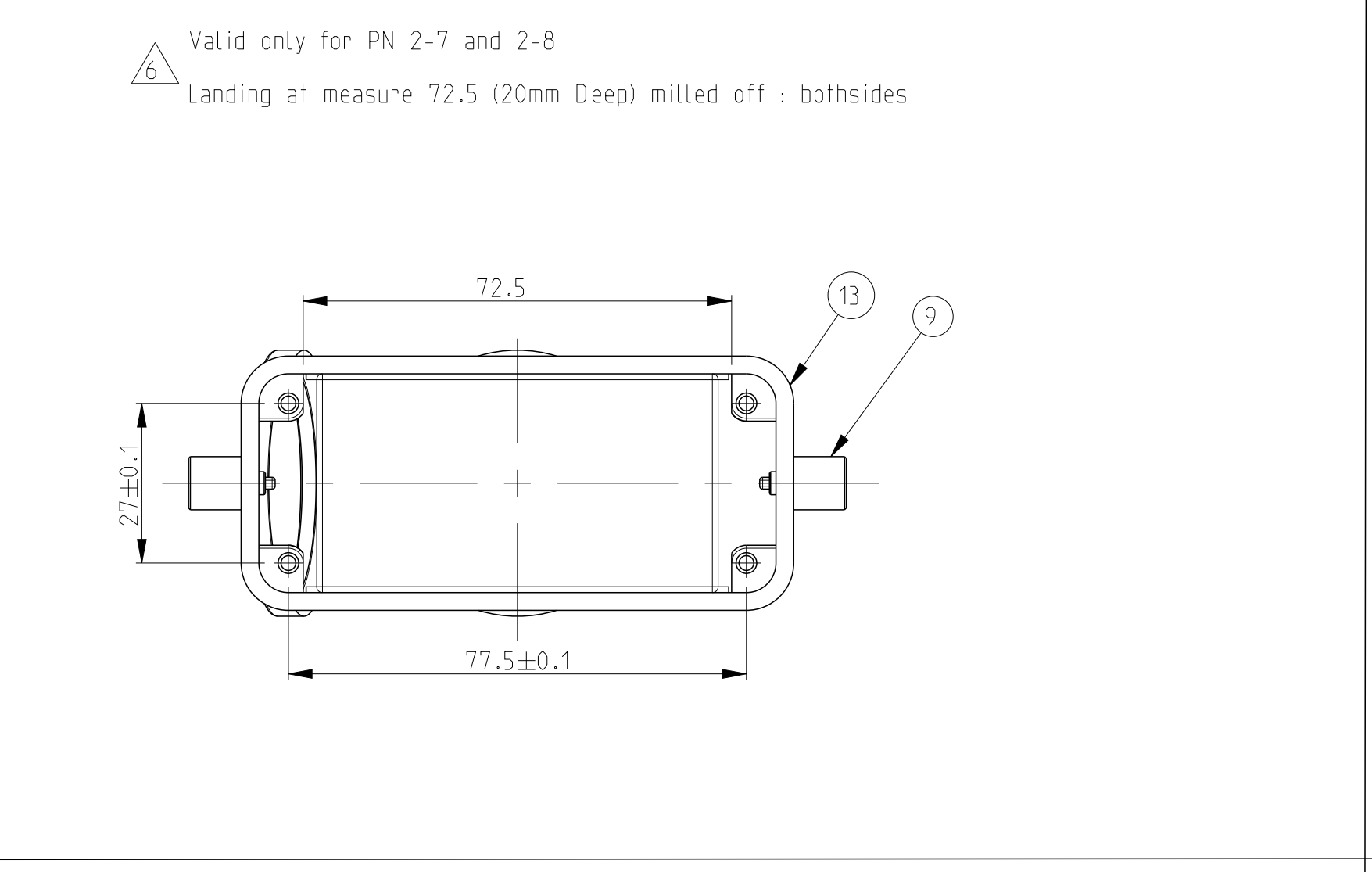
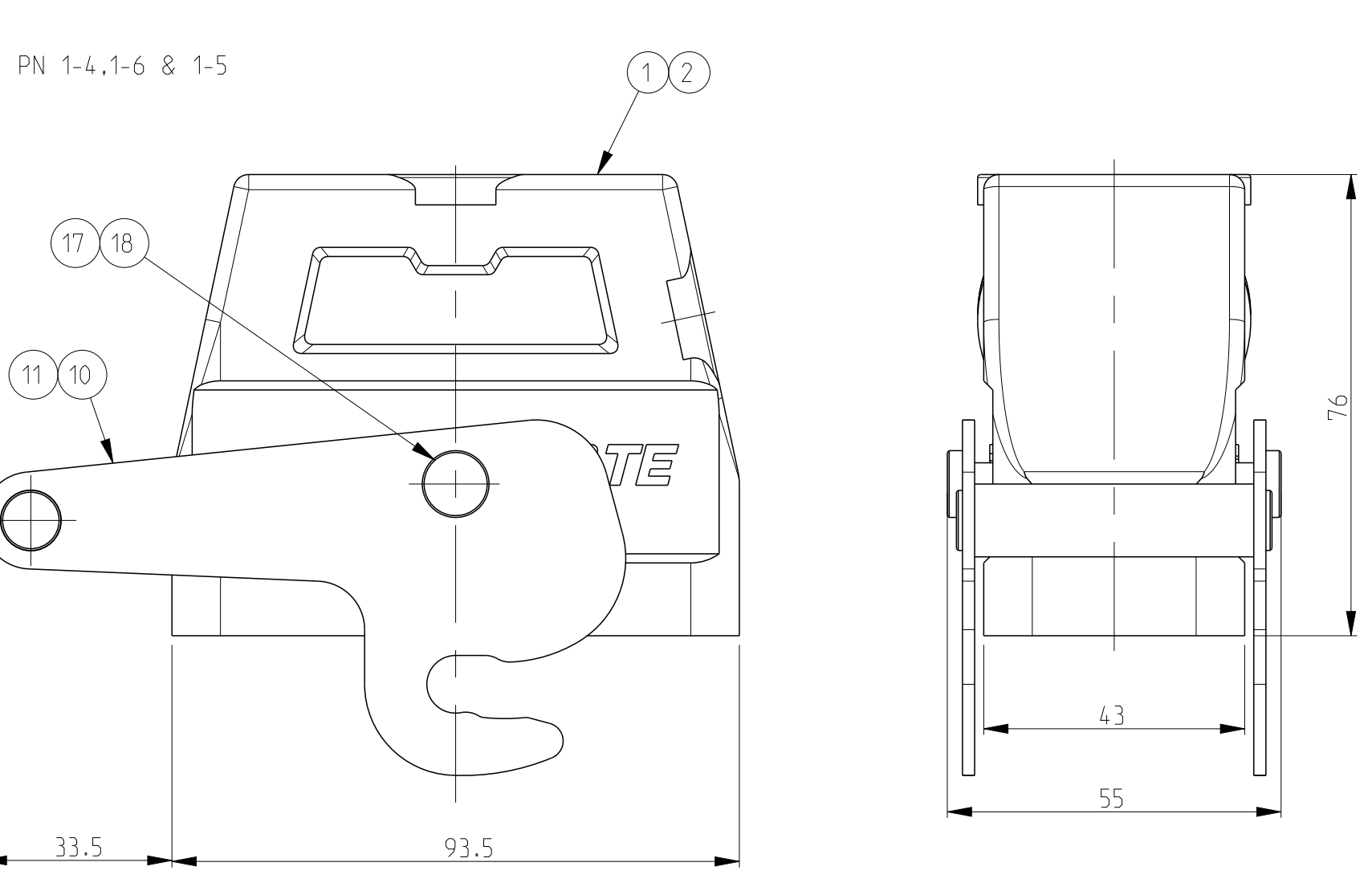
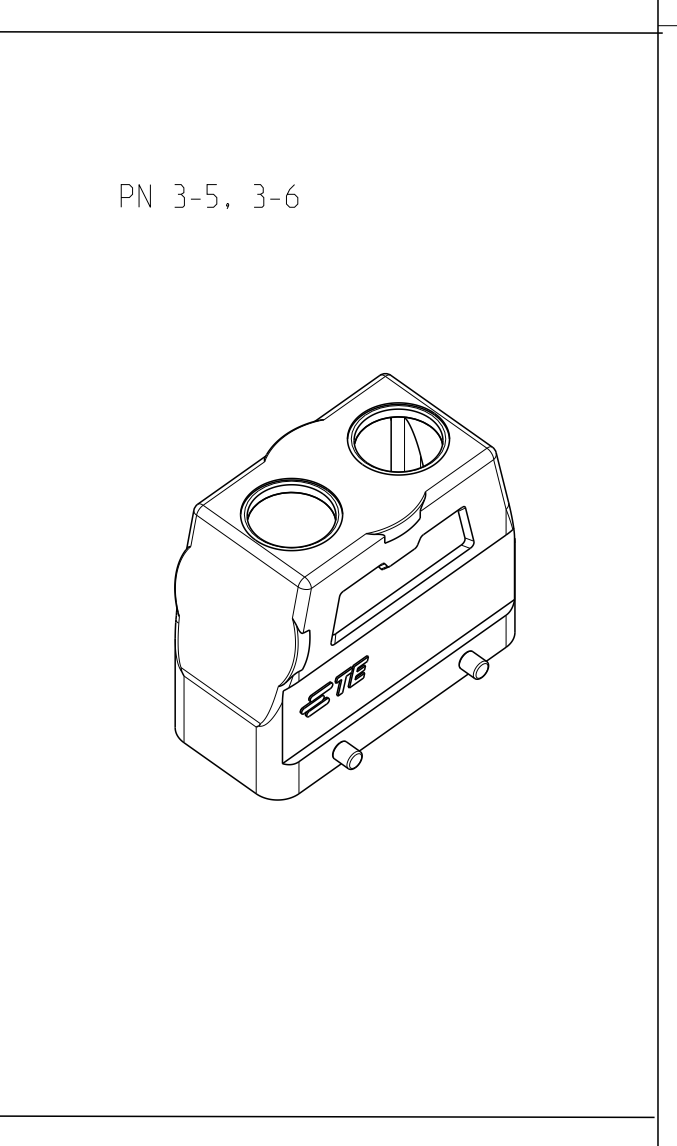
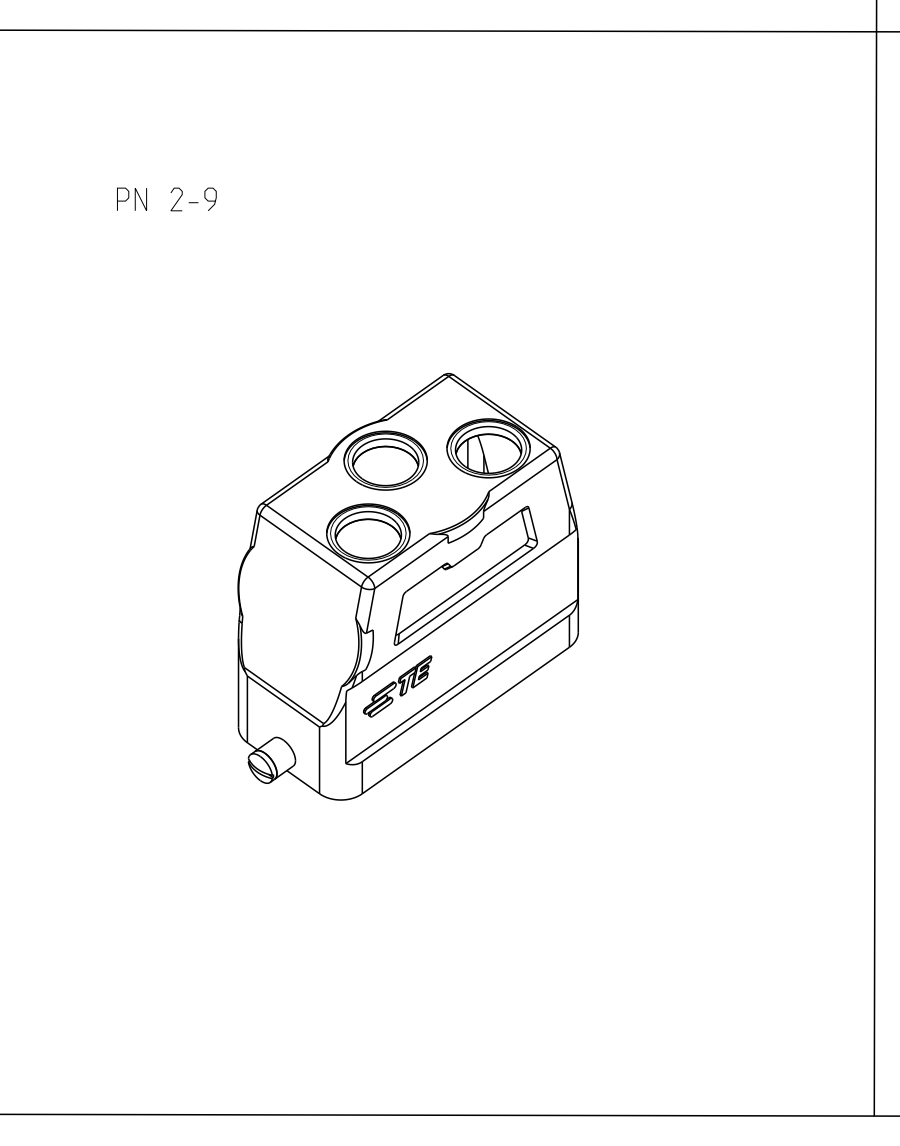
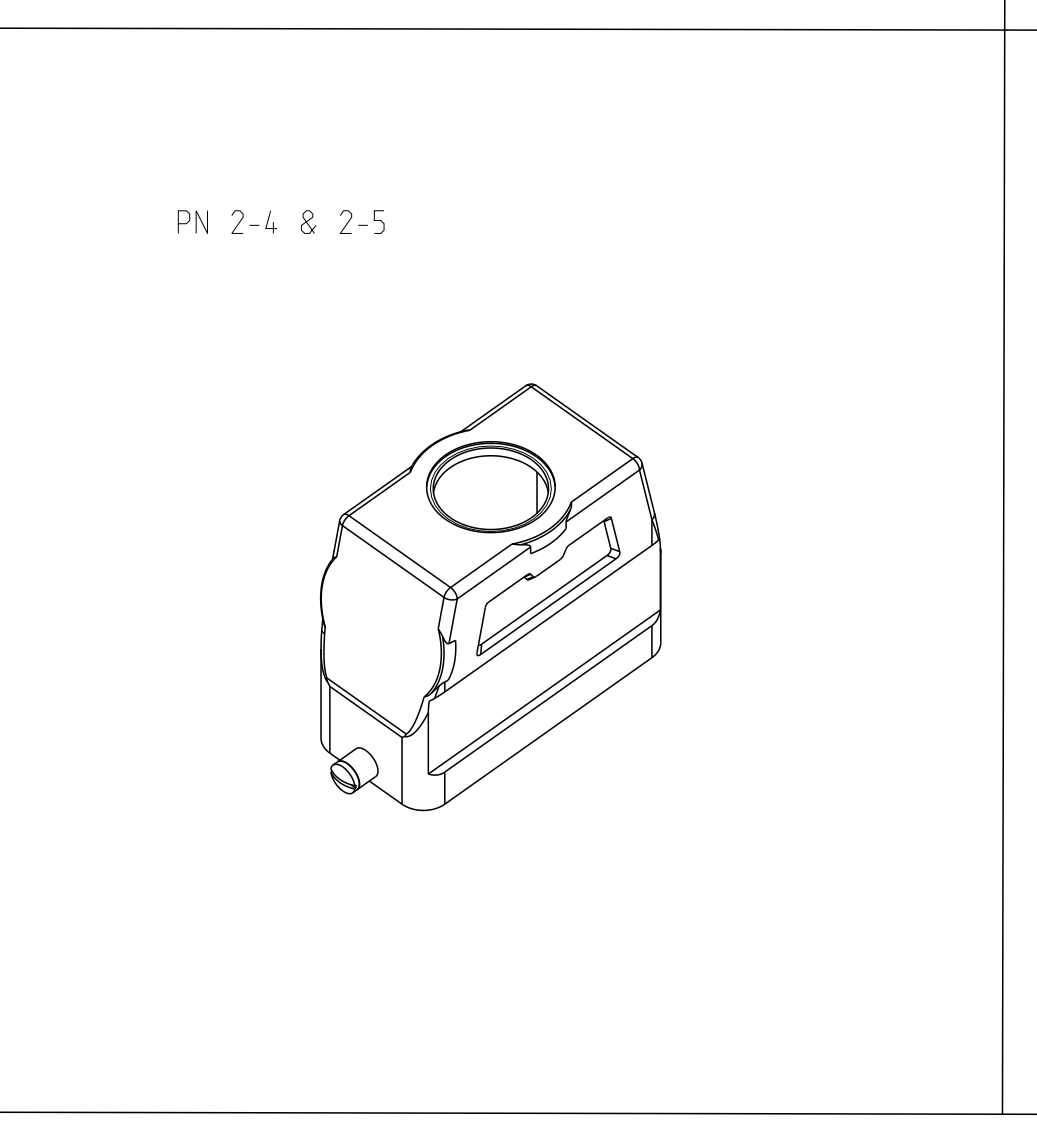
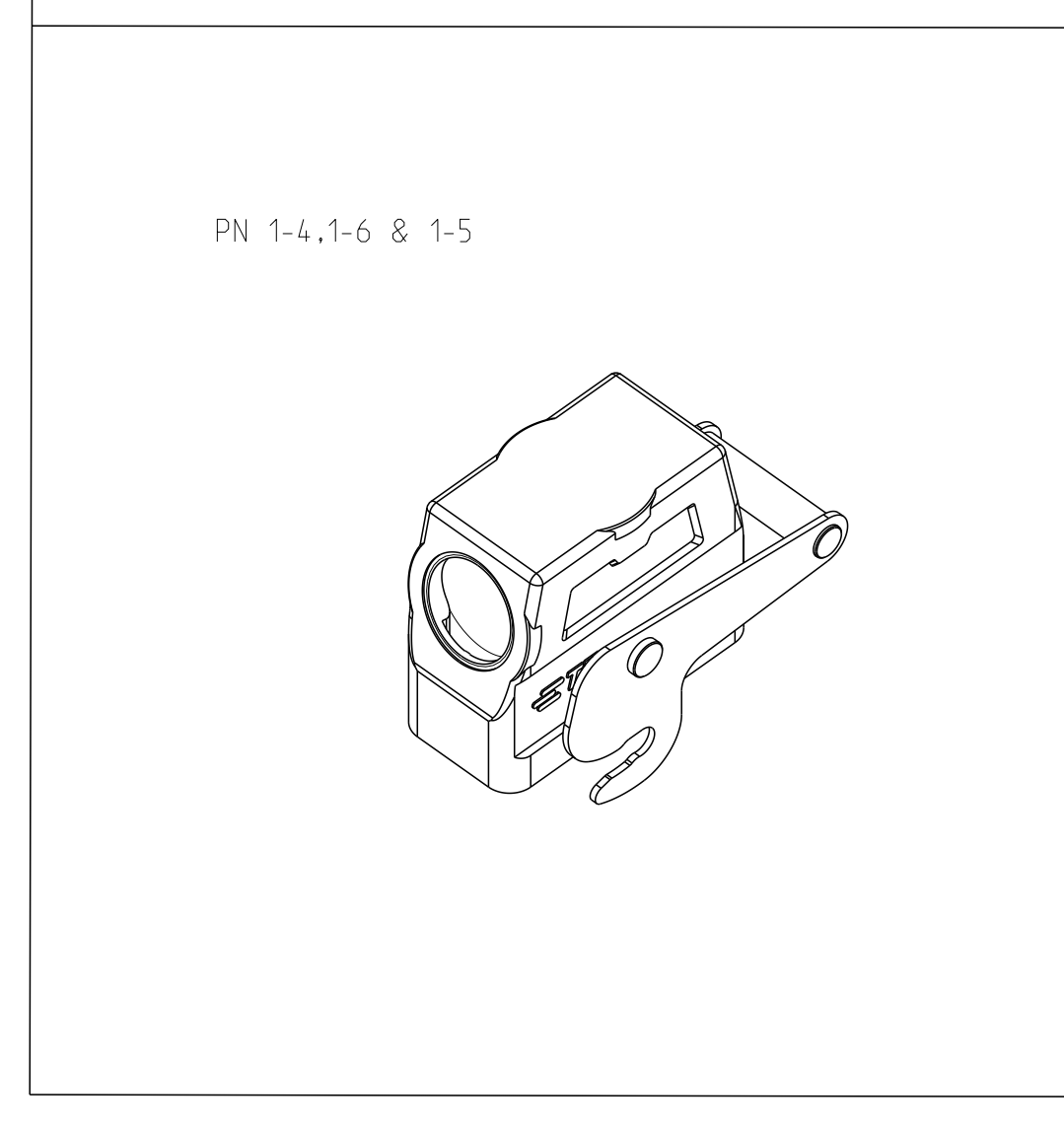
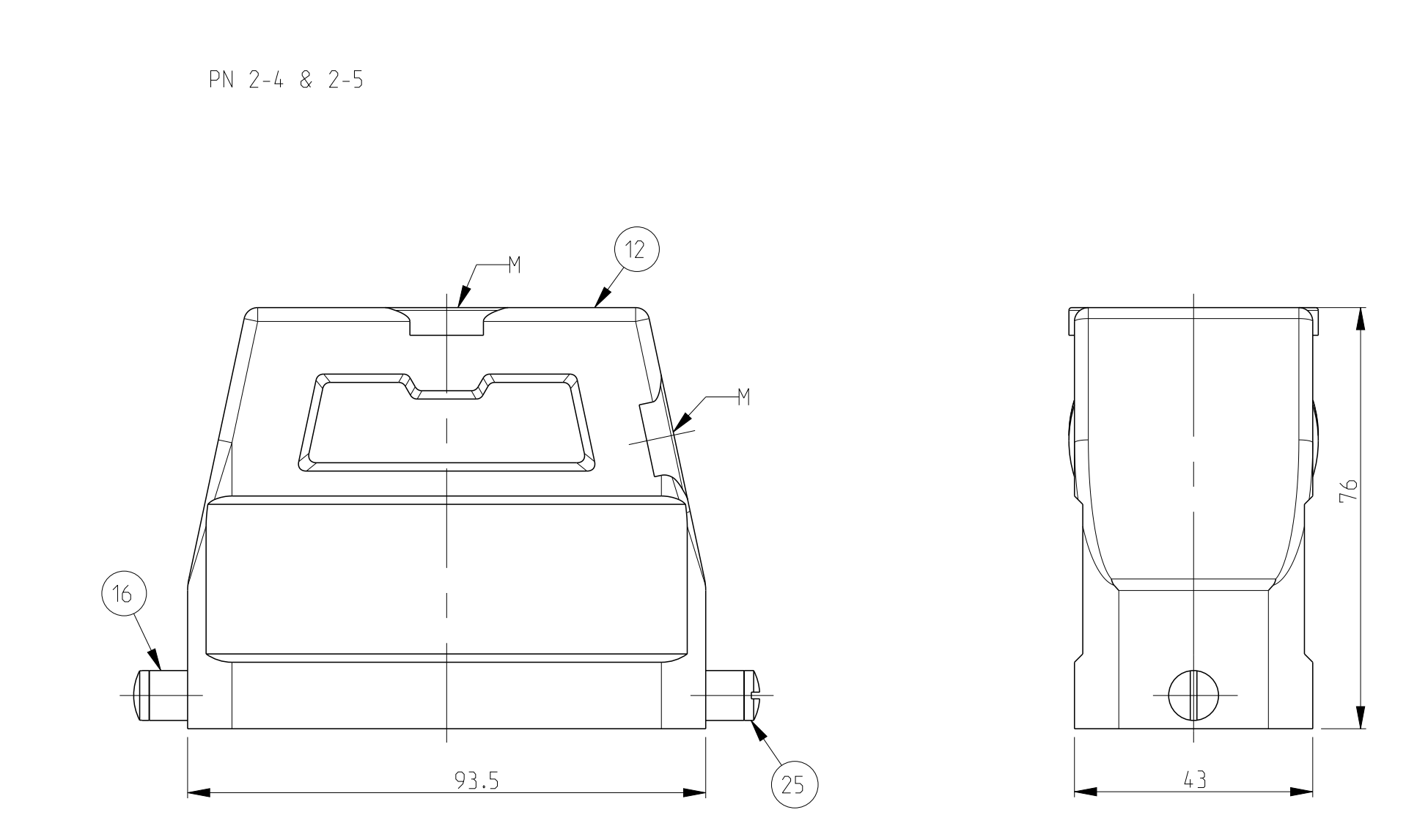
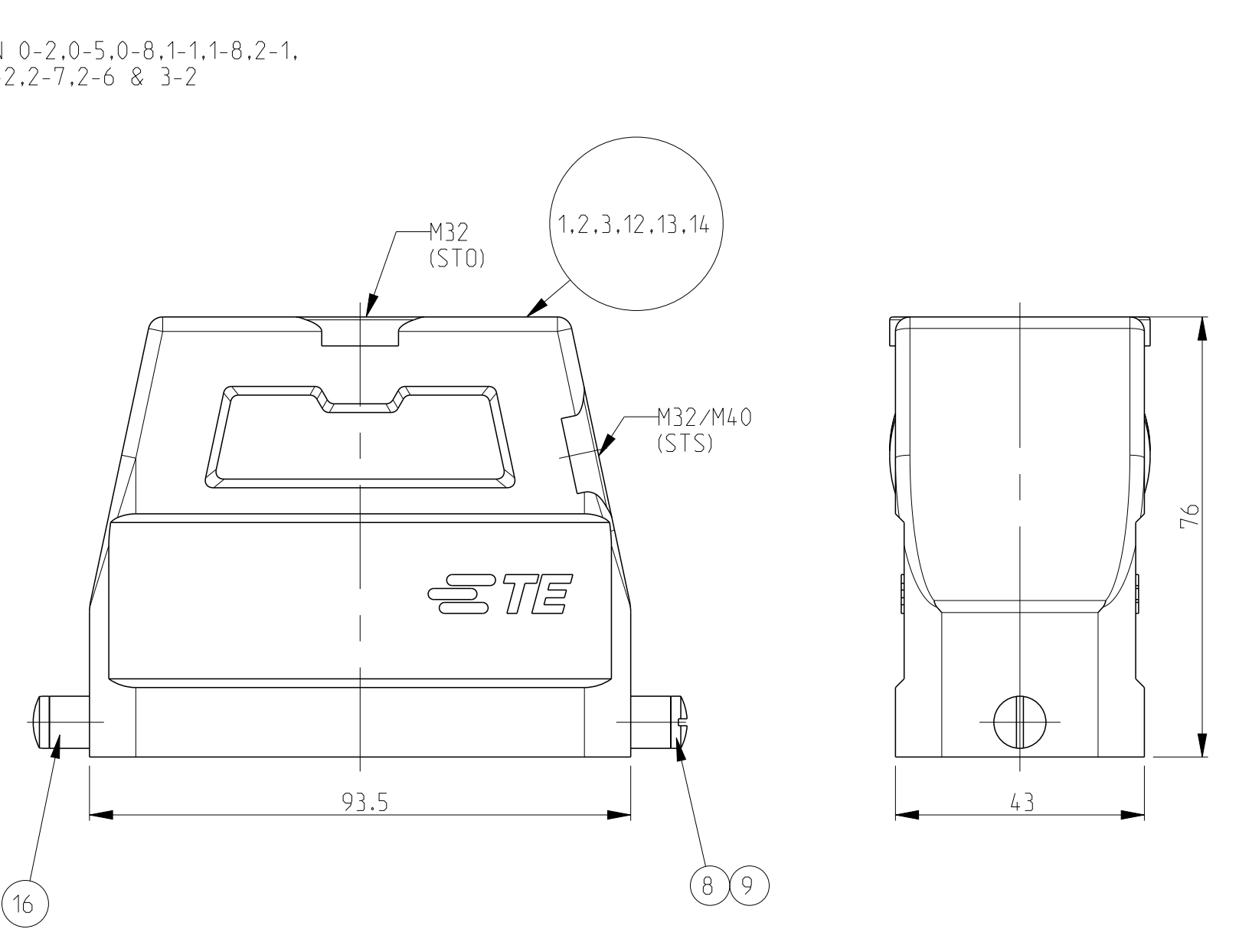
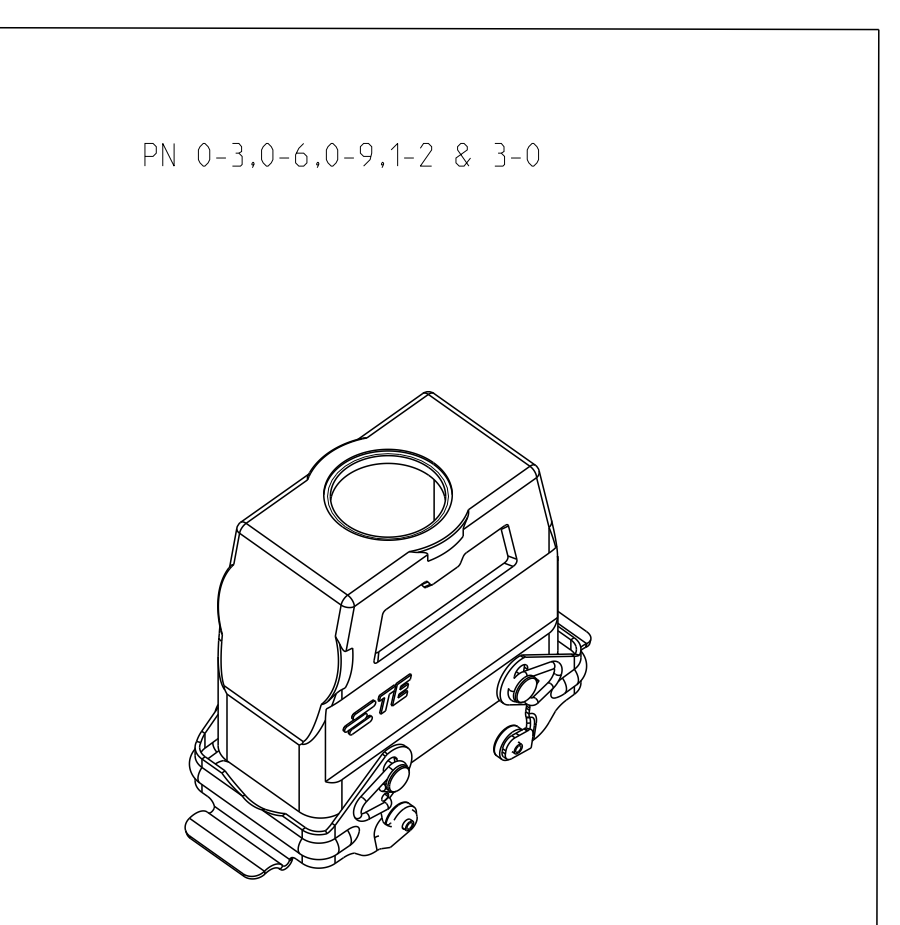
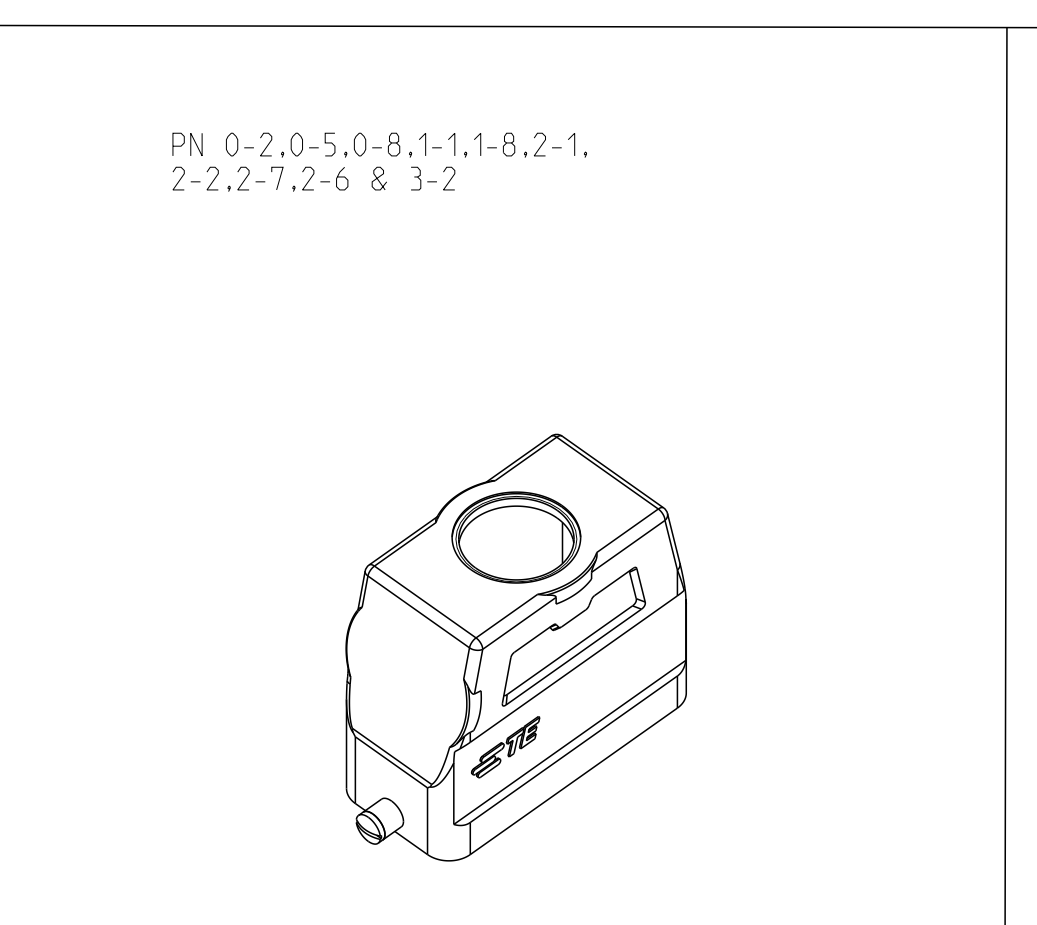
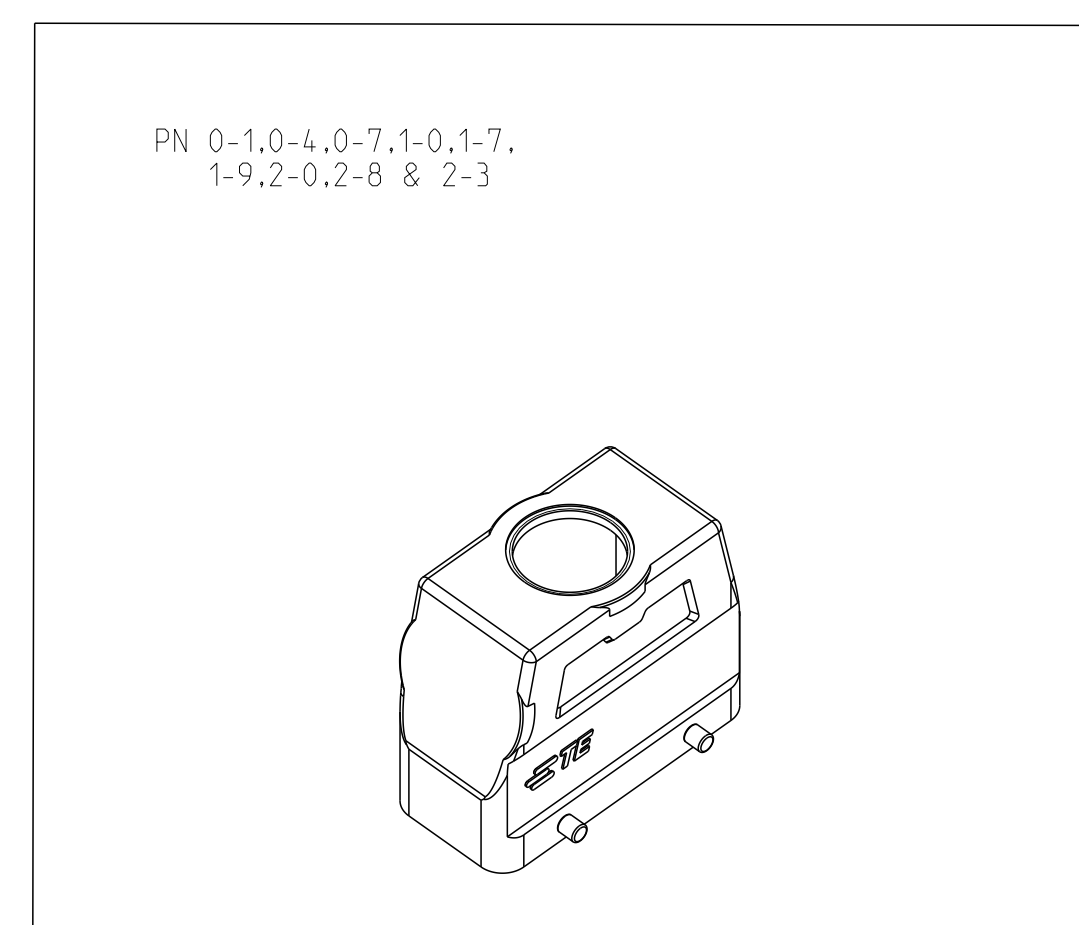
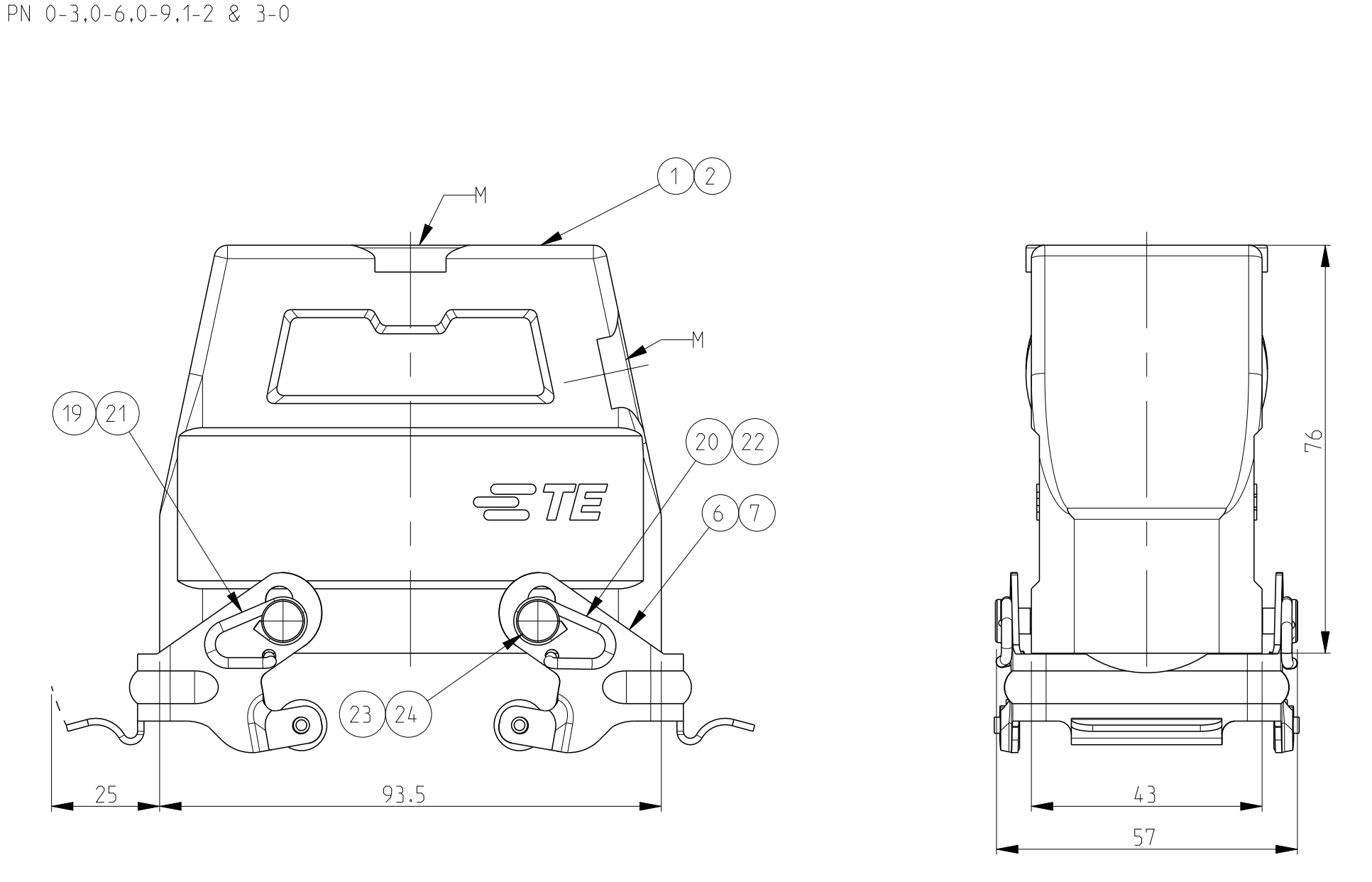
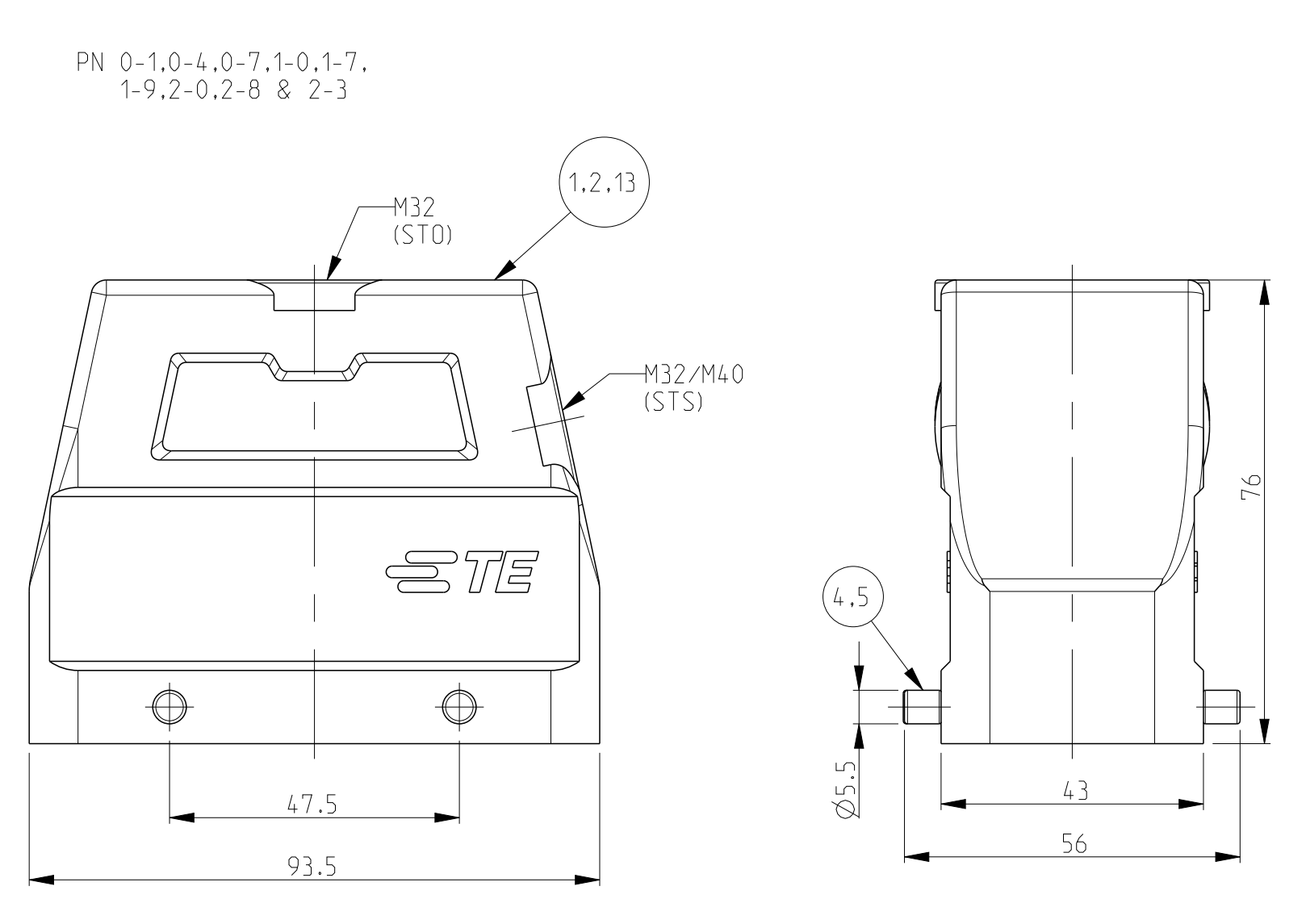

- NOTES
- ▲ MATERIAL-HOUSING ALUMINIUM DIECASTING ALLOY
 - ▲ SURFACE-POWDER VARNISH-GREY - VARNISH BLACK
 - 3 VARNISH ON THE INSIDE NOT NECESSARY
 - ▲ WITH OUT TE LOGO
 - ▲ PACKAGING QUANTITY 5 PIECES IN A BOX

REV	DATE	DESCRIPTION	BY	APPD	MATERIAL	SURFACE	COLOR	ITEM NO	NOTES
1					LD-K HOOD	ALUMINIUM	BLANK	47	M5
1					HD HOOD	ALUMINIUM	BLACK	46	
1					HD HOOD	ALUMINIUM	GREY	45	
1					HD HOOD	ALUMINIUM		44	W ITHOUT LOGO&DRILLING
1					HD HOOD	ALUMINIUM		43	W ITHOUT LOGO&DRILLING
1					HD HOOD	ALUMINIUM	GREY	42	
1					HD HOOD	ALUMINIUM	UNPAINTED	41	SINGLE PART
1					HD HOOD	ALUMINIUM	GREY	40	3xM20
1					LD-K HOOD	ALUMINIUM	BLANK	39	M5
1					HD HOOD	ALUMINIUM	ZINC PLATED	38	
1					HD HOOD	ALUMINIUM	ALUMINIUM OXIDE	37	
1					HD HOOD	ALUMINIUM	ALUMINIUM OXIDE	36	W ITH OUT TE-LOGO
1					HD HOOD	ALUMINIUM	GREY	35	W ITH OUT TE-LOGO
1					HD HOOD	ALUMINIUM	GREY	34	W ITH OUT TE-LOGO
1					HD HOOD	ALUMINIUM	GREY	33	W ITH OUT TE-LOGO
1					HD HOOD	ALUMINIUM	GREY	32	
1					ZB-CLIP POSITIONER	STEEL	ZINC PLATED	31	
1					ZB-CLIP POSITIONER	STEEL	BLANK	30	
1					ZB-LOCKING CLIP	STEEL	ZINC PLATED	29	
1					LD-K HOOD	ALUMINIUM	ZINC PLATED	28	
1					LD-K HOOD	ALUMINIUM	BLANK	27	
1					LD-K HOOD	ALUMINIUM	ZINC PLATED	26	
1					LD-K HOOD	ALUMINIUM	BLANK	25	
1					LD-K HOOD	ALUMINIUM	ZINC PLATED	24	
1					LD-K HOOD	ALUMINIUM	BLANK	23	
1					LD-K HOOD	ALUMINIUM	ZINC PLATED	22	
1					LD-K HOOD	ALUMINIUM	BLANK	21	
1					LD-K HOOD	ALUMINIUM	ZINC PLATED	20	
1					LD-K HOOD	ALUMINIUM	BLANK	19	
1					LD-K HOOD	ALUMINIUM	ZINC PLATED	18	
1					LD-K HOOD	ALUMINIUM	BLANK	17	
1					LD-K HOOD	ALUMINIUM	ZINC PLATED	16	
1					LD-K HOOD	ALUMINIUM	GREY	15	W ITH OUT TE-LOGO
1					LD-K HOOD	ALUMINIUM	GREY	14	W ITH OUT TE-LOGO
1					LD-K HOOD	ALUMINIUM	GREY	13	W ITH OUT TE-LOGO
1					LD-K HOOD	ALUMINIUM	GREY	12	W ITH OUT TE-LOGO
1					LD-K HOOD	ALUMINIUM	GREY	11	
1					LD-K HOOD	ALUMINIUM	GREY	10	
1					LD-K HOOD	ALUMINIUM	ALUMINIUM OXIDE	9	
1					LD-K HOOD	ALUMINIUM	ALUMINIUM OXIDE	8	
1					LD-K HOOD	ALUMINIUM	ALUMINIUM OXIDE	7	
1					LD-K HOOD	ALUMINIUM	ALUMINIUM OXIDE	6	
1					LD-K HOOD	ALUMINIUM	ALUMINIUM OXIDE	5	
1					LD-K HOOD	ALUMINIUM	GREY	4	
1					LD-K HOOD	ALUMINIUM	GREY	3	
1					LD-K HOOD	ALUMINIUM	GREY	2	
1					LD-K HOOD	ALUMINIUM	GREY	1	

REV	DATE	DESCRIPTION	BY	APPD	MATERIAL	SURFACE	COLOR	ITEM NO	NOTES
1					LD-K HOOD	ALUMINIUM	BLANK	47	M5
1					HD HOOD	ALUMINIUM	BLACK	46	
1					HD HOOD	ALUMINIUM	GREY	45	
1					HD HOOD	ALUMINIUM		44	W ITHOUT LOGO&DRILLING
1					HD HOOD	ALUMINIUM		43	W ITHOUT LOGO&DRILLING
1					HD HOOD	ALUMINIUM	GREY	42	
1					HD HOOD	ALUMINIUM	UNPAINTED	41	SINGLE PART
1					HD HOOD	ALUMINIUM	GREY	40	3xM20
1					LD-K HOOD	ALUMINIUM	BLANK	39	M5
1					HD HOOD	ALUMINIUM	ZINC PLATED	38	
1					HD HOOD	ALUMINIUM	ALUMINIUM OXIDE	37	
1					HD HOOD	ALUMINIUM	ALUMINIUM OXIDE	36	W ITH OUT TE-LOGO
1					HD HOOD	ALUMINIUM	GREY	35	W ITH OUT TE-LOGO
1					HD HOOD	ALUMINIUM	GREY	34	W ITH OUT TE-LOGO
1					HD HOOD	ALUMINIUM	GREY	33	W ITH OUT TE-LOGO
1					HD HOOD	ALUMINIUM	GREY	32	
1					ZB-CLIP POSITIONER	STEEL	ZINC PLATED	31	
1					ZB-CLIP POSITIONER	STEEL	BLANK	30	
1					ZB-LOCKING CLIP	STEEL	ZINC PLATED	29	
1					LD-K HOOD	ALUMINIUM	ZINC PLATED	28	
1					LD-K HOOD	ALUMINIUM	BLANK	27	
1					LD-K HOOD	ALUMINIUM	ZINC PLATED	26	
1					LD-K HOOD	ALUMINIUM	BLANK	25	
1					LD-K HOOD	ALUMINIUM	ZINC PLATED	24	
1					LD-K HOOD	ALUMINIUM	BLANK	23	
1					LD-K HOOD	ALUMINIUM	ZINC PLATED	22	
1					LD-K HOOD	ALUMINIUM	BLANK	21	
1					LD-K HOOD	ALUMINIUM	ZINC PLATED	20	
1					LD-K HOOD	ALUMINIUM	BLANK	19	
1					LD-K HOOD	ALUMINIUM	ZINC PLATED	18	
1					LD-K HOOD	ALUMINIUM	BLANK	17	
1					LD-K HOOD	ALUMINIUM	ZINC PLATED	16	
1					LD-K HOOD	ALUMINIUM	GREY	15	W ITH OUT TE-LOGO
1					LD-K HOOD	ALUMINIUM	GREY	14	W ITH OUT TE-LOGO
1					LD-K HOOD	ALUMINIUM	GREY	13	W ITH OUT TE-LOGO
1					LD-K HOOD	ALUMINIUM	GREY	12	W ITH OUT TE-LOGO
1					LD-K HOOD	ALUMINIUM	GREY	11	
1					LD-K HOOD	ALUMINIUM	GREY	10	
1					LD-K HOOD	ALUMINIUM	ALUMINIUM OXIDE	9	
1					LD-K HOOD	ALUMINIUM	ALUMINIUM OXIDE	8	
1					LD-K HOOD	ALUMINIUM	ALUMINIUM OXIDE	7	
1					LD-K HOOD	ALUMINIUM	ALUMINIUM OXIDE	6	
1					LD-K HOOD	ALUMINIUM	ALUMINIUM OXIDE	5	
1					LD-K HOOD	ALUMINIUM	GREY	4	
1					LD-K HOOD	ALUMINIUM	GREY	3	
1					LD-K HOOD	ALUMINIUM	GREY	2	
1					LD-K HOOD	ALUMINIUM	GREY	1	



Компания «ЭлектроПласт» предлагает заключение долгосрочных отношений при поставках импортных электронных компонентов на взаимовыгодных условиях!

Наши преимущества:

- Оперативные поставки широкого спектра электронных компонентов отечественного и импортного производства напрямую от производителей и с крупнейших мировых складов;
- Поставка более 17-ти миллионов наименований электронных компонентов;
- Поставка сложных, дефицитных, либо снятых с производства позиций;
- Оперативные сроки поставки под заказ (от 5 рабочих дней);
- Экспресс доставка в любую точку России;
- Техническая поддержка проекта, помощь в подборе аналогов, поставка прототипов;
- Система менеджмента качества сертифицирована по Международному стандарту ISO 9001;
- Лицензия ФСБ на осуществление работ с использованием сведений, составляющих государственную тайну;
- Поставка специализированных компонентов (Xilinx, Altera, Analog Devices, Intersil, Interpoint, Microsemi, Aeroflex, Peregrine, Syfer, Eurofarad, Texas Instrument, Miteq, Cobham, E2V, MA-COM, Hittite, Mini-Circuits, General Dynamics и др.);

Помимо этого, одним из направлений компании «ЭлектроПласт» является направление «Источники питания». Мы предлагаем Вам помощь Конструкторского отдела:

- Подбор оптимального решения, техническое обоснование при выборе компонента;
- Подбор аналогов;
- Консультации по применению компонента;
- Поставка образцов и прототипов;
- Техническая поддержка проекта;
- Защита от снятия компонента с производства.



Как с нами связаться

Телефон: 8 (812) 309 58 32 (многоканальный)

Факс: 8 (812) 320-02-42

Электронная почта: org@eplast1.ru

Адрес: 198099, г. Санкт-Петербург, ул. Калинина, дом 2, корпус 4, литера А.