



## Multichannel 96 kHz Codec

## Preliminary Technical Data

AD1836

## FEATURES

**5 V Multichannel Audio System**  
**Accepts 16-/18-/20-/24-Bit Data**  
**Supports 24 Bits and 96 kHz Sample Rate**  
**Multibit Sigma-Delta Modulators with Data Directed Scrambling**  
**Data-Directed Scrambling ADCs and DACs—Least Sensitive to Jitter**  
**Differential Output for Optimum Performance**  
**ADCs: -92 dB THD + N, 105 dB SNR and Dynamic Range**  
**DACs: -95 dB THD + N, 108 dB SNR and Dynamic Range**  
**On-Chip Volume Control with "Auroramp" Function**  
**Programmable Gain Amplifier for ADC Input**  
**Hardware and Software Controllable Clickless Mute**  
**Digital De-Emphasis Processing**  
**Supports  $256 \times f_s$ ,  $512 \times f_s$ , or  $768 \times f_s$  Master Clock**  
**Power-Down Mode Plus Soft Power-Down Mode**  
**Flexible Serial Data Port with Right-Justified, Left-Justified, I<sup>2</sup>S-Compatible and DSP Serial Port Modes**  
**TDM Interface Mode Supports 8 In/8 Out Using a Single SHARC<sup>®</sup> SPORT**  
**52-Lead MQFP (PQFP) Plastic Package**

## APPLICATIONS

**Home Theatre Systems**  
**Automotive Audio Systems**  
**DVD**  
**Set-Top Boxes**  
**Digital Audio Effects Processors**

## GENERAL DESCRIPTION

The AD1836 is a high-performance, single-chip codec providing three stereo DACs and two stereo ADCs using ADI's patented multibit sigma-delta architecture. An SPI port is included, allowing a microcontroller to adjust volume and many other parameters. The AD1836 operates from a 5 V supply, with provision for a separate output supply to interface with low-voltage external circuitry. The AD1836 is available in a 52-lead MQFP (PQFP) package.

## FUNCTIONAL BLOCK DIAGRAM

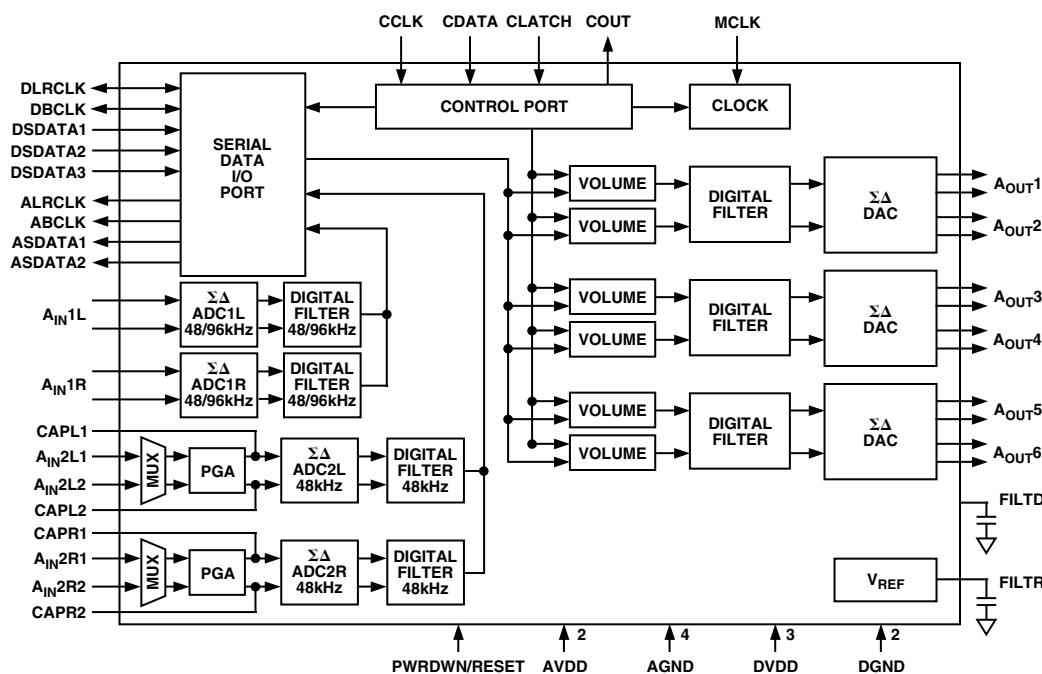

SHARC is a registered trademark of Analog Device, Inc.

REV. PrC

Information furnished by Analog Devices is believed to be accurate and reliable. However, no responsibility is assumed by Analog Devices for its use, nor for any infringements of patents or other rights of third parties which may result from its use. No license is granted by implication or otherwise under any patent or patent rights of Analog Devices.

One Technology Way, P.O. Box 9106, Norwood, MA 02062-9106, U.S.A.  
 Tel: 781/329-4700 World Wide Web Site: [www.analog.com](http://www.analog.com)  
 Fax: 781/326-8703 © Analog Devices, Inc., 2001

# AD1836—SPECIFICATIONS

## TEST CONDITIONS UNLESS OTHERWISE NOTED

Supply Voltages (AVDD, DVDD)	5.0 V
Ambient Temperature	25°C
Master Clock	12.288 MHz, (48 kHz $f_S$ , 256 × $f_S$ Mode)
Input Signal	1.000 kHz, 0 dBFS (Full Scale)
Input Sample Rate	48 kHz
Measurement Bandwidth	20 Hz to 20 kHz
Word Width	20 Bits
Load Capacitance	100 pF
Load Impedance	47 kΩ
Input Voltage HI	2.4 V
Input Voltage LO	0.8 V

### NOTE

Performance of all channels are identical (exclusive of the Interchannel Gain Mismatch and Interchannel Phase Deviation specifications).

## ANALOG PERFORMANCE

	Min	Typ	Max	Unit
<b>ANALOG-TO-DIGITAL CONVERTERS</b>				
ADC Resolution (all ADCs)		24		Bits
Dynamic Range (20 Hz to 20 kHz, -60 dB Input)				
No Filter		102		dB
With A-Weighted Filter		105		dB
Total Harmonic Distortion + Noise		-92		dB
Interchannel Isolation		100		dB
Interchannel Gain Mismatch		0.01		dB
Programmable Input Gain		12		dB
Gain Step Size		3		dB
Offset Error				LSB
Full-Scale Input Voltage At Each Pin (Single-Ended)		1.0 (2.8)		V rms (V p-p)
Gain Drift		100		ppm/°C
Input Resistance	10			kΩ
Input Capacitance			15	pF
Common-Mode Input Volts		2.25		V
<b>DIGITAL-TO-ANALOG CONVERTERS</b>				
Dynamic Range (20 Hz to 20 kHz, -60 dB Input)				
No Filter		105		dB
With A-Weighted Filter		108		dB
Total Harmonic Distortion + Noise		-95		dB
Interchannel Isolation		100		dB
Interchannel Gain Mismatch		0.01(0.12)		dB (%)
DC Accuracy				%
Gain Error		±3.0		%
Interchannel Gain Mismatch		0.01		dB
Gain Drift		150		ppm/°C
Interchannel Crosstalk (EIAJ Method)		-120		dB
Interchannel Phase Deviation		±0.1		Degrees
Volume Control Step Size (1023 Linear Steps)		0.098		%
Volume Control Range (Max Attenuation)		60		dB
Mute Attenuation		-100		dB
De-Emphasis Gain Error		±0.1		dB
Full-Scale Output Voltage At Each Pin (Single-Ended)		1.0 (2.8)		V rms (V p-p)
Output Resistance At Each Pin		115		Ω
Common-Mode Output		2.25		V

## DIGITAL FILTERS at 44.1 kHz

	Min	Typ	Max	Unit
<b>ADC DECIMATION FILTER</b>				
Pass Band		20		kHz
Pass Band Ripple		±0.0001		dB
Transition Band		22		kHz
Stop Band		24		kHz
Stop Band Attenuation		120		dB
Group Delay		TBD		µs
<b>DAC INTERPOLATION FILTER</b>				
Pass Band		20		kHz
Pass Band Ripple		±0.01		dB
Transition Band		22		kHz
Stop Band		24		kHz
Stop Band Attenuation		70		dB
Group Delay		TBD		µs

## TIMING

Parameter	Min	Max	Unit	Comments	
<b>MASTER CLOCK AND RESET</b>					
$t_{MH}$ MCLK High	min	max	ns	$256 \times f_s$ $512 \times f_s$ $768 \times f_s$	
$t_{ML}$ MCLK Low	min	max	ns		
$t_{MCLK}$ MCLK Period	min	max	ns		
$f_{MCLK}$ MCLK Freq	min	max	ns		
$t_{PDR}$ PD/RST Low	4500		MCLK Periods		Reset to SPI Register Write
<b>SPI PORT</b>					
$t_{CCH}$ CCLK High	min		ns	To CCLK Rising From CCLK Rising To CCLK Rising From CCLK Falling From CCLK Falling From CCLK Falling From CCLK Falling From CCLK Falling From CCLK Falling	
$t_{CCL}$ CCLK Low	min		ns		
$t_{CCP}$ CCLK Period	min		ns		
$t_{CDS}$ CDATA Setup	min		ns		
$t_{CDH}$ CDATA Hold	min		ns		
$t_{CLS}$ CLATCH Setup	min		ns		
$t_{CLH}$ CLATCH Hold	min		ns		
$t_{CODE}$ COUT Enable		max	ns		
$t_{COD}$ COUT Delay		max	ns		
$t_{COH}$ COUT Hold	min		ns		
$t_{COTS}$ COUT Three-State		max	ns		
<b>DAC SERIAL PORT</b>					
Normal Modes					
$t_{DBH}$ DBCLK High	min		ns	To DBCLK Rising From DBCLK Rising To DBCLK Rising From DBCLK Rising From DBCLK Rising	
$t_{DBL}$ DBCLK Low	min		ns		
$t_{DBP}$ DBCLK Period	min		ns		
$f_{DB}$ DBCLK Freq	max		ns		
$t_{DLS}$ DLRCLK Setup	min		ns		
$t_{DLH}$ DLRCLK Hold	min		ns		
$t_{DDS}$ DSDATA Setup	min		ns		
$t_{DDH}$ DSDATA Hold	min		ns		
Packed 128, 256 Modes					
$t_{DBH}$ DBCLK High	min		ns		
$t_{DBL}$ DBCLK Low	min		ns		
$t_{DBP}$ DBCLK Period	min		ns		
$f_{DB}$ DBCLK Freq		max	ns		
$t_{DLS}$ DLRCLK Setup	min		ns		
$t_{DLH}$ DLRCLK Hold	min		ns		
$t_{DDS}$ DSDATA Setup	min		ns		
$t_{DDH}$ DSDATA Hold	min		ns		

## AD1836—SPECIFICATIONS

## TIMING (continued)

Parameter		Min	Max	Unit	Comments
ADC Serial Port					
Normal Modes					
$t_{ABH}$	ABCLK Delay High		max	ns	From MCLK Rising $256 \times f_S$ $512 \times f_S$ $768 \times f_S$
$t_{ABL}$	ABCLK Delay Low		max	ns	From MCLK Rising $256 \times f_S$ $512 \times f_S$ $768 \times f_S$
$t_{ALS}$	LRCLK Delay		max	ns	From ABCLK Falling
$t_{ABDD}$	ASDATA Delay		max	ns	From ABCLK Falling
$t_{ALRDD}$	ASDATA Delay		max	ns	From ALRCLK Changing (Left-Justified)
Packed 128, 256 Modes					
$t_{ABH}$	ABCLK Delay High		max	ns	From MCLK Rising $256 \times f_S$ $512 \times f_S$ $768 \times f_S$
$t_{ABL}$	ABCLK Delay Low		max	ns	From MCLK Rising $256 \times f_S$ $512 \times f_S$ $768 \times f_S$
$t_{ALS}$	LRCLK Delay		max	ns	From ABCLK Falling
$t_{ABDD}$	ASDATA Delay		max	ns	From ABCLK Falling
$t_{ALRDD}$	ASDATA Delay		max	ns	From ALRCLK Changing (Left-Justified)
TDM PACKED AUX, MASTER MODE					
$t_{ABH}$	ABCLK Delay High		max	ns	From MCLK Rising $256 \times f_S$ $512 \times f_S$ $768 \times f_S$
$t_{ABL}$	ABCLK Delay Low		max	ns	From MCLK Rising $256 \times f_S$ $512 \times f_S$ $768 \times f_S$
$t_{XBH}$	AUXBCLK Delay High		max	ns	From MCLK Rising $256 \times f_S$ $512 \times f_S$ $768 \times f_S$
$t_{XBL}$	AUXBCLK Delay Low		max	ns	From MCLK Rising $256 \times f_S$ $512 \times f_S$ $768 \times f_S$
$t_{ALS}$	LRCLK Delay		max	ns	From ABCLK Falling
$t_{XLS}$	AUXLRCLK Delay		max	ns	From ABCLK Falling
$t_{ABDD}$	ASDATA Delay		max	ns	From ABCLK Falling
$t_{ALRDD}$	ASDATA Delay		max	ns	From ALRCLK Changing (Left-Justified)
$t_{DDS}$	AAUXDATA Setup	min		ns	To AUXBCLK Rising
$t_{DDH}$	AAUXDATA Hold	min		ns	From AUXBCLK Rising
$t_{DDS}$	DSDATA Setup	min		ns	To DBCLK Rising
$t_{DDH}$	DSDATA Hold	min		ns	From DBCLK Rising
$t_{DXDD}$	DAUXDATA Delay		max	ns	From AUXBCLK Falling
$t_{DXDD}$	DAUXDATA Delay		max	ns	From AUXLRCLK Changing (Left-Justified)

**TIMING (continued)**

Parameter		Min	Max	Unit	Comments
TDM, PACKED AUX, SLAVE MODE					
t <sub>ABH</sub>	ABCLK High	min		ns	
t <sub>ABL</sub>	ABCLK Low	min		ns	
t <sub>ABP</sub>	ABCLK Period	min		ns	
f <sub>AB</sub>	ABCLK Freq		max	ns	
t <sub>ALS</sub>	LRCLK Setup	min		ns	To ABCLK Rising
t <sub>ALH</sub>	LRCLK Hold	min		ns	To ABCLK Rising
t <sub>ABDD</sub>	ASDATA Delay	max		ns	From ABCLK Falling
t <sub>ALRDD</sub>	ASDATA Delay		max	ns	From ALRCLK Changing (Left-Justified)
t <sub>AXDS</sub>	AAUXDATA Setup	min		ns	To AUXBCLK Rising
t <sub>AXDH</sub>	AAUXDATA Hold	min		ns	From AUXBCLK Rising
t <sub>DDS</sub>	DSDATA Setup	min		ns	To DBCLK Rising
t <sub>DDH</sub>	DSDATA Hold	min		ns	From DBCLK Rising
t <sub>DXDD</sub>	DAUXDATA Delay	max		ns	From AUXBCLK Falling
t <sub>DXDD</sub>	DAUXDATA Delay	max		ns	From AUXLRCLK Changing (Left-Justified)

**POWER SUPPLIES**

Parameter	Min	Typ	Max	Unit
Supplies				
Voltage, Analog and Digital	4.5	5	5.5	V
Analog Current		108		mA
Analog Current, Power-Down		47		mA
Digital Current		78		mA
Digital Current, Power-Down		1.5		mA
Dissipation				
Operation, Both Supplies		930		mW
Operation, Analog Supply		540		mW
Operation, Digital Supply		390		mW
Power-Down, Both Supplies		243		mW
Power Supply Rejection Ratio				
1 kHz 300 mV p-p Signal at Analog Supply Pins		-60		dB
20 kHz 300 mV p-p Signal at Analog Supply Pins		-50		dB

**TEMPERATURE RANGE**

Parameter	Min	Typ	Max	Unit
Specifications Guaranteed		25		°C
Functionality Guaranteed	-40		+85	°C
Storage	-65		+150	°C

Specifications subject to change without notice.

# PRELIMINARY TECHNICAL DATA

## AD1836

### ABSOLUTE MAXIMUM RATINGS\*

Parameter	Min	Max	Unit
Power Supplies			
Analog (AVDD)	-0.3	6.0	V
Digital (DVDD)	-0.3	6.0	V
Input Current (Except Supply Pins)		±20	mA
Analog Input Voltage (Signal Pins)	-0.3	AVDD + 0.3	V
Digital Input Voltage (Signal Pins)	-0.3	DVDD + 0.3	V
Ambient Temperature (Operating)	-40	+85	°C
ESD Tolerance (Human Body Model, Method 3015.2, MIL-STD-883B)	1		kV

\*Stresses greater than those listed under Absolute Maximum Ratings may cause permanent damage to the device. This is a stress rating only; functional operation of the device at these or any other conditions above those indicated in the operational section of this specification is not implied. Exposure to absolute maximum rating conditions for extended periods may affect device reliability.

### PIN CONFIGURATION 52-Lead MQFP

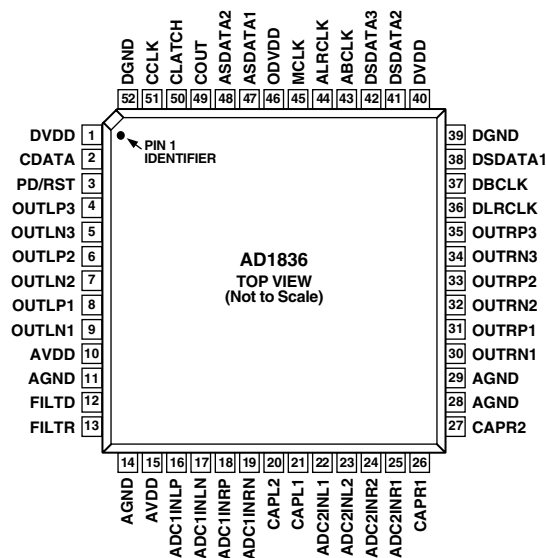

### ORDERING INFORMATION

Model	Temperature Range	Package Description	Package Option
AD1836AS	-40 to +85°C	52-Lead MQFP	S-52

### CAUTION

ESD (electrostatic discharge) sensitive device. Electrostatic charges as high as 4000 V readily accumulate on the human body and test equipment and can discharge without detection. Although the AD1836 features proprietary ESD protection circuitry, permanent damage may occur on devices subjected to high-energy electrostatic discharges. Therefore, proper ESD precautions are recommended to avoid performance degradation or loss of functionality.



## PIN FUNCTION DESCRIPTIONS

PIN No.	Mnemonic	In/Out	Description
1, 40	DVDD	I	Digital Power Supply. Connect to digital 5 V supply.
2	CDATA	I	Serial Control Input
3	PD/RST	I	Power-Down Reset
4	OUTLP3	O	DAC 3 (Left) Positive Output
5	OUTLN3	O	DAC 3 (Left) Negative Output
6	OUTLP2	O	DAC 2 (Left) Positive Output
7	OUTLN2	O	DAC 2 (Left) Negative Output
8	OUTLP1	O	DAC 1 (Left) Positive Output
9	OUTLN1	O	DAC 1 (Left) Negative Output
10, 15	AVDD	I	Analog Power Supply. Connect to analog 5 V.
11, 14, 28, 29	AGND	I	Analog Ground
12	FILTD	I	Filter Capacitor Connection. Recommend 10 $\mu$ F//100 nF.
13	FILTR	I	Voltage Reference Filter Capacitor Connection. Recommend 10 $\mu$ F//100 nF.
16	ADC1INLP	I	ADC1 Left Positive Input
17	ADC1INLN	I	ADC1 Left Negative Input
18	ADC1INRP	I	ADC1 Right Positive Input
19	ADC1INRN	I	ADC1 Right Negative Input
20	ADC2INL+/CAPL2	I	ADC2 Left Positive Input (Direct Mode)/ADC2 Left Decoupling Cap (MUX/PGA and PGA Differential Mode)
21	ADC2INL-/CAPL1	I	ADC2 Left Negative Input (Direct Mode)/ADC2 Left Decoupling Cap (MUX/PGA and PGA Differential Mode)
22	ADC2INL1	I	ADC2 Left Input 2 (MUX/PGA Mode)/Left Positive Input (PGA Differential Mode)
23	ADC2INL2	I	ADC2 Left Input 1 (MUX/PGA Mode)/Left Negative Input (PGA Differential Mode)
24	ADC2INR2	I	ADC2 Right Input 1 (MUX/PGA Mode)/Right Negative Input (PGA Differential Mode)
25	ADC2INR1	I	ADC2 Right Input 2 (MUX/PGA Mode)/Right Positive Input (PGA Differential Mode)
26	ADC2INR-/CAPR1	I	ADC2 Right Negative Input (Direct Mode)/ADC2 Right Decoupling Cap (MUX/PGA and PGA Differential Mode)
27	ADC2INR+/CAPR2	I	ADC2 Right Positive Input (Direct Mode)/ADC2 Right Decoupling Cap (MUX/PGA and PGA Differential Mode)
30	OUTRN1	O	DAC 1 (Right) Negative Output
31	OUTRP1	O	DAC 1 (Right) Positive Output
32	OUTRN2	O	DAC 2 (Right) Negative Output
33	OUTRP2	O	DAC 2 (Right) Positive Output
34	OUTRN3	O	DAC 3 (Right) Negative Output
35	OUTRP3	O	DAC 3 (Right) Positive Output
36	DLRCLK	I/O	LR Clock for DACs
37	DBCLK	I/O	Bit Clock for DACs
38	DSDATA1	I	DAC Input #1 (Input to DAC1 and DAC2)
39, 52	DGND	I	Digital Ground
41	DSDATA2	I	DAC Input #2 (Input to DAC3 and DAC4)
42	DSDATA3	I	DAC Input #3 (Input to DAC5 and DAC6)
43	ABCLK	O	Bit Clock for ADCs
44	ALRCLK	O	LR Clock for ADCs
45	MCLK	I	Master Clock Input
46	ODVDD	I	Digital Output Driver Power Supply
47	ASDATA1	O	ADC Serial Data Output #1
48	ASDATA2	O	ADC Serial Data Output #2
49	COUT	O	Output for Control Data
50	CLATCH	I	Latch Input for Control Data
51	CCLK	I	Control Clock Input for Control Data
52	DGND	I	Digital Ground

## AD1836

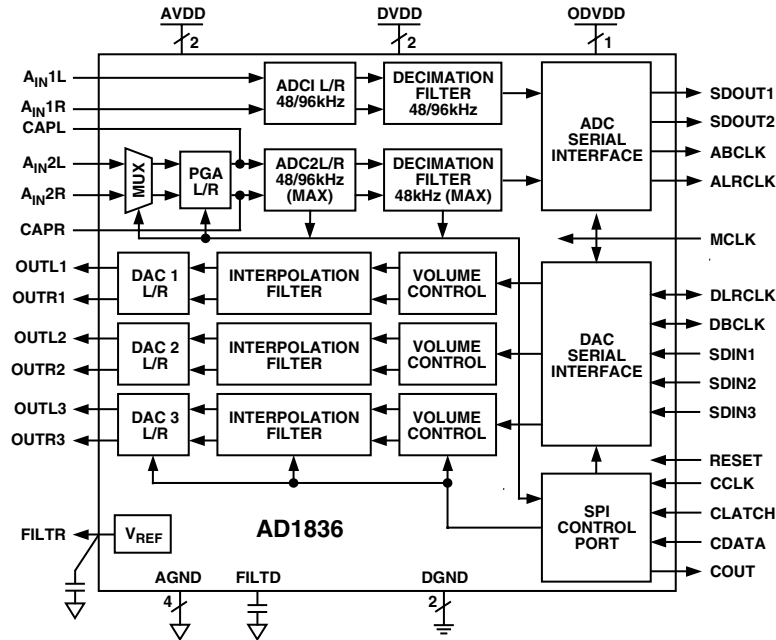

Figure 1.

## FUNCTIONAL OVERVIEW

## ADCs

There are four ADC channels in the AD1836, configured as two independent stereo pairs. One stereo pair is the primary ADC and has fully differential inputs. The second pair can be programmed to operate in one of three possible input modes (programmed via SPI ADC Control Register 3). The ADC section may also operate at a sample rate of 96 kHz, with only the two primary channels active. The ADCs include an on-board digital decimation filter with 120 dB stopband attenuation and linear phase response, operating at an oversampling ratio of 128 (for 4-channel 48 kHz operation) or 64 (for two-channel 96 kHz operation).

The primary ADC pair should be driven from a differential signal source for best performance. The input pins of the primary ADC connect directly to internal switched capacitors. To isolate the external driving op amp from the “glitches” caused by the internal switched-capacitors, each input pin should be isolated by using a series-connected external 100  $\Omega$  resistor together with a 1 nF capacitor connected from each input to ground. This capacitor must be of high quality; for example, ceramic NPO or polypropylene film.

The secondary input pair can be operated in one of the following three modes:

1. Direct differential inputs (driven the same as the primary ADC inputs described above).
2. PGA mode with differential inputs (Figure 13). In this mode, the PGA amplifier can be programmed using the SPI port to give an input gain of 0 to 12 dB in 3 dB steps. External capacitors are used after the PGA to supply filtering for the switched-capacitor inputs.
3. Single-ended MUX/PGA mode. In this mode, two single-ended stereo inputs are provided that can be selected using the SPI port. Input gain can be programmed from 0 dB to 12 dB in steps of 3 dB. External capacitors are used to supply filtering for the switched-capacitor inputs.

ADC peak level information for each ADC may be read from the SPI port through Registers 12 through 15. The data is supplied as a 10-bit word with a maximum range of 0 dB to -60 dB and a resolution of 1 dB. The registers will hold peak information until read; after reading, the registers are reset so that new peak information can be acquired. Refer to the register description for details of the format.

The voltage at the  $V_{REF}$  pin, FILTR ( $\sim 2.25$  V) can be used to bias external op amps used to buffer the input signals. This source can be connected directly to op amp inputs but should be buffered if it is required to drive resistive networks.

## DACs

The AD1836 has six DAC channels arranged as three independent stereo pairs, with six fully differential analog outputs for improved noise and distortion performance. Each channel has its own independently programmable attenuator, adjustable in 1024 linear steps. Digital inputs are supplied through three serial data input pins (one for each stereo pair) and a common frame (DLRCLK) and bit (DBLCK) clock. Alternatively, one of the “packed data” modes may be used to access all six channels on a single TDM data pin.

Each set of differential output pins sits at a dc level of  $V_{REF}$ , and swings  $\pm 1.4$  V for a 0 dB digital input signal. A single op amp third-order external low-pass filter is recommended to remove high-frequency noise present on the output pins, as well as to provide differential-to-single-ended conversion. A recommended circuit is shown in Figure 2. Note that the use of op amps with low slew rate or low bandwidth may cause high-frequency noise and tones to fold down into the audio band; care should be exercised in selecting these components.

The FILTR pin should be connected to an external grounded capacitor. This pin is used to reduce the noise of the internal DAC bias circuitry, thereby reducing the DAC output noise. In some cases this capacitor may be eliminated with little effect on performance. The voltage at the  $V_{REF}$  pin, FILTR ( $\sim 2.25$  V) can be used to bias external op amps used to buffer the output signals.



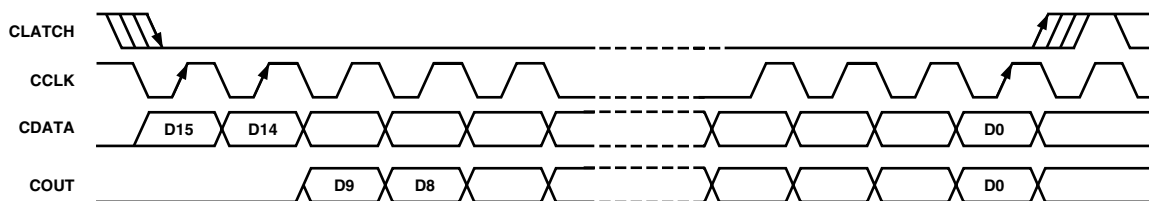

Figure 2. Format of SPI Signal

### Clock Signals

The master clock frequency can be selected for 256, 512, or 768 times the sample rate. The default at power-up is  $256 f_s$ . For operation at 96 kHz, the master clock frequency should stay at the same absolute frequency. For example, if the AD1836 is programmed in  $256 \times f_s$  mode and operated in the normal 48 kHz 4-channel mode, the frequency of the master-clock would be  $256 \times 48 \text{ kHz} = 12.288 \text{ MHz}$ . If the AD1836 is then switched to 96 kHz operation (via writing to the SPI port), the frequency of the master-clock should remain at 12.288 MHz (which is now  $128 \times f_s$ ).

The internal clock used in the AD1836 is  $512 \times f_s$  (48 kHz mode) or  $512 \times f_s$  (96 kHz mode). Clock doublers are used to generate this internal master-clock from the external clocks. Since clock-doublers have a limited range of operation, it is recommended that the part be operated in  $512 \times f_s$  mode if the desired sampling rates are not at all close to the common audio sampling rates for which the part was designed.

To maintain the highest performance possible, it is recommended that the clock jitter of the master clock signal be limited to less than 300 ps rms, measured using the edge-to-edge technique. Even at these levels, extra noise or tones may appear in the DAC outputs if the jitter spectrum contains large spectral peaks. It is highly recommended that the master clock be generated by an independent crystal oscillator. In addition, it is especially important that the clock signal should not be passed through an FPGA or other large digital chip before being applied to the AD1836. In most cases this will induce clock jitter due to the fact that the clock signal is sharing common power and ground connections with other unrelated digital output signals.

The six DAC channels use a common serial bit clock to clock in the serial data and a common left-right framing clock. The four ADC channels output a common serial bit clock and a left-right framing clock. The clock signals are all synchronous with the sample rate.

### RESET and Power-Down

RESET will power down the chip and set the control registers to their default settings. After reset is deasserted, an initialization routine will run inside the AD1836 to clear all memories to zero. This initialization lasts for approximately 20 LRCLK intervals. During this time it is recommended that no SPI writes occur.

### Serial Control Port

The AD1836 has an SPI-compatible control port to permit programming the internal control registers for the ADCs and

DACs and for reading the ADC signal level from the internal peak detectors. The DAC output levels may be independently programmed by means of an internal digital attenuator adjustable in 1024 linear steps.

The SPI control port is a 4-wire serial control port. The format is similar to the Motorola SPI format except the input data word is 16-bits wide. Max serial bit clock frequency is 8 MHz and may be completely asynchronous to the sample rate of the ADCs and DACs. The following figure shows the format of the SPI signal. Note that the CCLK should be run continuously and not stop between SPI transactions.

### Power Supply and Voltage Reference

The AD1836 is designed for 5 V supplies. Separate power supply pins are provided for the analog and digital sections. These pins should be bypassed with 100 nF ceramic chip capacitors, as close to the pins as possible, to minimize noise pickup. A bulk aluminum electrolytic capacitor of at least 22  $\mu\text{F}$  should also be provided on the same PC board as the codec. For critical applications, improved performance will be obtained with separate supplies for the analog and digital sections. If this is not possible, it is recommended that the analog and digital supplies be isolated by means of two ferrite beads in series with the bypass capacitor of each supply. It is important that the analog supply be as clean as possible.

The internal voltage reference is brought out on Pin 13 (FILTR) and should be bypassed as close as possible to the chip, with a parallel combination of 10  $\mu\text{F}$  and 100 nF. The reference voltage may be used to bias external op amps to the common-mode voltage of the analog input and output signal pins. The current drawn from the  $V_{\text{REF}}$  pin should be limited to less than 50  $\mu\text{A}$ .

### Serial Data Ports—Data Format

The ADC serial data output mode defaults to the popular I<sup>2</sup>S format, where the data is delayed by 1 BCLK interval from the edge of the LRCLK. By changing Bits 8 and 9 in ADC Control Register 2, the serial mode can be changed to Right-Justified (RJ), Left-Justified DSP (DSP) or Left-Justified (LJ). In the RJ mode, it is necessary to set Bits 6 and 7 to define the width of the data word.

The DAC serial data input mode defaults to I<sup>2</sup>S. By changing Bits 5, 6, and 7 in DAC Control Register 1, the mode can be changed to RJ, DSP, LJ, Packed Mode 1 or Packed Mode 2.

# AD1836

The word width defaults to 24 bits but can be changed by reprogramming Bits 3 and 4 in DAC Control Register 1. The packed modes accept six channels of data at the DSDATA1 input pin which is independently routed to each of the six internal DACs.

A special “auxiliary mode” is provided to allow two external stereo ADCs and one external stereo DAC to be interfaced to the AD1836 to provide 8-in/8-out operation. In addition, this mode supports glueless interface to a single SHARC DSP serial port, allowing a SHARC DSP to access all eight channels of analog I/O. In this special mode, many pins are redefined; see Table I for a list of redefined pins. Two versions of this mode are available. In the “master” mode, the AD1836 provides the

LRCLK and BCLK signals, and the external ADCs operate in slave mode. In the “slave” mode, the external ADCs provide the LRCLK and BCLK signals (which must be divided down properly from the external master clock), and the AD1836 will sync to these external clocks. See Figures 8 through 10 for details of this mode. Figure 11 shows the internal signal-flow diagram of the auxiliary mode.

The following figures show the serial mode formats.

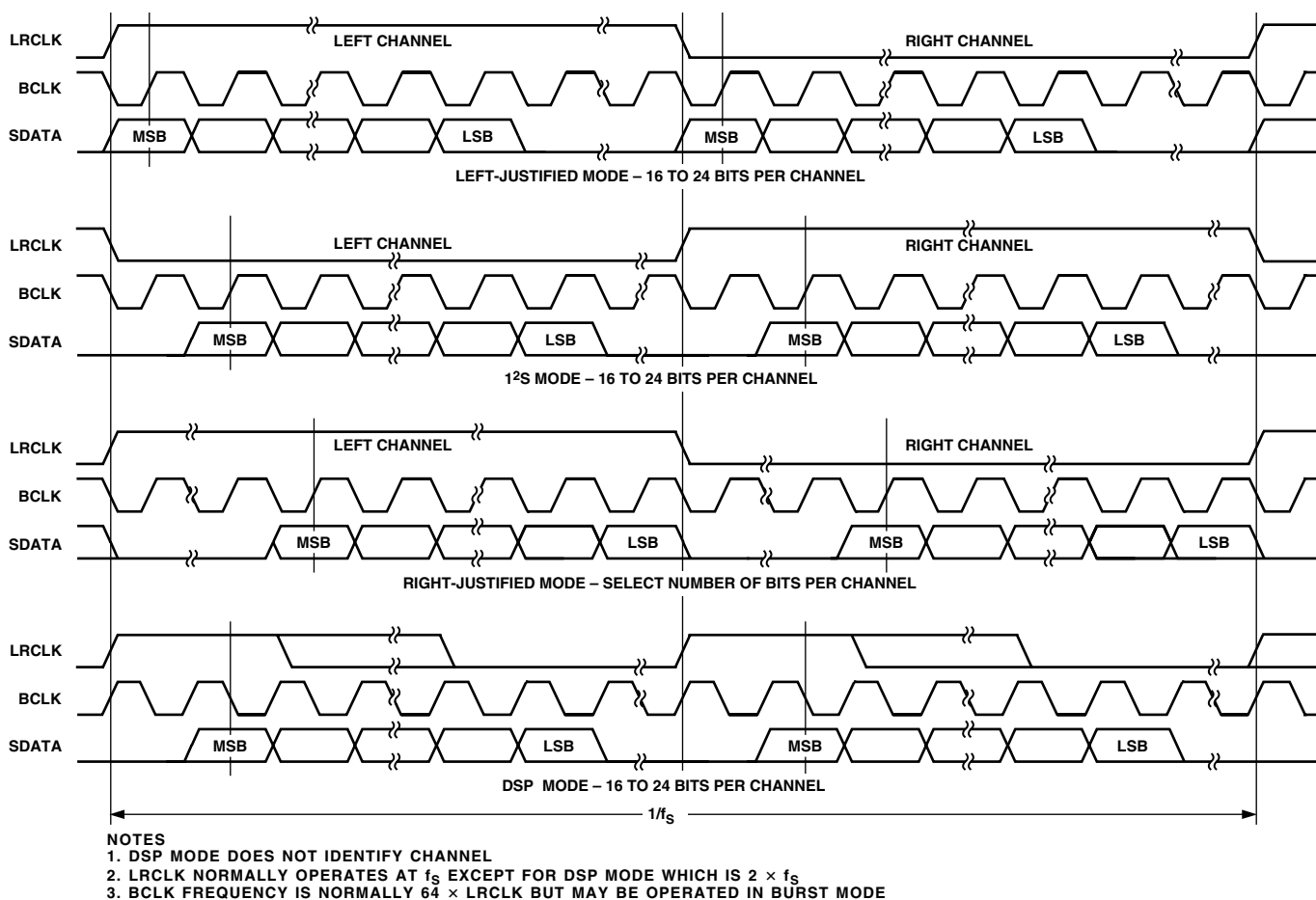

Figure 3. Stereo Serial Modes

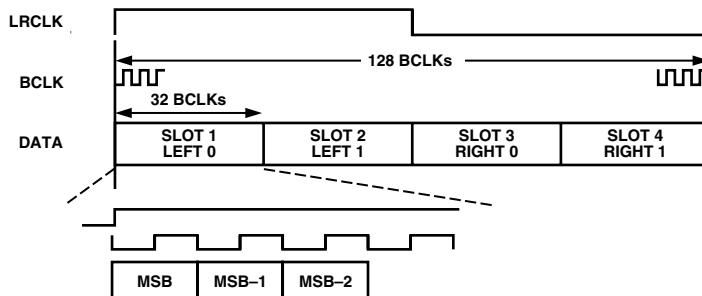

Figure 4. ADC Packed Mode 128

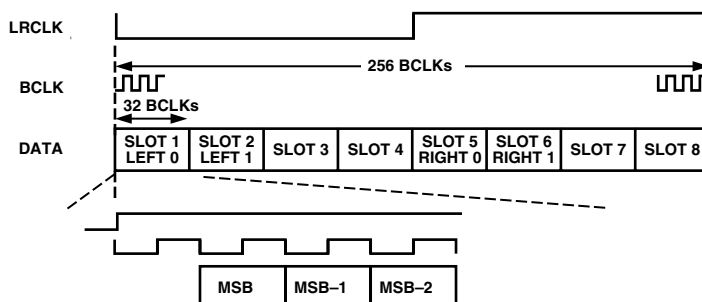

Figure 5. ADC Packed Mode 256

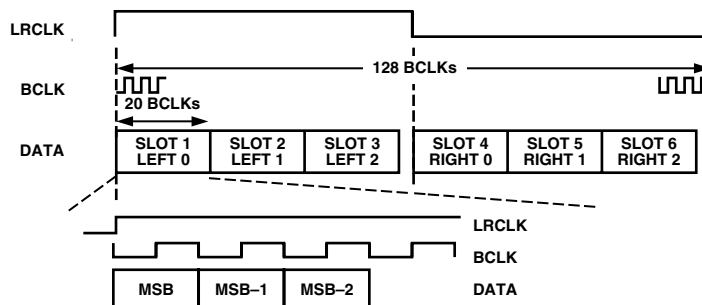

Figure 6. DAC Packed Mode 128

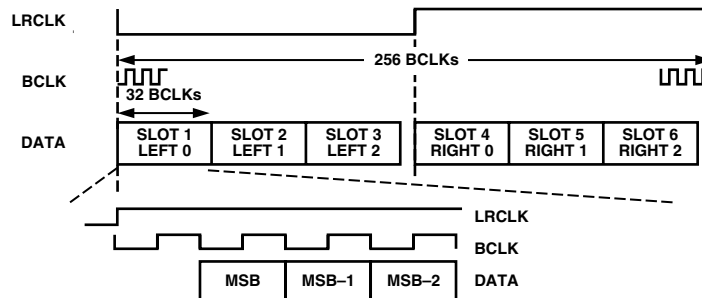
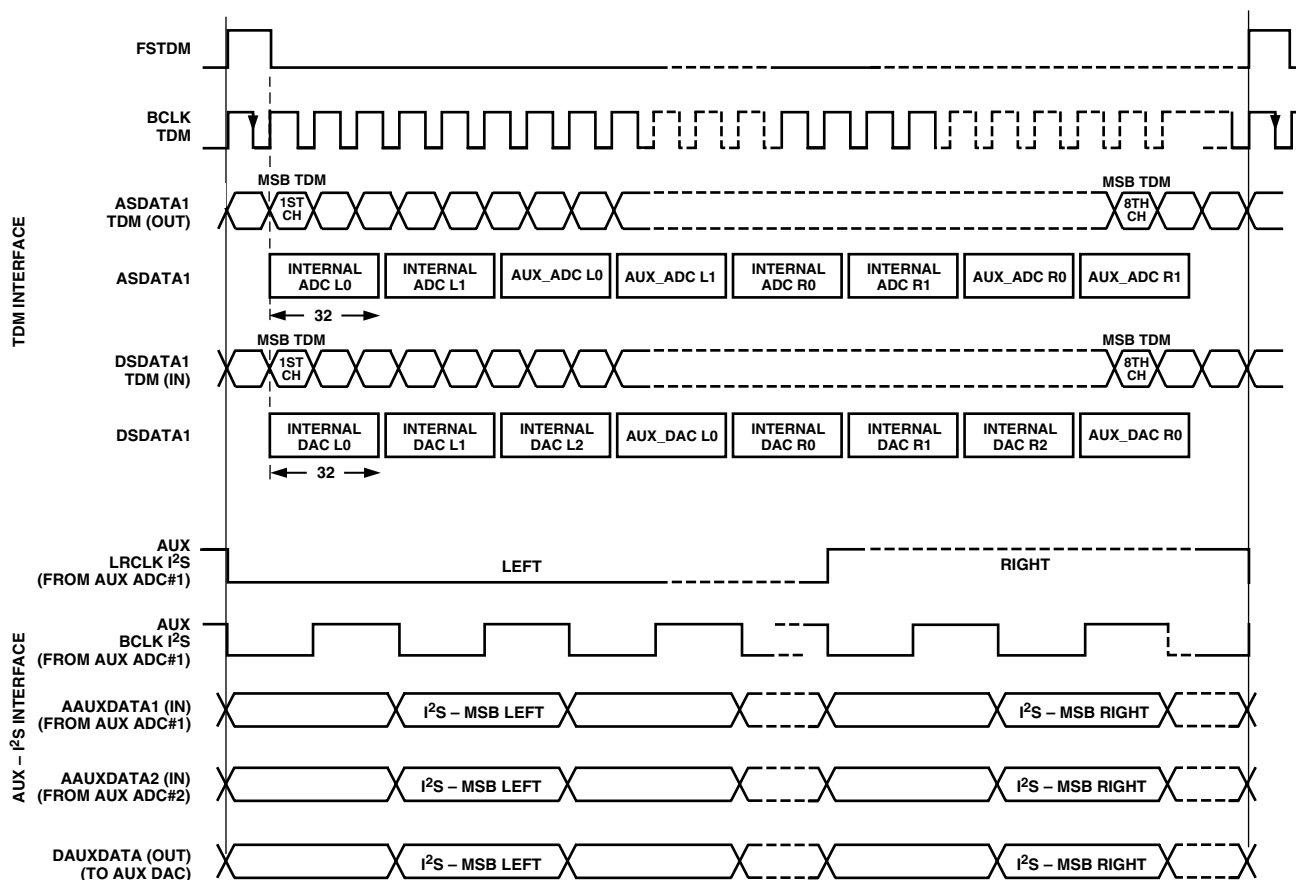

Figure 7. DAC Packed Mode 256

AD1836



NOTE:  
AUX BCLK FREQUENCY IS  $64 \times \text{FRAME-RATE}$ ; TDM BCLK FREQUENCY IS  $256 \times \text{FRAME-RATE}$ .

Figure 8. AUX-Mode Timing

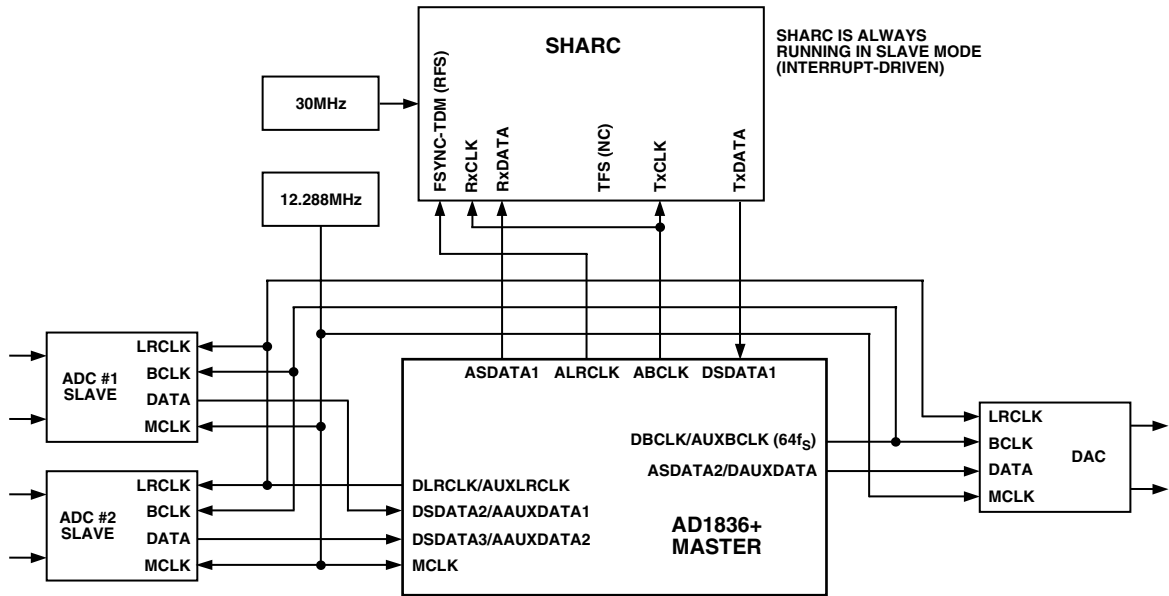

Figure 9. AUX-Mode Connection to SHARC (Master Mode)

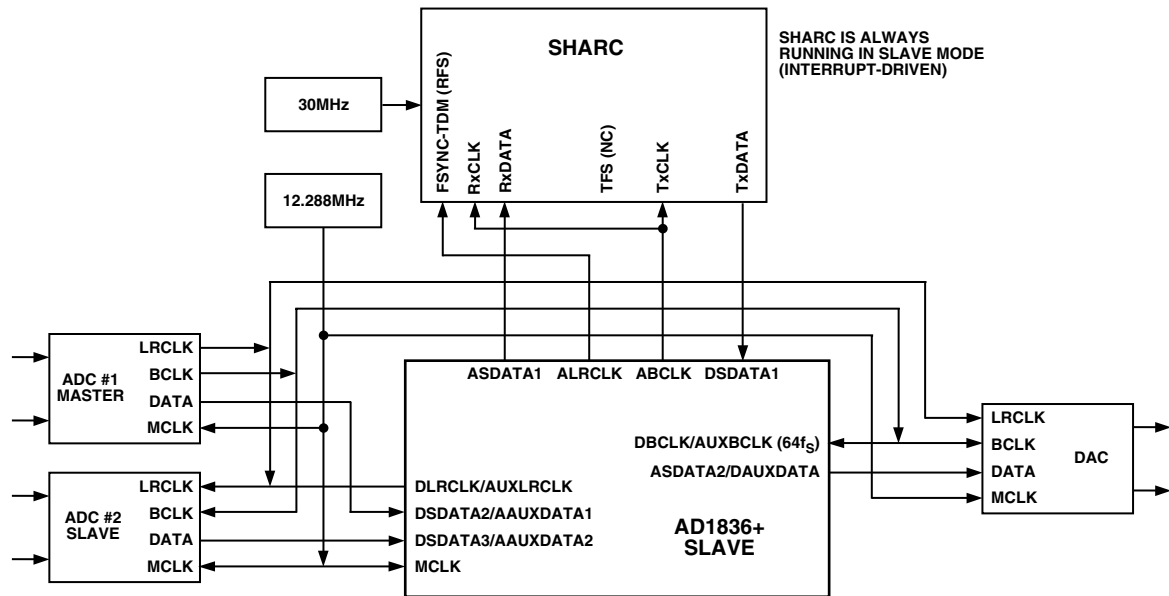

Figure 10. AUX-Mode Connection to SHARC (Slave Mode)

AD1836

Table I. Pin Function Changes in AUX-Mode

Pin Name (I <sup>2</sup> S/AUX-Mode)	I <sup>2</sup> S-Mode	AUX-Mode
ASDATA1(O)	I <sup>2</sup> S Data Out, Internal ADC1	TDM Data Out, to SHARC
ASDATA2(O)/DAUXDATA(O)	I <sup>2</sup> S Data Out, Internal ADC2	AUX-I <sup>2</sup> S-Data Out (to Ext. DAC)
DSDATA1(I)	I <sup>2</sup> S Data In, Internal DAC1	TDM Data In, from SHARC
DSDATA2(I)/AAUXDATA(I)	I <sup>2</sup> S Data In, Internal DAC2	AUX-I <sup>2</sup> S-Data in 1 (from Ext. ADC)
DSDATA3(I)/AAUXDATA2(I)	I <sup>2</sup> S Data in Internal DAC3	AUX-I <sup>2</sup> S-Data in 2 (from Ext. ADC)
ALRCLK(O)	LRCLK for Internal ADC1, 2	TDM Frame Sync Out, to SHARC
ABCLK(O)	BCLK for Internal ADC1, 2	TDM BCLK Out, to SHARC
DLRCLK(I)/AUXLRCLK(I/O)	LRCLK In/Out Internal DACs	AUX LRCLK IN/OUT, Driven by Ext. IRCLK from ADC (in Slave Mode). In Master Mode, Driven by Internal MCLK/512.
DBCLK(I)/AUXBCLK(I/O)	BCLK In/Out Internal DACs	AUX BCLK IN/OUT, Drive by Ext. BCLK from ADC (in Slave Mode). In Master Mode, Driven by Internal MCLK/8.

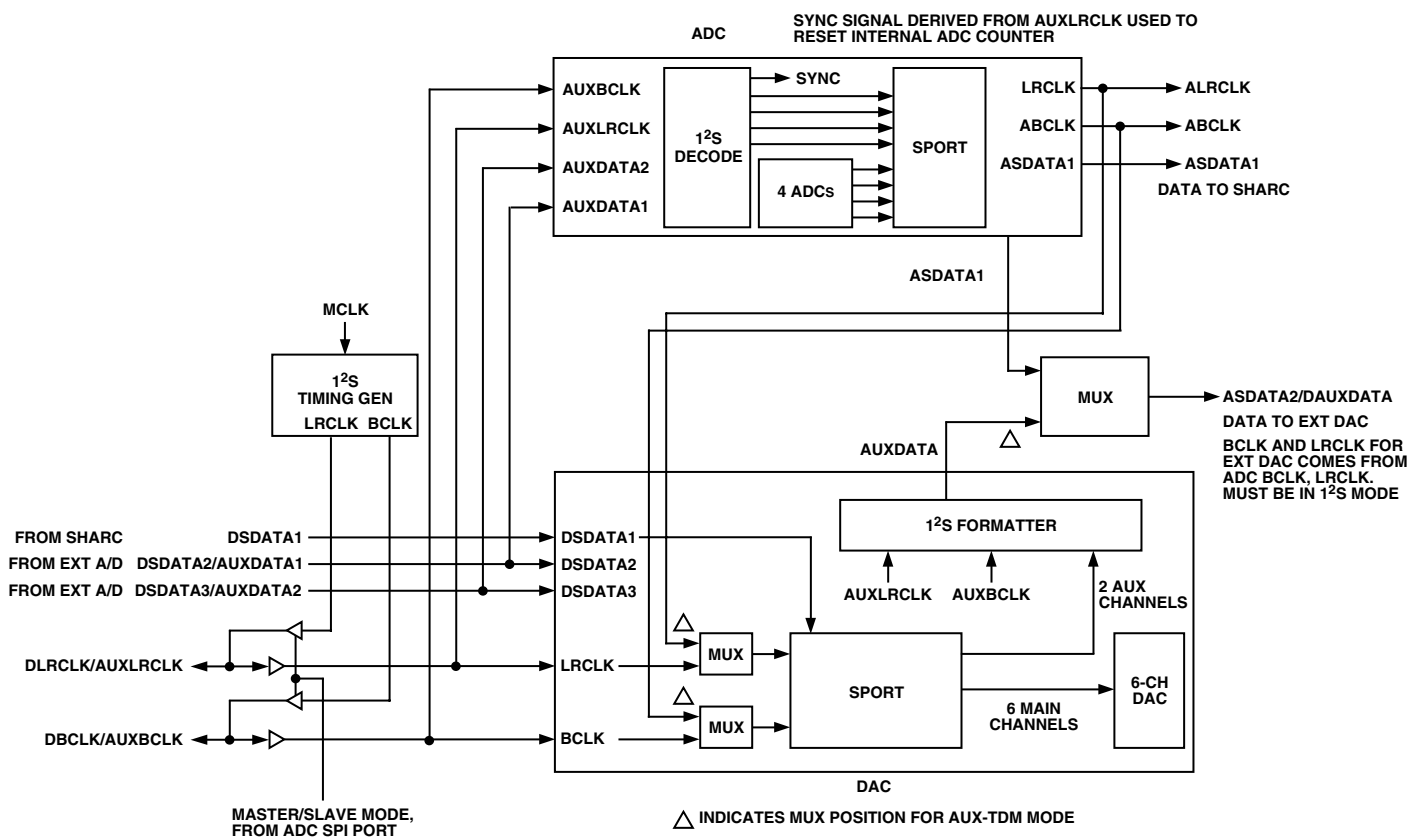

Figure 11. Extended TDM Mode Internal Flow Diagram

SPI CONTROL REGISTERS

Note: All control registers default to zero at power-up.

Serial SPI Word Format

Register Address	Read/Write	Reserved	Data Field
15..12	11	10	9..0
4 Bits	1 = Read 0 = Write	0	10 Bits

Register Addresses and Functions

Register Address				RD/WR	RSVD	Function
Bit 15	Bit 14	Bit 13	Bit 12	Bit 11	Bit 10	(Bits 9:0)
0	0	0	0	0	0	DAC Control 1
0	0	0	1	0	0	DAC Control 2
0	0	1	0	0	0	DAC Volume 0
0	0	1	1	0	0	DAC Volume 1
0	1	0	0	0	0	DAC Volume 2
0	1	0	1	0	0	DAC Volume 3
0	1	1	0	0	0	DAC Volume 4
0	1	1	1	0	0	DAC Volume 5
1	0	0	0	0	0	ADC 0 – Peak Level (Read Only)
1	0	0	1	0	0	ADC 1 – Peak Level (Read Only)
1	0	1	0	0	0	ADC 2 – Peak Level (Read Only)
1	0	1	1	0	0	ADC 3 – Peak Level (Read Only)
1	1	0	0	0	0	ADC Control 1
1	1	0	1	0	0	ADC Control 2
1	1	1	0	0	0	ADC Control 3
1	1	1	1	0	0	Reserved

DAC Control Register 1

Address	RD/WR	RSVD	Function					
			De-Emphasis	Serial Mode	Data Word Width	Power-Down Reset	Interpolator Mode	Reserved
15, 14, 13, 12	11	10	9, 8	7, 6, 5	4, 3	2	1	0
0000	0	0	00 = None 01 = 44.1 kHz 10 = 32.0 kHz 11 = 48.0 kHz	000 = I <sup>2</sup> S 001 = RJ 010 = DSP 011 = LJ 100 = Pack Mode 256 101 = Pack Mode 128 110 = Reserved 111 = Reserved	00 = 24-Bits 01 = 20 Bits 10 = 16 Bits 11 = Reserved	0 = Normal 1 = PWRDWN	0 = 8 × (48 kHz) 1 = 4 × (96 kHz)	0

NOTES

Packed Mode: Four channels are “packed” into DSDATA1 serial input.  
 Packed Mode 128: Refer Figure 6.  
 Packed Mode 256: Refer to Figure 7.

# PRELIMINARY TECHNICAL DATA

## AD1836

### DAC Control Register 2

Address	RD/WR	Reserved	Function					
			Mute DAC					
15, 14, 13, 12	11	10, 9, 8, 7, 6	5	4	3	2	1	0
0001	0	00000	0 = On 1 = Mute5	0 = On 1 = Mute4	0 = On 1 = Mute3	0 = On 1 = Mute2	0 = On 1 = Mute1	0 = On 1 = Mute0

### DAC Volume Registers

Address	RD/WR	Reserved	Function
			Volume
15, 14, 13, 12	11	10	9:0
0010: DAC 0 0011: DAC 1 0100: DAC 2 0101: DAC 3 0110: DAC 4 0111: DAC 5	0	0	0 to 1023 in 1024 Linear Steps

### ADC Control Register 1

Address	RD/WR	RSVD	Function				
			Filter	Power-Down	Sample Rate	Left Gain	Right Gain
15, 14, 13, 12	11	9, 10	8	7	6	5, 4, 3	2, 1, 0
1100	0	00	0 = DC 1 = High-Pass	0 = Normal 1 = PWRDWN	0 = 48 kHz 1 = 96 kHz	000 = 0 dB 001 = 3 dB 010 = 6 dB 011 = 9 dB 100 = 12 dB 101 = Rsrvd 110 = Rsrvd 111 = Rsrvd	000 = 0 dB 001 = 3 dB 010 = 6 dB 011 = 9 dB 100 = 12 dB 101 = Rsrvd 110 = Rsrvd 111 = Rsrvd

NOTE  
High-Pass Filter: 3 Hz High-Pass Filter.

### ADC Control Register 2

Address	RD/WR	RSVD	Master/Slave AUX Mode	SOUT Mode	Word Width	ADC Mute			
						Right	Left	Right	Left
15, 14, 13, 12	11	10	9	8, 7, 6	5, 4	3	2	1	0
1101	0	0	0 = Slave 1 = Master	000 = I <sup>2</sup> S 001 = RJ 010 = DSP 011 = LJ 100 Packed 256 101 Packed 128 110 Packed AUX*	00 = 24 Bits 01 = 20 Bits 10 = 16 Bits 11 = Invalid	0 = On 1 = Mute3	0 = On 1 = Mute2	W/Gain 0 = On 1 = Mute1	W/Gain 0 = On 1 = Mute0

NOTES  
\*Note that Packed AUX mode affects the entire chip, including the DAC serial mode.  
Packed Mode: Four channels are packed into ASDATA1 serial output.  
Packed Mode 128: Refer Figure 4.  
Packed Mode 256: Refer to Figure 5.  
Packed AUX: Refer to Figures 8 to 11.



ADC Control Register 3

Address	RD/WR	Reserved	Clock Mode	Function					
				Left Diff. I/P Select	Right Diff. I/P Select	Left MUX/PGA Enable	Left MUX I/P Select	Right MUX/PGA Enable	Right MUX I/P Select
15, 14, 13, 12	11	10, 9, 8	7, 6	5	4	3	2	1	0
1110	0	000	00 = $256 \times f_S$ 01 = $512 \times f_S$ 10 = $768 \times f_S$	0 = Differential PGA Mode. 1 = PGA/MUX	0 = Differential PGA Mode. 1 = PGA/MUX Mode (Single-Ended Input)	0 = Direct 1 = MUX/PGA Mode (Single-Ended Input)	0 = I/P 0 1 = I/P 1	0 = Direct 1 = MUX/PGA	0 = I/P 0 1 = I/P 1

\*When changing clock doubler bypass mode, other SPI bits that are written during the same SPI transaction may be lost. It is therefore recommended that a separate transaction be used for setting CLKDBL Bypass Mode.

ADC Peak Level Data Registers

Address	RD/WR	RSVD	Peak Level Data (10 Bits)	
			6-Data Bits	4-Fixed Bits
15, 14, 13, 12	11	10	9..4	3..0
1000 = ADC0 1001 = ADC1 1010 = ADC2 1011 = ADC3	1	0	000000 = 0.0 dBFS 000001 = -1.0 dBFS 000010 = -2.0 dBFS 000011 = -3.0 dBFS . . . 111111 = -63 dBFS	0000      The four LSBs are always zero.

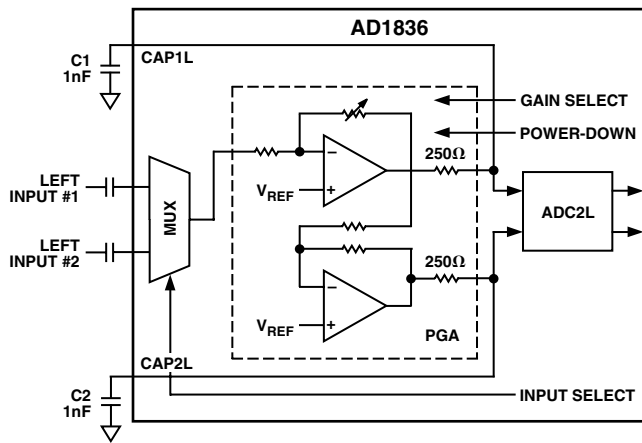

NOTE  
ADC2 SINGLE-ENDED MUX PGA INPUT MODE – LEFT CHANNEL ONLY SHOWN  
CONTROL REGISTER 3 CONTENTS: 6 LSBs: SELECT INPUT #1: 11 1010  
SELECT INPUT #2: 11 1111

Figure 12. Single-Ended MUX/PGA Mode

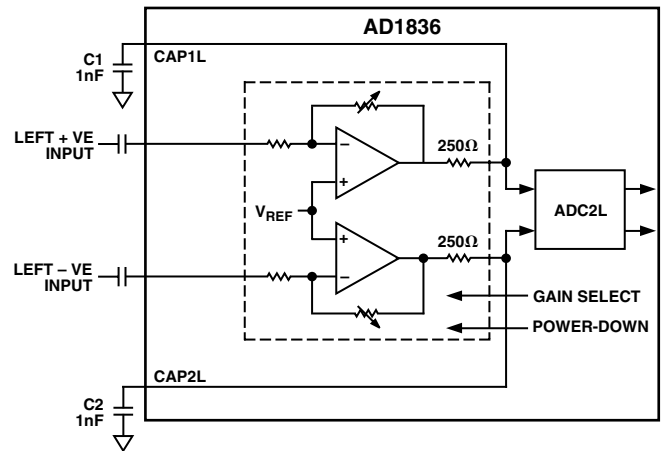

NOTE  
ADC2 DIFFERENTIAL PGA INPUT MODE – LEFT CHANNEL ONLY SHOWN  
CONTROL REGISTER 3 CONTENTS: 6 LSBs: 00 1010

Figure 13. Differential Mode

AD1836

52-Lead MQFP  
(S-52)

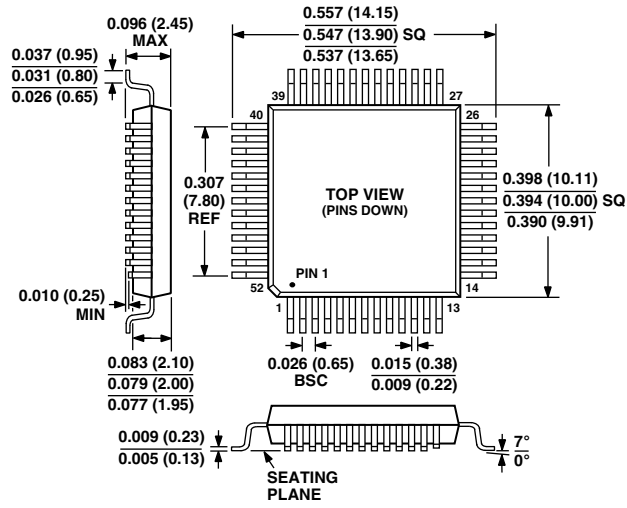

DIMENSIONS PER JEDEC STANDARDS MO-112  
CONTROLLING DIMENSIONS ARE IN MILLIMETERS



Компания «ЭлектроПласт» предлагает заключение долгосрочных отношений при поставках импортных электронных компонентов на взаимовыгодных условиях!

Наши преимущества:

- Оперативные поставки широкого спектра электронных компонентов отечественного и импортного производства напрямую от производителей и с крупнейших мировых складов;
- Поставка более 17-ти миллионов наименований электронных компонентов;
- Поставка сложных, дефицитных, либо снятых с производства позиций;
- Оперативные сроки поставки под заказ (от 5 рабочих дней);
- Экспресс доставка в любую точку России;
- Техническая поддержка проекта, помощь в подборе аналогов, поставка прототипов;
- Система менеджмента качества сертифицирована по Международному стандарту ISO 9001;
- Лицензия ФСБ на осуществление работ с использованием сведений, составляющих государственную тайну;
- Поставка специализированных компонентов (Xilinx, Altera, Analog Devices, Intersil, Interpoint, Microsemi, Aeroflex, Peregrine, Syfer, Eurofarad, Texas Instrument, Miteq, Cobham, E2V, MA-COM, Hittite, Mini-Circuits, General Dynamics и др.);

Помимо этого, одним из направлений компании «ЭлектроПласт» является направление «Источники питания». Мы предлагаем Вам помощь Конструкторского отдела:

- Подбор оптимального решения, техническое обоснование при выборе компонента;
- Подбор аналогов;
- Консультации по применению компонента;
- Поставка образцов и прототипов;
- Техническая поддержка проекта;
- Защита от снятия компонента с производства.



#### Как с нами связаться

**Телефон:** 8 (812) 309 58 32 (многоканальный)

**Факс:** 8 (812) 320-02-42

**Электронная почта:** [org@eplast1.ru](mailto:org@eplast1.ru)

**Адрес:** 198099, г. Санкт-Петербург, ул. Калинина, дом 2, корпус 4, литера А.