

# MAX14661

# Beyond-the-Rails 16:2 Multiplexer

## General Description

The MAX14661 is a serially controlled, dual-channel analog multiplexer allowing any of the 16 pins to be connected to either common pin simultaneously in any combination. The device features Beyond-the-Rails™ capability so that  $\pm 5.5\text{V}$  signals can be passed with any single supply between +1.6V and +5.5V.

The serial control is selectable between I<sup>2</sup>C and SPI. Both modes provide individual control of each independent switch so that any combination of switches can be applied. I<sup>2</sup>C mode provides two address-select pins allowing for addressing up to four devices on a single bus. The SPI mode includes a DOUT pin that can be used to chain multiple devices together with a single select signal.

The IC is available in a 28-pin (4mm x 4mm) TQFN package and is specified over the -40°C to +85°C extended temperature range. The AB\_ and COM\_ pins provide  $\pm 10\text{kV}$  ESD protection (HBM).

## Applications

- System Diagnostics
- Data Acquisition
- I<sup>2</sup>C Signal Switching
- Audio Input Selection

## Features and Benefits

- Beyond-the-Rails Technology Reduces Cost and Complexity
  - Switch  $\pm 5.5\text{V}$  Signals from a +1.6V Single Supply
  - Wide +1.6V to +5.5V Supply Range
  - Low  $5.5\Omega$  R<sub>ON</sub> (typ) Across the Supply Range
- Flexible Multiplexing Enables Design Reuse
  - 16:2 Matrix Switch Multiplexer Connects Any Input Pin To Either Common Pin In Any Combination
  - Each Switch is Independently Controlled via I<sup>2</sup>C or SPI
  - Programmable Shadow Registers Allow Simultaneous Updating
- Low Distortion Switching Improves System Performance
  - Total Harmonic Distortion + Noise 0.005% (typ)
  - R<sub>ON</sub> Flatness  $2.5\text{m}\Omega$  (typ) Across Complete Signal Range
- Integrated Protection for System Reliability
  - $\pm 10\text{kV}$  HBM ESD Protection on all AB\_ and COM\_ Pins, Even When Powered Down

[Ordering Information](#) appears at end of data sheet.

Beyond-the-Rails™ is a trademark Maxim Integrated Products, Inc.

Functional Diagram

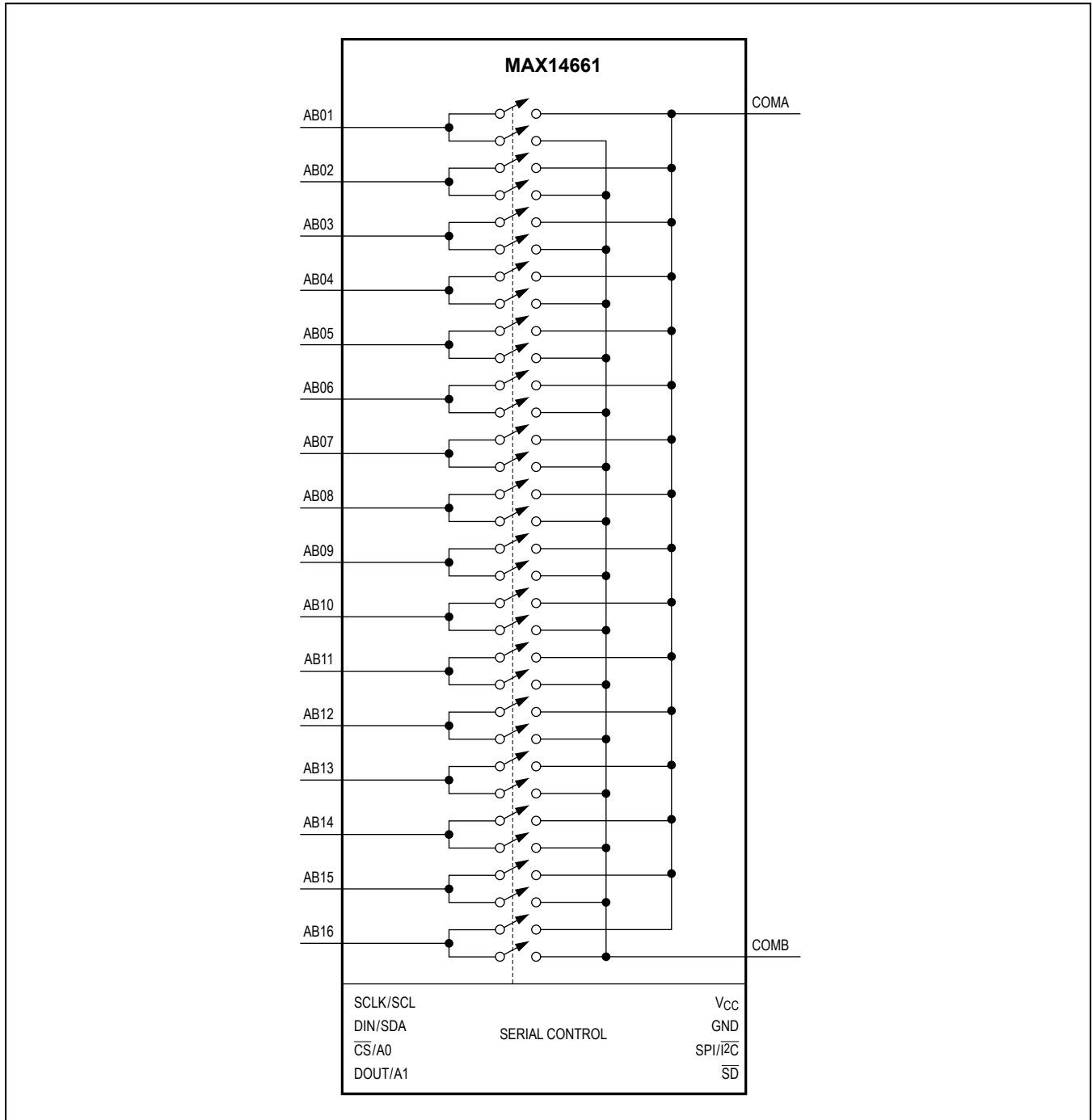

### Absolute Maximum Ratings

(All voltages referenced to GND.)

V<sub>CC</sub>, DIN/SDA, SCLK/SCL, DOUT/A1,  
 $\overline{CS/A0}$ ,  $\overline{SD}$  ..... -0.3V to +6.0V  
 $SPI/\overline{I^2C}$  ..... -0.3V to min (V<sub>CC</sub> to +0.3V, 6V)  
 AB<sub>-</sub>, COM<sub>-</sub> ..... -6.0V to +6.0V  
 Continuous Current (AB<sub>-</sub> or COM<sub>-</sub> to any switch) ..... ±50mA  
 Peak Current (AB<sub>-</sub> or COM<sub>-</sub> to any switch)  
 (pulsed at 1ms, maximum 10% duty cycle) ..... ±100mA

Continuous Power Dissipation

28 TQFN (derate 28.6mW/°C above +70°C) ..... 2285.7mW  
 Operating Temperature Range ..... -40°C to +85°C  
 Maximum Junction Temperature ..... +150°C  
 Storage Temperature Range ..... -65°C to +150°C  
 Lead Temperature (soldering, 10s) ..... +300°C  
 Soldering Temperature (reflow) ..... +260°C

### Package Thermal Characteristics (Note 1)

Junction-to-Case Thermal Resistance (θ<sub>JC</sub>)  
 TQFN ..... 3°C/W

Junction-to-Ambient Thermal Resistance (θ<sub>JA</sub>)  
 TQFN ..... 35°C/W

**Note 1:** Package thermal resistances were obtained using the method described in JEDEC specification JESD51-7, using a four-layer board. For detailed information on package thermal considerations, refer to [www.maximintegrated.com/thermal-tutorial](http://www.maximintegrated.com/thermal-tutorial).

### Electrical Characteristics

(V<sub>CC</sub> = +1.6V to +5.5V, T<sub>A</sub> = -40°C to +85°C, unless otherwise noted. Typical values are at V<sub>CC</sub> = +3.3V, T<sub>A</sub> = +25°C, unless otherwise noted.) (Note 2)

PARAMETER	SYMBOL	CONDITIONS	MIN	TYP	MAX	UNITS
<b>POWER SUPPLY</b>						
Power-Supply Range	V <sub>CC</sub>		1.6		5.5	V
Power-Supply Rejection Ratio	PSRR	R <sub>COM</sub> = 50Ω, V <sub>CC</sub> = +3.3V ±0.1V, f = 10kHz		-84		dB
V <sub>CC</sub> Supply Current	I <sub>CC</sub>	V <sub>CC</sub> = +3.3V, all switches on		675	1500	μA
		V <sub>CC</sub> = +3.3V, two switches on		115	200	
		V <sub>CC</sub> = +3.3V, $\overline{SD}$ = 0			1	
<b>ANALOG SWITCH</b>						
Analog Signal Range	V <sub>AB<sub>-</sub></sub> , V <sub>COM<sub>-</sub></sub>		-5.5		+5.5	V
Analog Signal Amplitude (Notes 3, 4)	V <sub>P-P</sub>	V <sub>CC</sub> > 2.5V f < 500kHz			11	V
		V <sub>CC</sub> < 2.5V, f > 500kHz			6	
		V <sub>CC</sub> = +5V V <sub>CC</sub> = +1.8V			8 12	
On-Resistance Match between Channels	ΔR <sub>ON</sub>	V <sub>CC</sub> = 3.3V, between COM <sub>-</sub> and AB <sub>-</sub>		0.25		Ω
On-Resistance Flatness	R <sub>FLAT</sub>	V <sub>CC</sub> = 3.3V, I <sub>COM<sub>-</sub></sub> = 10mA, V <sub>COM<sub>-</sub></sub> = -5.5V to +5.5V		25		mΩ
AB <sub>-</sub> , COM <sub>-</sub> Off-Leakage Current	I <sub>OFF</sub>	V <sub>CC</sub> = 3.3V, switch open, V <sub>COM<sub>-</sub></sub> = -5.5V, +5.5V V <sub>AB<sub>-</sub></sub> = +5.5V, -5.5V, unconnected (Notes 3, 5)	-50		+50	nA

### Electrical Characteristics (continued)

( $V_{CC} = +1.6V$  to  $+5.5V$ ,  $T_A = -40^{\circ}C$  to  $+85^{\circ}C$ , unless otherwise noted. Typical values are at  $V_{CC} = +3.3V$ ,  $T_A = +25^{\circ}C$ , unless otherwise noted.) (Note 2)

PARAMETER	SYMBOL	CONDITIONS	MIN	TYP	MAX	UNITS
AB_, COM_ On-Leakage Current	$I_{ON}$	$V_{CC} = 3.3V$ , switch closed, $V_{COM\_} = V_{AB\_} = \pm 5.5V$ (Notes 3, 5)	-50		+50	nA
<b>DYNAMIC PERFORMANCE (Notes 6, 7)</b>						
Turn-Off Time	$t_{OFF}$	$V_{COM\_} = 3.0V$ , $R_L = 100\Omega$ , $C_L = 33pF$ , open $\overline{COM\_}$ and $AB\_ together$		5		$\mu s$
Break-Before-Make Time	$t_{BBM}$	$V_{COM\_} = 3.0V$ , $R_L = 100\Omega$ , $C_L = 33pF$ , time for both switching channels are open during transition	0			$\mu s$
Turn-On Time	$t_{ON}$	$V_{COM\_} = 3.0V$ , $R_L = 100\Omega$ , $C_L = 33pF$ ; close $AB\_ and COMA$ or $AB\_ and COMB$ together		13	25	$\mu s$
Enable Time	$t_{EN}$	Time from when $\overline{SD}$ pin goes high to when the device is ready to listen for $I^2C/SPI$ communications			300	$\mu s$
Bandwidth -3dB	BW	$R_S = R_L = 50\Omega$ (Notes 7, 8), $V_{COM\_} =$ $0.6V_{P-P}$		60		MHz
Total Harmonic Distortion Plus Noise	THD + N	$f = 20Hz$ to $20kHz$ , $V_{COM\_} = 0.5V_{P-P}$ , $R_S = R_L = 50\Omega$ , DC bias = 0		0.005		%
Off-Isolation	$V_{ISO}$	$R_S = R_L = 50\Omega$ , $V_{COM\_} = 0.6V_{P-P}$ , $f = 1MHz$ (Note 8)		-62		dB
Crosstalk	$V_{CT}$	$R_S = R_L = 50\Omega$ , $V_{COM\_} = 0.6V_{P-P}$ , $f = 1MHz$ (Note 8)		-80		dB
Thermal Shutdown	$T_{SDW}$			150		$^{\circ}C$
Thermal Hysteresis	$T_{HYST}$			25		$^{\circ}C$
<b>SPI TIMING CHARACTERISTICS (See Figure 12)</b>						
SCLK Clock Period	$t_{CH} + t_{CL}$		95			ns
SCLK Pulse-Width High	$t_{CH}$		35			ns
SCLK Pulse-Width Low	$t_{CL}$		45			ns
$\overline{CS}$ Fall to SCLK Rise Time	$t_{CSS}$		15			ns
DIN Hold Time	$t_{DH}$		15			ns
DIN Setup Time	$t_{DS}$		15			ns
Output Data Propagation Delay	$t_{DO}$	$C_L = 15pF$ , $V_{CC} \geq 2.7V$			40	ns
		$C_L = 15pF$ , $1.6V \leq V_{CC} < 2.7V$			80	
DOUT Rise and Fall Times	$t_{FT}$	$C_L = 15pF$		10		ns
$\overline{CS}$ Hold Time	$t_{CSH}$		60			ns
<b>I<sup>2</sup>C TIMING (See Figure 4)</b>						
I <sup>2</sup> C Serial-Clock Frequency	$f_{SCL}$				400	kHz
Bus Free Time Between STOP and START Conditions	$t_{BUF}$		1.3			$\mu s$

## Electrical Characteristics (continued)

( $V_{CC} = +1.6V$  to  $+5.5V$ ,  $T_A = -40^{\circ}C$  to  $+85^{\circ}C$ , unless otherwise noted. Typical values are at  $V_{CC} = +3.3V$ ,  $T_A = +25^{\circ}C$ , unless otherwise noted.) (Note 2)

PARAMETER	SYMBOL	CONDITIONS	MIN	TYP	MAX	UNITS
START Condition Setup Time	$t_{SU:STA}$		0.6			$\mu s$
START Condition Hold Time	$t_{HD:STA}$		0.6			$\mu s$
STOP Condition Setup Time	$t_{SU:STO}$		0.6			$\mu s$
Clock Low Period	$t_{LOW}$		1.3			$\mu s$
Clock High Period	$t_{HIGH}$		0.6			$\mu s$
Data Valid to SCL Rise Time	$t_{SU:DAT}$	Write setup time	100			ns
Data Hold Time to SCL Fall	$t_{HD:DAT}$	Write hold time	0			ns
<b>DIGITAL I/O</b>						
Input Logic-High Voltage	$V_{IH}$		1.4			V
Input Logic-Low Voltage (DIN/SDA, SCLK/SCL, $\overline{CS}/A0$ )	$V_{IL\_FAST}$				0.5	V
Input Logic-Low Voltage (DOUT/A1 $\overline{SD}$ )	$V_{IL\_SLOW}$				0.4	V
Input Leakage Current	$I_{IN}$		-1		+1	$\mu A$
SPI/ $\overline{I}^2C$ I <sup>2</sup> C Threshold	$V_{I2C}$				0.4	V
SPI/ $\overline{I}^2C$ SPI Threshold	$V_{SPI}$		1.5			V
Output Logic Low (I <sup>2</sup> C mode)	$V_{OL\_I2C}$	$I_{SINK} = 3mA$			0.4	V
SPI/ $\overline{I}^2C$ SPI Supply Voltage	$V_{OVDD}$		1.5		5.5	V
Output Logic-Low (SPI Mode)	$V_{OL\_SPI}$	$I_{SINK} = 200\mu A$			$0.15 \times V_{OVDD}$	V
Output Logic-High (SPI Mode)	$V_{OH\_SPI}$	$I_{SOURCE} = 200\mu A$			$0.85 \times V_{OVDD}$	V
<b>ESD PROTECTION</b>						
All AB_ and COM_ Pins		HBM			$\pm 10$	kV
All Others Pins		HBM			$\pm 2$	kV

**Note 2:** All devices are 100% production tested at  $T_A = +25^{\circ}C$ . Specifications over temperature are guaranteed by design.

**Note 3:** Guaranteed by design.

**Note 4:** See the [Typical Operating Characteristics](#) Maximum Signal Amplitude vs. Supply Voltage for  $f > 500kHz$  for more details.

**Note 5:** Test circuit [Figure 1](#).

**Note 6:** Test circuit [Figure 2](#).

**Note 7:** Supply voltage and signal amplitude can affect the frequency response of the device. See amplitude frequency stability in the [Typical Operating Characteristics](#) for more details.

**Note 8:** Test circuit [Figure 3](#).

Test Circuits/Timing Diagrams

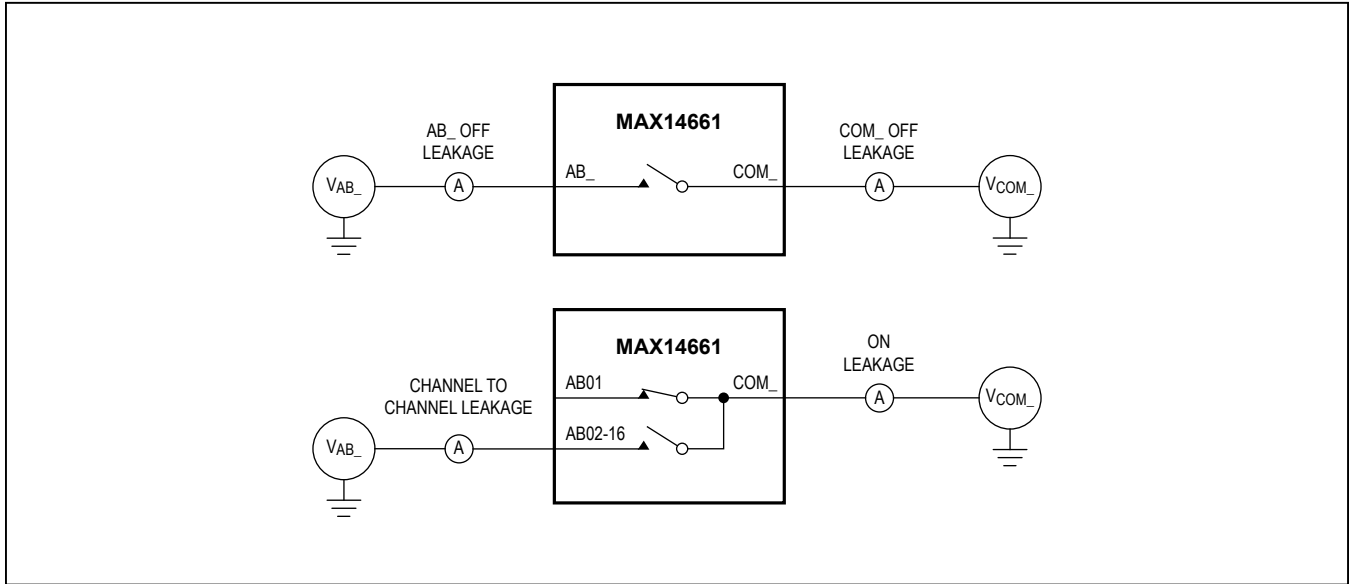

Figure 1. On-/Off-/Channel-to-Channel Leakage Current

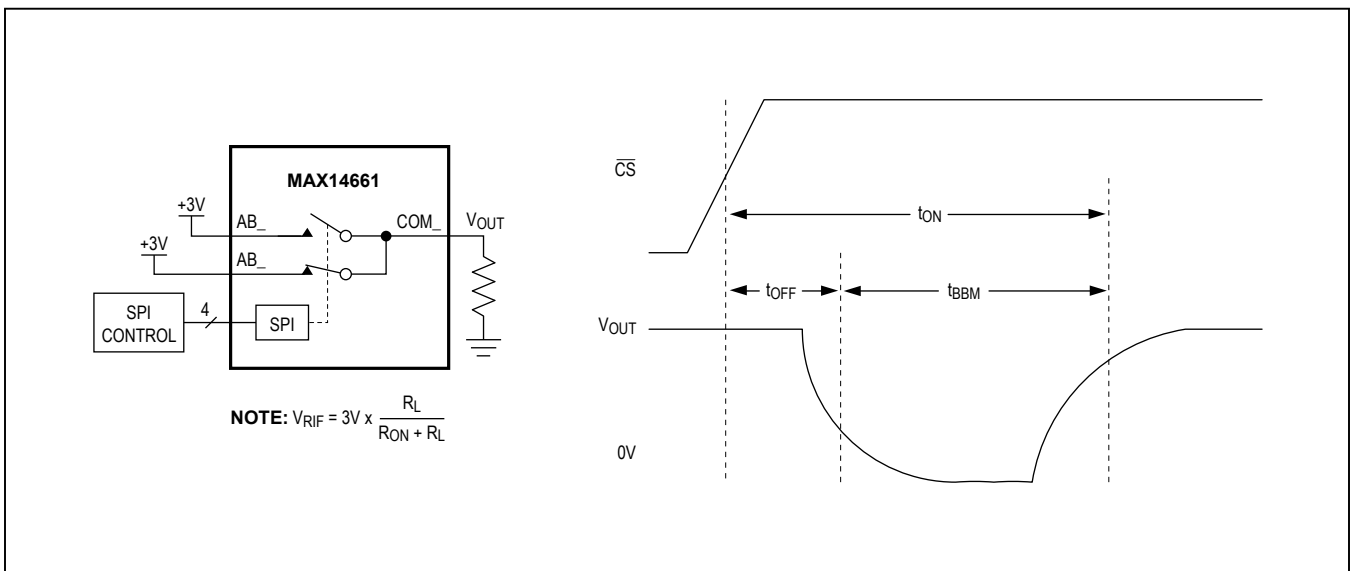

Figure 2. Turn-On/Turn-Off/Break-Before-Make

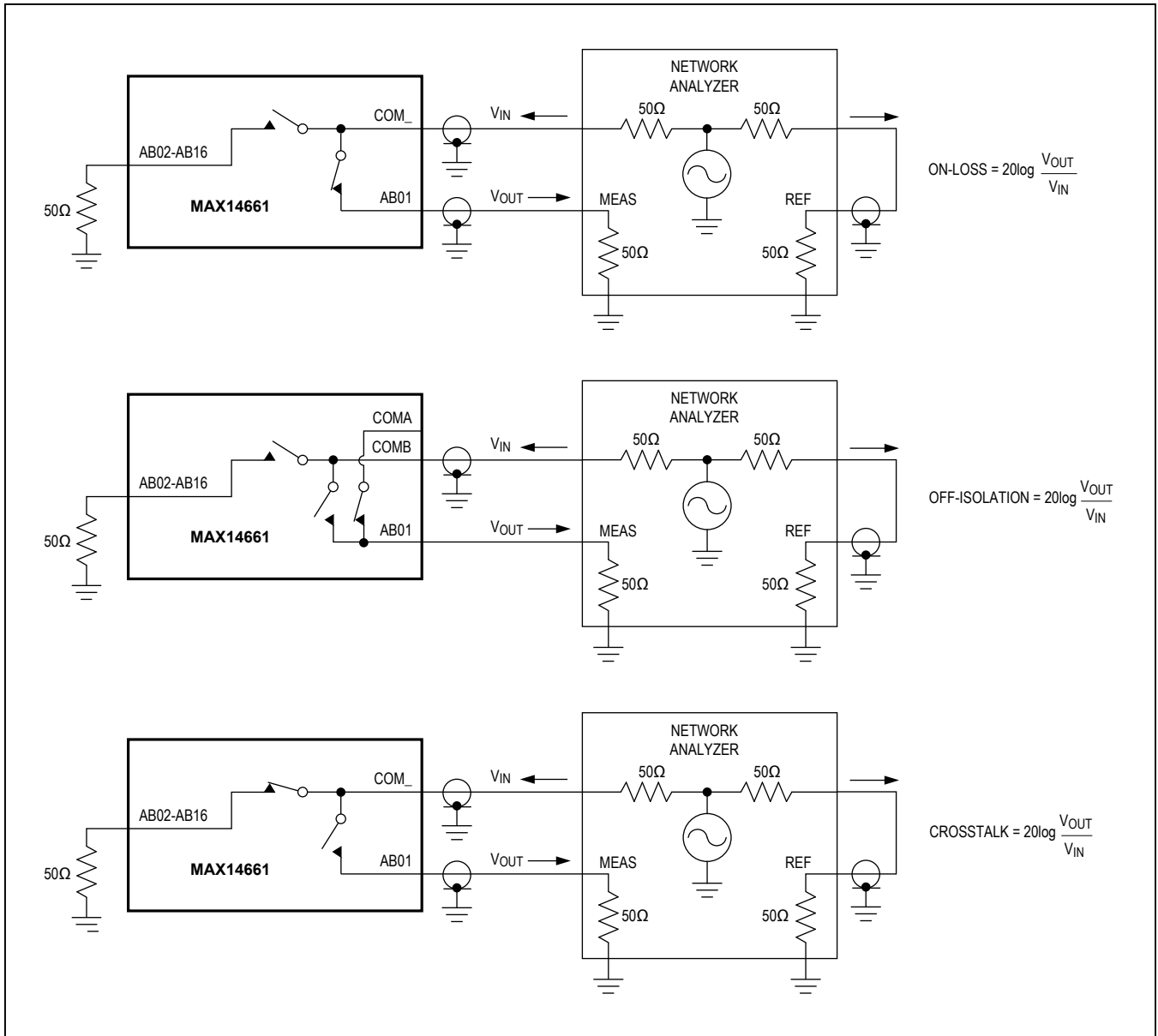
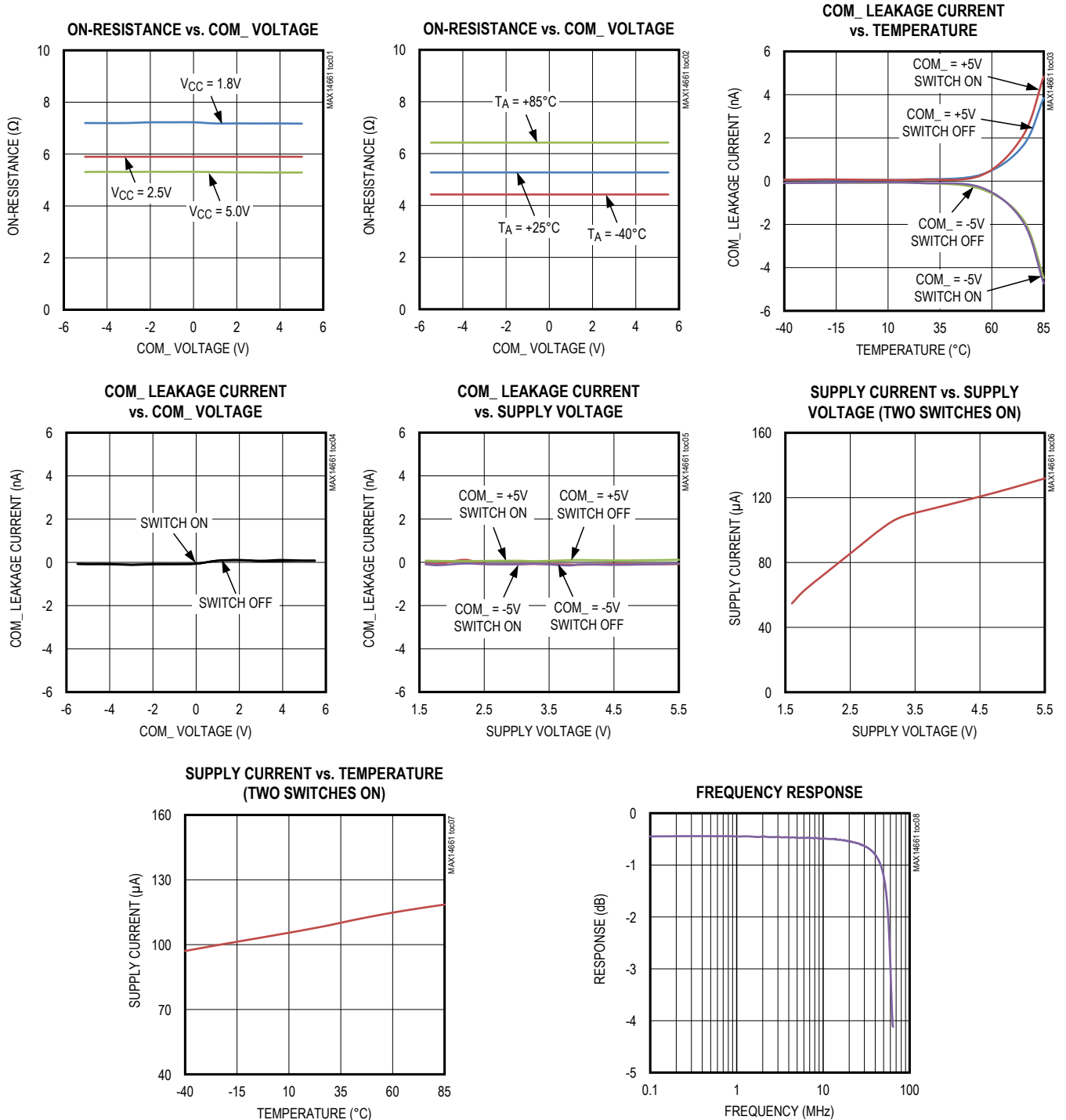

Figure 3. Insertion Loss, Off-Isolation, and Crosstalk

Typical Operating Characteristics

( $V_{CC} = +1.6V$  to  $+5.5V$ ,  $T_A = -40^{\circ}C$  to  $+85^{\circ}C$ , unless otherwise noted. Typical values are at  $V_{CC} = +3.3V$ ,  $T_A = +25^{\circ}C$ , unless otherwise noted.)





**Typical Operating Characteristics (continued)**

( $V_{CC} = +1.6V$  to  $+5.5V$ ,  $T_A = -40^{\circ}C$  to  $+85^{\circ}C$ , unless otherwise noted. Typical values are at  $V_{CC} = +3.3V$ ,  $T_A = +25^{\circ}C$ , unless otherwise noted.)

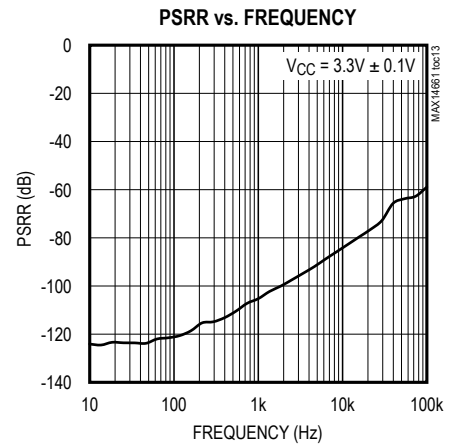
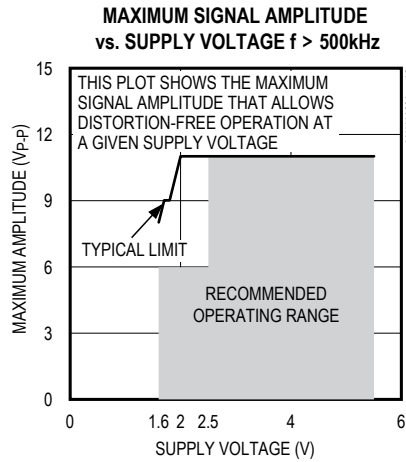
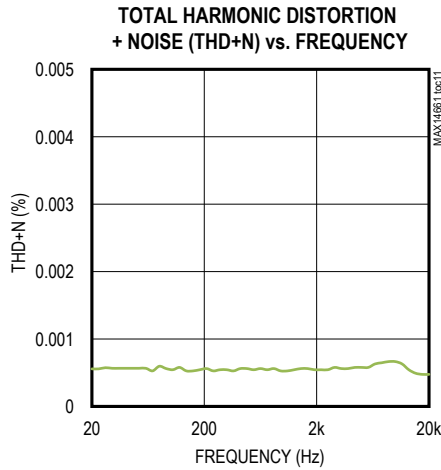
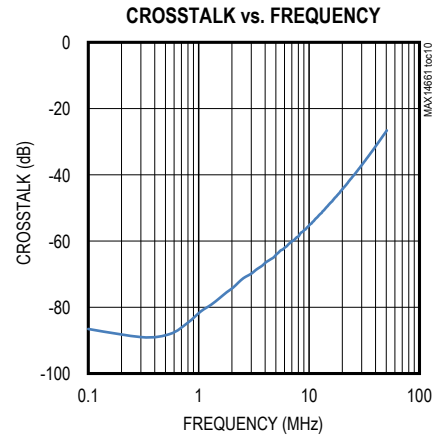
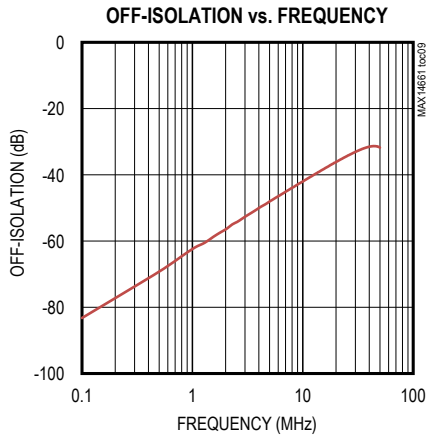

Pin Configurations

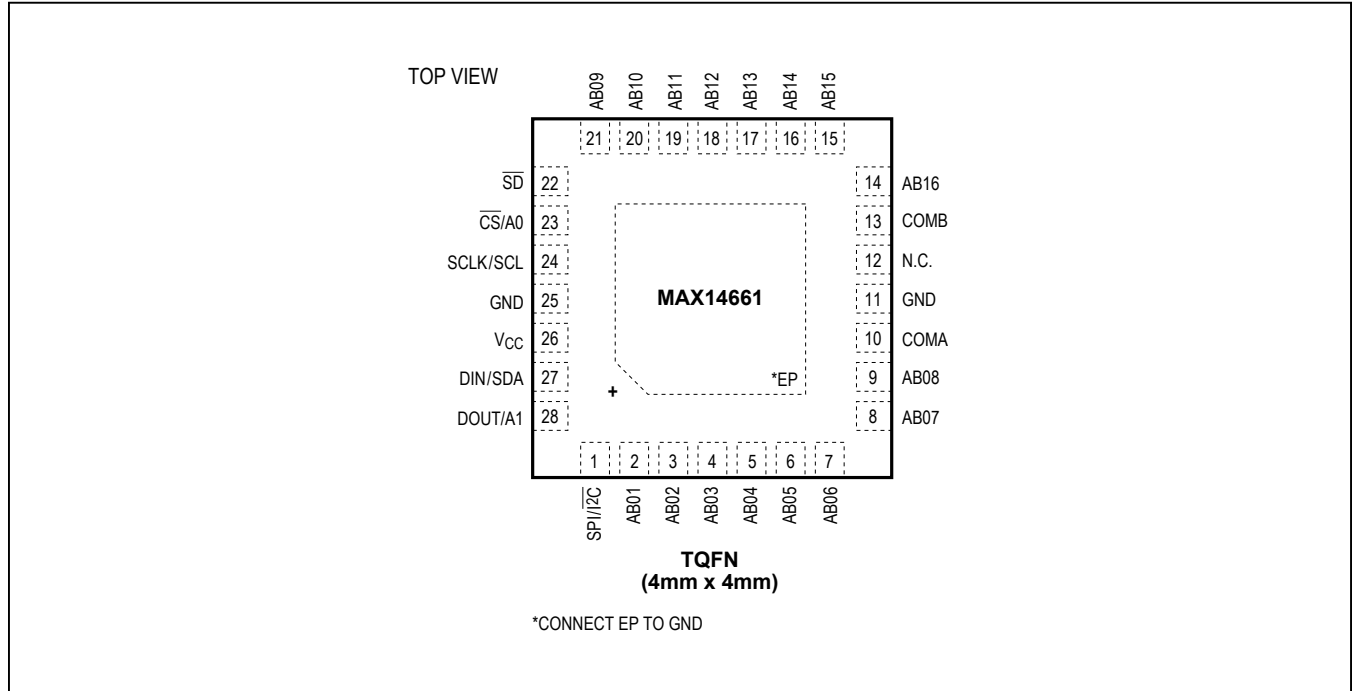

Pin Description

PIN	NAME	FUNCTION
1	SPI/ $\overline{I2C}$	Serial Mode Select SPI (high) or I2C (low), Supply Input for DOUT
2	AB01	AB Connection to Switches 1A and 1B
3	AB02	AB Connection to Switches 2A and 2B
4	AB03	AB Connection to Switches 3A and 3B
5	AB04	AB Connection to Switches 4A and 4B
6	AB05	AB Connection to Switches 5A and 5B
7	AB06	AB Connection to Switches 6A and 6B
8	AB07	AB Connection to Switches 7A and 7B
9	AB08	AB Connection to Switches 8A and 8B
10	COMA	Common Connection to All A Switches

## Pin Description (continued)

PIN	NAME	FUNCTION
11	GND	Ground
12	N.C.	Not Connected
13	COMB	Common Connection to All B Switches
14	AB16	AB Connection to Switches 16A and 16B
15	AB15	AB Connection to Switches 15A and 15B
16	AB14	AB Connection to Switches 14A and 14B
17	AB13	AB Connection to Switches 13A and 13B
18	AB12	AB Connection to Switches 12A and 12B
19	AB11	AB Connection to Switches 11A and 11B
20	AB10	AB Connection to Switches 10A and 10B
21	AB09	AB Connection to Switches 9A and 9B
22	$\overline{SD}$	Active-Low Shutdown/Low-Power Mode, Turns All Switches Off
23	$\overline{CS}/A0$	I <sup>2</sup> C Address Bit 0/SPI $\overline{CS}$ Signal
24	SCLK/SCL	I <sup>2</sup> C Serial Clock/SPI Serial Clock
25	GND	Ground
26	V <sub>CC</sub>	Power-Supply Input
27	DIN/SDA	I <sup>2</sup> C Serial Data/SPI Data Input
28	DOUT/A1	I <sup>2</sup> C Address Bit 1/SPI Data Output
—	EP	Exposed Pad. Internally connected to GND. Connect to a large ground plane to maximize thermal performance. Not intended as an electrical connection point.

**Table 1. Register Map**

ADDRESS	NAME	TYPE	DEFAULT	DESCRIPTION
0x00	DIR0	RW	0x00	Switches 8A–1A direct read/write access
0x01	DIR1	RW	0x00	Switches 16A–9A direct read/write access
0x02	DIR2	RW	0x00	Switches 8B–1B direct read/write access
0x03	DIR3	RW	0x00	Switches 16B–9B direct read/write access
0x10	SHDW0	RW	0x00	Switches 8A–1A shadow read/write access
0x11	SHDW1	RW	0x00	Switches 16A–9A shadow read/write access
0x12	SHDW2	RW	0x00	Switches 8B–1B shadow read/write access
0x13	SHDW3	RW	0x00	Switches 16B–9B shadow read/write access
0x14	CMD_A	RW	0x00	Set mux A command (reads 0x00)
0x15	CMD_B	RW	0x00	Set mux B command (reads 0x00)

Register Types: RW = Read/Write

**Table 2. Detailed Register Map**

<b>DIR0 0x00</b>								
BIT	7	6	5	4	3	2	1	0
BIT Name	Direct_SW8A–1A							
Reset Value	0	0	0	0	0	0	0	0
Description	Direct Register Data for SW8A–1A 0 = Switch open 1 = Switch closed							
<b>DIR1 0x01</b>								
BIT	7	6	5	4	3	2	1	0
BIT Name	Direct_SW16A–9A							
Reset Value	0	0	0	0	0	0	0	0
Description	Direct Register Data for SW16A–9A 0 = Switch open 1 = Switch closed							
<b>DIR2 0x02</b>								
BIT	7	6	5	4	3	2	1	0
BIT Name	Direct_SW8B–1B							
Reset Value	0	0	0	0	0	0	0	0
Description	Direct Register Data for SW8B–1B 0 = Switch open 1 = Switch closed							

**Table 2. Detailed Register Map (continued)**

<b>DIR3 0x03</b>								
BIT	7	6	5	4	3	2	1	0
BIT Name	Direct_SW16B–9B							
Reset Value	0	0	0	0	0	0	0	0
Description	Direct Register Data for SW16B–9B 0 = Switch open 1 = Switch closed							
<b>SHDW0 0x10</b>								
BIT	7	6	5	4	3	2	1	0
BIT Name	Shadow_SW8A–1A							
Reset Value	0	0	0	0	0	0	0	0
Description	Shadow Register Data for SW8A–1A; temporarily holding registers that support simultaneous updates. 0 = Switch open 1 = Switch closed							
<b>SHDW1 0x11</b>								
BIT	7	6	5	4	3	2	1	0
BIT Name	Shadow_SW16A–9A							
Reset Value	0	0	0	0	0	0	0	0
Description	Shadow Register Data for SW16A–9A; temporarily holding registers that support simultaneous updates. 0 = Switch open 1 = Switch closed							
<b>SHDW2 0x12</b>								
BIT	7	6	5	4	3	2	1	0
BIT Name	Shadow_SW8B–1B							
Reset Value	0	0	0	0	0	0	0	0
Description	Shadow Register Data for SW8B–1B; temporarily holding registers that support simultaneous updates. 0 = Switch open 1 = Switch closed							
<b>SHDW3 0x13</b>								
BIT	7	6	5	4	3	2	1	0
BIT Name	Shadow_SW16B–9B							
Reset Value	0	0	0	0	0	0	0	0
Description	Shadow Register Data for SW16B–9B; temporarily holding registers that support simultaneous updates. 0 = Switch open 1 = Switch closed							

**Table 2. Detailed Register Map (continued)**

<b>CMD_A 0x14</b>								
BIT	7	6	5	4	3	2	1	0
BIT Name	RFU	RFU	RFU	SelA				
Reset Value	0	0	0	0	0	0	0	0
Description	SelA 00000 = Enable only SW01A (0x0001) 00001 = Enable only SW02A (0x0002) 00010 = Enable only SW03A (0x0004) 00011 = Enable only SW04A (0x0008) 00100 = Enable only SW05A (0x0010) 00101 = Enable only SW06A (0x0020) 00110 = Enable only SW07A (0x0040) 00111 = Enable only SW08A (0x0080) 01000 = Enable only SW09A (0x0100) 01001 = Enable only SW10A (0x0200) 01010 = Enable only SW11A (0x0400) 01011 = Enable only SW12A (0x0800) 01100 = Enable only SW13A (0x1000) 01101 = Enable only SW14A (0x2000) 01110 = Enable only SW15A (0x4000) 01111 = Enable only SW16A (0x8000) 10000 = Disable all bank A switches (0x0000) 10001 = Copy A shadows registers (SHDW0 and SHDW1) to switches 10010 ..11111 = No change on bank A							
<b>CMD_B 0x15</b>								
BIT	7	6	5	4	3	2	1	0
BIT Name	RFU	RFU	RFU	SelB				
Reset Value	0	0	0	0	0	0	0	0
RFU = Reserved  Description	SelB 00000 = Enable only SW01B (0x0001) 00001 = Enable only SW02B (0x0002) 00010 = Enable only SW03B (0x0004) 00011 = Enable only SW04B (0x0008) 00100 = Enable only SW05B (0x0010) 00101 = Enable only SW06B (0x0020) 00110 = Enable only SW07B (0x0040) 00111 = Enable only SW08B (0x0080) 01000 = Enable only SW09B (0x0100) 01001 = Enable only SW10B (0x0200) 01010 = Enable only SW11B (0x0400) 01011 = Enable only SW12B (0x0800) 01100 = Enable only SW13B (0x1000) 01101 = Enable only SW14B (0x2000) 01110 = Enable only SW15B (0x4000) 01111 = Enable only SW16B (0x8000) 10000 = Disable all bank B switches (0x0000) 10001 = Copy B shadows registers (SHDW2 and SHDW3) to switches 10010 .. 11111 = No change on bank B							

## Detailed Description

### Low-Power Shutdown

The device includes an active-low shutdown pin ( $\overline{SD}$ ). When this pin is low, all registers are cleared and all switches are open. The serial interface is not functional when in shutdown. All switch connections are open and tolerant of the full  $\pm 5.5V$  specified signal range. In this mode the part consumes minimal power.

### SPI Output Supply

The  $SPI/\overline{I}^2C$  pin has a dual purpose. In addition to selecting which serial protocol the part uses, it also functions as the I/O voltage power pin for the SPI DOUT signal. This allows the user to set the output voltage independent of the device supply voltage.

## I<sup>2</sup>C Serial Interface

### Direct Access Registers

The direct access registers (DIR0–DIR3) allow the user to read or write the switches eight at a time. These register addresses support automatic incrementing so they can be read or written sequentially. The switches are updated after the last bit of the byte clocked in.

### Shadow Registers

The shadow registers (SHDW0–SHDW3) provide storage for switch values to allow for simultaneous updates of the switches. Unlike the direct access registers, these registers have no immediate effect until the copy command is issued. The copy command has to be written in CMD\_A and CMD\_B registers. Simply write to the four registers with the desired state of each switch, and then write the appropriate command to registers CMD\_A and CMD\_B to simultaneously apply the values to the switches.

### Set Mux Command Registers

The set mux command registers allow the user to easily select any one single switch in a bank. The CMD\_A register allows the user to turn on one single switch in bank A, to open the entire bank A switches, to copy SHDW0 and SHDW1 registers to DIR0 and DIR1 registers, or to leave bank A as it is (no changes). Similarly, the CMD\_B register allows the user to turn on one single switch in bank B, to open the entire bank B switches, to copy SHDW2 and SHDW3 registers to DIR2 and DIR3 registers, or to leave bank B as it is (no changes). The values apply to the switches after both registers (CMD\_A and CMD\_B) have been written. CMD\_A and CMD\_B are a single 16-bit register; therefore, CMD\_A must be programmed before CMD\_B.

### Serial Addressing

When in I<sup>2</sup>C mode, the MAX14661 operates as a slave device that sends and receives data through an I<sup>2</sup>C-compatible 2-wire interface. The interface uses a serial-data line (SDA) and a serial-clock line (SCL) to achieve bidirectional communication between master(s) and slave(s). A master (typically a microcontroller) initiates all data transfers to and from the MAX14661 and generates the SCL clock that synchronizes the data transfer. The SDA line operates as both an input and an open-drain output. A pullup resistor is required on SDA. The SCL line operates only as an input. A pullup resistor is required on SCL if there are multiple masters on the 2-wire interface, or if the master in a single-master system has an open-drain SCL output. Each transmission consists of a START condition sent by a master, followed by the MAX14661 7-bit slave address plus R/W bit, a register address byte, one or more data bytes, and finally a STOP condition (Figure 4).

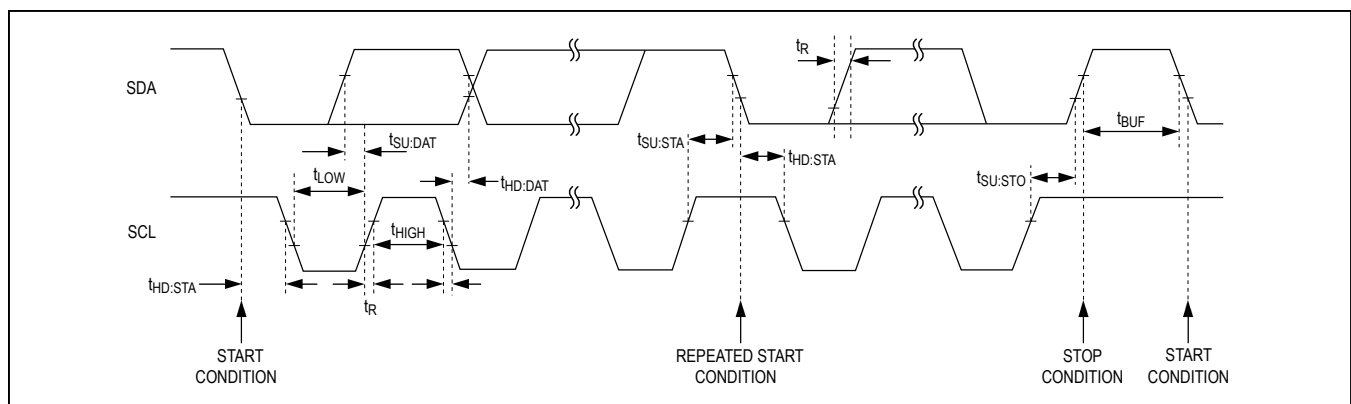

Figure 4. I<sup>2</sup>C Interface Timing Details

### Start and Stop Conditions

Both SCL and SDA remain high when the interface is not busy. A master signals the beginning of a transmission with a START (S) condition by transitioning SDA from high to low while SCL is high (Figure 5). When the master has finished communicating with the slave, it issues a STOP (P) condition by transitioning SDA from low to high while SCL is high. The bus is then free for another transmission.

### Bit Transfer

One data bit is transferred during each clock pulse (Figure 6). The data on SDA must remain stable while SCL is high.

### Acknowledge

The acknowledge bit is a clocked 9th bit (Figure 7), which the recipient uses to handshake receipt of each byte of data. Thus, each byte transferred effectively requires 9

bits. The master generates the 9th clock pulse, and the recipient pulls down SDA during the acknowledge clock pulse. The SDA line is stable low during the high period of the clock pulse. When the master is transmitting to the MAX14661, it generates the acknowledge bit because the device is the recipient. When the device is transmitting to the master, the master generates the acknowledge bit because the master is the recipient. If the device did not pull SDA low, a not acknowledge is indicated.

### Slave Address

The MAX14661 features a 7-bit slave address, configured by the A0 and A1 inputs. To select the slave address, connect A0 and A1 to GND or V<sub>CC</sub>, as indicated in Table 3. The IC has four possible addresses, allowing up to four MAX14661 devices to share the same interface bus. The bit following a 7-bit slave address is the R/W bit, which is low for a write command and high for a read command.

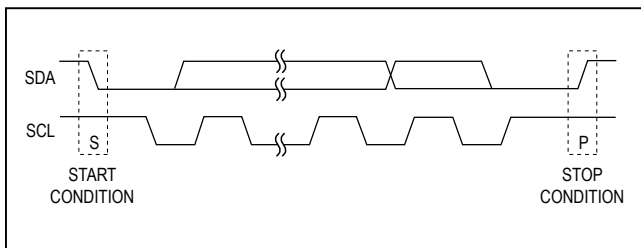

Figure 5. Start and Stop Conditions

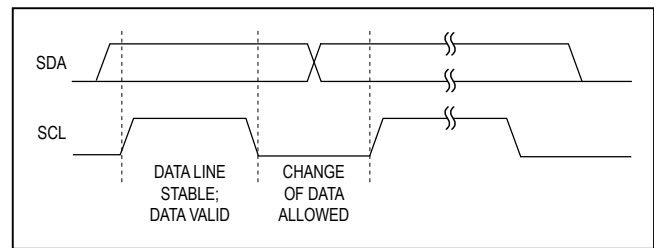

Figure 6. Bit Transfer

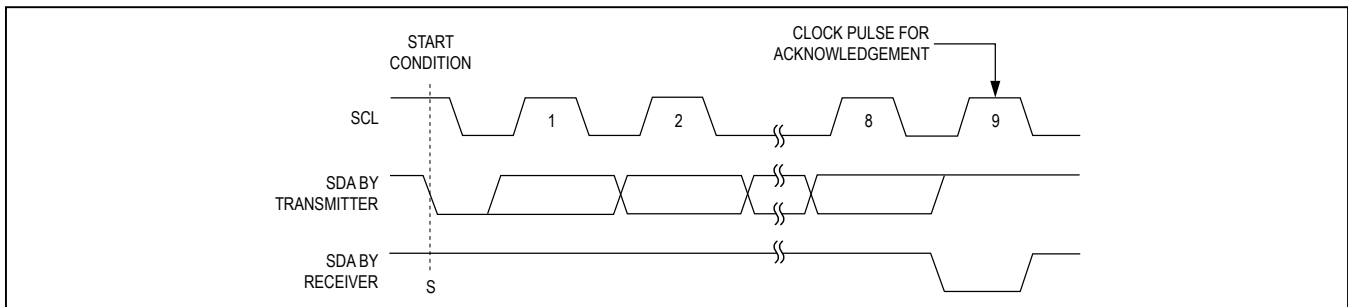

Figure 7. Acknowledge

Table 3. Slave Address Configuration

LOGIC INPUTS		I2C SLAVE ADDRESS									
A1	A0	A6	A5	A4	A3	A2	A1	A0	R/W	READ ADD	WRITE ADD
0	0	1	0	0	1	1	0	0	1/0	0X99	0X98
0	1	1	0	0	1	1	0	1	1/0	0X9B	0X9A
1	0	1	0	0	1	1	1	0	1/0	0X9D	0X9C
1	1	1	0	0	1	1	1	1	1/0	0X9F	0X9E



**Bus Reset**

The MAX14661 resets the bus with the I<sup>2</sup>C start condition for reads. When the R/W bit is set to 1, the device transmits data to the master, thus the master is reading from the device.

**Format for Writing**

A write to the MAX14661 comprises the transmission of the slave address with the R/W bit set to zero, followed by at least 1 byte of information. The first byte of information is the register address or command byte. The register address determines which register of the device is to be written by the next byte, if received. If a STOP (P) condition is detected after the register address is received, then the device takes no further action beyond storing the register address. Any bytes received after the register address are data bytes. The first data byte goes into the register selected by the register address and subsequent

data bytes go into subsequent registers (Figure 8). If multiple data bytes are transmitted before a STOP condition, these bytes are stored in subsequent registers because the register addresses autoincrement (Figure 9).

**Format for Reading**

The MAX14661 is read using the internally stored register address as an address pointer, the same way the stored register address is used as an address pointer for a write. The pointer autoincrements after each data byte is read using the same rules as for a write. Thus, a read is initiated by first configuring the register address by performing a write (Figure 10). The master can now read consecutive bytes from the device, with the first data byte being read from the register addressed pointed by the previously written register address (Figure 11). Once the master sounds a NACK, the MAX14661 stops sending valid data.

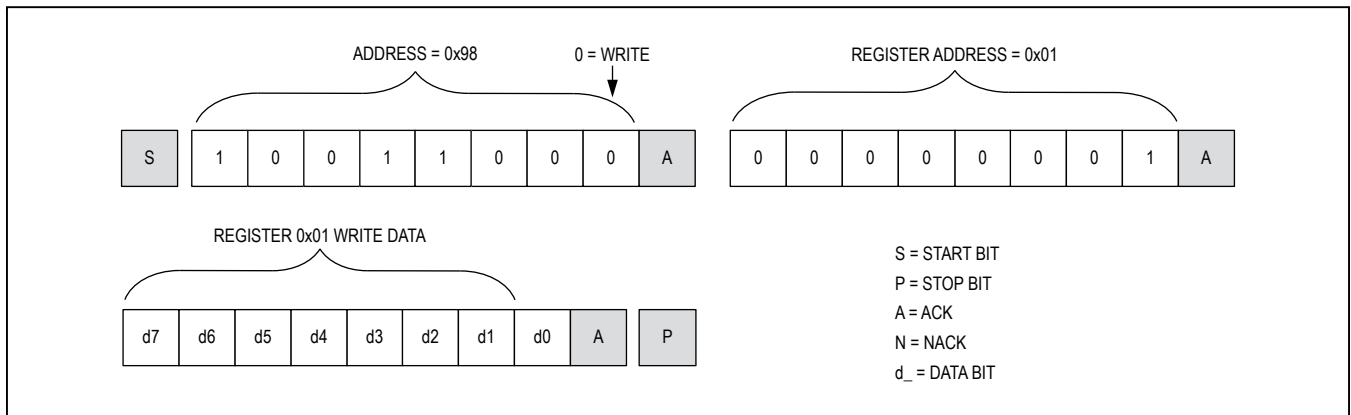

Figure 8. Format for I<sup>2</sup>C Write

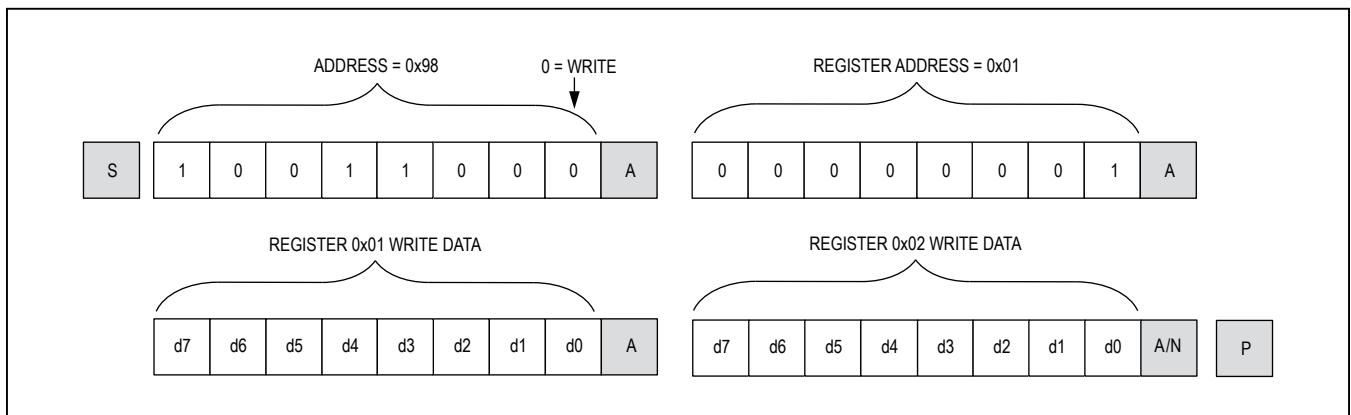

Figure 9. Format for Writing to Multiple Registers

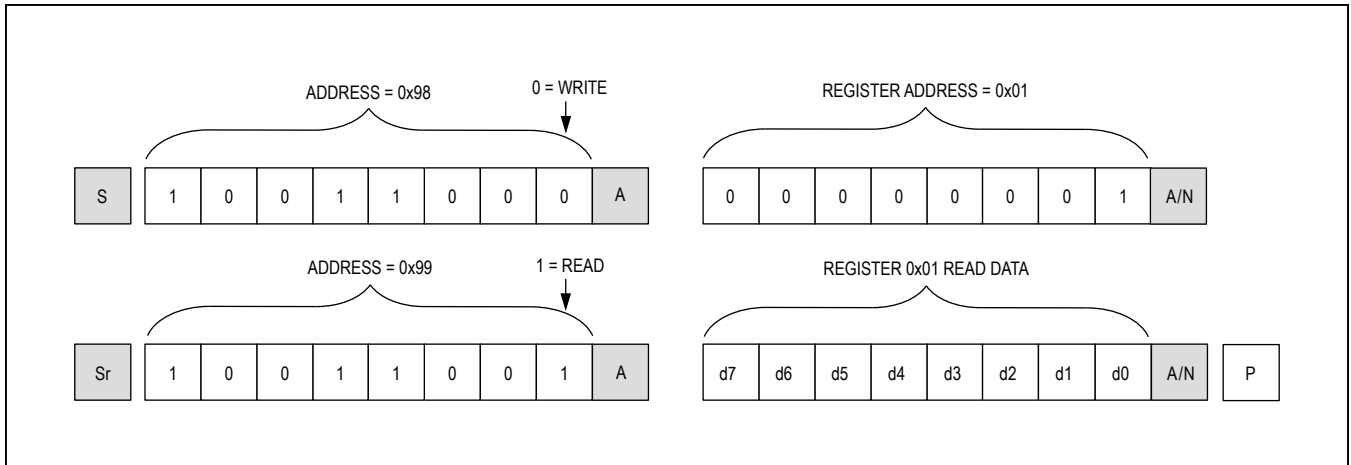

Figure 10. Format for Reads (Repeated Start)

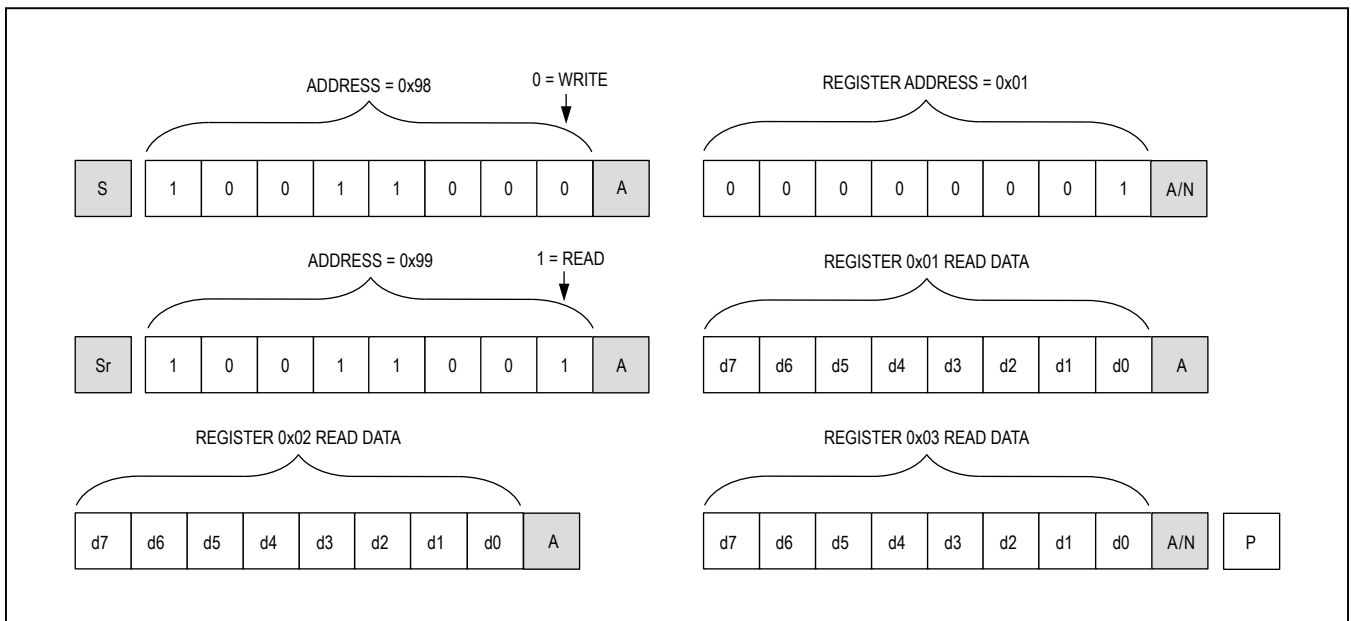

Figure 11. Format for Reading Multiple Registers

### SPI Interface

In SPI mode, the device operates a shift register designed to work with common serial interfaces. The bits are shifted through so that a large serial chain can be made to minimize pins needed for a system with multiple devices. (See [Figure 12](#).) This shift register is also designed to be compatible with common microcontroller SPI-type interfaces. The switches in the MAX14661 are all transitioned simultaneously. To update the switches in SPI mode, the user must shift in a bit with the desired state of each switch according to the data format listed in [Table 4](#). The switches are updated at the rising edge of  $\overline{CS}$  with the last 32 bits of data shifted in **only if the number of bits clocked in is greater than or equal to the number of switches (32)**. The DOUT pin is the serial output of the shift register. This outputs the data loaded into DIN, delayed by 32 clocks, and is intended for creating a serial daisy chain to minimize the number select lines required

by the SPI interface. The first 32 bits out of DOUT after the falling edge of  $\overline{CS}$  are the contents of the shift register prior to  $\overline{CS}$  falling, followed by the data being clocked into DIN. The bits in the shift register are all zero when power is applied or after shutdown is released.

Note that the data in the shift register may not be the same as the state of the switches. The DOUT pin is intended for daisy chain applications and not for switch readback. Note for  $V_{CC}$  less than 2.7V, the DOUT propagation delay can limit the maximum SPI operating frequency. See [Figures 12](#) and [13](#) for the SPI timing diagrams. The voltage level driven out by the DOUT buffer is set by the voltage applied to  $SPI/\overline{I}^2C$ . This allows the voltage to be independent from the supply voltage. While we expect the voltage at  $SPI/\overline{I}^2C$  to be less than or equal to  $V_{CC}$  in most applications, it can be higher than  $V_{CC}$  as long as it does not exceed  $V_{CC}$  before  $V_{CC}$  has reached at least 1.8V.

**Table 4. SPI Data Format**

BYTE	BIT7	BIT6	BIT5	BIT4	BIT3	BIT2	BIT1	BIT0
First	SW16B	SW15B	SW14B	SW13B	SW12B	SW11B	SW10B	SW09B
Second	SW08B	SW07B	SW06B	SW05B	SW04B	SW03B	SW02B	SW01B
Third	SW16A	SW15A	SW14A	SW13A	SW12A	SW11A	SW10A	SW09A
Fourth	SW08A	SW07A	SW06A	SW05A	SW04A	SW03A	SW02A	SW01A

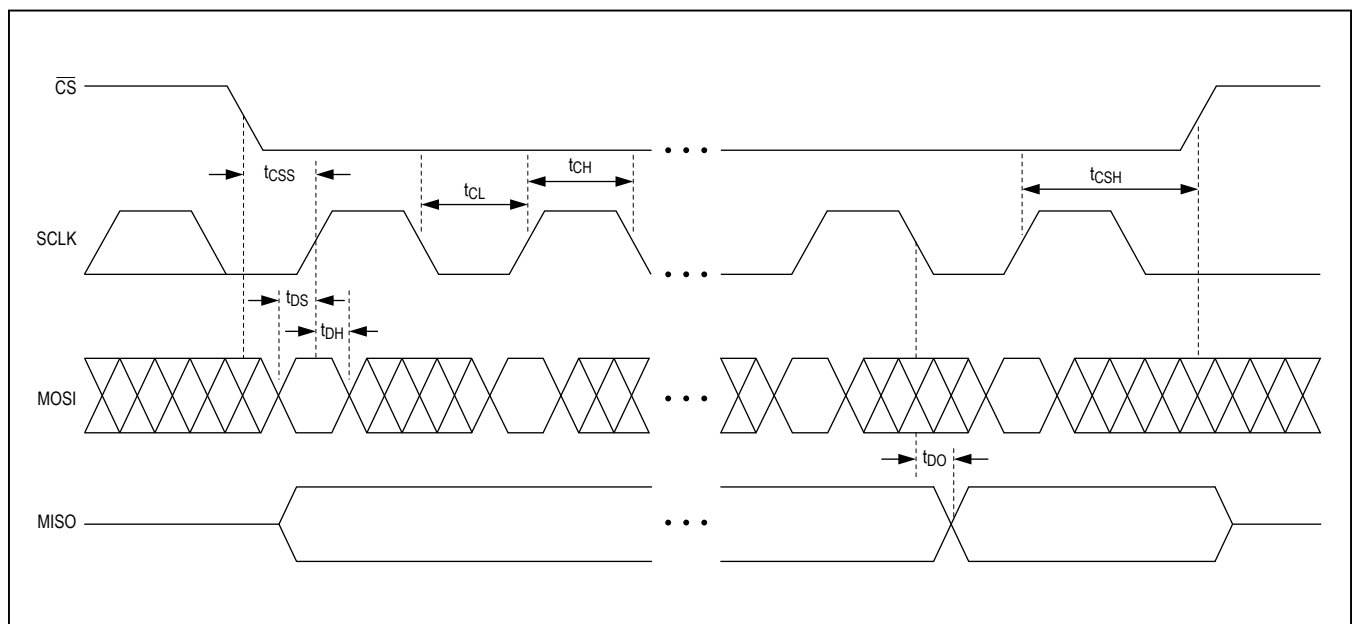

Figure 12. SPI Timing Details

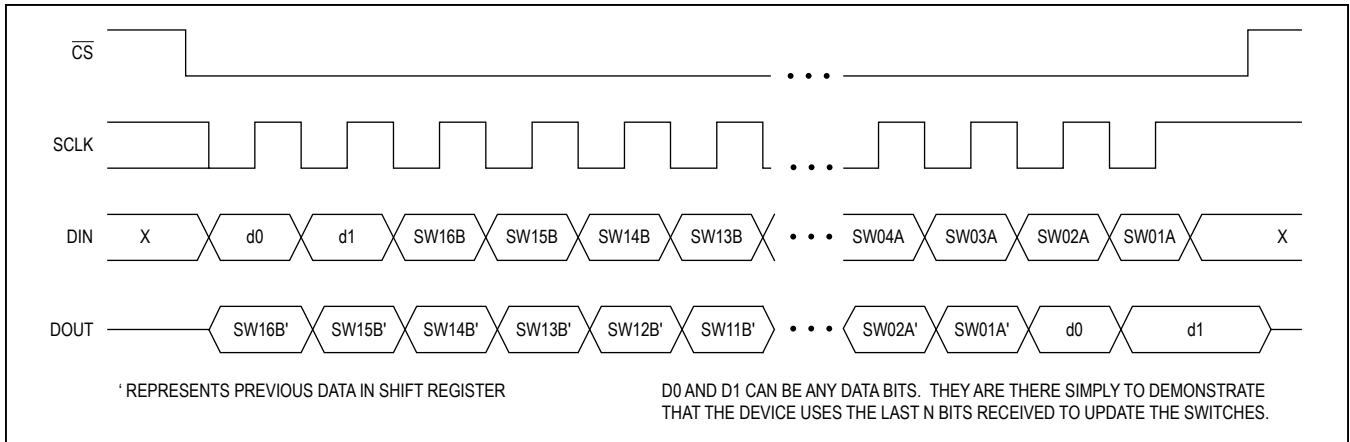

Figure 13. SPI Timing Diagram

### Applications Information

#### Serial Bus Configurations

The MAX14661 was designed to support a wide variety of multiplexing applications. Multiple devices can be used in a system to expand the number of ports being multiplexed. With the two address-select pins provided in I<sup>2</sup>C mode, four devices can be attached to the same I<sup>2</sup>C bus simultaneously using only two pins. There are also several options for addressing multiple devices when using the SPI interface. Using only three pins on the microcon-

troller, as many devices as desired can be loaded by connecting all the CS and SCK pins in parallel and chaining the DOUT pin from one device to the DIN pin on the next. It is also acceptable to provide a separate CS pin for each device so that they can be individually addressed and loaded. Alternatively a separate data line can be used for each device to reduce the time required to load all the devices. Some of the options and tradeoffs are listed in [Table 5](#), as well as example application diagrams in the [Typical Application Circuit](#).

Table 5. Benefits and Limitations of Different Serial-Bus Configurations

SERIAL BUS	PINS	BENEFITS	LIMITATIONS
I <sup>2</sup> C (Figure 16)	2	Fewest Pins	Maximum four devices per bus, slow protocol, no simultaneous updates across all devices
SPI Daisy Chain (Figure 19)	3	Faster than I <sup>2</sup> C with only one additional pin, simultaneous updates across all devices in chain	n x 32 clocks required to load all devices
SPI Separate CS (Figure 17)	n+2	Common SPI implementation, quick for single device updates	n x 32 clocks required to load all devices, requires an additional pin per device, no simultaneous updates across all devices
SPI Separate Data (Figure 18)	n+2	Fastest loading for multiple devices, simultaneous updates across all devices	Requires an additional pin per device, may not be supported by SPI controller

**Extended ESD**

ESD protection structures are incorporated on all pins to protect against electrostatic discharges up to  $\pm 2\text{kV}$  (HBM) encountered during handling and assembly. AB\_ and COM\_ are further protected against ESD up to  $\pm 10\text{kV}$  (HBM) without damage. The ESD structures withstand high ESD both in normal operation and when the device is powered down. After an ESD event, the MAX14661 continues to function without latchup.

**ESD Test Conditions**

ESD performance depends on a variety of conditions. Contact Maxim for a reliability report that documents test setup, test methodology, and test results.

**Human Body Model**

Figure 14 shows the Human Body Model. Figure 15 shows the current waveform it generates when discharged into a low impedance. This model consists of a 100pF capacitor charged to the ESD voltage of interest that is then discharged into the device through a 1.5k $\Omega$  resistor.

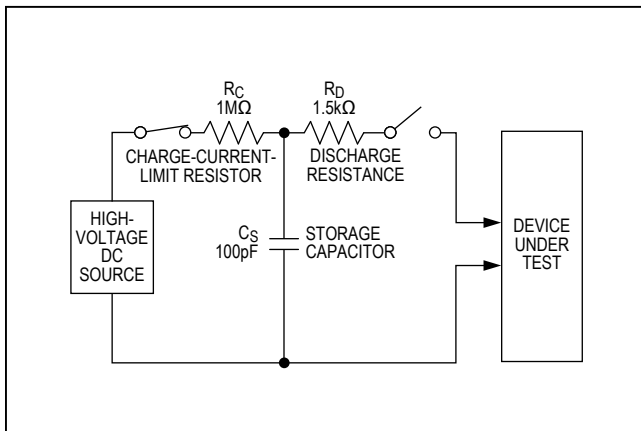

Figure 14. Human Body ESD Test Model

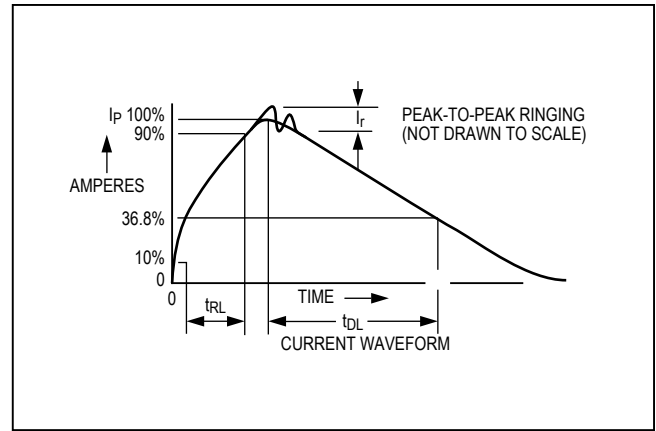

Figure 15. Human Body Current Waveform

Typical Application Circuit

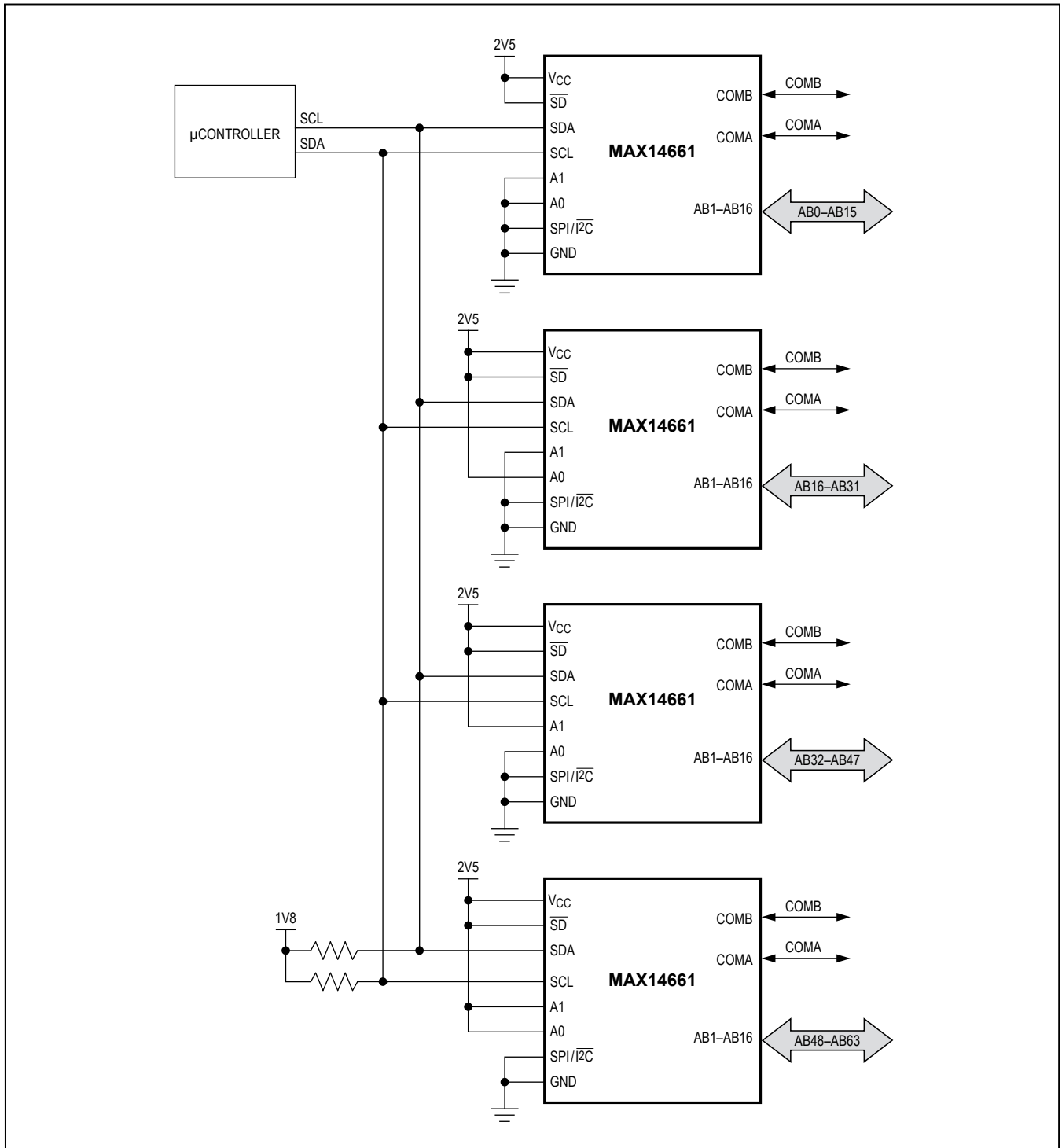

Figure 16. I<sup>2</sup>C Controlled 64:2 MUX

Typical Application Circuit (continued)

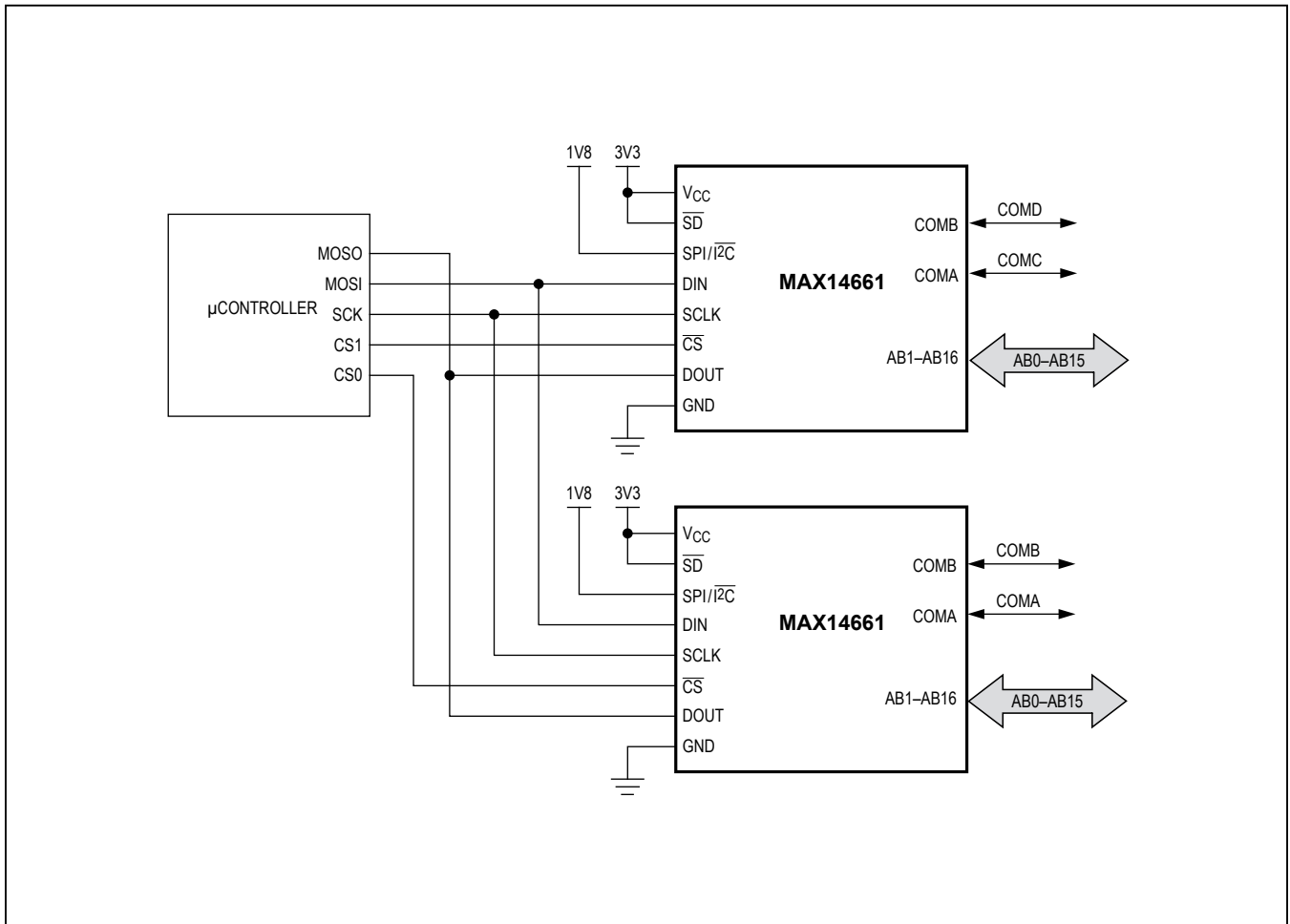

Figure 17. SPI Separate  $\overline{CS}$  16:4





Typical Application Circuit (continued)

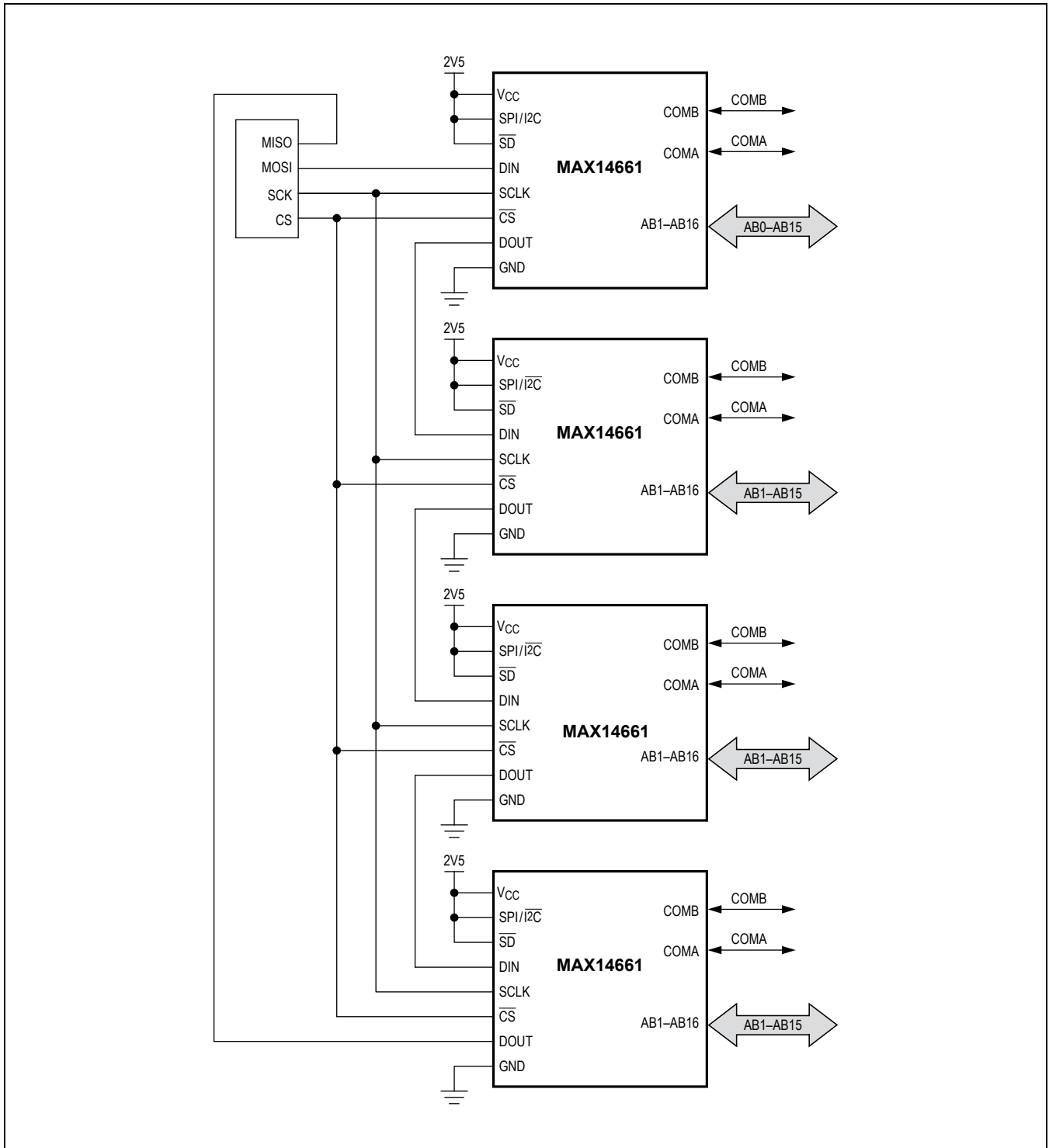

Figure 19. SPI Daisy Chain 256:2 MUX

## Ordering Information

PART	TEMP RANGE	PIN-PACKAGE
MAX14661ETI+	-40°C to +85°C	28 TQFN 4mm x 4mm
MAX14661ETI+T	-40°C to +85°C	28 TQFN 4mm x 4mm

+Denotes lead(Pb)-free/RoHS-compliant package.

T = Tape and reel

\*EP = Exposed Pad.

## Chip Information

PROCESS: BICMOS

## Package Information

For the latest package outline information and land patterns (footprints), go to [www.maximintegrated.com/packages](http://www.maximintegrated.com/packages). Note that a "+", "#", or "-" in the package code indicates RoHS status only. Package drawings may show a different suffix character, but the drawing pertains to the package regardless of RoHS status.

PACKAGE TYPE	PACKAGE CODE	OUTLINE NO.	LAND PATTERN NO.
28 TQFN-EP	T2844+1	<a href="#">21-0139</a>	<a href="#">90-0035</a>

## Revision History

REVISION NUMBER	REVISION DATE	DESCRIPTION	PAGES CHANGED
0	6/13	Initial release	—
1	1/14	Added MAX14661ETI+	26
2	1/15	Updated page 1 content	1

For pricing, delivery, and ordering information, please contact Maxim Direct at 1-888-629-4642, or visit Maxim Integrated's website at [www.maximintegrated.com](http://www.maximintegrated.com).

*Maxim Integrated cannot assume responsibility for use of any circuitry other than circuitry entirely embodied in a Maxim Integrated product. No circuit patent licenses are implied. Maxim Integrated reserves the right to change the circuitry and specifications without notice at any time. The parametric values (min and max limits) shown in the Electrical Characteristics table are guaranteed. Other parametric values quoted in this data sheet are provided for guidance.*



Компания «ЭлектроПласт» предлагает заключение долгосрочных отношений при поставках импортных электронных компонентов на взаимовыгодных условиях!

Наши преимущества:

- Оперативные поставки широкого спектра электронных компонентов отечественного и импортного производства напрямую от производителей и с крупнейших мировых складов;
- Поставка более 17-ти миллионов наименований электронных компонентов;
- Поставка сложных, дефицитных, либо снятых с производства позиций;
- Оперативные сроки поставки под заказ (от 5 рабочих дней);
- Экспресс доставка в любую точку России;
- Техническая поддержка проекта, помощь в подборе аналогов, поставка прототипов;
- Система менеджмента качества сертифицирована по Международному стандарту ISO 9001;
- Лицензия ФСБ на осуществление работ с использованием сведений, составляющих государственную тайну;
- Поставка специализированных компонентов (Xilinx, Altera, Analog Devices, Intersil, Interpoint, Microsemi, Aeroflex, Peregrine, Syfer, Eurofarad, Texas Instrument, Miteq, Cobham, E2V, MA-COM, Hittite, Mini-Circuits, General Dynamics и др.);

Помимо этого, одним из направлений компании «ЭлектроПласт» является направление «Источники питания». Мы предлагаем Вам помощь Конструкторского отдела:

- Подбор оптимального решения, техническое обоснование при выборе компонента;
- Подбор аналогов;
- Консультации по применению компонента;
- Поставка образцов и прототипов;
- Техническая поддержка проекта;
- Защита от снятия компонента с производства.



#### Как с нами связаться

**Телефон:** 8 (812) 309 58 32 (многоканальный)

**Факс:** 8 (812) 320-02-42

**Электронная почта:** [org@eplast1.ru](mailto:org@eplast1.ru)

**Адрес:** 198099, г. Санкт-Петербург, ул. Калинина, дом 2, корпус 4, литера А.