



FCIconnect.com

Copyright FCI.

1

2

List of "HFW\_\_R-1/2STE1LF" customer document

DOCUMENT NO.	LIST
SC-HFWR02	SPEC.
JSA95923	CAT.NO.TABLE FOR 1mm SPACING SMT CONNECTOR (HFW__R-1/2ST_LF)
JSA95924	1mm SPACING SURFACE MOUNT FPC/FFC CONNECTOR (HFW__R-1ST_LF)
JSA95925	1mm SPACING SURFACE MOUNT FPC/FFC CONNECTOR (HFW__R-2ST_LF)
JSA95926	CAT.NO.TABLE FOR PLASTIC TAPE PACKAGED 1mm SPACING SMT CONN.(HFW__R-1/2STE1LF)
JSA95927	1mm SPACING SMT CONNECTOR (HFW__R-1STE1LF)
JSA95928	1mm SPACING SMT CONNECTOR (HFW__R-2STE1LF)
JSA93573	RECOMMENDED CABLE (FPC) (HFW__R-1/2___)
JSA93574	RECOMMENDED CABLE (FFC) (HFW__R-1/2___)
BJM-HFWR101	HANDLING PROCEDURES

mat'l. code				surface <sup>58</sup> ISO 1302 <input checked="" type="checkbox"/>		tolerance ISO 406 ISO 1101		projection		product family 58NF		CODE JP	
ltr	ecn no	dr	date	tolerances unless otherwise specified				mm		title 1mm SPACING FPC/FFC CONNECTOR DOCUMENT LIST (Cat. No. : HFW__R-1/2STE1LF)			
A	J05-0056	H.T	'05/2/4	angles	linear	scale $\propto$							
B	J06-0413	H.T	10/4/'06					scale $\propto$		dwg no JSA 96335		sheet 1 of 1 size A4	
				dr	<i>H. Hoshino</i> 10/24/06				type Product Customer Drawing				
				enr	<i>H. Hoshino</i> 10/20/06								
				chr	<i>J. Gino</i> 10/22/06								
				app	<i>S. Hoshino</i> 10/12/06								
sheet index	revision sheet	B	1									Rev. B	

form: A4

1

2

CAT. NO. & DIMENSIONS

(NOTE3)	NO. OF CONTACTS (n)	CAT. NO.	DIMENSIONS (NOTE2)		
			A ± 0.2	B ± 0.2	C ± 0.1
	4	HFW4R-1/2ST__LF	6.6	3	5.14
	5	HFW5R-1/2ST__LF	7.6	4	6.14
	6	HFW6R-1/2ST__LF	8.6	5	7.14
	7	HFW7R-1/2ST__LF	9.6	6	8.14
	8	HFW8R-1/2ST__LF	10.6	7	9.14
	9	HFW9R-1/2ST__LF	11.6	8	10.14
	10	HFW10R-1/2ST__LF	12.6	9	11.14
	11	HFW11R-1/2ST__LF	13.6	10	12.14
	12	HFW12R-1/2ST__LF	14.6	11	13.14
	13	HFW13R-1/2ST__LF	15.6	12	14.14
	14	HFW14R-1/2ST__LF	16.6	13	15.14
	15	HFW15R-1/2ST__LF	17.6	14	16.14
	16	HFW16R-1/2ST__LF	18.6	15	17.14
	17	HFW17R-1/2ST__LF	19.6	16	18.14
	18	HFW18R-1/2ST__LF	20.6	17	19.14
	19	HFW19R-1/2ST__LF	21.6	18	20.14
	20	HFW20R-1/2ST__LF	22.6	19	21.14
	21	HFW21R-1/2ST__LF	23.6	20	22.14
	22	HFW22R-1/2ST__LF	24.6	21	23.14
	23	HFW23R-1/2ST__LF	25.6	22	24.14
	24	HFW24R-1/2ST__LF	26.6	23	25.14
	25	HFW25R-1/2ST__LF	27.6	24	26.14
	26	HFW26R-1/2ST__LF	28.6	25	27.14
	27	HFW27R-1/2ST__LF	29.6	26	28.14
*	28	HFW28R-1/2ST__LF	30.6	27	29.14
*	29	HFW29R-1/2ST__LF	31.6	28	30.14
	30	HFW30R-1/2ST__LF	32.6	29	31.14

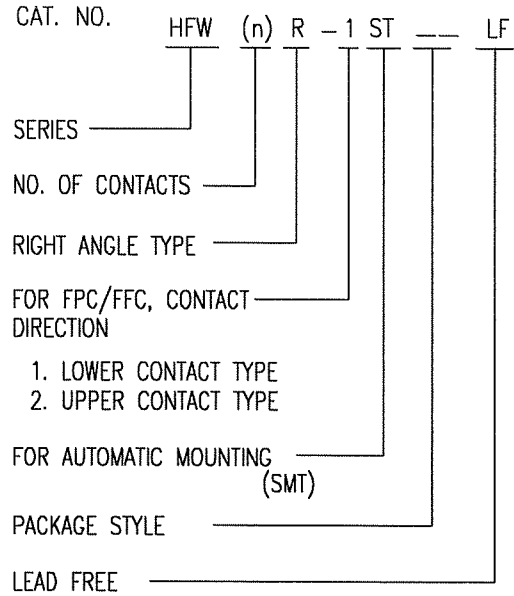

NOTES

1. THIS PRODUCT IS THE CONNECTOR DESIGNED TO TERMINATE FPC/FFC AND COPE WITH AUTOMATIC MOUNTING (SMT).
2. SEE PART DRAWINGS FOR DIMENSIONS A~C.
3. PLEASE CONSULT US IN CASE OF USING PARTS WITH \* MARK.

mat'l. code				surface 58 / ISO 1302		tolerance ISO 406 / ISO 1101		projection		product family 58NF		CODE JP	
ltr				ecn no		dr		date		title		CAT. NO. TABLE FOR 1mm SPACING SMT CONNECTOR (Cat. No. HFW__R-1/2ST__LF)	
A				J04-0027		H.T		4/6/04		mm		scale X	
B				J05-0056		H.T		2/4/05		angles linear		sheet 1 of 1	
C				J06-0413		H.T		10/4/06		FCJ		size A4	
sheet index				revision C		sheet 1				dwg no JSA 95923		type Product Customer Drawing	

SC-HFWR02 JSA95924 95925 95926 95927 95928 93573 93574, 1

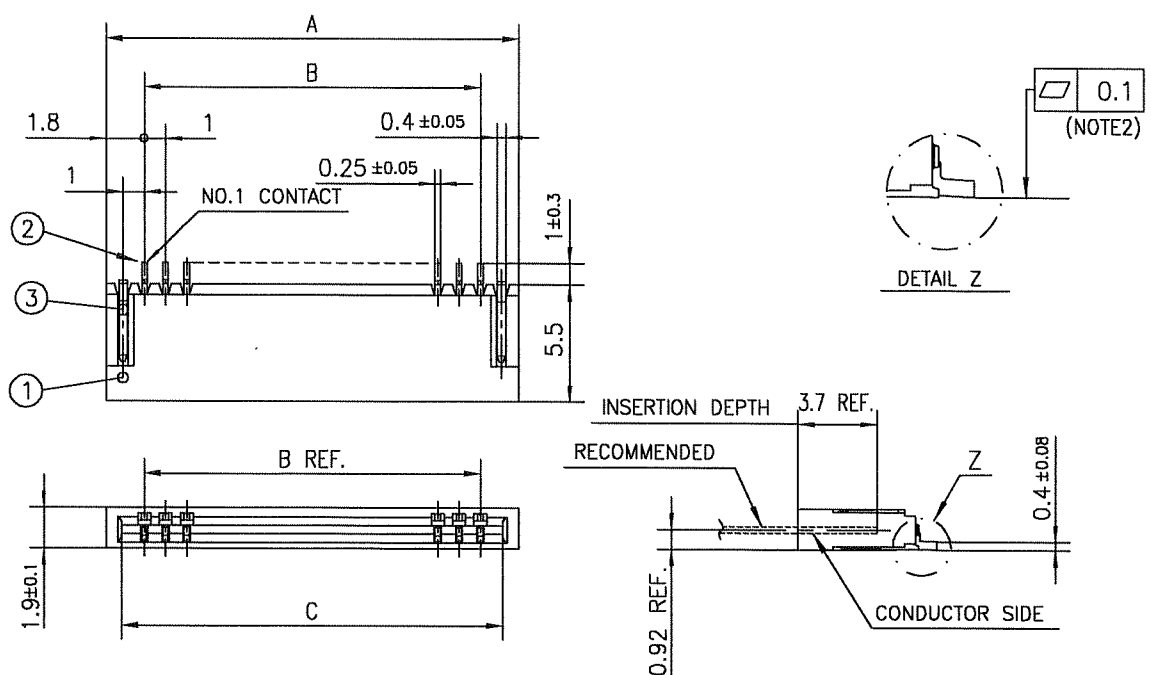

PT. NO.	PARTS NAME	MATERIAL	Q'TY	NOTE
1	HOUSING	PA6T RESIN GLASS REINFORCED (UL94V-0)	1	COLOR:BLACK
2	CONTACT	PHOSPHOR BRONZE	n	PLATING:TIN
3	MOUNTING PLATE		2	(LEAD FREE)

n : NO. OF CONTACTS

RECOMMENDED PC BOARD LAYOUT (COMPONENT SIDE)

BASIC PATTERN NO.1 CONTACT POSITION

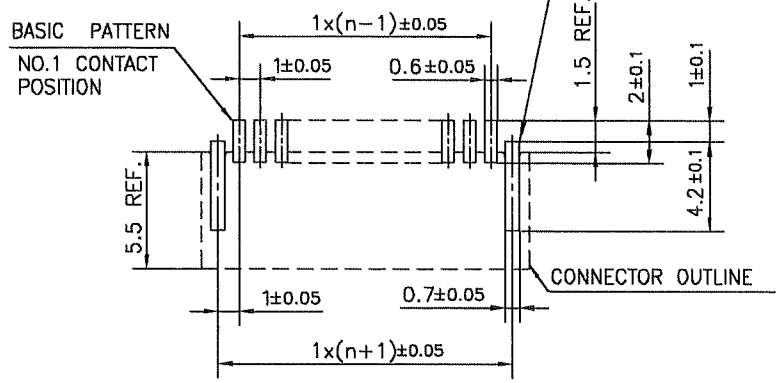

NOTES

1. THIS PRODUCT IS THE CONNECTOR DESIGNED TO TERMINATE FPC/FFC AND COPES WITH AUTOMATIC MOUNTING (SMT).
2. FLATNESS OF CONTACT TERMINAL FOR HOUSING MUST BE WITHIN TOLERANCE IN Z PORTION DETAILED DRAWING.
3. THIS PRODUCT IS LOWER CONTACT TYPE CONNECTOR.
4. THIS PRODUCT MEETS EUROPEAN UNION DIRECTIVES AND OTHER COUNTRY REGULATIONS AS DESCRIBED IN GS-22-008
5. THE HOUSING WILL WITHSTAND EXPOSURE TO 260°C PEAK TEMPERATURE FOR 10 SECONDS IN A REFLOW SOLDERING OVEN.

mat'l. code				surface 58 / ISO 1302	tolerance ISO 406 / ISO 1101	projection	product family 58NF	CODE JP
ltr	ecn no	dr	date	tolerances unless otherwise specified		mm	title	
A	J04-0027	H.T	4/6/04	angles	linear ±0.2		1mm SPACING SURFACE MOUNT FPC/FFC CONNECTOR (Cat.No. HFW__R-1ST__LF)	
B	J05-0056	H.T	2/4/05			scale	dwg no sheet 1 of 1 size	
C	J05-0732	H.T	10/28/05				JSA 95924 A4	
D	J06-0413	H.T	10/4/06	dr	10/14/06		type Product Customer Drawing	
				enrg	10/14/06			
				chr	10/14/06			
				appd	10/14/06			
sheet index	revision sheet	D 1						Rev. D

SC-HFWR02 JSA95923 form: A4



FCIconnect.com

Copyright FCI.

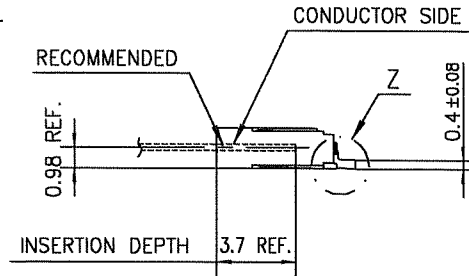
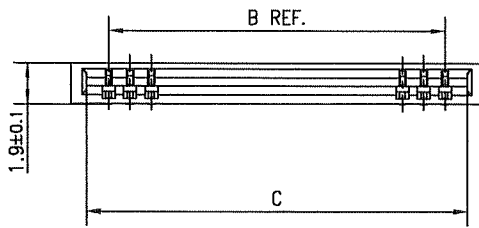
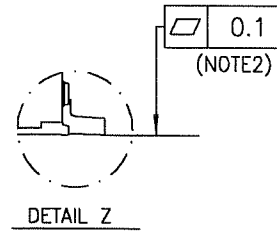
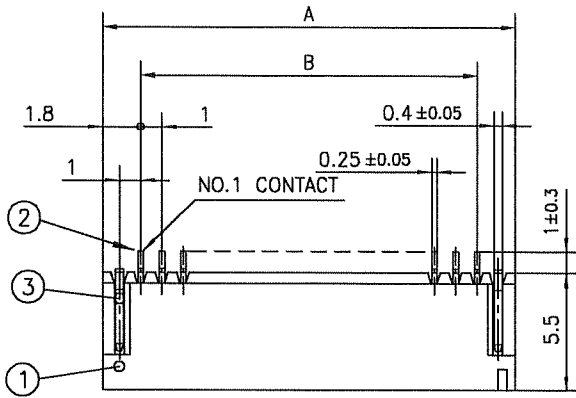

PT. NO.	PARTS NAME	MATERIAL	Q'TY	NOTE
1	HOUSING	PA6T RESIN GLASS REINFORCED (UL94V-0)	1	COLOR:BLACK
2	CONTACT	PHOSPHOR BRONZE	n	PLATING:TIN
3	MOUNTING PLATE		2	(LEAD FREE)

n : NO. OF CONTACTS

RECOMMENDED PC BOARD LAYOUT (COMPONENT SIDE)

BASIC PATTERN

NO.1 CONTACT POSITION

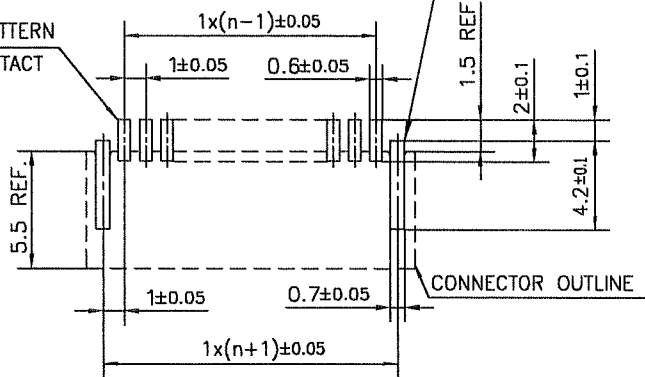

NOTES

1. THIS PRODUCT IS THE CONNECTOR DESIGNED TO TERMINATE FPC/FFC AND COPE WITH AUTOMATIC MOUNTING (SMT).
2. FLATNESS OF CONTACT TERMINAL FOR HOUSING MUST BE WITHIN TOLERANCE IN Z PORTION DETAILED DRAWING.
3. THIS PRODUCT IS UPPER CONTACT TYPE CONNECTOR.
4. THIS PRODUCT MEETS EUROPEAN UNION DIRECTIVES AND OTHER COUNTRY REGULATIONS AS DESCRIBED IN GS-22-008
5. THE HOUSING WILL WITHSTAND EXPOSURE TO 260°C PEAK TEMPERATURE FOR 10 SECONDS IN A REFLOW SOLDERING OVEN.

mat'l. code				surface 58 ISO 1302	tolerance 406 ISO 1101	projection	product family 58NF	CODE JP
ltr	ecn no	dr	date	tolerances unless otherwise specified		mm	title	
A	J04-0027	H.T	4/6/'04	angles	linear ±0.2		1mm SPACING SURFACE MOUNT FPC/FFC CONNECTOR (Cat. No. HFWR_R-2ST_LF)	
B	J05-0056	H.T	2/4/'05			scale	dwg no	sheet 1 of 1
C	J05-0732	H.T	10/28/'05			FCJ	JSA 95925	
D	J06-0413	H.T	10/4/'06	dr			type Product Customer Drawing	
sheet index	revision sheet	D	1					Rev. D

SC-HFWR02 JSA95923 form: A4

CAT. NO. & DIMENSIONS

(NOTE4)	NO. OF CONTACTS (n)	CAT. NO. (NOTE2)	DIMENSIONS (NOTE3)		
			E ± 5	F ± 0.3	G ± 0.1
	4	HFW4R-1/2STE1LF	28.4	24	—
	5	HFW5R-1/2STE1LF	28.4	24	—
	6	HFW6R-1/2STE1LF	28.4	24	—
	7	HFW7R-1/2STE1LF	28.4	24	—
	8	HFW8R-1/2STE1LF	28.4	24	—
	9	HFW9R-1/2STE1LF	28.4	24	—
	10	HFW10R-1/2STE1LF	28.4	24	—
	11	HFW11R-1/2STE1LF	28.4	24	—
	12	HFW12R-1/2STE1LF	28.4	24	—
	13	HFW13R-1/2STE1LF	28.4	24	—
	14	HFW14R-1/2STE1LF	28.4	24	—
	15	HFW15R-1/2STE1LF	36.4	32	28.4
	16	HFW16R-1/2STE1LF	36.4	32	28.4
	17	HFW17R-1/2STE1LF	36.4	32	28.4
	18	HFW18R-1/2STE1LF	36.4	32	28.4
	19	HFW19R-1/2STE1LF	48.4	44	40.4
	20	HFW20R-1/2STE1LF	48.4	44	40.4
	21	HFW21R-1/2STE1LF	48.4	44	40.4
	22	HFW22R-1/2STE1LF	48.4	44	40.4
	23	HFW23R-1/2STE1LF	48.4	44	40.4
	24	HFW24R-1/2STE1LF	48.4	44	40.4
	25	HFW25R-1/2STE1LF	48.4	44	40.4
	26	HFW26R-1/2STE1LF	48.4	44	40.4
	27	HFW27R-1/2STE1LF	48.4	44	40.4
*	28	HFW28R-1/2STE1LF	48.4	44	40.4
*	29	HFW29R-1/2STE1LF	48.4	44	40.4
	30	HFW30R-1/2STE1LF	60.4	56	52.4

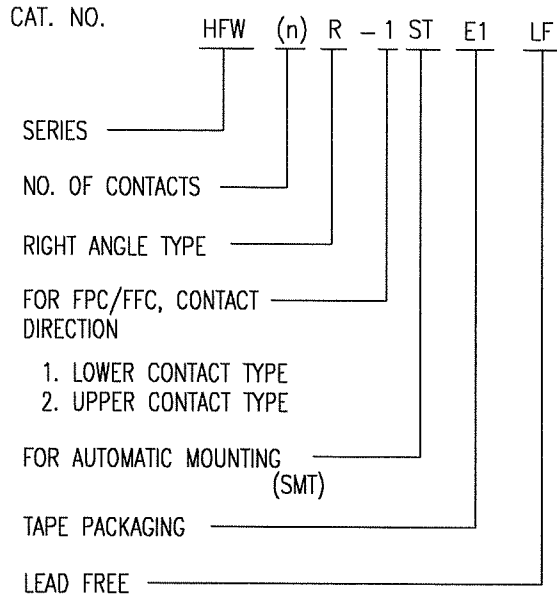

NOTES

1. THIS PRODUCT IS THE CONNECTOR DESIGNED TO TERMINATE FPC/FFC AND COPE WITH AUTOMATIC MOUNTING (SMT).
2. THIS CATALOG NO. INDICATES PLASTIC TAPE PACKAGED CONNECTOR.
3. SEE PART DRAWINGS FOR DIMENSIONS E~G.
4. PLEASE CONSULT US IN CASE OF USING PARTS WITH \* MARK.



FCIconnect.com

Copyright FCI.

mat'l. code				surface 58 / ISO 1302 ✓		tolerance ISO 406 / ISO 1101		projection		product family 58NF		CODE JP	
ltr				ecn no		dr		date		tolerances unless otherwise specified		title	
A				J04-0027		H.T		4/6/04		angles		CAT. NO. TABLE FOR PLASTIC TAPE PACKAGED 1mm SPACING SMT CONN. (Cat.No. HFW__R-1/2STE1LF)	
B				J05-0056		H.T		2/4/05		linear		mm	
C				J06-0413		H.T		10/4/06		scale X		dwg no	
										sheet 1 of 1		size	
										JSA 95926		A4	
										type		Product Customer Drawing	
sheet index		revision C		sheet 1								Rev. C	

SC-HFWR02 JSA95923 95927 95928 form: A4

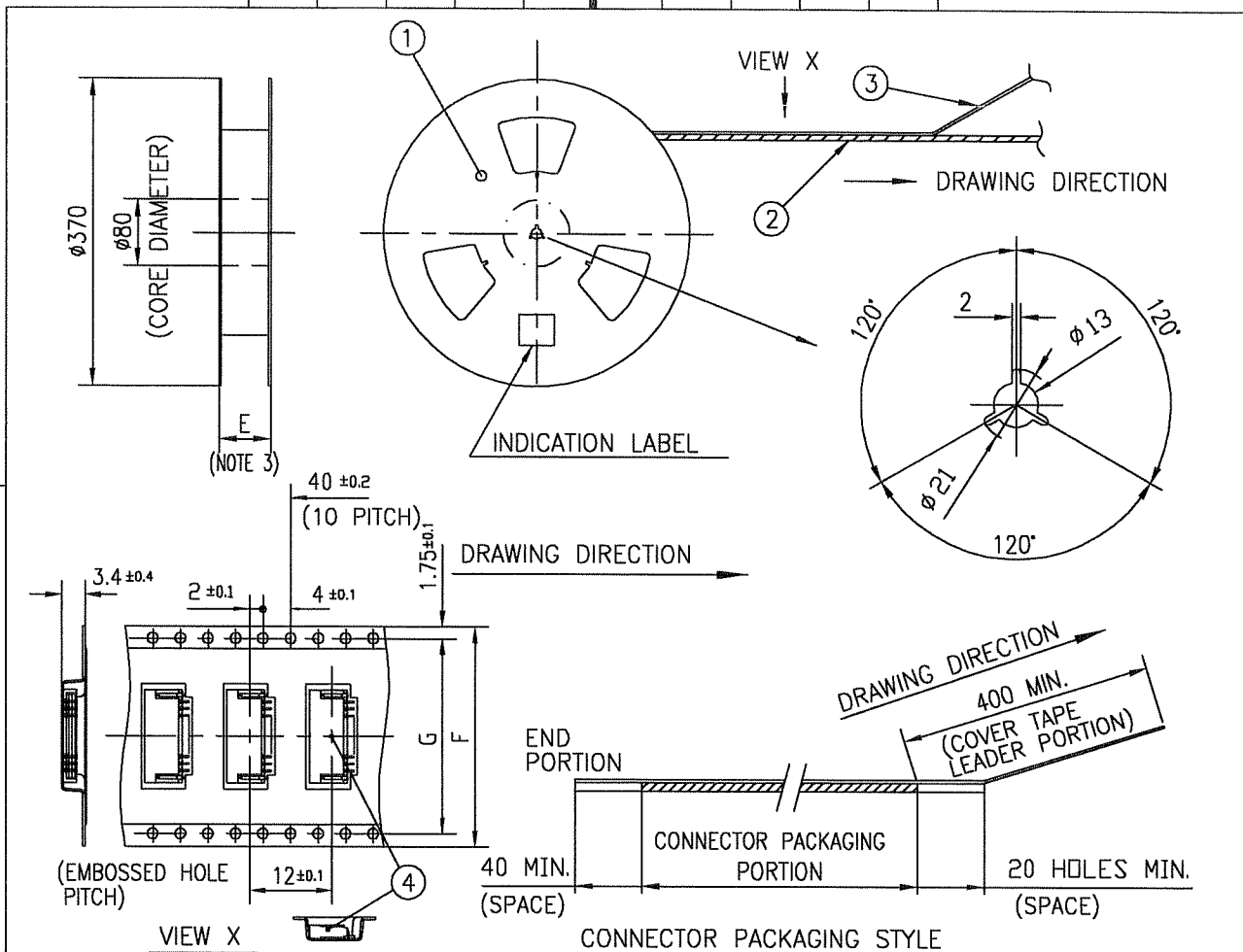

PT. NO.	PARTS NAME	CAT. NO.	MATERIAL	Q'TY	NOTE
1	REEL	—	CARDBOARD	1	COLOR:WHITE
2	PLASTIC (EMBOSSD) TAPE	—	PET	—	COLOR:TRANSPARENCY
3	COVER	—	POLYESTER	—	COLOR:TRANSPARENCY
4	CONNECTOR	HFW__R-1ST__LF	SEE ATTACHED DWG.	2000	LOWER CONTACT TYPE

NOTES

1. THIS IS PLASTIC TAPE PACKAGED CONNECTOR DESIGNED TO TERMINATE FPC/FFC AND COPES WITH AUTOMATIC MOUNTING (SMT).
2. SEE JIS C 0806 (PACKING OF ELECTRONIC COMPONENTS ON CONTINUOUS TAPES (SURFACE MOUNTING DEVICES)) FOR SHAPE AND DIMENSIONS OF PLASTIC (EMBOSSD) TAPE AND REEL.
3. E DIMENSION IS PORTION OF THE CORE.

mat'l. code		surface 58 / tolerance ISO 1302 ✓ / ISO 406 / ISO 1101		projection		product family 58NF		CODE JP	
ltr		ecn no		dr		date		tolerances unless otherwise specified	
A		J04-0027		H.T.		4/6/04		±5	
B		J05-0056		H.T.		2/4/05		angles linear	
C		J06-0413		H.T.		10/4/06		±5'	
				dr		10/16/06			
				enrg		10/16/06			
				chr		10/12/06			
				appd		10/12/06			
sheet index		revision sheet		C		1		title	
								1mm SPACING SMT CONNECTOR (Cat.No. HFW__R-1STE1LF)	
								dwg no sheet 1 of 1 size	
								JSA 95927 A4	
								type Product Customer Drawing	
sheet index		revision sheet		C		1		Rev. C	

SC-HFWR02 JSA95926 form: A4

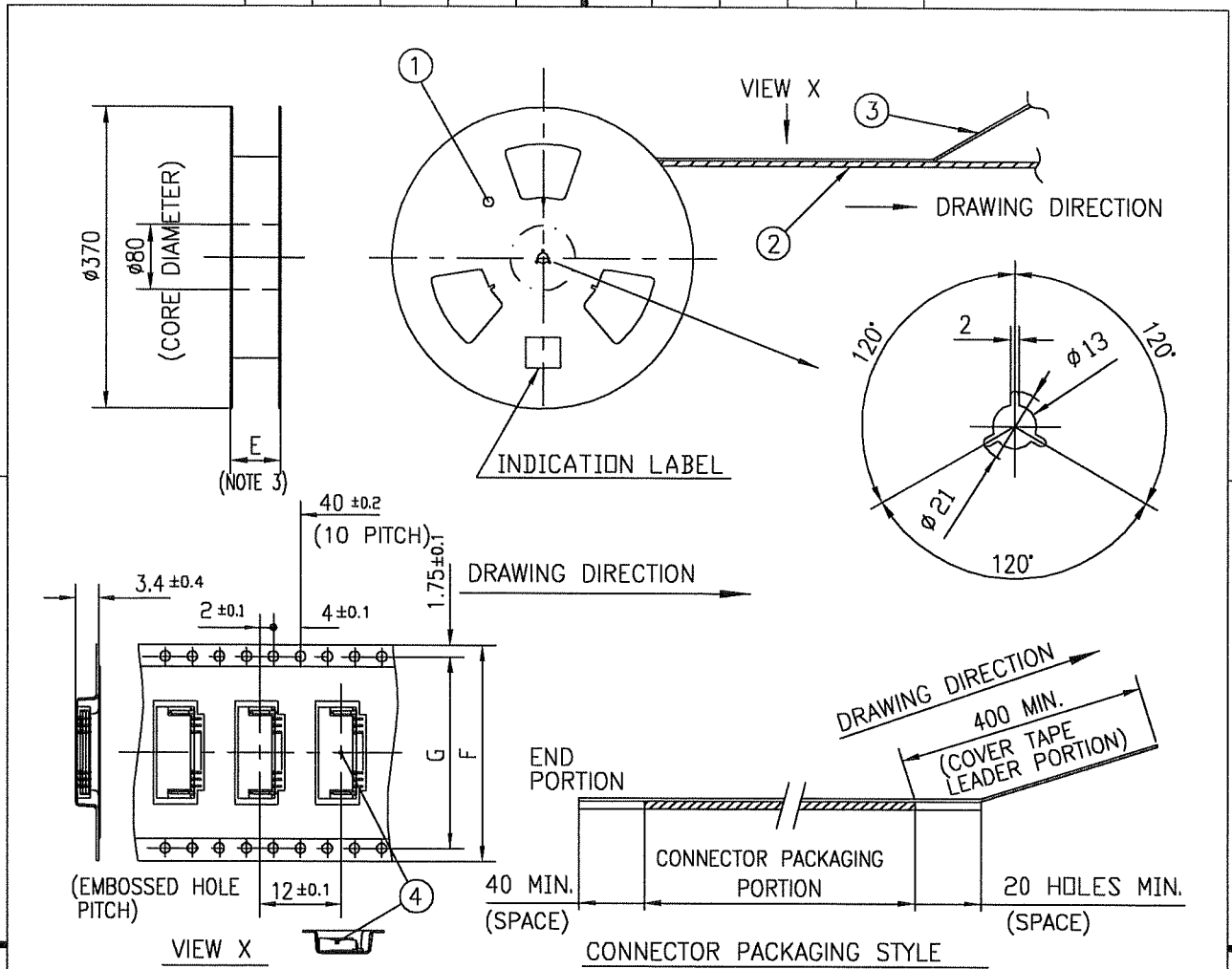

PT. NO.	PARTS NAME	CAT. NO.	MATERIAL	Q'TY	NOTE
1	REEL	---	CARDBOARD	1	COLOR:WHITE
2	PLASTIC (EMBOSSD) TAPE	---	PET	---	COLOR:TRANSPARENCY
3	COVER	---	POLYESTER	---	COLOR:TRANSPARENCY
4	CONNECTOR	HFW__R-2ST__-LF	SEE ATTACHED DWG.	2000	UPPER CONTACT TYPE

NOTES

1. THIS IS PLASTIC TAPE PACKAGED CONNECTOR DESIGNED TO TERMINATE FPC/FFC AND COPES WITH AUTOMATIC MOUNTING (SMT).
2. SEE JIS C 0806 (PACKING OF ELECTRONIC COMPONENTS ON CONTINUOUS TAPES (SURFACE MOUNTING DEVICES)) FOR SHAPE AND DIMENSIONS OF PLASTIC (EMBOSSD) TAPE AND REEL.
3. E DIMENSION IS PORTION OF THE CORE.

mat'l. code		surface 58/ISO 1302 ✓		tolerance ISO 406 ISO 1101		projection		product family 58NF		CODE JP	
ltr		ecn no		dr		date		tolerances unless otherwise specified		title	
A		J04-0027		H.T		4/6/'04		±5		1mm SPACING SMT CONNECTOR	
B		J05-0056		H.T		2/4/'05		mm		(Cat.No. HFW__R-2STE1LF)	
C		J06-0413		H.T		10/4/'06		scale X		dwg no	
								FCJ		sheet 1 of 1	
										JSA 95928	
										size A4	
										type Product Customer Drawing	
sheet index		revision sheet		C		1				Rev. C	

SC-HFWR02 JSA95926 form: A4

RECOMMENDED CABLE (FPC)

n : NO. OF CONDUCTORS

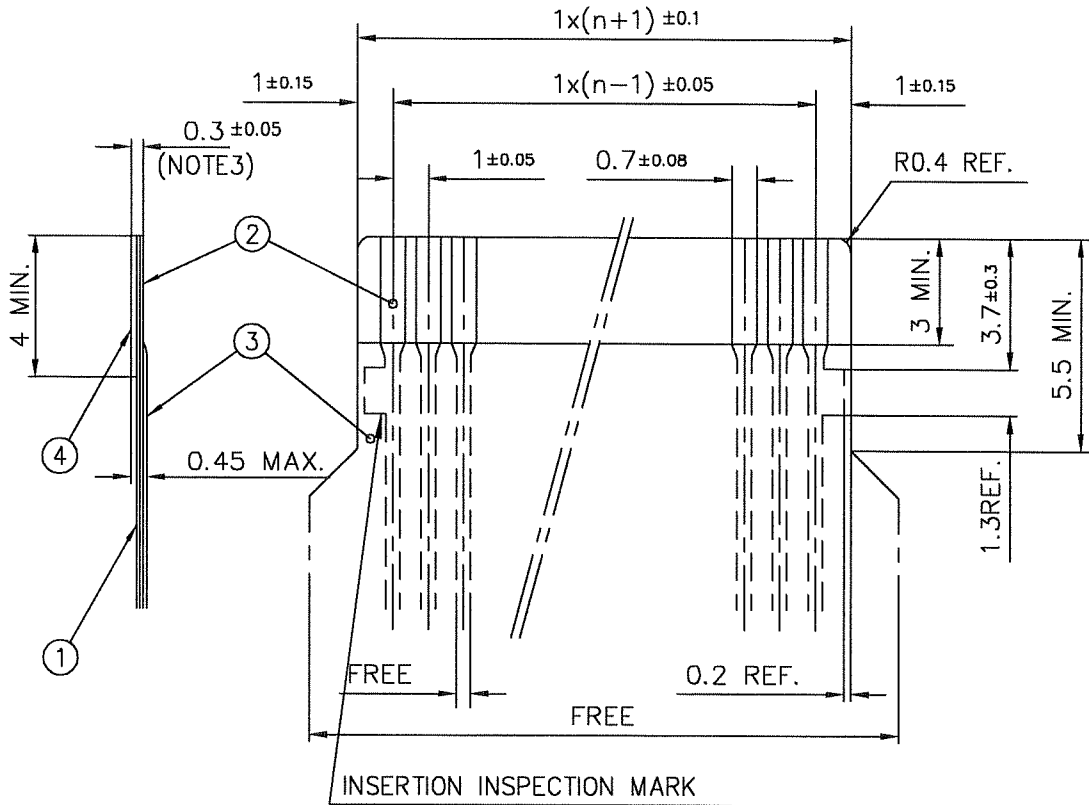

PT. NO.	DESCRIPTION	MATERIAL	THICKNESS ( $\mu\text{m}$ )
1	BASE FILM	POLYIMIDE OR POLYESTER OR EQUIVALENT	25
2	CONDUCTOR	COPPER FOIL(PLATING : SOLDER $1\mu\text{m}$ MIN.)	35
3	OVERLAY	POLYIMIDE OR POLYESTER OR EQUIVALENT	—
4	SUPPORTING TAPE	POLYESTER OR POLYIMIDE OR EQUIVALENT	188

NOTES

1. NO BURR AT EACH PORTION.
2. NO PEELING IN COMMON USE.
3. TOTAL THICKNESS LIMIT OF EACH MATERIAL (INCLUDING ADHESIVE AGENT) IS SPECIFIED.

mat'l. code				surface 58 / tolerance ISO 1302 ✓ ISO 406 ISO 1101		projection		product family 58NF		CODE JP		
ltr	ecn no	dr	date	tolerances unless otherwise specified				title				
A	J06-0413	H.T	10/4/'06	angles linear				RECOMMENDED CABLE (Cat. No. HFW__R-1/2__)				
				mm				scale $\times$				
				dr <i>H. Saito</i> 10/14/'06				dwg no		sheet 1 of 1		size
				enr <i>H. Saito</i> 10/15/'06				JSA 93573				A4
				chr <i>J.B.</i> 10/12/'06				type		Product Customer Drawing		
				app <i>S. Miedama</i> 10/12/'06								
sheet index	revision	A	1									Rev. A

form: A4

1

2



RECOMMENDED CABLE (FFC)

n : NO. OF CONDUCTORS

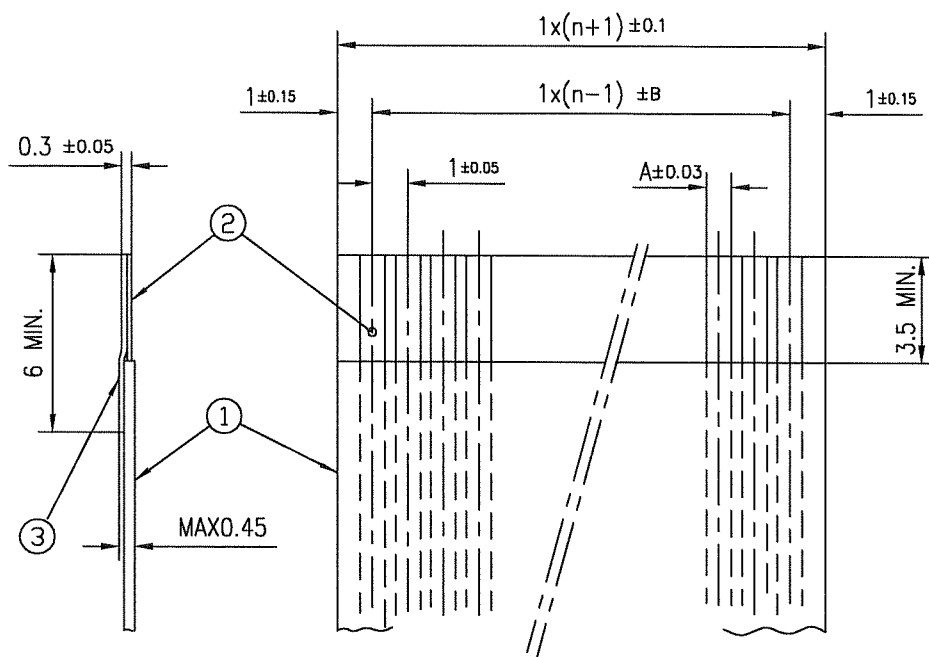

(NOTE 3)	DIMENSION A	TOLERANCE B
1	0.7	0.1
2	0.6	0.07

PT. NO.	DESCRIPTION	MATERIAL	NOTE
1	INSULATOR	FLAME RESISTING POLYESTER OR EQUIVALENT	_____
2	CONDUCTOR	COPPER FOIL	PLATING: TIN OR SOLDER 1µm MIN.
3	SUPPORTING TAPE	FLAME RESISTING POLYESTER OR EQUIVALENT	_____

NOTES

1. NO BURR AT EACH PORTION.
2. NO PEELING IN COMMON USE.
3. BOTH COMBINATION IS ALLOWED.

mat'l. code				surface 58 / tolerance ISO 1302 ✓ / ISO 406 / ISO 1101		projection		product family 58NF		CODE JP	
ltr				ecn no		dr		date		tolerances unless otherwise specified	
1				---		T.M		4/30/'02		angles linear	
A				J06-0413		H.T		10/4/'06		mm	
										scale X	
				dr		engr		chr		appd	
				/ 10/12/06		/ 10/12/06		/ 10/12/06		/ 10/12/06	
				/ 10/12/06		/ 10/12/06		/ 10/12/06		/ 10/12/06	
				/ 10/12/06		/ 10/12/06		/ 10/12/06		/ 10/12/06	
sheet index				revision sheet		A		1		Rev. A	



FCIconnect.com

Copyright FCI.





Компания «ЭлектроПласт» предлагает заключение долгосрочных отношений при поставках импортных электронных компонентов на взаимовыгодных условиях!

Наши преимущества:

- Оперативные поставки широкого спектра электронных компонентов отечественного и импортного производства напрямую от производителей и с крупнейших мировых складов;
- Поставка более 17-ти миллионов наименований электронных компонентов;
- Поставка сложных, дефицитных, либо снятых с производства позиций;
- Оперативные сроки поставки под заказ (от 5 рабочих дней);
- Экспресс доставка в любую точку России;
- Техническая поддержка проекта, помощь в подборе аналогов, поставка прототипов;
- Система менеджмента качества сертифицирована по Международному стандарту ISO 9001;
- Лицензия ФСБ на осуществление работ с использованием сведений, составляющих государственную тайну;
- Поставка специализированных компонентов (Xilinx, Altera, Analog Devices, Intersil, Interpoint, Microsemi, Aeroflex, Peregrine, Syfer, Eurofarad, Texas Instrument, Miteq, Cobham, E2V, MA-COM, Hittite, Mini-Circuits, General Dynamics и др.);

Помимо этого, одним из направлений компании «ЭлектроПласт» является направление «Источники питания». Мы предлагаем Вам помощь Конструкторского отдела:

- Подбор оптимального решения, техническое обоснование при выборе компонента;
- Подбор аналогов;
- Консультации по применению компонента;
- Поставка образцов и прототипов;
- Техническая поддержка проекта;
- Защита от снятия компонента с производства.



#### Как с нами связаться

**Телефон:** 8 (812) 309 58 32 (многоканальный)

**Факс:** 8 (812) 320-02-42

**Электронная почта:** [org@eplast1.ru](mailto:org@eplast1.ru)

**Адрес:** 198099, г. Санкт-Петербург, ул. Калинина, дом 2, корпус 4, литера А.