Single-Chip SIGFOX RF Transmitter

DATASHEET

Features

- Fully integrated, single-chip RF transmitter (SIGFOX™ compliant)
- System-on-chip solution including SIGFOX related protocol handling for modem operation
- AVR® microcontroller core with embedded firmware, SIGFOX, protocol stack and ID/PAC
- Supports uplink operation, i.e. transmit data telegram to SIGFOX base stations
- Operating frequency range: 868.0MHz to 868.6MHz
- Low current consumption: 32.7mA during telegram transmit with +14.5dBm TX output power
- Typical OFF mode current: 5nA (maximum 600nA at $V_S = +3.6V$ and $T = +85^\circ C$)
- Data rate: 100bit/s with DBPSK modulation
- SPI interface for TX data access and transmitter configuration
- Event signal indicates the status of the IC to an external microcontroller
- Power-up (typical 10ms OFF mode -> IDLE mode)
- Supply voltage ranges 1.9V to 3.6V and 2.4V to 5.5V (SIGFOX compliant supply range $3V \pm 5\%$ and 3.3V to 5.5V)
- Temperature range $-40^\circ C$ to $+85^\circ C$
- ESD protection at all pins ($\pm 4kV$ HBM, $\pm 200V$ MM, $\pm 750V$ FCDM)
- Small 5×5mm QFN32 package/pitch 0.5mm

Applications

SIGFOX compatible modem for long-range, low-power and low-cost applications using the SIGFOX network

- Home and building automation
- Alarm and security systems
- Smart environment and industrial
- Smart parking
- Tracking
- Metering

1. General Description

1.1 Introduction

The Atmel® ATA8520 is a highly integrated, low-power RF transmitter with an integrated AVR® microcontroller for applications using the wide area SIGFOX™ network

The Atmel ATA8520 is partitioned into three sections: an RF front end, a digital baseband and the low-power 8-bit AVR microcontroller. The product is designed for the ISM frequency band in the range of 868.0MHz to 868.6MHz. The external part count is kept to a minimum due to the very high level of integration in this device. By combining outstanding RF performance with highly sophisticated baseband signal processing, robust wireless communication can be easily achieved. The transmit path uses a closed loop fractional-N modulator.

The SPI interface enables external control and device configuration.

1.2 System Overview

Figure 1-1. Circuit Overview

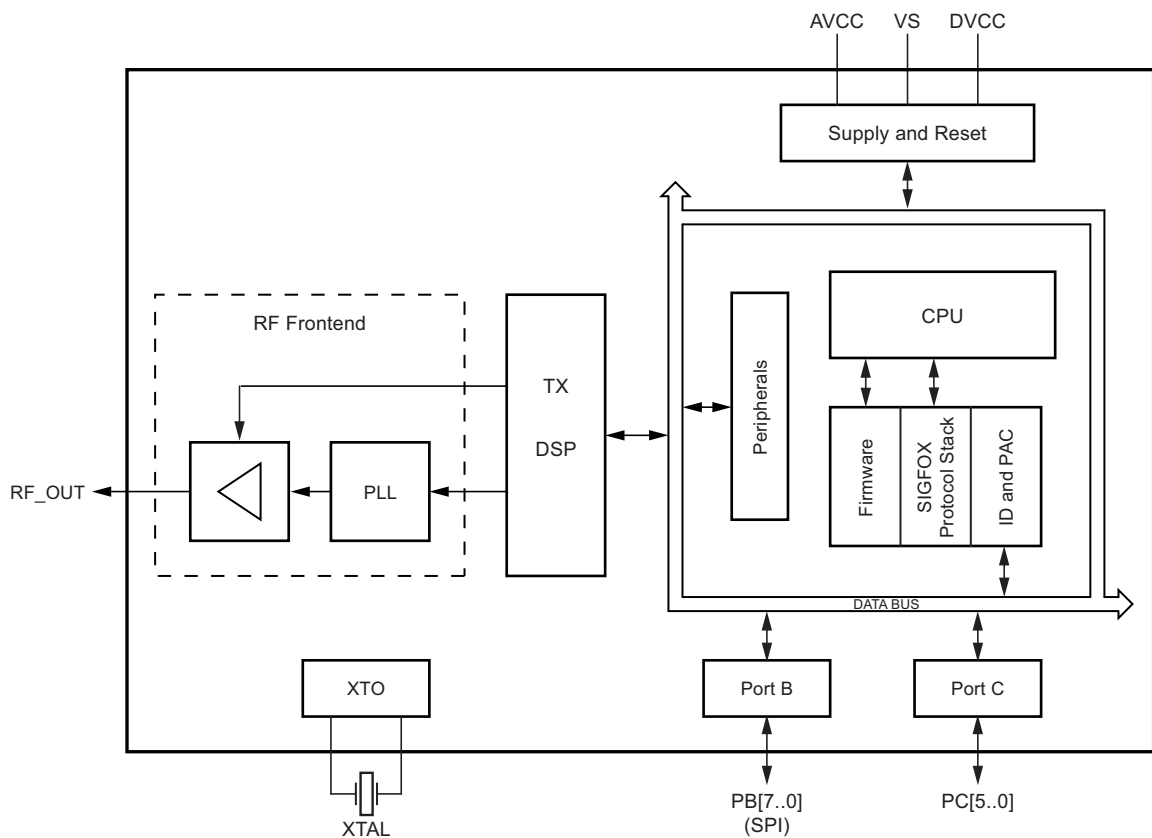

Figure 1-1 shows an overview of the main functional blocks of the Atmel ATA8520. External control of the Atmel ATA8520 is performed through the SPI pins SCK, MOSI, MISO, and NSS. The functionality of the device is defined by the internal firmware and processed by the AVR. SPI commands are used to control the device and to start the data telegram transmission. The end of the telegram transmission is signaled to an external microcontroller on pin 28 (PB6/EVENT).

It is important to note that all PWRON and NPWRON pins (PC1..5, PB4, PB7) are active in OFF mode. This means that even if the Atmel ATA8520 is in OFF mode and the DVCC voltage is switched off, the power management circuitry within the Atmel ATA8520 biases these pins with VS.

The AVR microcontroller ports can be used as button inputs, LED drivers, EVENT pin, general purpose digital inputs, or wake-up inputs, etc. Functionality of these ports is already implemented in the firmware.

1.3 Pinning

Figure 1-2. Pin Diagram

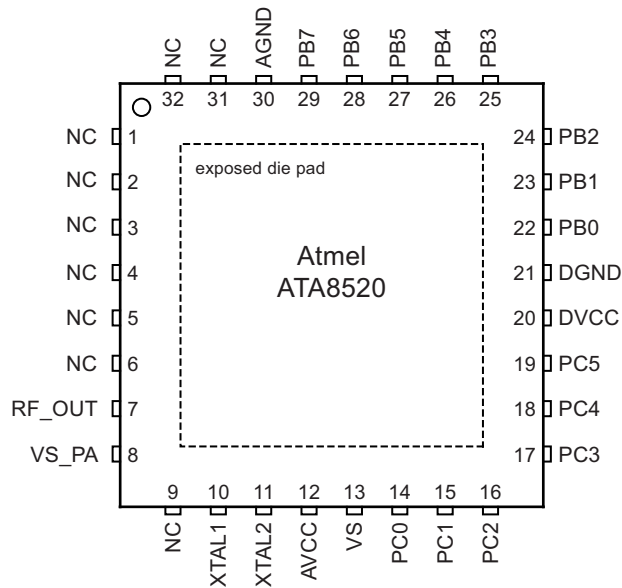

Note: The exposed die pad is connected to the internal die.

Table 1-1. Pin Description

Pin No.	Pin Name	Type	Description
1	NC		Connected to GND
2	NC		Connected to GND
3	NC		Connected to GND
4	NC		Connected to GND
5	NC		Leave open
6	NC		Connected to GND
7	RF_OUT	Analog	Power amplifier output
8	VS_PA	Analog	Power amplifier supply. 3V supply: connect to VS. 5V supply: leave open. Use SPI command "Write System Configuration" (0x11) to enable 5V supply mode
9	NC	–	Connected to GND
10	XTAL1	Analog	Crystal oscillator pin 1 (input)
11	XTAL2	Analog	Crystal oscillator pin 2 (output)
12	AVCC	Analog	RF front-end supply regulator output
13	VS	Analog	Main supply voltage input
14	PC0	Digital	Main : NRESET
15	PC1	Digital	Main : AVR Port C1 Alternate : NPWRON1
16	PC2	Digital	Main : AVR Port C2 Alternate : NPWRON2
17	PC3	Digital	Main : AVR Port C3 Alternate : NPWRON3

Table 1-1. Pin Description (Continued)

Pin No.	Pin Name	Type	Description
18	PC4	Digital	Main Alternate : AVR Port C4 : NPWRON4
19	PC5	Digital	Main Alternate : AVR Port C5 : NPWRON5
20	DVCC	–	Digital supply voltage regulator output
21	DGND	–	Digital ground
22	PB0	Digital	Main :--
23	PB1	Digital	Main : SCK
24	PB2	Digital	Main : MOSI (SPI master out Slave in)
25	PB3	Digital	Main : MISO (SPI master in Slave out)
26	PB4	Digital	Main : PWRON
27	PB5	Digital	Main : NSS
28	PB6	Digital	Main : EVENT
29	PB7	Digital	Main Alternate : TX active : NPWRON6
30	AGND	–	Analog ground
31	NC	–	Connected to GND
32	NC	–	Connected to GND
	GND	–	Ground/backplane on exposed die pad

1.4 Applications

This section provides application examples for the two supply modes for the Atmel® ATA8520 device. In addition the recommended PCB design and layout is described to achieve the SIGFOX™ certification.

1.4.1 3V Application Example

Figure 1-3. 3V Application with External Microcontroller

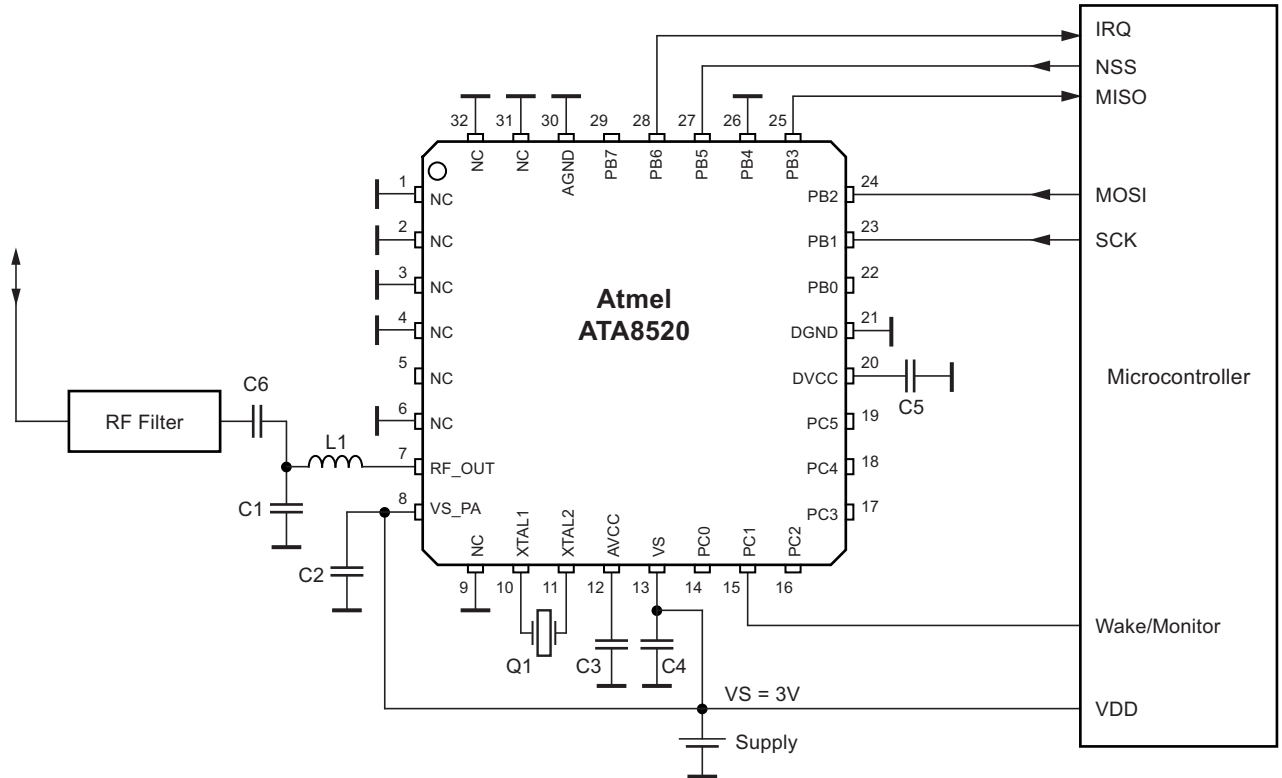

Figure 1-3 shows a typical application circuit with an external host microcontroller operating from a 3V lithium cell. The Atmel ATA8520 stays in OFFMode until NPWRON1 (PC1) is used to wake it up. In OFFMode the Atmel ATA8520 draws typically less than 5nA at 25°C.

In OFFMode all Atmel ATA8520 AVR® ports PB0..PB7 and PC0..PC5 are switched to input. PC0..PC5 and PB7 have internal pull-up resistors ensuring that the voltage at these ports is VS. PB0..PB6 are tri-state inputs and require additional consideration. PB1, PB2, and PB5 have defined voltages since they are connected to the output of the external microcontroller. PB4 is connected to ground to avoid unwanted power-ups. PB0, PB3 and PB6 do not require external circuitry since the internal circuit avoids transverse currents in OFFMode. The external microcontroller has to tolerate the floating inputs. Otherwise additional pull-down resistors are required on these floating lines.

Typically, the Atmel ATA8520 wake-up is done by pulling NPWRON1 (pin 15) to ground.

RF_OUT is matched with C1/L1 for 50Ω antenna connection. The RF filter is required to suppress unwanted side and spurious emissions. The design of this filter depends on the final PCB and system layout and is subject to SIGFOX and ETSI certification procedures.

Together with the fractional-N PLL within the Atmel ATA8520, an external crystal is used to fix the Tx frequency. Accurate load capacitors for this crystal are integrated to reduce the system part count and cost. Only four supply blocking capacitors are needed to decouple the different supply voltages AVCC, DVCC, VS, and VS_PA of the Atmel ATA8520. The exposed die pad is the RF and analog ground of the Atmel ATA8520. It is connected directly to AGND via a fused lead. The Atmel ATA8520 is controlled using specific SPI commands via the SPI interface.

2. System Functional Description

2.1 SPI Command Interface

The SPI command interface requires a timing setup as described in the following section and provides a set of commands to control the operation of the Atmel® ATA8520 device. The SPI transmission occurs with MSB first.

2.1.1 SPI Timing

The SPI communication requires a special timing to prevent data corruption. The SPI peripheral uses a SCK frequency of 125kHz for the bit transmission and requires timing delays between the CS signals and the start and stop of the SPI communication as shown in Figure 2-1.

Figure 2-1. SPI Timing Parameters

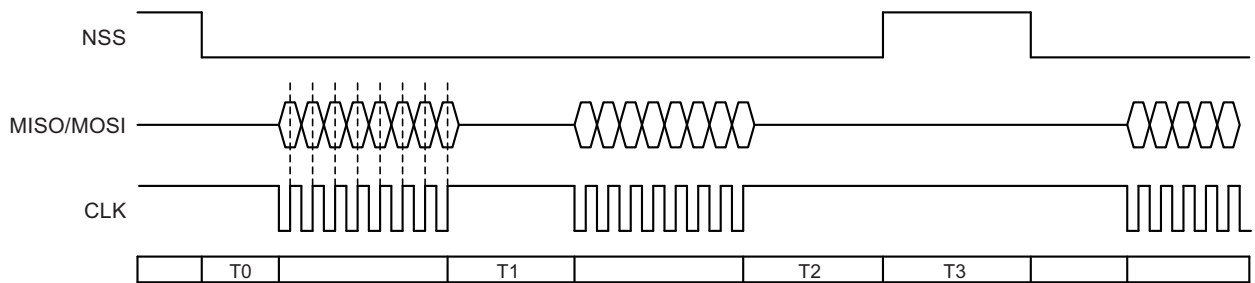

$T0 \geq 65\mu\text{s}$, $T1 \geq 40\mu\text{s}$, $T2 \geq 100\mu\text{s}$, $T3 \geq 50\mu\text{s}$, SPI CLK $\leq 125\text{kHz}$ (SPI Mode 0: CPOL = CPHA = 0)

2.1.2 SPI Command Set

The following SPI commands are available to control the ATA8520 operation from a host microcontroller.

2.1.2.1 System Reset

This command uses the system internal WDT to do a complete hardware reset of the ATA8520D. Resetting the device takes ~10ms. Afterwards the system restarts and generates an event on the EVENT signal after ~10ms. This event will be cleared with the “Get Status” SPI command (0x0A).

Master	System Reset (0x01)
ATA8520	Dummy

2.1.2.2 I/O Init

The I/O lines of port C can be used as additional I/O lines for an application. The port C I/O Init command defines the internal data direction register of output port PORTC (DDRC). Pin PC0 is used as NRESET signal and will always be an input pin, i.e. bit 0 will be written as 0 to be an input pin.

Master	I/O Init (0x02)	DDRC content
ATA8520	Dummy	Dummy

2.1.2.3 I/O Write

The I/O write command writes directly to the output port register PORTC to set the I/O pins. Pin PC0 is used as NRESET signal and will always be an input pin with enabled pull-up, i.e. bit 0 will be written as 1 to enable the internal pull-up resistor.

Master	I/O Init (0x03)	PORTC content
ATA8520	Dummy	Dummy

2.1.2.4 I/O Read

The I/O read command reads the status of the I/O pins directly from the input port register PINC. Pin PC0 is used as NRESET signal and will always be read as 1.

Master	I/O Read (0x04)	Dummy	Dummy
ATA8520	Dummy	Dummy	PINC content

2.1.2.5 OFF Mode

The OFF mode command puts the ATA8520 into off mode. To wake up the ATA8520 device, one of the power on lines has to be activated, i.e. set PWRON line to high or NPWRONx line to low. To switch the device into OFF mode the power on lines have to be de-activated before otherwise the device will remain in the on state.

Master	OFF Mode (0x05)
ATA8520	Dummy

2.1.2.6 Atmel Version

The Atmel version command reads the version information including a major and a minor version number.

Master	Atmel Version (0x06)	Dummy	Dummy	Dummy
ATA8520	Dummy	Dummy	MajorVers	MinorVers

2.1.2.7 Write TX Buffer

The write TX buffer command fills the TX buffer to be sent with the next SIGFOX™ data frame with payload data of up to 12 bytes. The buffer can hold any number of bytes ranging from 0 to 12 bytes and are not buffered, i.e. a new SPI command will override the previous data.

Master	Write TX Buffer (0x07)	RF TX Num bytes	RF TX Bytes 0	RF TX Num bytes-1
ATA8520	Dummy	Dummy	Dummy		Dummy

2.1.2.8 Test Mode (for Atmel Version <V1.0)

The test mode command triggers the SIGFOX defined test procedure to generate a test signal with frame (high, low byte): Number of frames to be send. Each frame is send 3 times [0...32768, -1 for infinite]. Chain (high, low Byte): Channel number used for transmission [0...480, -1 for hopping].

Master	Test Mode (0x08)	FrameLowByte	FramHighByte	ChanLowByte	ChanHighByte
ATA8520	Dummy	Dummy	Dummy	Dummy	Dummy

Note: This command will change in next generation devices.

2.1.2.9 SIGFOX Version

The SIGFOX version reads the SIGFOX library version information as a text string with N = 11 characters.

Master	SIGFOX Version (0x09)	Dummy	Dummy	Dummy
ATA8520	Dummy	Dummy	SFX Verinfo[0]		SFX Verinfo[N]

2.1.2.10 Get Status

The get status command reads the internal status of the device. Issuing this command clears the systems event line (PB6) and the status bytes. The event line is set to low when:

- a. System is ready after power-up or reset
- b. finishes the transmit operation
- c. finishes a temperature and supply measurement
- d. finishes the EEPROM write operation.

The following status information is read after the event line is activated, i.e. polling using the Get Status command is not necessary:

Hardware SSM status

Atmel® status:

- Bit6: System ready to operate (system ready event)
- Bit5: Frame sent (frame ready event)
- Bit4 to Bit1: Error code
 - 0000: no error
 - 0001: command error / not supported
 - 0010: generic error
 - 0011: frequency error
 - 0100: usage error
 - 0101: opening error
 - 0110: closing error
 - 0111: send error
- Bit0: PA on/off indication

SIGFOX™ status:

- 0x00: No error
- 0x01: Manufacturer error
- 0x02: ID or key error
- 0x03: State machine error
- 0x04: Frame size error
- 0x05: Manufacturer send error
- 0x06: Get voltage/temperature error
- 0x07: Close issues encountered
- 0x08: API error indication
- 0x09: Error getting PN9
- 0x0A: Error getting frequency
- 0x0B: Error building frame
- 0x0C: Error in delay routine
- 0x0D: callback causes error
- 0x0E: timing error
- 0x0F: frequency error

Master	Get Status (0x0A)	Dummy	Dummy	Dummy	Dummy
ATA8520	Dummy	Dummy	SSM status	Atmel status	SIGFOX status

2.1.2.11 Send Data Bit

This command sends a data bit (0/1) within a SIGFOX™ RF frame as specified by SIGFOX. An event on the EVENT signal is generated when finished.

Master	Send Bit (0x0B)	Bit
ATA8520	Dummy	Dummy

2.1.2.12 Send Frame

The send frame command triggers the start of a frame transmit process. The payload data has to be written into the TX buffer before using the write TX buffer command. The transmit operation will take ~7 seconds and will generate an event on the EVENT signal when finished. For Atmel® version ≥1.0 pin PB7 is switched to logic “1” during transmit operation which can be used to control an external power amplifier.

Master	Send Frame (0x0D)
ATA8520	Dummy

2.1.2.13 Get PAC

The get PAC command will read the 16 byte PAC information which is used for the device registration process at the SIGFOX backend. Only the 8 lower bytes (0) .. (7) are used, the remaining 8 upper bytes (8) .. (15) are read as 0.

Master	Get PAC (0x0F)	Dummy	Dummy	Dummy
ATA8520	Dummy	Dummy	PAC ID[0]		PAC ID[15]

2.1.2.14 Write System Configuration

The Write System Configuration command writes the configuration data for the port C and the system configuration into the internal EEPROM. This changes will be applied by performing a system reset. An event on the EVENT signal is generated when finished. DDRC register defines the data direction for the port C pins (0: input, 1: output). PORTC register defines the output level for an output pin and enables a pull-up resistor for input pins when set. SysConf has to be set to 0xFF for 3V supply mode and 0xF7 for 5V supply mode.

5V supply mode can only be used when this command was send before, otherwise the device may be damaged.

Master	Write Sys Conf (0x11)	DDRC	PORTC	0x02	SysConf
ATA8520D	Dummy	Dummy	Dummy	Dummy	Dummy

2.1.2.15 Get ID

The get ID command will read the 4 byte ID information which is used for the device registration process at the SIGFOX backend.

Master	Get ID (0x12)	Dummy	Dummy	Dummy
ATA8520	Dummy	Dummy	UID[3]		UID[0]

2.1.2.16 Read Supply Voltage and Temperature

This command triggers the read out of the measured supply voltage in idle and active mode and the device temperature. To trigger a measurement the SPI command (0x14) has to be used. The return voltage level is in mV and the temperature value has to be calculated as $T = (TM - 500)/10$ in °C. All values are of type 16 bit unsigned integer (with high and low byte).

Master	Read Sup/Temp (0x13)	Dummy	Dummy	Dummy	Dummy	Dummy	Dummy	Dummy
ATA8520	Dummy	Dummy	VHidle	VLidle	VHactive	VLactive	TemperatureH	TemperatureL

2.1.2.17 Start Supply and Temperature Measurement

This command will start the measurement of the temperature and the supply voltage. An event on the EVENT signal is generated when finished.

Master	Start Measurement (0x14)
ATA8520	Dummy

2.1.2.18 Start TX Test Mode

The test mode command triggers the SIGFOX™ defined test procedure to generate a test signal with frame (high, low byte): Number of frames to be send. Each frame is send 3 times [0...32768, -1 for infinite]. Chain (high, low Byte): Channel number used for transmission [0...480, -1 to deactivate hopping]. An event on the EVENT signal is generated when finished.

Master	TX Test Mode (0x15)	FrameLowByte	FramHighByte	ChanLowByte	ChanHighByte
ATA8520	Dummy	Dummy	Dummy	Dummy	Dummy

2.1.2.19 Send CW

The test mode command enables or disables the transmission of a continuous carrier (CW) as defined by SIGFOX.

Master	Send CW (0x17)	On(0x11)/Off(0x00)
ATA8520	Dummy	Dummy

2.1.2.20 Set TX Frequency

Set TX center frequency temporarily for testing purposes. This settings are lost after reset or when switching the device off. The frequency value is an unsigned 32-bit integer within the range [868.000.000Hz to 868.600.000Hz]. Default is 868.130.000Hz.

Master	Set TX Frequency (0x1B)	TX[31:24]	TX[23:16]	TX[15:8]	TX[7:0]
ATA8520	Dummy	Dummy	Dummy	Dummy	Dummy

2.1.3 Command Table Overview

Table 2-1. Command Table Overview

CMD	Index	Write Data	Read Data
System reset	0x01	None	None
I/O Init	0x02	DDRC register setting	None
I/O Write	0x03	PORTC register setting	None
I/O Read	0x04	None	PINC register setting
OFF mode	0x05	None	None
Atmel version	0x06	None	Major / minor
Write TX buffer	0x07	Data written to TX buffer	None
Test mode (<V1.0)	0x08	Frame/channel	None
Reserved (≥V1.0)		-	-
SIGFOX™ version	0x09	None	Version L-H
Get status	0x0A	None	SSM / Atmel® FW / SIGFOX library
Send bit	0x0B ⁽¹⁾	Bit (0/1)	None
Reserved	0x0C	-	-
Send frame	0x0D	None	None
Reserved	0x0E	-	-
Get PAC	0x0F	None	PAC[0], PAC[1] PAC[15]
Reserved	0x10	-	-
Write Sys Conf	0x11 ⁽¹⁾	DDRC, PORTC, SysConf	None
Get ID	0x12	None	ID[3] ... ID[0]
Read sup/temp	0x13 ⁽¹⁾	None	Supply idle / supply active / temperature
Start measurement	0x14 ⁽¹⁾	None	None
TX test mode	0x15 ⁽¹⁾	Frame/channel	None
Reserved	0x16	-	-
Send CW	0x17 ⁽¹⁾	On/Off	None
Reserved	0x18	-	-
Reserved	0x19	-	-
Reserved	0x1A	-	-
Set TX frequency	0x1B ⁽¹⁾	TX frequency	None
Reserved	0x1C	-	-

Note: 1. These commands are available in device with Atmel Version V ≥ 1.0

2.2 Operating Modes Overview

This section gives an overview of the operating modes supported by the Atmel ATA8520.

After connecting the supply voltage to the VS pin, the Atmel ATA8520 always starts in OFF mode. All internal circuits are disconnected from the power supply. Therefore, no SPI communication is supported. The Atmel ATA8520 can be woken up by activating the PWRON pin or one of the NPWRONx pins. This triggers the power-on sequence which will set the event line PB6 to low. After the system initialization the Atmel ATA8520 reaches the IDLE Mode.

The IDLE Mode is the basic system mode supporting SPI communication and transitions to the other operating modes. The transmit mode (TX Mode) starts the data transmission using the payload data which has to be previously written into the TX buffer with the SPI command “Write TX Buffer”. The data transmission is started with the SPI command “Send Frame”. After transmitting the data frame, the end of the transmission is indicated when the event pin PB6 switches to low and the device enters the IDLE Mode again. Reading the device status with the “Get Status” SPI command clears the PB6 event line, setting it to high level again.

2.2.1 System Configuration

This section specifies the system configuration settings used in the SPI command (0x11). This system configuration has to be set after the system issues a system ready event and before using any other SPI RF transmit command. The settings are stored in the internal EEPROM and will be applied after a system reset. This settings are typically applied at the EOL testing in the factory. [Table 2-2](#) summarizes the configuration settings.

Table 2-2. System Configuration

Function	Bit No.	Settings
None	7 to 4	:1111 (default)
Supply voltage	3	:0, 5V supply :1, 3V supply (default)
None	2 to 0	:111 (default)

Caution: The device is delivered with default configuration, i.e. with 3V supply mode enabled. When using the device with 5V supply it has to be ensured that before using the RF transmit operation the 5V supply mode is configured!

2.2.2 Power-up Sequence

This section describes the power-up sequence for the device as described in [Figure 2-2](#). The device is usually in OFF mode were the signals NPWRONx, PWRON and NRESET are inactive but VS is supplied with power. Switching the NRESET signal active or sending the SPI command System Reset (0x01) will have no effect in OFF mode. Switching one of the power-on pins active will wake-up the device and an internal power-on reset is performed. In addition the external NRESET line can be used to keep the device in reset state when waking-up the device. The minimum activation time for the NPWRONx, PWRON and NRESET signals is 10µs.

Figure 2-2. Power-up Sequence

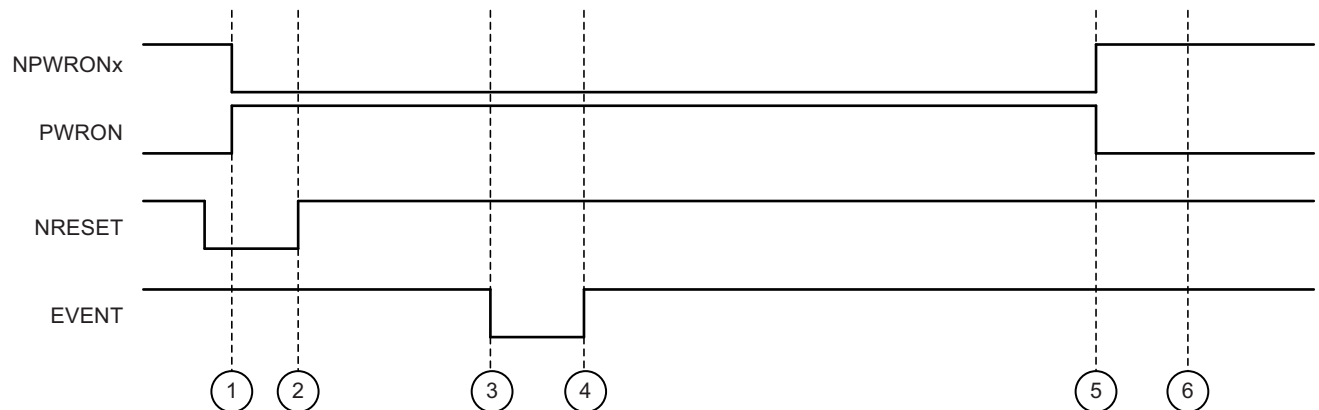

After applying the reset signal NRESET one of the power-up signals NPWRON1...6 or PWRON is applied at timing point T1. At timing point T2 (~10µs after T1) the external reset signal is removed and the device starts its internal power-up sequence. This internal sequence is finished at timing point T3 (~10ms after T2) and is signaled with the event line. Reading the device status with the SPI command (0x0A) „Get status” will clear the event line at timing point T4. The device is now in idle mode and operational even if the NPWRONx and PWRON signals are deactivated.

To shutdown the device into OFF mode the power-up signals NPWRON1...6 or PWRON have to be deactivated at first (shown in timing point T5). The shutdown into OFF mode is then performed by sending the SPI command (0x05) „OFF mode” to the device.

2.2.3 Application Example

The software to control the device and to transmit a data frame has to perform the following steps:

1. Initialize device as shown in [Figure 2-2](#) for the power-up sequence
2. Check for the startup event and read the device status with SPI command (0x0A) „Get status” to clear this event
3. Load the transmit buffer with up to 12 bytes using the SPI command (0x07) „Write TX Buffer”
4. Start the data transmit with SPI command (0x0D) „Send Frame”
5. Wait until the event signal appears (this takes about 7-8 seconds)
6. Read the device status with SPI command (0x0A) „Get status” to clear this event
7. Switch off the power-on signals as shown in [Figure 2-2](#)
8. Send the SPI command (0x05) „OFF mode” to the shutdown the device

For the SPI communication it is important to keep the timing as shown in [Figure 2-1 on page 7](#). With the SPI commands (0x0F) „Get PAC” and (0x12) „Get ID” the SIGFOX™ registration information can be read to register the device in the SIGFOX cloud.

3. Electrical Characteristics

3.1 ESD Protection Circuits

GND is the exposed die pad of the Atmel® which is internally connected to AGND (pin 30). All Zener diodes shown in [Figure 3-1](#) (marked as power clamps) are realized with dynamic clamping circuits and not physical Zener diodes. Therefore, DC currents are not clamped to the shown voltages.

Figure 3-1. Atmel ESD Protection Circuit

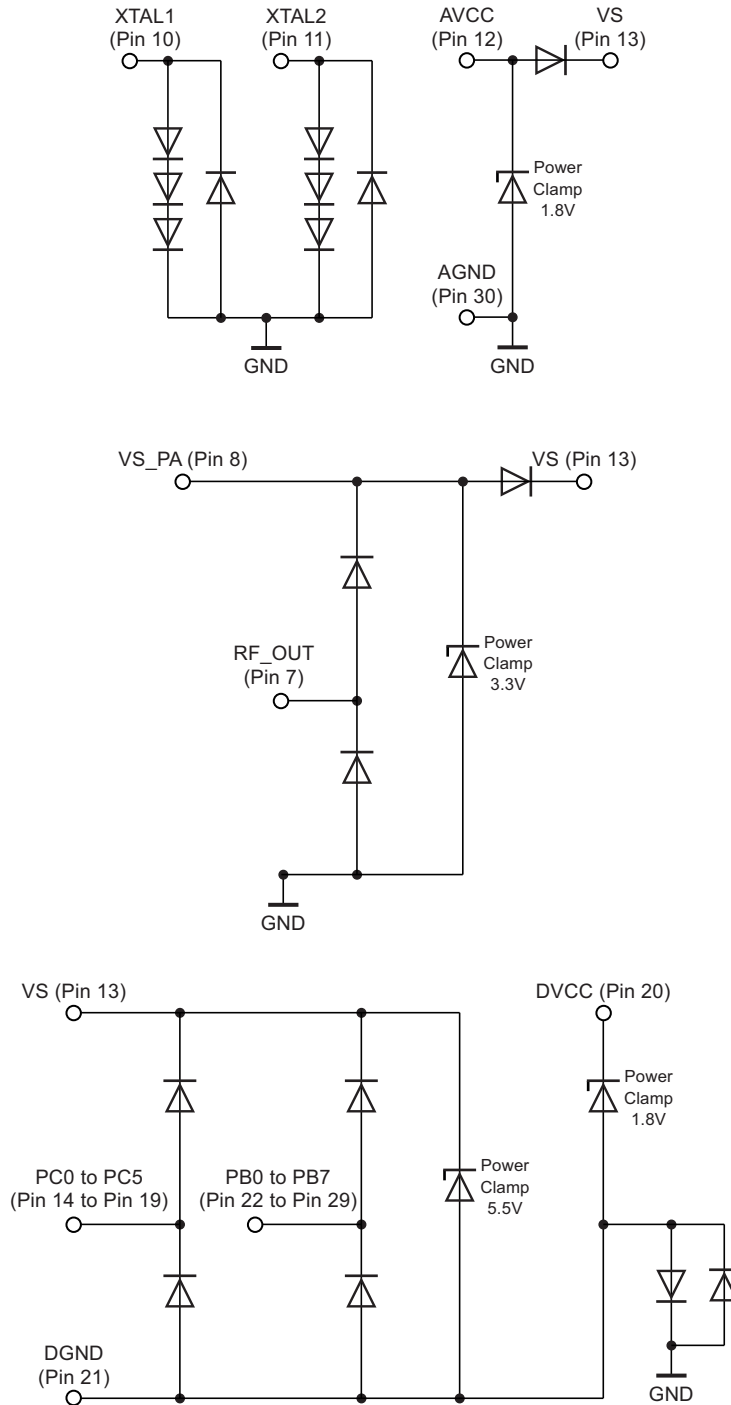

3.2 Absolute Maximum Ratings

Stresses beyond those listed under “Absolute Maximum Ratings” may cause permanent damage to the device. This is a stress rating only and functional operation of the device at these or any other conditions beyond those indicated in the operational sections of this specification is not implied. Exposure to absolute maximum rating conditions for extended periods may affect device reliability.

Parameters	Symbol	Min.	Max.	Unit
Junction temperature	T _j		+150	°C
Storage temperature	T _{stg}	-55	+125	°C
Ambient temperature	T _{amb}	-40	+85	°C
Supply voltage	V _{VS}	-0.3	+6.0	V
Supply voltage PA (1.9 to 3.6V application)	V _{VS_PA}	-0.3	+4.0	V
ESD (human body model) all pins	HBM	-4	+4	kV
ESD (machine model) all pins	MM	-200	+200	V
ESD (field induced charged device model) all pins	FCDM	-750	+750	V

3.3 Thermal Resistance

Parameters	Symbol	Value	Unit
Thermal resistance, junction ambient, soldered in compliance with JEDEC	R _{th_JA}	35	K/W

3.4 Supply Voltages and Current Consumption

All parameters refer to GND (backplane) and are valid for T_{amb} = -40°C to +85°C, V_{VS} = 1.9V to 3.6V across all process tolerances unless otherwise specified. Typical values are given at V_{VS} = 3V, T_{amb} = 25°C, and for a typical process unless otherwise specified. Crystal oscillator frequency f_{XTO} = 24.305MHz.

No.	Parameters	Test Conditions	Pin	Symbol	Min.	Typ.	Max.	Unit	Type*
1.00	Supply voltage range VS	3V application	13	V _{VS}	1.9	3.0	3.6	V	A
		5V application	13	V _{VS}	2.4	5.0	5.5	V	A
1.01	Supply voltage for SIGFOX™ compliance	3V application	13	V _{VS}	2.9	3.0	3.1	V	
		5V application	13	V _{VS}	3.3	5.0	5.5	V	
1.05	Supply voltage rise time		13	V _{VS_rise}			1	V/μs	D
1.10	Supply voltage range VS_PA	3V application	8	V _{VS_PA}	1.9	3	3.6	V	A
		5V application	8	V _{VS_PA}		3		V	A
		SIGFOX compliant	8	V _{VS_PA}		3		V	
1.20	OFF mode Current consumption	T _{amb} = 25°C T _{amb} = 85°C	8, 13	I _{OFFMode_3V}		5	150 600	nA nA	B B
1.30	Idle Mode current consumption	Temperature range -40°C to +65°C	13	I _{IdleMode}		50	90	μA	B

*) Type means: A = 100% tested, B = 100% correlation tested, C = characterized on samples, D = design parameter
Pin numbers in brackets mean they are measured matched to 50Ω on the application board.

3.4 Supply Voltages and Current Consumption (Continued)

All parameters refer to GND (backplane) and are valid for $T_{amb} = -40^{\circ}\text{C}$ to $+85^{\circ}\text{C}$, $V_{VS} = 1.9\text{V}$ to 3.6V across all process tolerances unless otherwise specified. Typical values are given at $V_{VS} = 3\text{V}$, $T_{amb} = 25^{\circ}\text{C}$, and for a typical process unless otherwise specified. Crystal oscillator frequency $f_{XTO} = 24.305\text{MHz}$.

No.	Parameters	Test Conditions	Pin	Symbol	Min.	Typ.	Max.	Unit	Type*
2.00	TX mode current consumption	$P_{out} = +14\text{dBm}$ $f_{RF} = 868.3\text{MHz}$	(7), 8, 13	I_{TXMode}		32.7	45	mA	B
2.05	SIGFOX™ TX mode current consumption	$T_{amb} = 25^{\circ}\text{C}$, 3V application	(7), 8, 13	$I_{SIGFOXMode}$		31.8	40.1	mA	B
2.06	SIGFOX TX mode current consumption	$T_{amb} = 85^{\circ}\text{C}$, 3V application	(7), 8, 13	$I_{SIGFOXMode}$		32.7	41.1	mA	B

*) Type means: A = 100% tested, B = 100% correlation tested, C = characterized on samples, D = design parameter
Pin numbers in brackets mean they are measured matched to 50Ω on the application board.

3.5 RF Transmit Characteristics

All parameters refer to GND (backplane) and are valid for $T_{amb} = -40^{\circ}\text{C}$ to $+85^{\circ}\text{C}$, $V_{VS} = 1.9\text{V}$ to 3.6V across all process tolerances unless otherwise specified. Typical values are given at $V_{VS} = 3\text{V}$, $T_{amb} = 25^{\circ}\text{C}$, and for a typical process unless otherwise specified. Crystal oscillator frequency $f_{XTO} = 24.305\text{MHz}$.

No.	Parameters	Test Conditions	Pin	Symbol	Min.	Typ.	Max.	Unit	Type*
10.00	Output power range	$T_{amb} = 25^{\circ}\text{C}$	(7)	P_{Range}			+14.5	dBm	B
10.01	Output power for SIGFOX compliance	$T_{amb} = 25^{\circ}\text{C}$, $V_{VS} = 2.9\text{V}$ to 3.1V, 3V application (for 5V applications see no. 11.50)	(7)	P_{SIGFOX}	13.5	13.8	14.0	dBm	B
10.02	Output power for SIGFOX compliance	$T_{amb} = -45^{\circ}\text{C}$ to $+85^{\circ}\text{C}$, $V_{VS} = 3.0\text{V}$, 3V application (for 5V applications see no. 11.50)	(7)	P_{SIGFOX}	13.1	13.8	14.7	dBm	B
10.05	Frequency range	Defined by SIGFOX protocol	(7)	f_{VCO}	868.0		868.6	MHz	
11.00	Output power at 14dBm	$T_{amb} = 25^{\circ}\text{C}$ using 14dBm matching	(7)	P_{out_14dBm}	-1.5dB	14	+1.5dB	dBm	B
11.10	Output 2 nd harmonic at 14dBm	$T_{amb} = 25^{\circ}\text{C}$ using 14dBm matching	(7)	$HM2_{14dBm}$		-24		dBc	C
11.20	Output 3 rd harmonic at 14dBm	$T_{amb} = 25^{\circ}\text{C}$ using 14dBm matching	(7)	$HM3_{14dBm}$		-50		dBc	C
11.50	Output power change full temperature and supply voltage range	For 13.8dBm $V_{VS_PA} = 3.0\text{V} \pm 0.3\text{V}$ $P = P_{out} + \Delta P$	(7)	$\Delta P_{TambVs2}$	-3.5		+2	dB	C C
11.60	Spurious emission	at $\pm f_{XTO}$ at $\pm f_{AVR} (f_{XTO} / 4)$ at $\pm f_{CLK_OUT} (f_{XTO} / 6)$	(7)	SP_{TX}		-72 -85 -78	-60 -60 -60	dBc	B C C

*) Type means: A = 100% tested, B = 100% correlation tested, C = characterized on samples, D = design parameter
Pin numbers in brackets mean they are measured matched to 50Ω on the application board.

3.6 RF Transmit Characteristics

All parameters refer to GND (backplane) and are valid for $T_{amb} = -40^{\circ}\text{C}$ to $+85^{\circ}\text{C}$, $V_{VS} = 1.9\text{V}$ to 3.6V over all process tolerances, quartz parameters $C_m = 4\text{fF}$ and $C_0 = 1\text{pF}$ unless otherwise specified. Typical values are given at $V_{VS} = 3\text{V}$, $T_{amb} = 25^{\circ}\text{C}$, and for a typical process unless otherwise specified. Crystal oscillator frequency $f_{XTO} = 24.305\text{MHz}$.

No.	Parameters	Test Conditions	Pin	Symbol	Min.	Typ.	Max.	Unit	Type*
13.30	XTO frequency range		10, 11	f_{xto}		24.305		MHz	C
13.35	XTO frequency for SIGFOX™ compliance	KDS: 1C324305AB0B NDK: NX3225SA EXS00A-CS08559 NX2016SA EXS00A-CS08560	10, 11	f_{SIGFOX_XTO}		24.305		MHz	
13.40	XTO pulling due to internal capacitance and XTO tolerance	$C_m = 4\text{fF}$, $T_{amb} = 25^{\circ}\text{C}$	10, 11	ΔF_{XTO1}	-10		+10	ppm	B
13.50	XTO pulling due to temperature and supply voltage	$C_m = 4\text{fF}$ $T_{amb} = -40^{\circ}\text{C}$ to $+85^{\circ}\text{C}$	10, 11	ΔF_{XTO2}	-4		+4	ppm	B
13.60	Maximum C_0 of XTAL	XTAL parameter	10, 11	C_{0_max}		1	2	pF	D
13.70	XTAL, C_m motional capacitance	XTAL parameter	10, 11	C_m		4	10	fF	D
13.80	XTAL, real part of XTO impedance at start-up	$C_m = 4\text{fF}$, $C_0 = 1\text{pF}$	10, 11	R_{m_start1}	950			Ω	B
13.90	XTAL, real part of XTO impedance at start-up	$C_m = 4\text{fF}$, $C_0 = 1\text{pF}$, $T_{amb} < 85^{\circ}\text{C}$	10, 11	R_{e_start2}	1100			Ω	B
14.00	XTAL, maximum R_m after start-up	XTAL parameter	10, 11	R_{m_max}	110			Ω	D
14.10	Internal load capacitors	Including ESD and package capacitance. XTAL has to be specified for 7.5pF load capacitance (incl. 1pF PCB capacitance per pin)	10, 11	C_{L1}, C_{L2}	13.3	14	14.7	pF	B

*) Type means: A = 100% tested, B = 100% correlation tested, C = characterized on samples, D = design parameter
Pin numbers in brackets mean they are measured matched to 50Ω on the application board.

3.7 I/O Characteristics for Ports PB0 to PB7 and PC0 to PC5

All parameters refer to GND (backplane) and are valid for $T_{amb} = -40^{\circ}\text{C}$ to $+85^{\circ}\text{C}$, $V_{VS} = 1.9\text{V}$ to 3.6V over all process tolerances unless otherwise specified. Typical values are given at $V_{VS} = 3\text{V}$, $T_{amb} = 25^{\circ}\text{C}$, and for a typical process unless otherwise specified. Crystal oscillator frequency $f_{XTO} = 24.305\text{MHz}$.

No.	Parameters	Test Conditions	Pin	Symbol	Min.	Typ.	Max.	Unit	Type*
15.00	Input low voltage	PC0 to PC5 PB0 to PB7	14-19 22-29	V_{IL}	-0.3		$0.2 \times V_{VS}$	V	A
15.05	Input low leakage current I/O pin	PC0 to PC5 PB0 to PB7	14-19 22-29	I_{IL}			-1	μA	A
15.10	Input high voltage	PC0 to PC5 PB0 to PB7	14-19 22-29	V_{IH}	$0.8 \times V_{VS}$		$V_{VS} + 0.3$	V	A
15.15	Input high leakage current I/O pin	PC0 to PC5 PB0 to PB7	14-19 22-29	I_{IH}			1	μA	A
15.20	Output low voltage	$I_{OL} = 0.2\text{mA}$	14-19 22-29	V_{OL_3V}			$0.1 \times V_{VS}$	V	A
15.30	Output high voltage	$I_{OH} = -0.2\text{mA}$	14-19 22-29	V_{OH_3V}	$0.9 \times V_{VS}$			V	A
15.40	I/O pin pull-up resistor	OFF mode: see port B and port C	14-19 22-29	R_{PU}	30	50	70	$\text{k}\Omega$	A
16.10	I/O pin output delay time (rising edge)	$C_{Load} = 10\text{pF}$	14-19 22-29	$T_{del_rise_3V}$	13.6	17.5	22.4	ns	D
16.20	I/O pin rise time ($0.1 \times V_{VS}$ to $0.9 \times V_{VS}$)	$C_{Load} = 10\text{pF}$	14-19 22-29	T_{rise_3V}	20.7	23.9	28.4	ns	D
16.30	I/O pin slew rate (rising edge)	$C_{Load} = 10\text{pF}$	14-19 22-29	$T_{sr_rise_3V}$	0.115	0.100	0.084	V/ns	D
16.40	I/O pin output delay time (falling edge)	$C_{Load} = 10\text{pF}$	14-19 22-29	$T_{del_fall_3V}$	13.7	17.4	22.7	ns	D
16.50	I/O pin fall time ($0.9 \times V_{VS}$ to $0.1 \times V_{VS}$)	$C_{Load} = 10\text{pF}$	14-19 22-29	T_{fall_3V}	16.2	19.2	22.5	ns	D
16.60	I/O pin slew rate (falling edge)	$C_{Load} = 10\text{pF}$	14-19 22-29	$T_{sr_fall_3V}$	0.148	0.125	0.106	V/ns	D

*) Type means: A = 100% tested at voltage and temperature limits, B = 100% correlation tested, C = characterized on samples, D = design parameter

3.8 Hardware Timings

All parameters refer to GND (backplane) and are valid for $T_{amb} = -40^{\circ}\text{C}$ to $+85^{\circ}\text{C}$, $V_{VS} = 1.9\text{V}$ to 3.6V over all process tolerances. Typical values are given at $V_{VS} = 3\text{V}$, $T_{amb} = 25^{\circ}\text{C}$, and for a typical process unless otherwise specified. Crystal oscillator frequency $f_{XTO} = 24.305\text{MHz}$.

No.	Parameters	Test Conditions	Pin	Symbol	Min.	Typ.	Max.	Unit	Type*
17.50	Startup time	PWRON = '1' or NPWRON = '0' to EVENT generation	13, 20	$T_{STARTUP}$		10		ms	C

*) Type means: A = 100% tested at voltage and temperature limits, B = 100% correlation tested, C = characterized on samples, D = design parameter

3.9 Hardware SPI Timing Characteristics

Timing shown for CPHA=0 and CPOL=0 in Figure 3-2, timing is valid for all CPHA and CPOL configurations. See also Section 2.1 “SPI Command Interface” on page 7 for functional SPI description and for firmware limitations on SPI data transfer.

All parameters refer to GND (backplane) and are valid for $T_{amb} = -40^{\circ}\text{C}$ to $+85^{\circ}\text{C}$, $V_{VS} = 1.9\text{V}$ to 3.6V (3V Application) and 4.5V to 5.5V (5V Application) over all process tolerances. Typical values are given at $V_{VS} = 5\text{V}$, $T_{amb} = 25^{\circ}\text{C}$, and for a typical process unless otherwise specified. Crystal oscillator frequency $f_{XTO} = 24.305\text{MHz}$.

No.	Parameters	Test Conditions	Pin	Symbol	Min.	Typ.	Max.	Unit	Type*
49.10	SCK cycle time		23	$T_{SCK_periode}$	8			μs	D
49.20	SCK high or low time		23	$T_{SCK_high_low}$	330			ns	D
49.30	SCK rise or fall time		23	$T_{SCK_rise_fall}$			100	ns	D
49.40	MOSI setup time to active edge of SCK		23, 24	T_{Setup}	80			ns	D
49.50	MOSI hold time to active edge of SCK		23, 24	T_{Hold}	245			ns	D
49.60	Time periode active edge of SCK to data out at MISO	$C_{LOAD_MISO} = 10\text{pF}$	23, 25	T_{SCK_out}			250	ns	D
49.70	Time periode SCK inactive to NSS high		23, 27	$T_{SCK_NSS_high}$	100			μs	D
49.80	Time periode NSS high to MISO tristate	$C_{LOAD_MISO} = 10\text{pF}$	25, 27	$T_{NSS_high_tristate}$			250	ns	D
49.90	Time periode NSS low to active edge SCK		23, 27	$T_{NSS_low_SCK}$	65			μs	D

*) Type means: A = 100% tested at voltage and temperature limits, B = 100% correlation tested, C = characterized on samples, D = design parameter

Figure 3-2. SPI Interface Timing Requirements

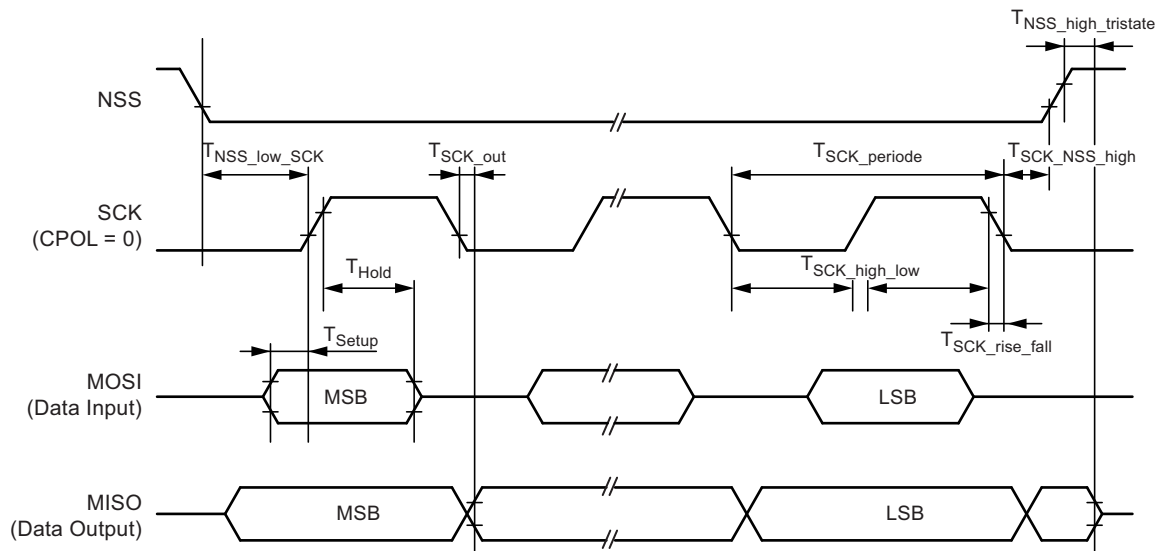

4. Ordering Information

Extended Type Number	Package	Remarks
ATA8520-GHQW	QFN32	5mm × 5mm, Pb-free, 6k, taped and reeled

5. Package Information

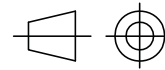
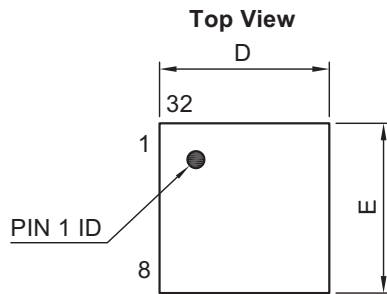

technical drawings
according to DIN
specifications

Dimensions in mm

Two Step Singulation process

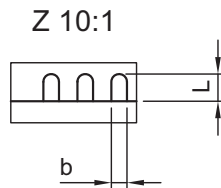
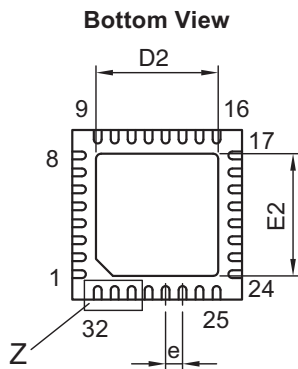
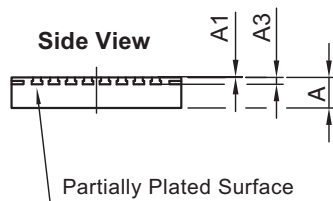

COMMON DIMENSIONS				
(Unit of Measure = mm)				
SYMBOL	MIN	NOM	MAX	NOTE
A	0.8	0.85	0.9	
A1	0	0.035	0.05	
A3	0.16	0.21	0.26	
D	4.9	5	5.1	
D2	3.5	3.6	3.7	
E	4.9	5	5.1	
E2	3.5	3.6	3.7	
L	0.35	0.4	0.45	
b	0.2	0.25	0.3	
e		0.5		

10/18/13

Atmel Package Drawing Contact:
packagedrawings@atmel.com

TITLE
Package: VQFN_5x5_32L
Exposed pad 3.6x3.6

GPC

DRAWING NO.
6.543-5124.03-4

REV.
1

6. Disclaimer

Atmel® components and materials in the Product comply with Atmel data sheet and the Product has achieved SIGFOX-compliant certification. Apart from these warranties, the customer acknowledges that no express or implied warranties are given in relation to the Product and, in particular, no warranties are given in relation to the quality or suitability of any third party software or materials incorporated into the Product.

Atmel does not warrant that the Product will be error-free and the Customer acknowledges that it has not been developed to meet the Customer's individual requirements. Accordingly, Atmel accepts no liability or responsibility with regard to any third party software or materials incorporated into the Product and in no event shall Atmel be liable for any direct, indirect or consequential loss (of whatever nature) caused by the use or possession of any third party software or material.

Without prejudice to the remainder of this Agreement, in no circumstances will Atmel's liability to the Customer for any direct loss or damage arising out of use or possession of the Product (if any) exceed the price payable for the relevant Order relating to the defective Product. In no circumstances will Atmel be liable for any indirect or consequential loss or for any loss of profits or revenue caused by the Product being defective.

7. Revision History

Please note that the following page numbers referred to in this section refer to the specific revision mentioned, not to this document.

Revision No.	History
9372H-INDCO-11/15	<ul style="list-style-type: none">• Section 2.2.1 “System Configuration” on page 13 updated
9372G-INDCO-10/15	<ul style="list-style-type: none">• Table 1-1 “Pin Description” on page 3 updated• Section 1.4 “Applications” on pages 5 to 6 updated
9372F-INDCO-09/15	<ul style="list-style-type: none">• Section 1.4.3 “Recommended PCB Design and Layout” removed• Section 3.5 “RF Transmit Characteristics” on page 17 updated
9372E-INDCO-08/15	<ul style="list-style-type: none">• Section 1.4.3 “Recommended PCB Design and Layout” on page 7 updated• Section 2.1 “SPI Command Interface” on pages 8 to 12 updated• Section 2.2 “Operating Modes Overview” on page 14 updated• Section 3.9 “Hardware SPI Timing Characteristics” on page 21 added
9372D-INDCO-06/15	<ul style="list-style-type: none">• Section 2.1 “SPI Command Interface” on pages 9 to 13 updated• Figure 3-1 “Atmel ESD Protection Circuit” on page 15 updated• Section 3.2 “Absolute Maximum Ratings” on page 16 updated• Section 3.4 “Supply Voltages and Current Consumption” on pages 16 to 17 updated• Section 6 “Disclaimer” on page 21 added
9372C-INDCO-06/15	<ul style="list-style-type: none">• Features on page 1 updated• Section 1.3 “Pinning” on page 3 updated• Section 1.4 “Applications and Recommendations” on pages 5 to 7 updated• Section 2 “System Functional Description” on pages 8 to 12 updated• Section 3.2 “Absolute Maximum Ratings” on page 15 updated• Section 3.4 “Supply Voltages and Current Consumption” on pages 15 to 16 updated• Section 3.5 “RF Transmit Characteristics” on page 16 updated• Section 3.8 “Hardware Timings” on page 18 updated
9372B-INDCO-01/15	<ul style="list-style-type: none">• Power-up timing in section “Features” on page 1 updated• Section 2.1.2.6 “Atmel Version” on page 7 updated• Table 2-1 “Command Table Overview” on page 9 updated• Section 2.2.1 “Power-up Sequence” on page 10 updated• Figure 2-2 “Power-up Sequence” on page 10 updated• Section 2.2.2 “Application Example” on page 10 updated



Atmel Corporation 1600 Technology Drive, San Jose, CA 95110 USA T: (+1)(408) 441.0311 F: (+1)(408) 436.4200 | www.atmel.com

© 2015 Atmel Corporation. / Rev.: 9372H-INDCO-11/15

Atmel®, Atmel logo and combinations thereof, Enabling Unlimited Possibilities®, AVR®, and others are registered trademarks or trademarks of Atmel Corporation in U.S. and other countries. Other terms and product names may be trademarks of others.

DISCLAIMER: The information in this document is provided in connection with Atmel products. No license, express or implied, by estoppel or otherwise, to any intellectual property right is granted by this document or in connection with the sale of Atmel products. EXCEPT AS SET FORTH IN THE ATMEL TERMS AND CONDITIONS OF SALES LOCATED ON THE ATMEL WEBSITE, ATMEL ASSUMES NO LIABILITY WHATSOEVER AND DISCLAIMS ANY EXPRESS, IMPLIED OR STATUTORY WARRANTY RELATING TO ITS PRODUCTS INCLUDING, BUT NOT LIMITED TO, THE IMPLIED WARRANTY OF MERCHANTABILITY, FITNESS FOR A PARTICULAR PURPOSE, OR NON-INFRINGEMENT. IN NO EVENT SHALL ATMEL BE LIABLE FOR ANY DIRECT, INDIRECT, CONSEQUENTIAL, PUNITIVE, SPECIAL OR INCIDENTAL DAMAGES (INCLUDING, WITHOUT LIMITATION, DAMAGES FOR LOSS AND PROFITS, BUSINESS INTERRUPTION, OR LOSS OF INFORMATION) ARISING OUT OF THE USE OR INABILITY TO USE THIS DOCUMENT, EVEN IF ATMEL HAS BEEN ADVISED OF THE POSSIBILITY OF SUCH DAMAGES. Atmel makes no representations or warranties with respect to the accuracy or completeness of the contents of this document and reserves the right to make changes to specifications and products descriptions at any time without notice. Atmel does not make any commitment to update the information contained herein. Unless specifically provided otherwise, Atmel products are not suitable for, and shall not be used in, automotive applications. Atmel products are not intended, authorized, or warranted for use as components in applications intended to support or sustain life.

SAFETY-CRITICAL, MILITARY, AND AUTOMOTIVE APPLICATIONS DISCLAIMER: Atmel products are not designed for and will not be used in connection with any applications where the failure of such products would reasonably be expected to result in significant personal injury or death ("Safety-Critical Applications") without an Atmel officer's specific written consent. Safety-Critical Applications include, without limitation, life support devices and systems, equipment or systems for the operation of nuclear facilities and weapons systems. Atmel products are not designed nor intended for use in military or aerospace applications or environments unless specifically designated by Atmel as military-grade. Atmel products are not designed nor intended for use in automotive applications unless specifically designated by Atmel as automotive-grade.

Mouser Electronics

Authorized Distributor

Click to View Pricing, Inventory, Delivery & Lifecycle Information:

[Microchip:](#)

[ATA8520-GHQW](#)



Компания «ЭлектроПласт» предлагает заключение долгосрочных отношений при поставках импортных электронных компонентов на взаимовыгодных условиях!

Наши преимущества:

- Оперативные поставки широкого спектра электронных компонентов отечественного и импортного производства напрямую от производителей и с крупнейших мировых складов;
- Поставка более 17-ти миллионов наименований электронных компонентов;
- Поставка сложных, дефицитных, либо снятых с производства позиций;
- Оперативные сроки поставки под заказ (от 5 рабочих дней);
- Экспресс доставка в любую точку России;
- Техническая поддержка проекта, помощь в подборе аналогов, поставка прототипов;
- Система менеджмента качества сертифицирована по Международному стандарту ISO 9001;
- Лицензия ФСБ на осуществление работ с использованием сведений, составляющих государственную тайну;
- Поставка специализированных компонентов (Xilinx, Altera, Analog Devices, Intersil, Interpoint, Microsemi, Aeroflex, Peregrine, Syfer, Eurofarad, Texas Instrument, Miteq, Cobham, E2V, MA-COM, Hittite, Mini-Circuits, General Dynamics и др.);

Помимо этого, одним из направлений компании «ЭлектроПласт» является направление «Источники питания». Мы предлагаем Вам помощь Конструкторского отдела:

- Подбор оптимального решения, техническое обоснование при выборе компонента;
- Подбор аналогов;
- Консультации по применению компонента;
- Поставка образцов и прототипов;
- Техническая поддержка проекта;
- Защита от снятия компонента с производства.



Как с нами связаться

Телефон: 8 (812) 309 58 32 (многоканальный)

Факс: 8 (812) 320-02-42

Электронная почта: org@eplast1.ru

Адрес: 198099, г. Санкт-Петербург, ул. Калинина, дом 2, корпус 4, литера А.