

Amphenol
FCi

© 2016 AFCI

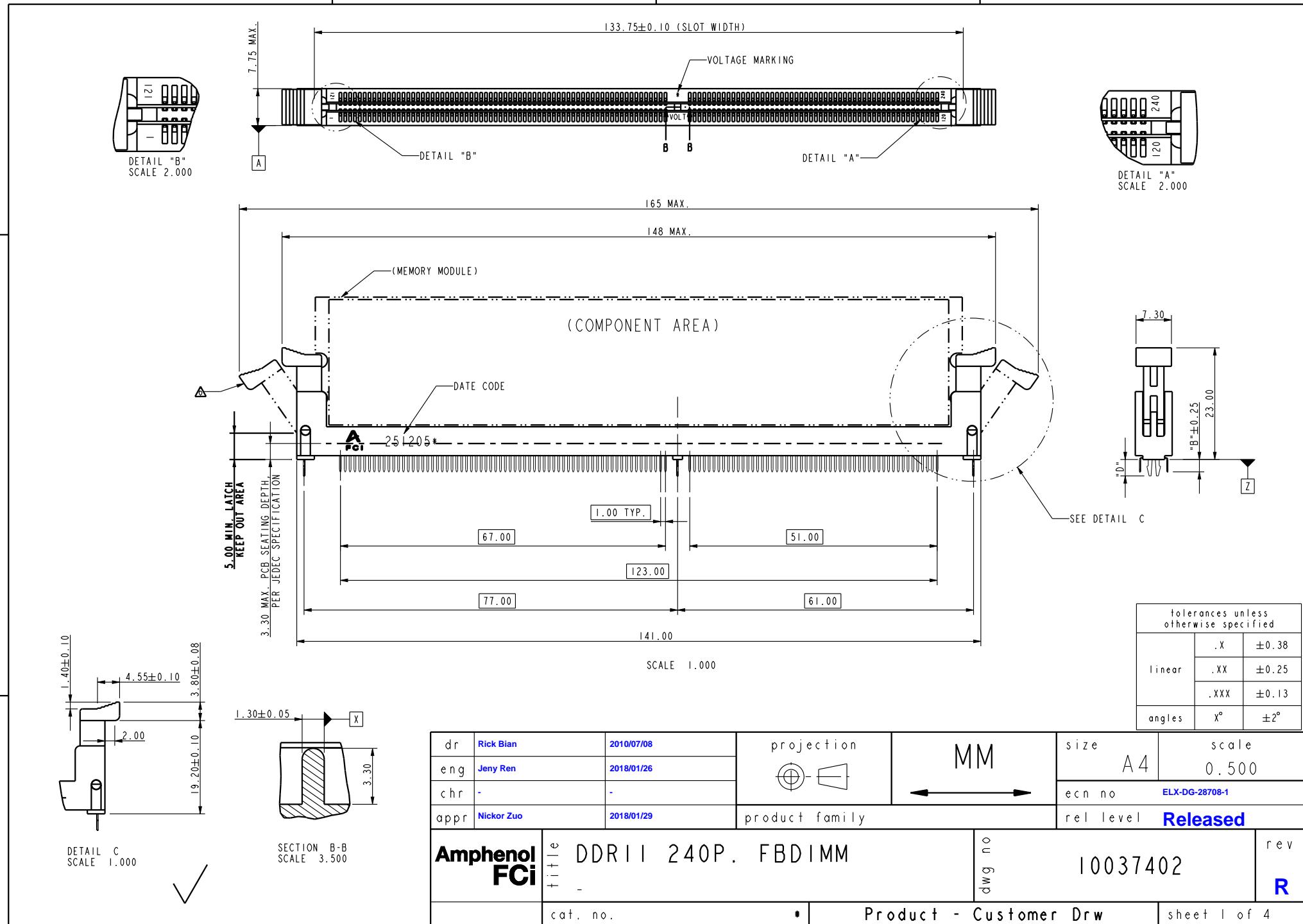

Creo File - REV E - 2016-02-12

PDS: Rev :R

STATUS:Released

Printed: Feb 06, 2018



SCALE 1.000
RECOMMENDED MODULE LAYOUT (PER JEDEC MO-256)

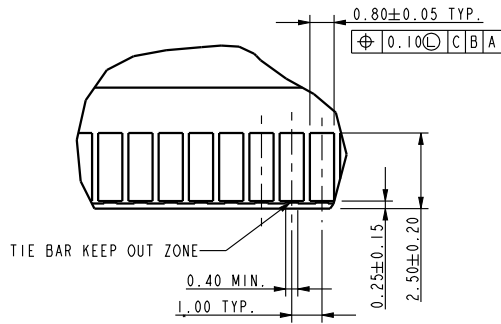

DETAIL E
SCALE 4.000

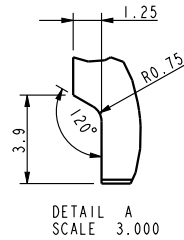

DETAIL A
SCALE 3.000

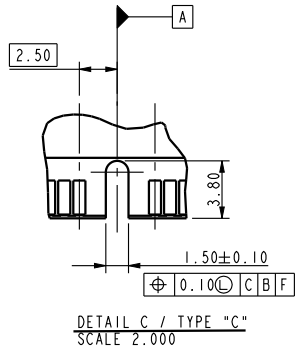

DETAIL C / TYPE "C"
SCALE 2.000

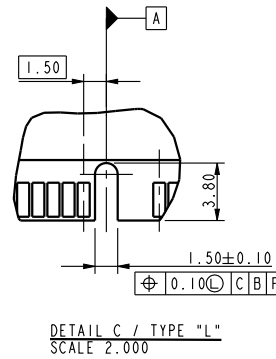

DETAIL C / TYPE "L"
SCALE 2.000

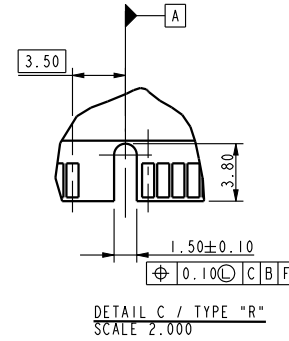

DETAIL C / TYPE "R"
SCALE 2.000

tolerances unless otherwise specified		
linear	.X	±0.38
	.XX	±0.15
	.XXX	±0.13
angles	x°	±2°

dr	Rick Bian	2010/07/08	projection	MM	size	A4	scale	0.500		
eng	Jeny Ren	2018/01/26			ecn no	ELX-DG-28708-1				
chr	-	-				rel level	Released			
appr	Nickor Zuo	2018/01/29	product family			rel level	Released			
Amphenol FCI		title			DDR11 240P. FBDIMM		dwg no		10037402	
cat. no.		*			Product - Customer Drw		sheet 2 of 4		rev	R



DETAIL D
SCALE 4.000

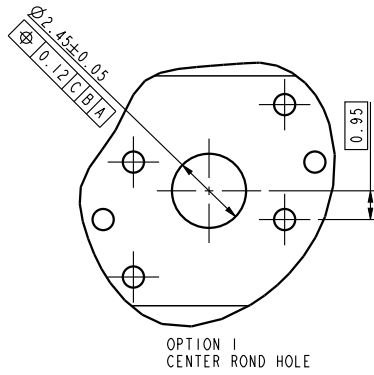
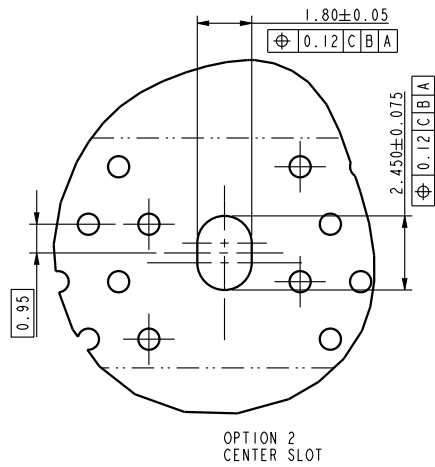

TYPE R	X.X VOLTAGE	6.80	1.40	2.80	8.20	6.80	3.00	4.40	9.80
TYPE L	2.5 VOLTAGE	6.80	1.40	2.80	8.20	6.80	3.00	4.40	9.80
TYPE C	1.8 VOLTAGE	6.80	1.40	2.80	8.20	6.80	3.00	4.40	9.80
SUB KEY POS. #1	DESCRIPTION	TYPE 1				TYPE 2			
		DIM. E1 MAX.	DIM. E2 MAX.	DIM. E3 MAX.	DIM. E MAX.	DIM. E1 MAX.	DIM. E2 MAX.	DIM. E3 MAX.	DIM. E MAX.

dr	Rick Bian	2010/07/08	projection 	MM 	size	A4	scale	0.500
eng	Jeny Ren	2018/01/26			ecn no	ELX-DG-28708-1		
chr	-	-			rel level	Released		
appr	Nickor Zuo	2018/01/29	product family			rev	R	
Amphenol FCI		title		DDR11 240P. FBDIMM		dwg no		10037402
cat. no.		*		Product - Customer Drw		sheet		3 of 4

10037402-□ □ □ □ □

STYLE : MECHANICAL KEYING

- 1 : 1.8 VOLT. W/TYPE "C"
- 2 : 2.5 VOLT. W/TYPE "L"
- 3 : X.X VOLT. W/TYPE "R"

**METAL CLIP
(WITH NI 1.27 um MIN. PLATING)**

- 1 : WITH METAL CLIP + DIM."D"=3.05
- 2 : WITH METAL CLIP + DIM."D"=3.56
- 3 : WITH METAL CLIP + DIM."D"=3.43

TAIL LENGTH

CODE	DIM. "B"	PCB THICKNESS
0	2.54	1.47 mm (0.058")
1	2.67	1.60 mm (0.063")
2	3.18	2.36 mm (0.093")
3	4.00	3.18 mm (0.125")

PLATING

CODE	CONTACT	SOLDERTAIL	UNDERPLATE
2	15 u"(0.38um) MIN. GOLD	100u"(2.54um) MIN. TIN/LEAD	50u"(1.27um) MIN. NICKEL OVERALL
3	30u"(0.76um) MIN. GOLD		
4	3u"(0.076um) MIN. GOLD	100u"(2.54um) MIN. 100% TIN	50u"(1.27um) MIN. NICKEL OVERALL
7LF	15u"(0.38um) MIN. GOLD		
8LF	30u"(0.76um) MIN. GOLD	100u"(2.54um) MIN. 100% TIN	90u"(2.29um) MIN. NICKEL OVERALL
9LF	3u"(0.076um) MIN. GOLD		
2N	15 u"(0.38um) MIN. GOLD	100u"(2.54um) MIN. TIN/LEAD	90u"(2.29um) MIN. NICKEL OVERALL
3N	30 u"(0.76um) MIN. GOLD		
4N	3 u"(0.076um) MIN. GOLD	100u"(2.54um) MIN. 100% TIN	90u"(2.29um) MIN. NICKEL OVERALL
7NLF	15 u"(0.38um) MIN. GOLD		
8NLF	30 u"(0.76um) MIN. GOLD	100u"(2.54um) MIN. 100% TIN	90u"(2.29um) MIN. NICKEL OVERALL
9NLF	3 u"(0.076um) MIN. GOLD		

COLOR OF HOUSING AND EJECTOR

- 0 : BLACK HOUSING + IVORY EJECTOR
- 1 : BLUE HOUSING + IVORY EJECTOR
- 2 : BLACK HOUSING + BLACK EJECTOR
- 3 : IVORY HOUSING + IVORY EJECTOR

NOTE:

1. MATERIAL:
HOUSING: HIGH PERFORMANCE RESINS, GLASS FILLED UL94V-0 RATED.
EJECTOR: HIGH PERFORMANCE RESINS, GLASS FILLED UL 94V-0 RATED.
TERMINAL : COPPER ALLOY.
METAL CLIP: COPPER ALLOY.
2. PRODUCT SPECIFICATION: GS-12-300.
DIMENSIONS APPLICABLE WHEN COMPONENTS MOUNTED ON ONE OR BOTH SIDES.
CARD THICKNESS APPLIES ACROSS TABS AND INCLUDES PLATING AND/OR
REALIZATION STRAIGHTNESS CALLOUT APPLIES TO ZONE DEFINED BY THE 4.00 CONTACT
AREA DIMENSION FOR THE ENTIRE LENGTH OF 133.35.
BOARD OF COMPONENT AREA.
3. LATCH DESIGN INCLUDES COMPLEMENTARY FEATURE TO ACCOMMODATE MODULE
END NOTCHES AS DEFINED IN DETAIL A OF P.2 AND AS SPECIFIED IN MO-256.
7. THIS PRODUCT MEETS EUROPEAN UNION DIRECTIVES AND OTHER COUNTRY REGULATIONS
AS DESCRIBED IN GS-22-008.
8. THE HOUSING WILL WITHSTAND EXPOSURE TO 260°C PEAK TEMP. FOR 10 SECONDS IN A WAVE
SOLDER APPLICATION
9. 10037402-XXXX(X)LF SERIES ARE FOR LEAD-FREE OPTIONS.
10. DATE CODE:XXXXXX* SHOWS DAY/MONTH/YEAR."*" MEANS PRODUCTION LINE CODE.



dr	Rick Bian	2010/07/08	projection 	MM 	size	A4	scale	0.500
eng	Jeny Ren	2018/01/26			ecn no	ELX-DG-28708-1		
chr	-	-			rel level	Released		
appr	Nickor Zuo	2018/01/29	product family		rev	R		
Amphenol FCi		DDR11 240P. FBDIMM			dwg no	10037402		
cat. no.		Product - Customer Drw			sheet 4 of 4			



Компания «ЭлектроПласт» предлагает заключение долгосрочных отношений при поставках импортных электронных компонентов на взаимовыгодных условиях!

Наши преимущества:

- Оперативные поставки широкого спектра электронных компонентов отечественного и импортного производства напрямую от производителей и с крупнейших мировых складов;
- Поставка более 17-ти миллионов наименований электронных компонентов;
- Поставка сложных, дефицитных, либо снятых с производства позиций;
- Оперативные сроки поставки под заказ (от 5 рабочих дней);
- Экспресс доставка в любую точку России;
- Техническая поддержка проекта, помощь в подборе аналогов, поставка прототипов;
- Система менеджмента качества сертифицирована по Международному стандарту ISO 9001;
- Лицензия ФСБ на осуществление работ с использованием сведений, составляющих государственную тайну;
- Поставка специализированных компонентов (Xilinx, Altera, Analog Devices, Intersil, Interpoint, Microsemi, Aeroflex, Peregrine, Syfer, Eurofarad, Texas Instrument, Miteq, Cobham, E2V, MA-COM, Hittite, Mini-Circuits, General Dynamics и др.);

Помимо этого, одним из направлений компании «ЭлектроПласт» является направление «Источники питания». Мы предлагаем Вам помощь Конструкторского отдела:

- Подбор оптимального решения, техническое обоснование при выборе компонента;
- Подбор аналогов;
- Консультации по применению компонента;
- Поставка образцов и прототипов;
- Техническая поддержка проекта;
- Защита от снятия компонента с производства.



Как с нами связаться

Телефон: 8 (812) 309 58 32 (многоканальный)

Факс: 8 (812) 320-02-42

Электронная почта: org@eplast1.ru

Адрес: 198099, г. Санкт-Петербург, ул. Калинина, дом 2, корпус 4, литера А.